

# Microwave Technic - Basic Training

## Advantages

---

- time-saving cooking speed
- the taste (natural flavor)
- healthy cooking, no fat used, no loss of vitamins
- energy saving, no pre-heating and speed
- quick and problem free defrosting
- less washing up, food cooked in the serving dish
- easy to clean
- easy to use

# Microwave Technic - Basic Training

## Basics general

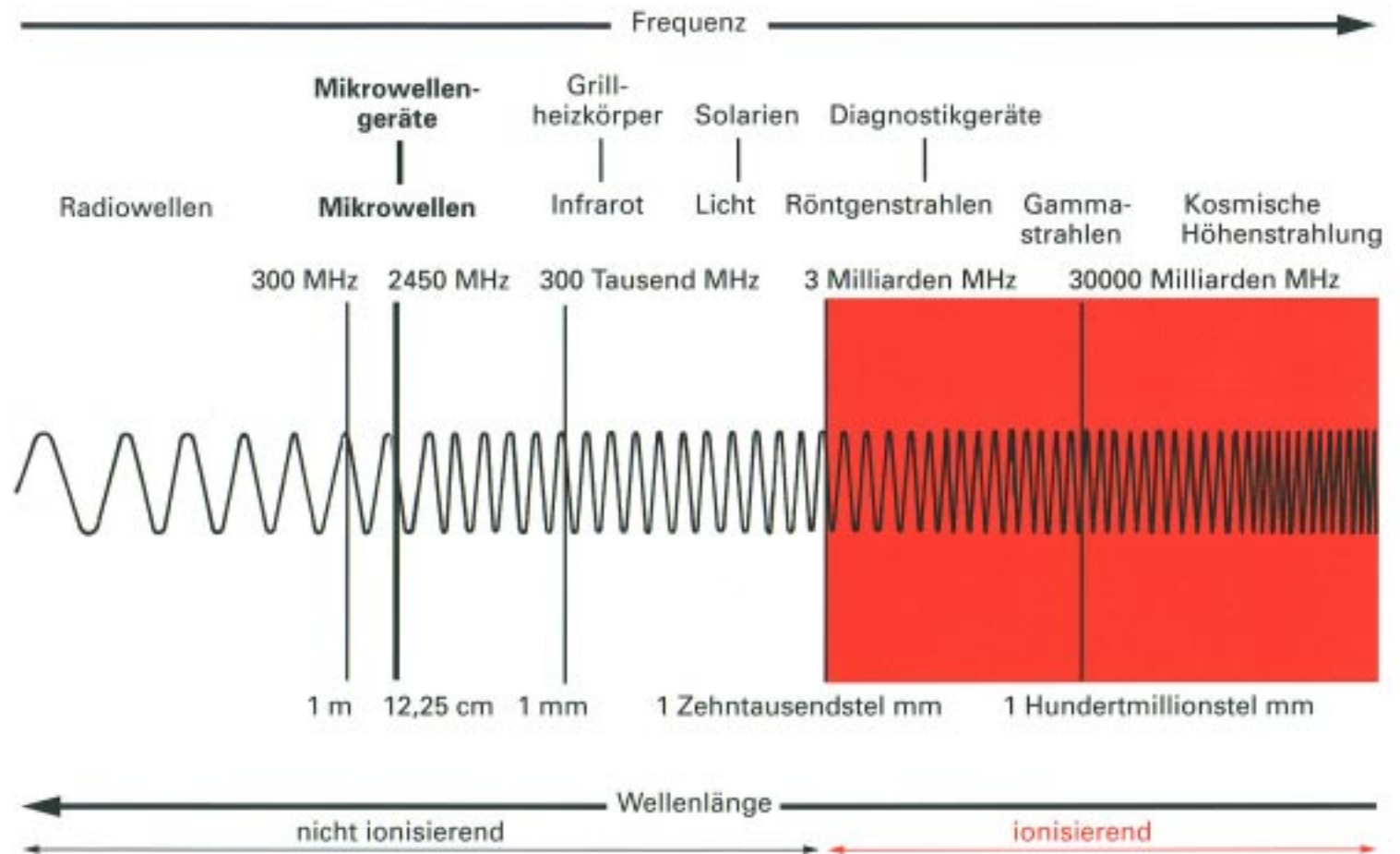

# Microwave Technic - Basic Training

## Basics general

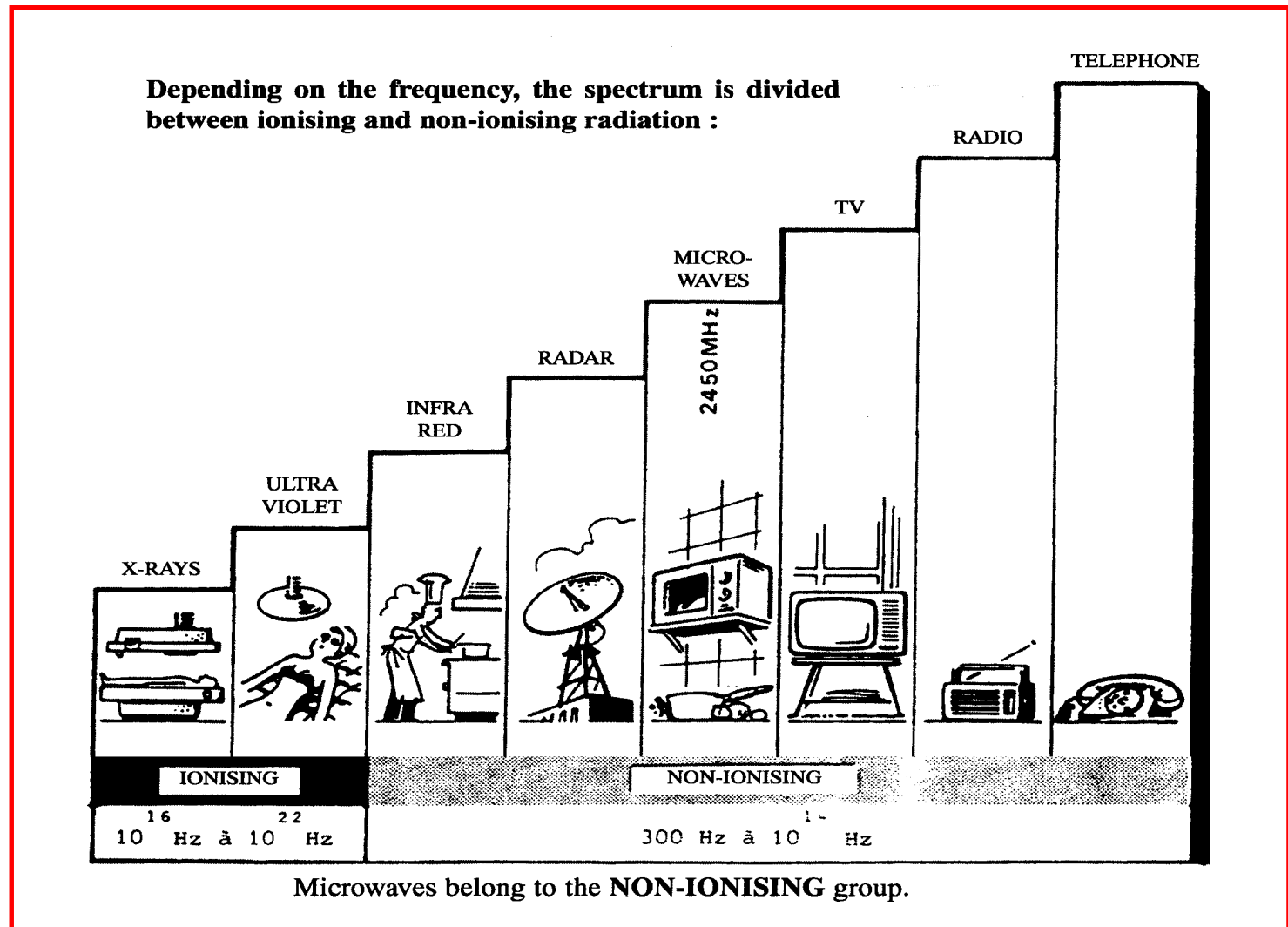

# Microwave Technic - Basic Training

## Basics general

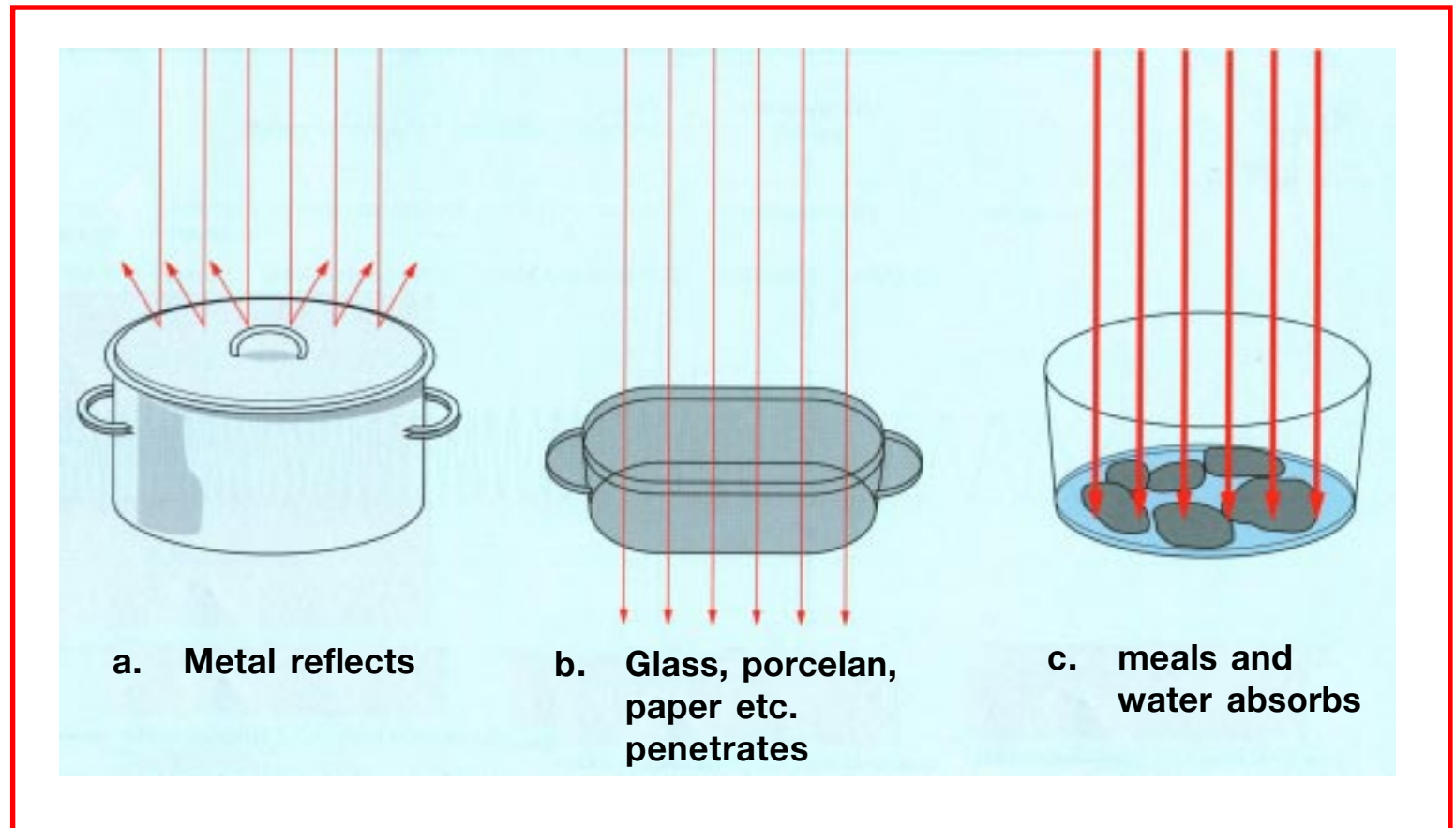

# Microwave Technic - Basic Training

## Basics general

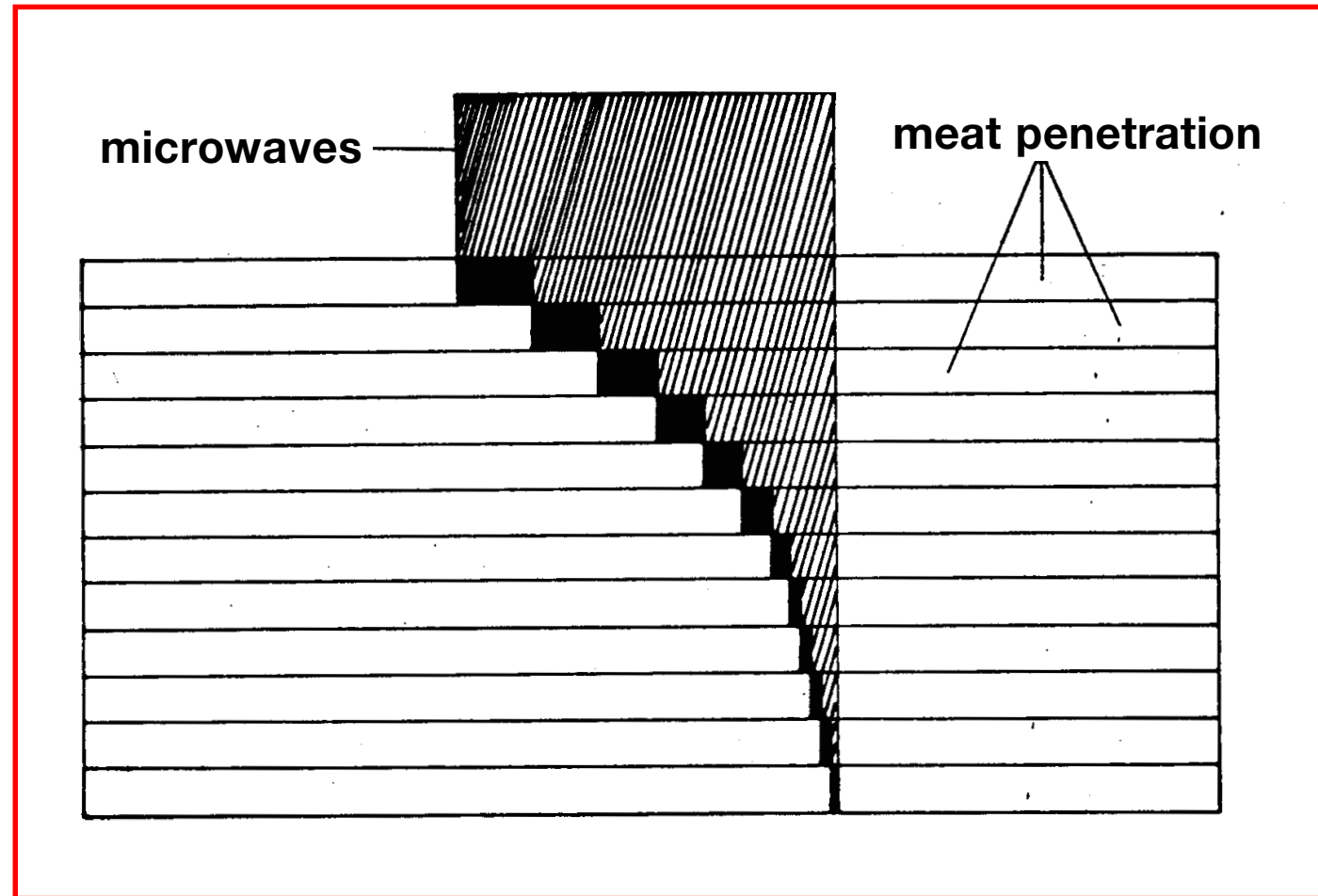

# Microwave Technic - Basic Training

## Basics general

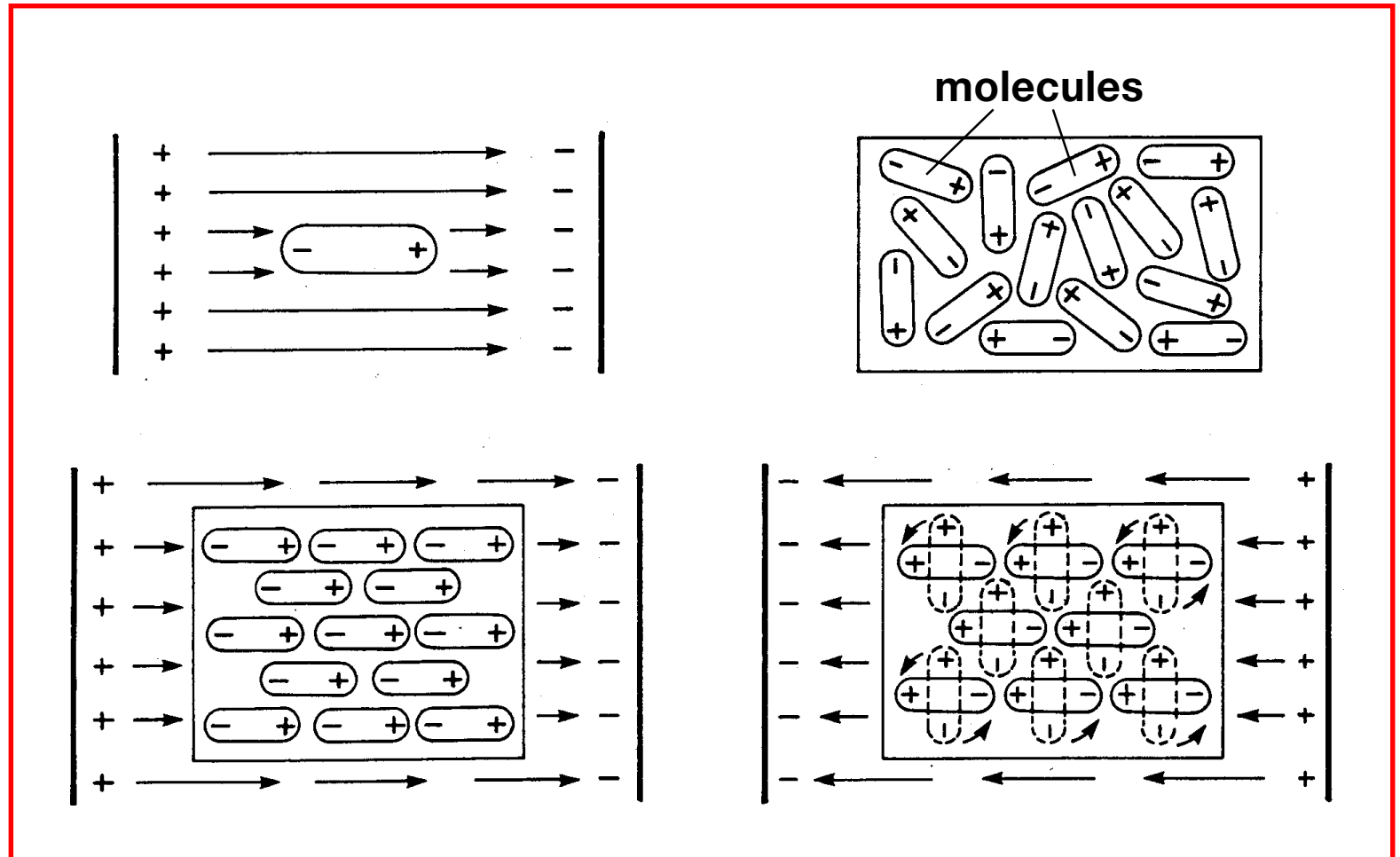

# Microwave Technic - Basic Training

## Basics general

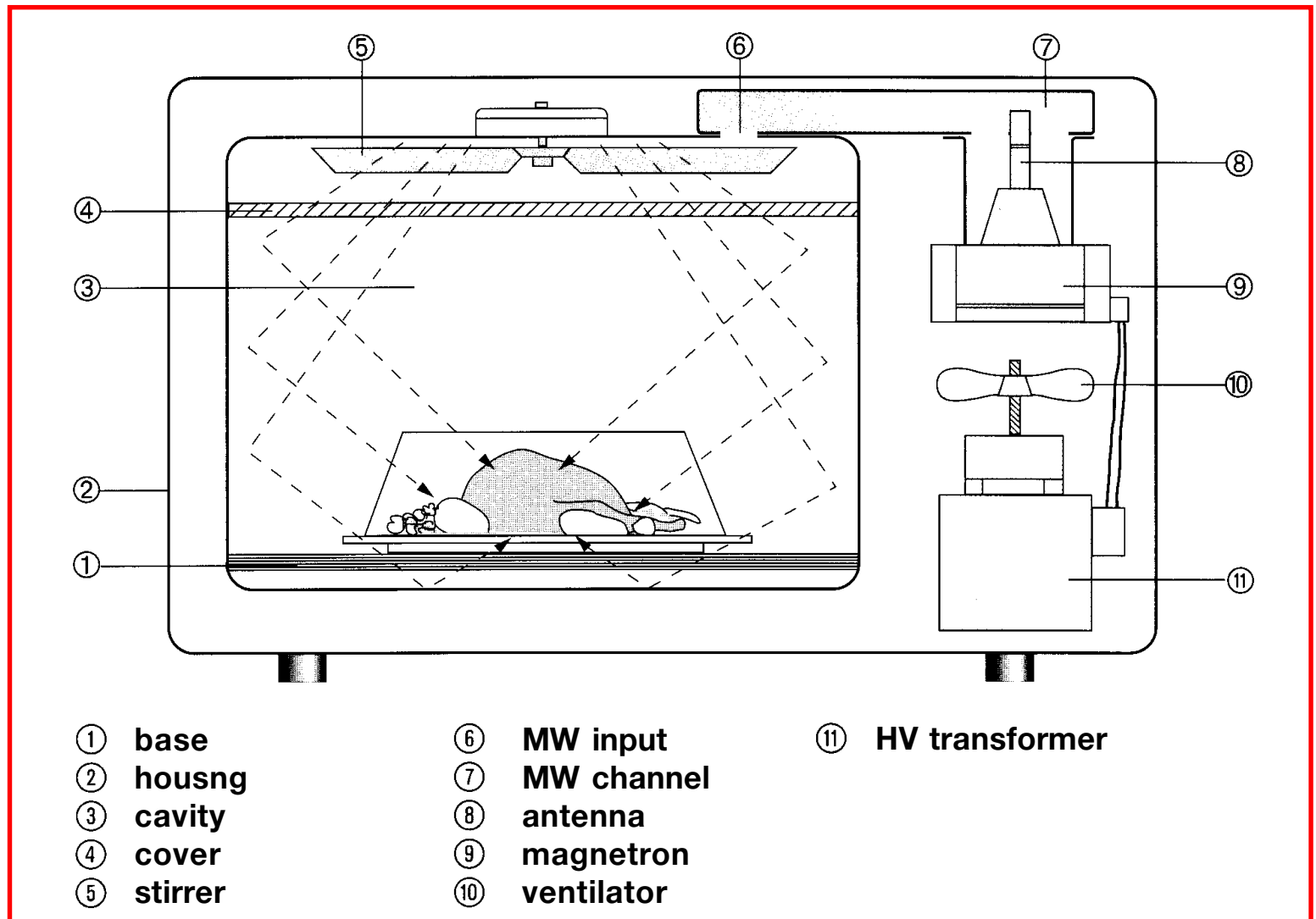





# Microwave Technic - Basic Training

## Basics general

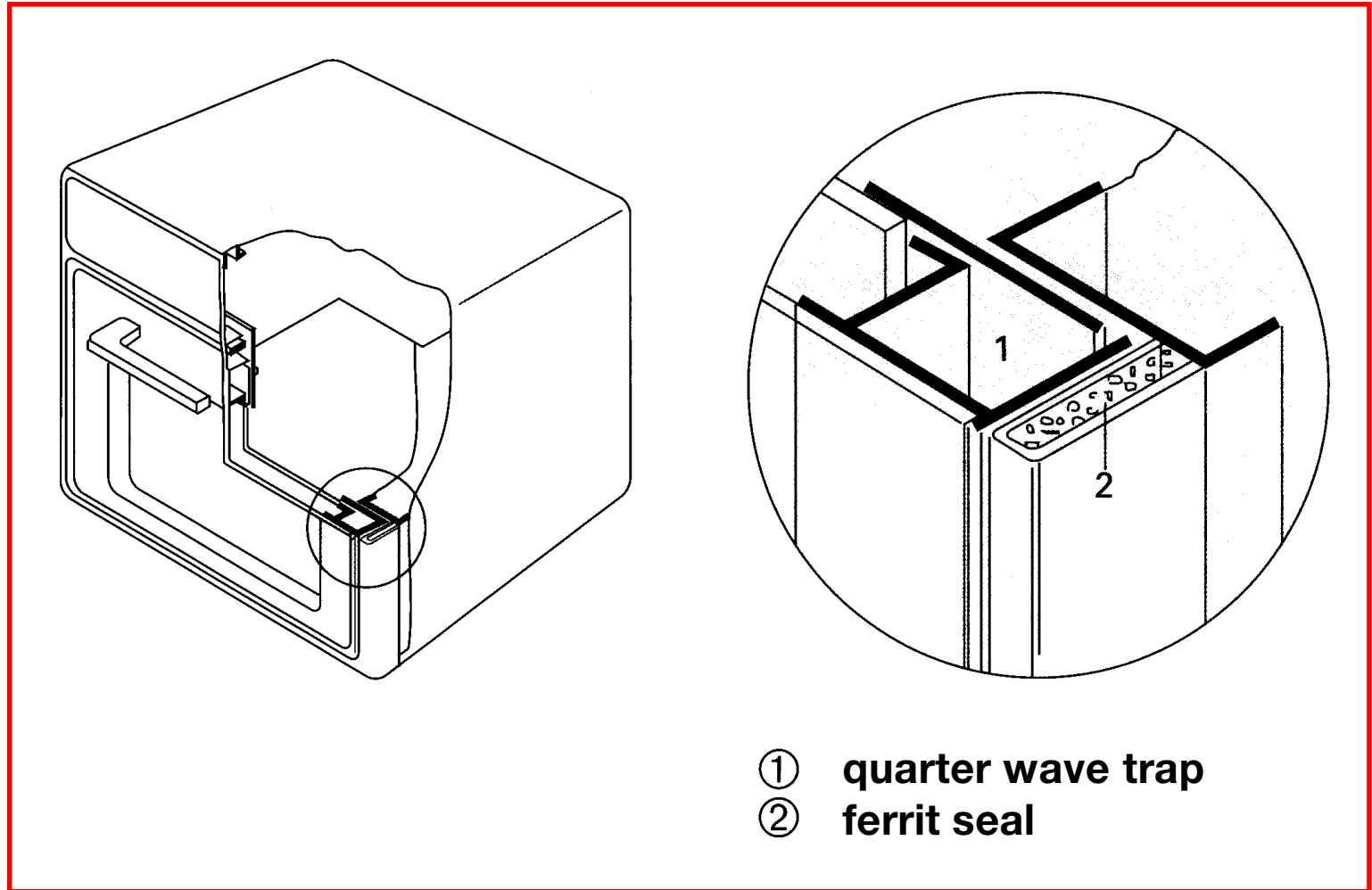

# Microwave Technic - Basic Training

## Basics general

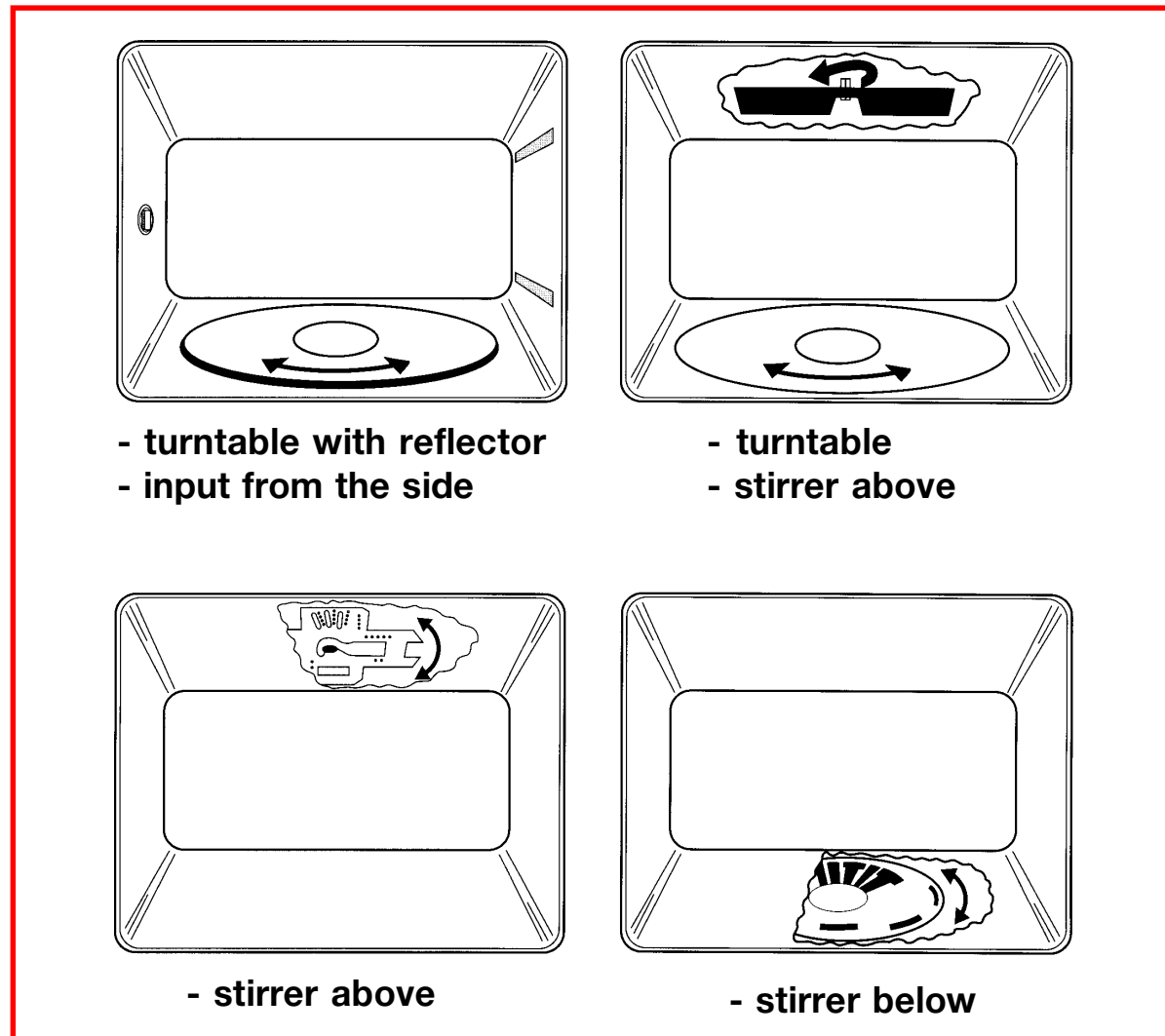

# Microwave Technic - Basic Training

## Basics general

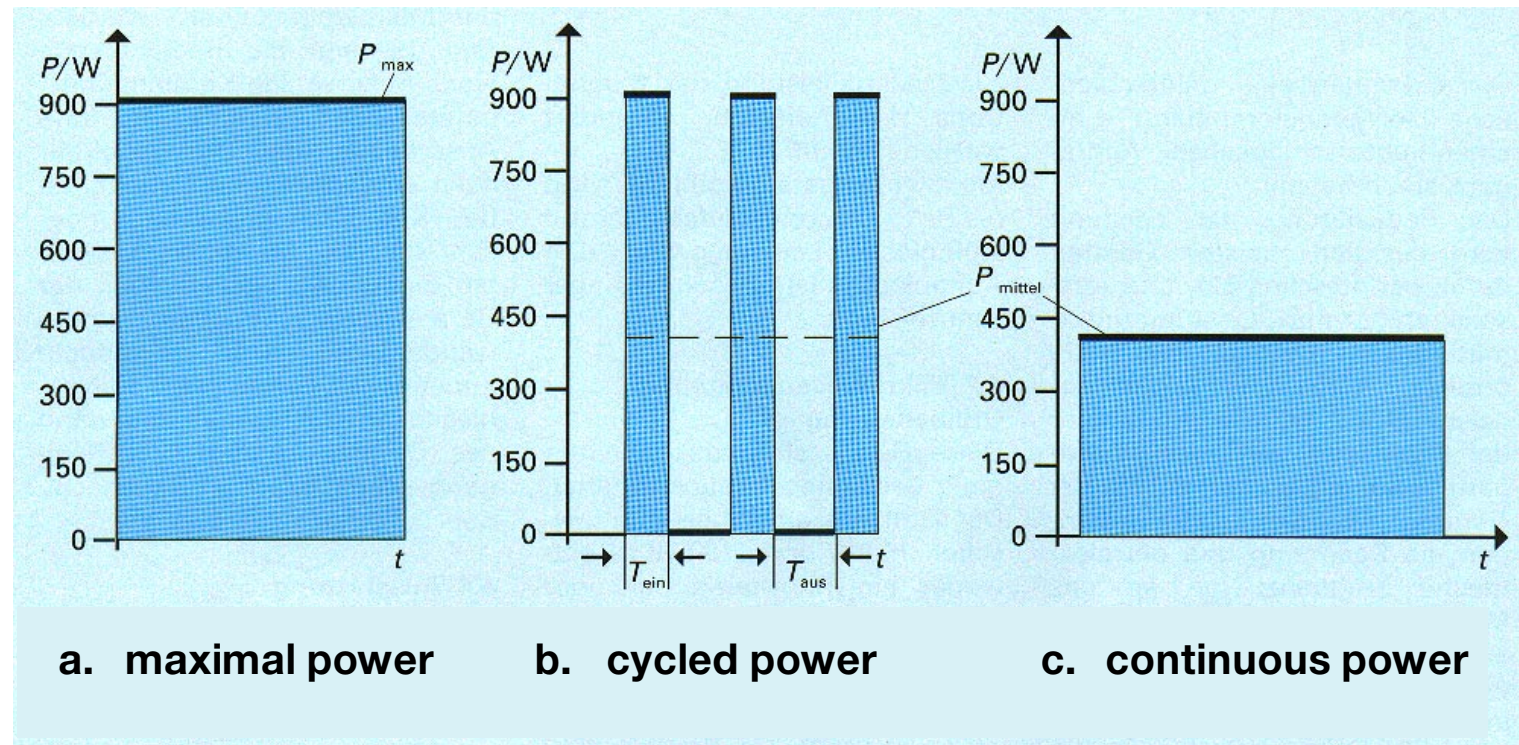

# Microwave Technic - Basic Training

## Basics general

POWER LEVEL	OUTPUT POWER AGAINST FULL POWER	RELAY "1" TURN ON, OFF TIME
0	0/29 (0%)	ON $\overbrace{\hspace{2cm}}^{29S}$ OFF
1	3/29 (10%)	ON $\overbrace{\hspace{0.5cm}}^{3S}$ OFF
2	5/29 (17%)	ON $\overbrace{\hspace{0.7cm}}^{5S}$ OFF
3	8/29 (28%)	ON $\overbrace{\hspace{0.9cm}}^{8S}$ OFF
4	11/29 (38%)	ON $\overbrace{\hspace{1.1cm}}^{11S}$ OFF
5	14/29 (48%)	ON $\overbrace{\hspace{1.3cm}}^{14S}$ OFF
6	17/29 (59%)	ON $\overbrace{\hspace{1.5cm}}^{17S}$ OFF
7	20/29 (69%)	ON $\overbrace{\hspace{1.7cm}}^{20S}$ OFF
8	23/29 (79%)	ON $\overbrace{\hspace{1.9cm}}^{23S}$ OFF
9	26/29 (90%)	ON $\overbrace{\hspace{2.1cm}}^{26S}$ OFF
HI	29/29 (100%)	ON $\overbrace{\hspace{2.3cm}}^{29S}$ OFF

# Microwave Technic - Basic Training

## Basics general

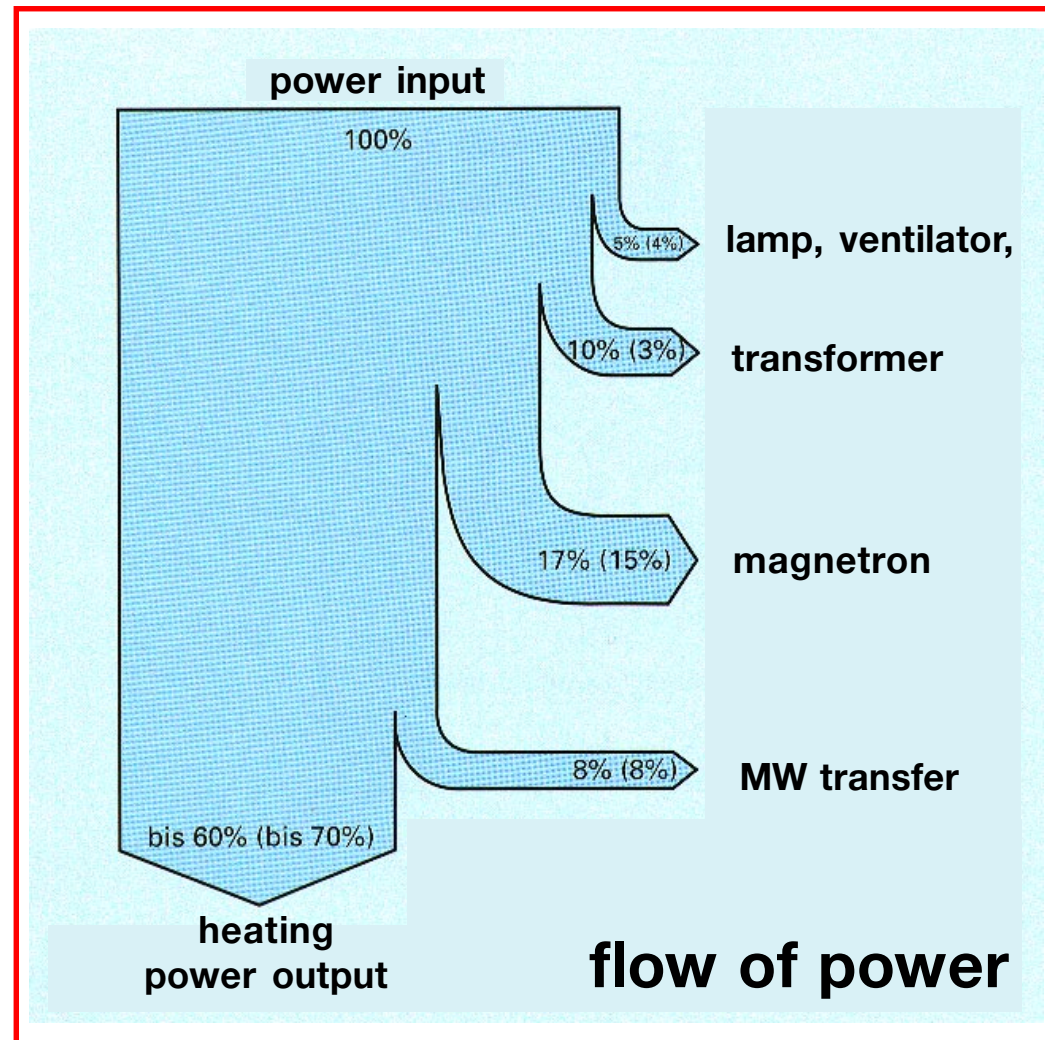

# Microwave Technic - Basic Training

## Basics general

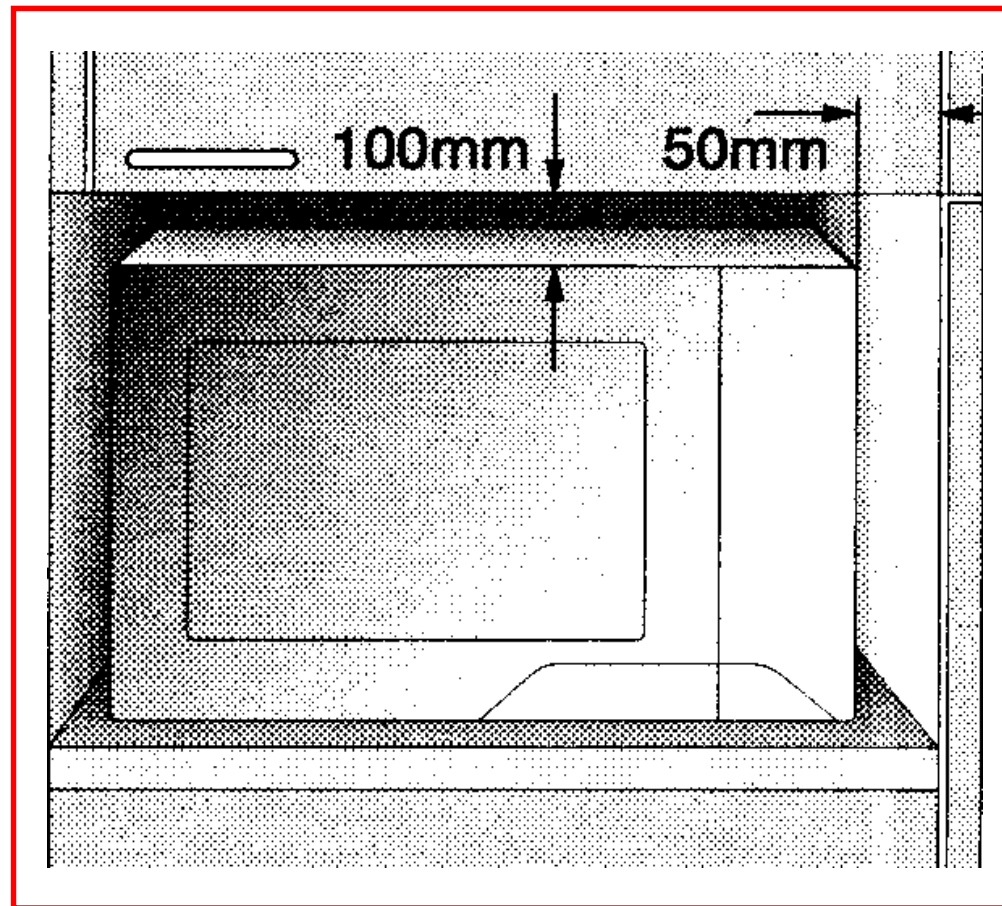

# Microwave Technic - Basic Training

## Basics general

The diagram illustrates three different microwave control panel designs, each with numbered callouts (1-11) identifying key components:

- Mechanic timer:** Features a power dial (1) with settings like 'Fortkochen', 'Erhitzen', 'Garen', 'Warmhalten', and 'Auftauen'; a time dial (2) with a scale from 0 to 30 minutes; and a door opener (3).
- „easy to use“ electronic:** Includes a digital display (1) showing '11:45'; a power dial (2) with settings for 80 W, 150 W, 300 W, 450 W, and 600 W; a time dial (3); and buttons for 'Stop/C' (4), 'START' (7), and a door opener (9).
- Electronic with grill:** Features a digital display (1) showing '1 150 G'; a clock (2); buttons for 'AUTO' (4), 'Auftauen' (5), 'Crisp' (6), 'Timer' (3), 'Mikro' (7), 'Grill' (8), and 'Crisp' (9); and buttons for 'Schnell' (11), 'Start' (10), and 'Stop' (10).

**mechanic timer**

- power
- timer
- door opener

**„easy to use“ electronic**

- display
- power
- timer
- start knob
- features + features
- door opener

**electronic with grill**

- display
- clock
- 3-5. features
- power
- timer
7. timer
- 8+9. features
10. stop
11. start

# Microwave Technic - Basic Training

## Basics general



**= 4 min.**



**= 8 min.**



# Microwave Technic - Basic Training

## Basics general

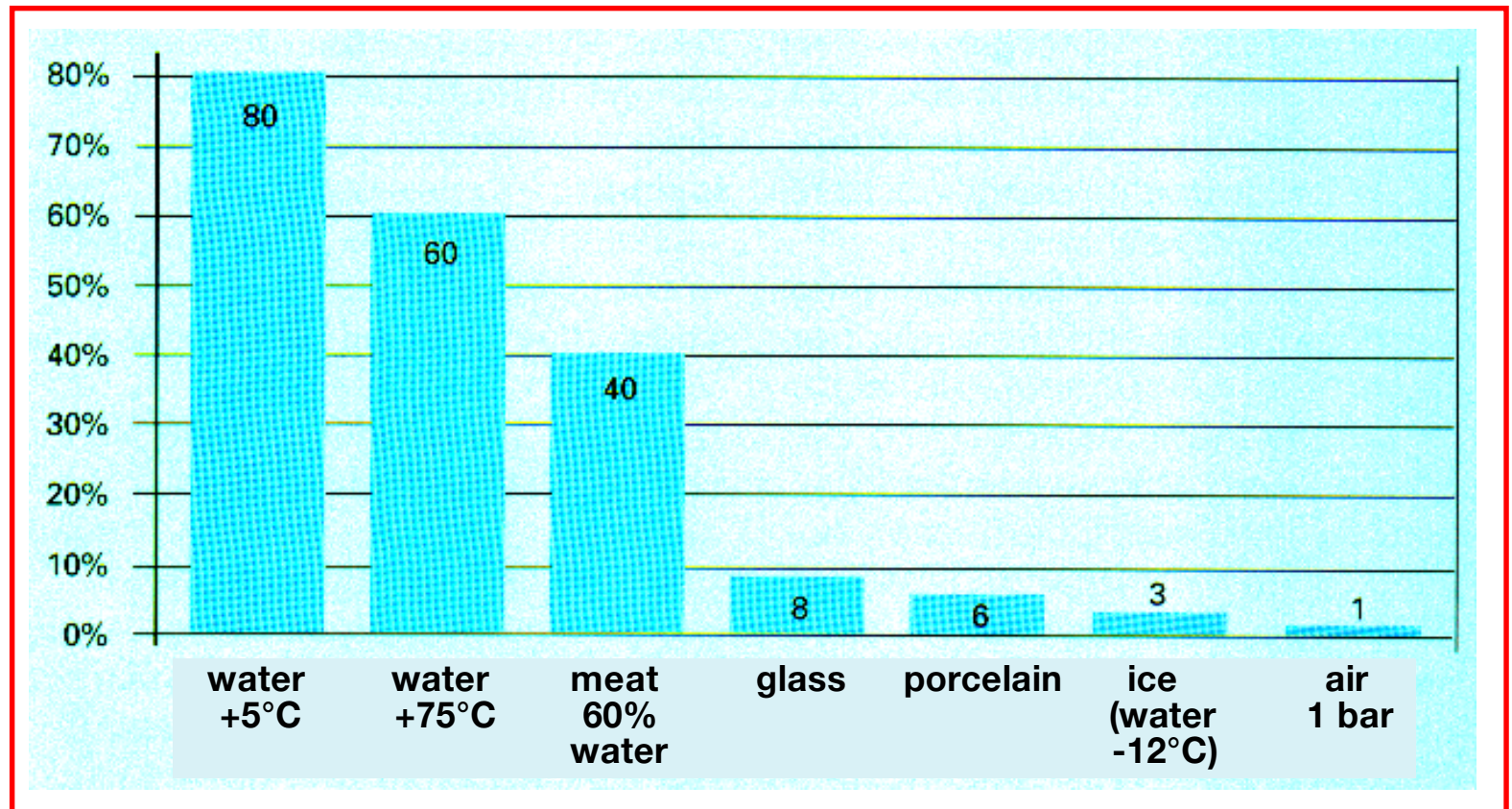

# Microwave Technic - Basic Training

## Basics general

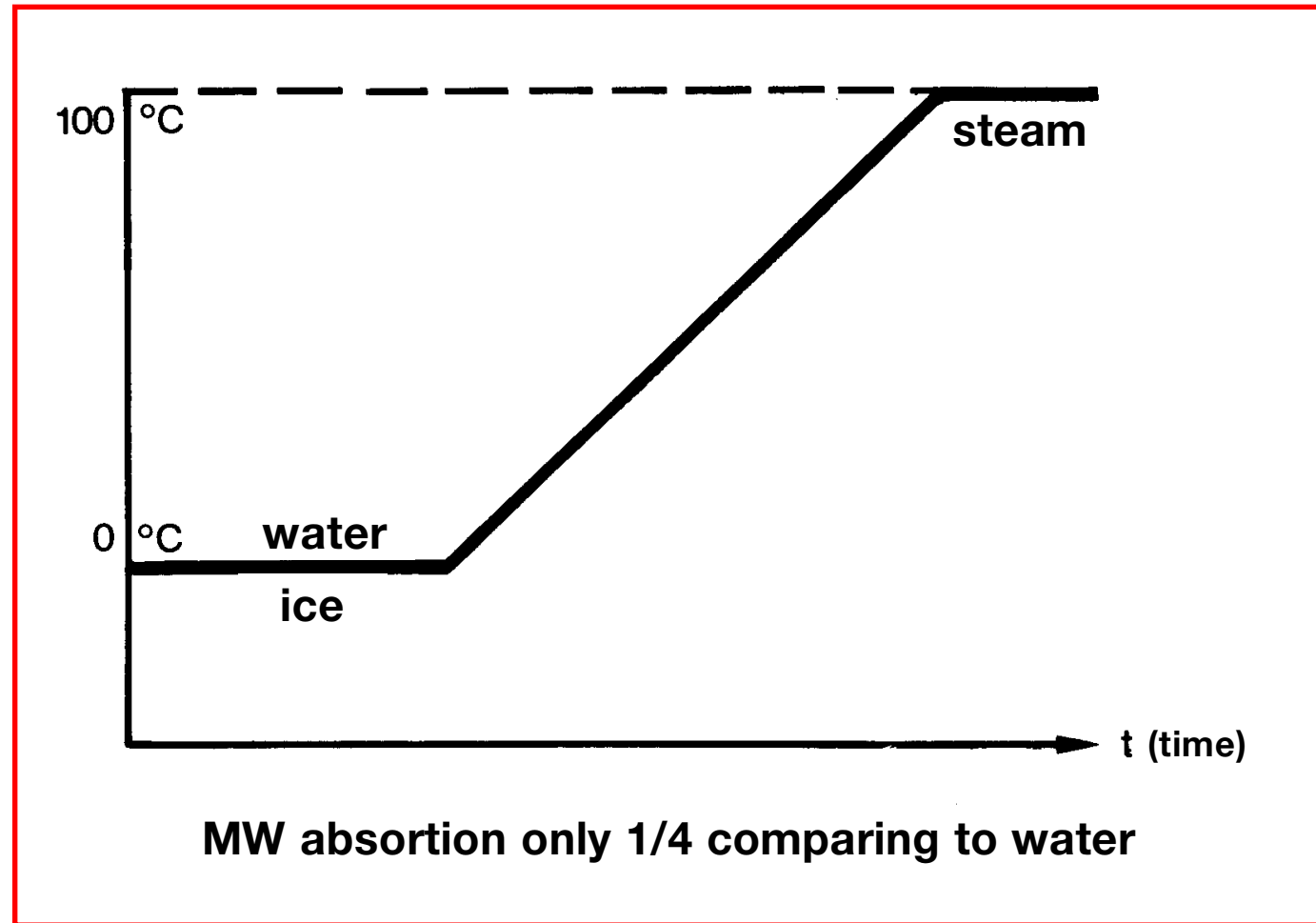

# Microwave Technic - Basic Training

## Basics general

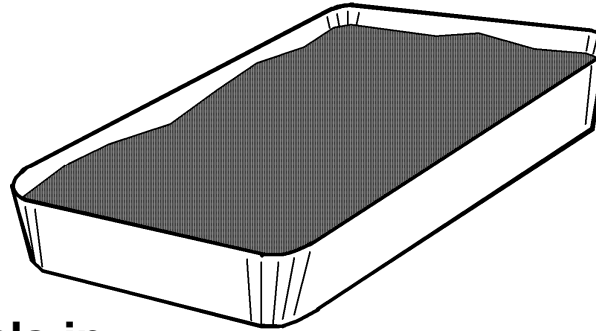

meals in  
aluminium bowl/dish

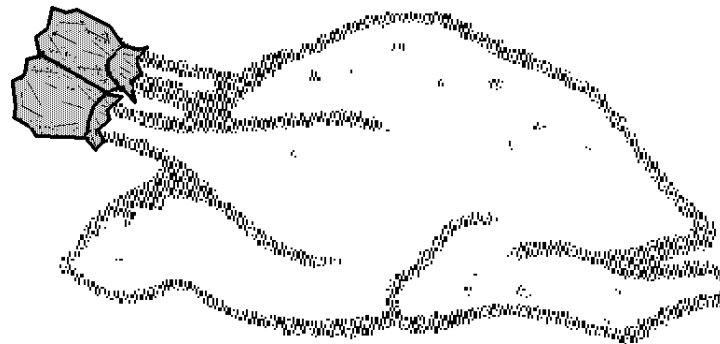

protect against dry out

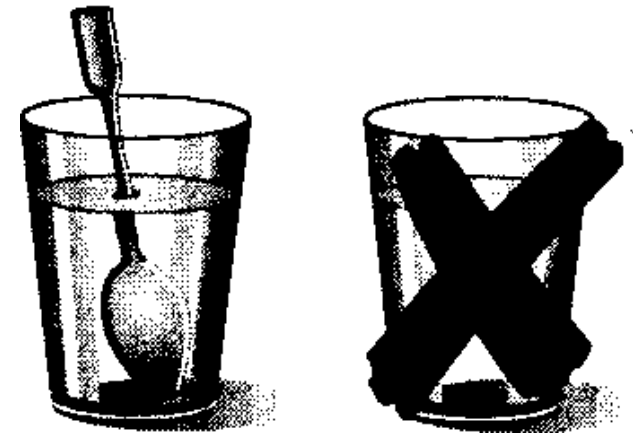

no delayed boiling

# Microwave Technic - Basic Training

## Basics general

---



**crunch - crisp - pizza etc.**

# Microwave Technic - Basic Training

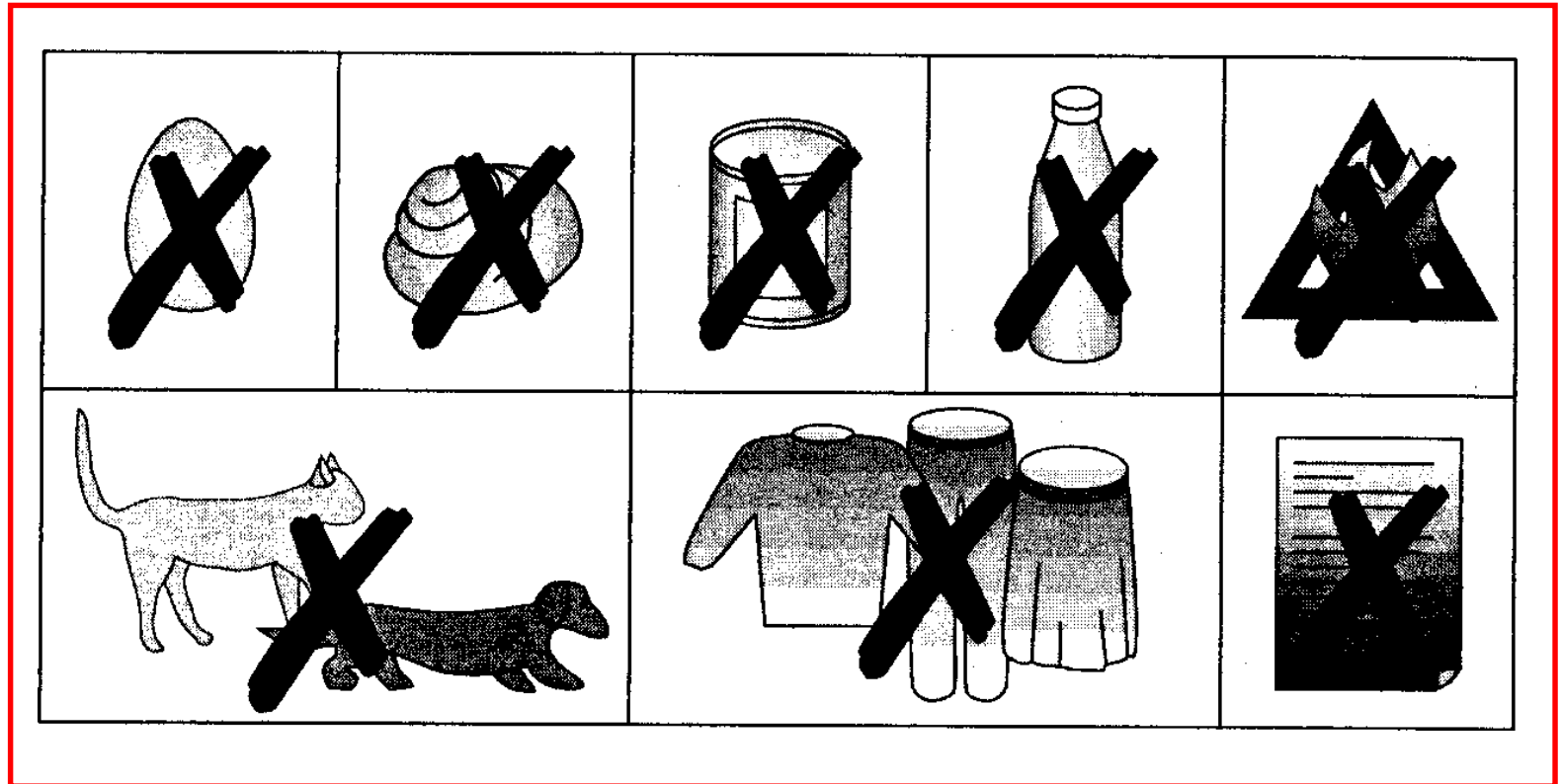

# Microwave Technic - Basic Training

## Basics electric

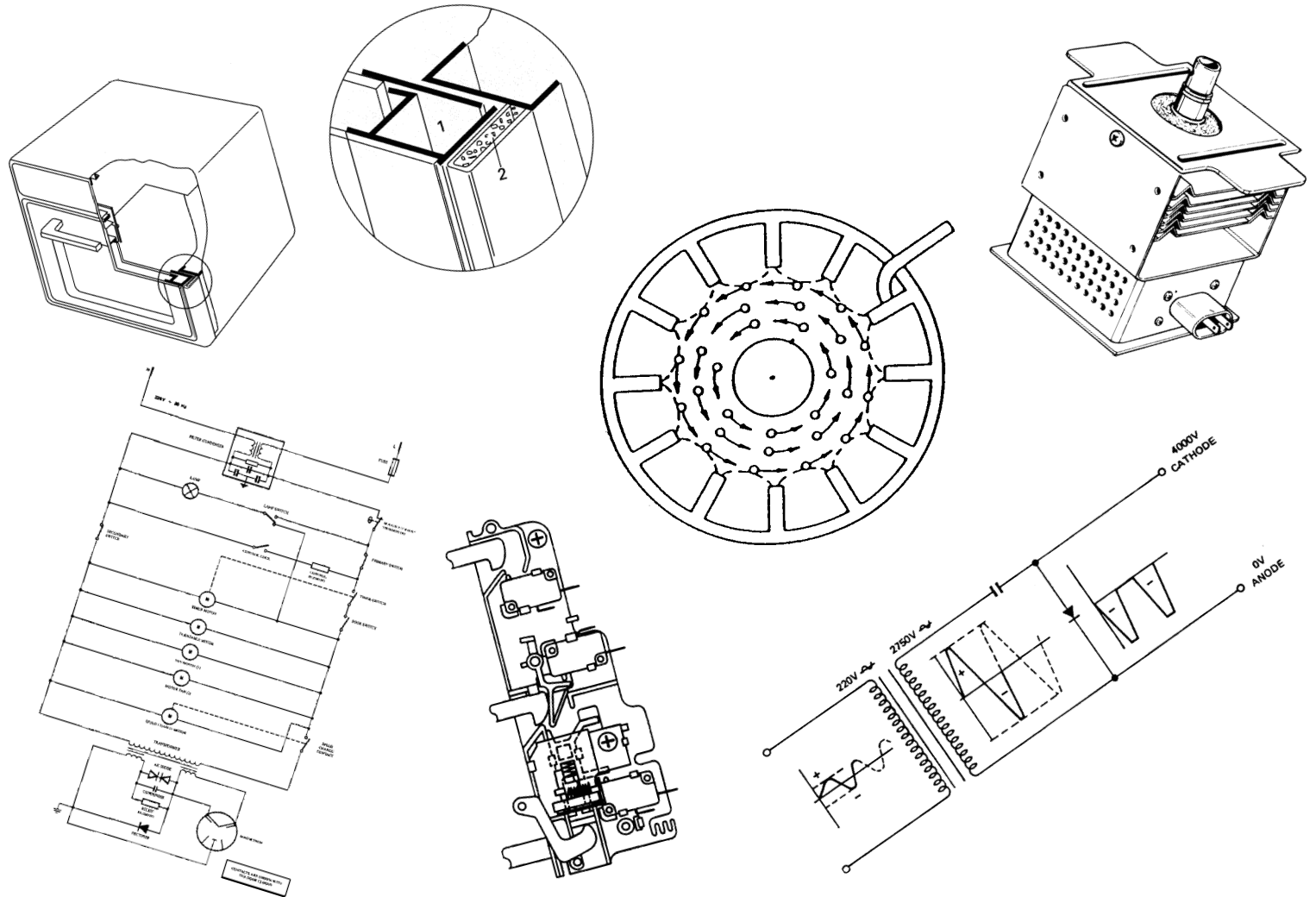

# Microwave Technic - Basic Training

## Basics electric

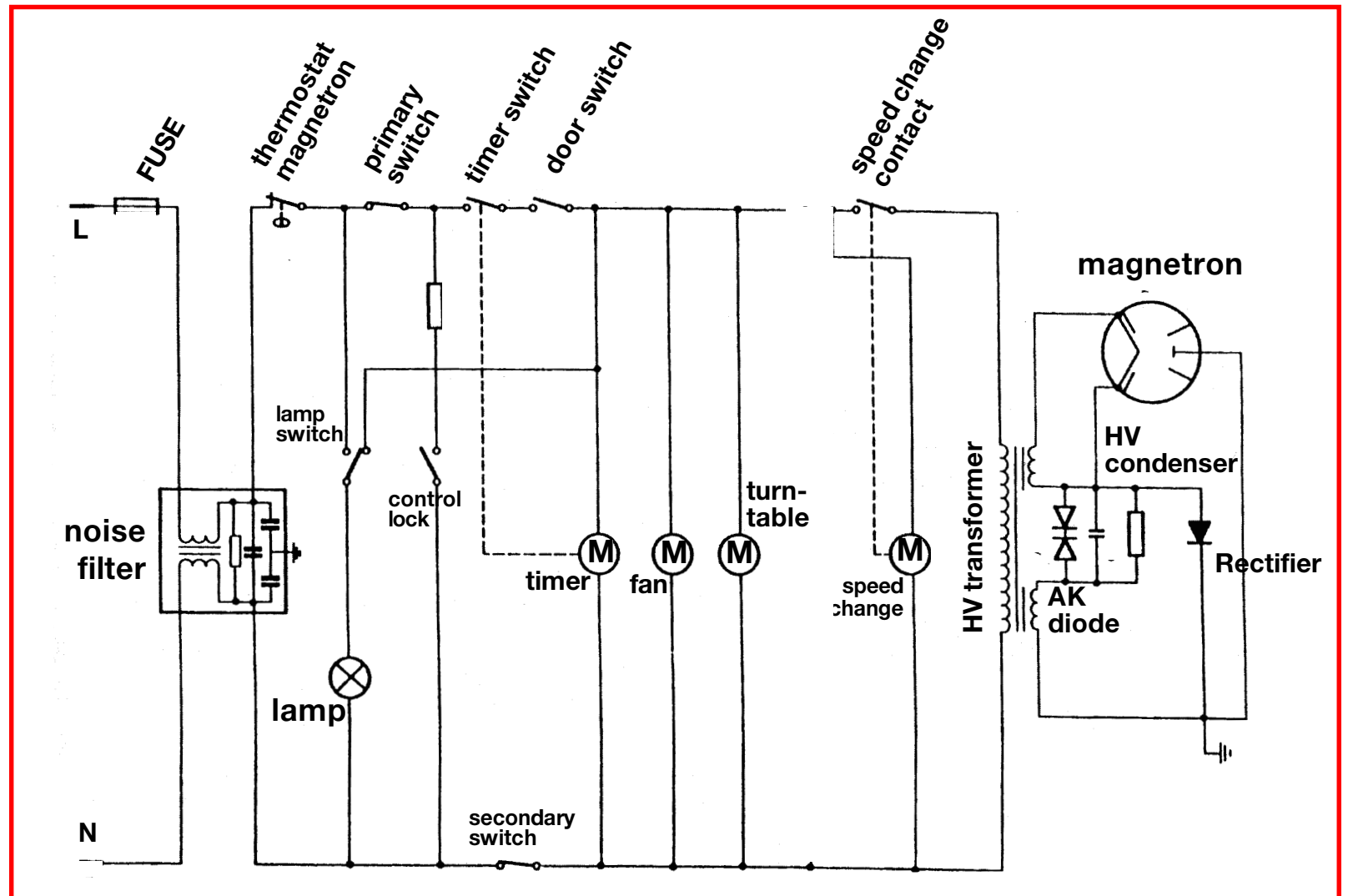

# Microwave Technic - Basic Training

## Basics electric

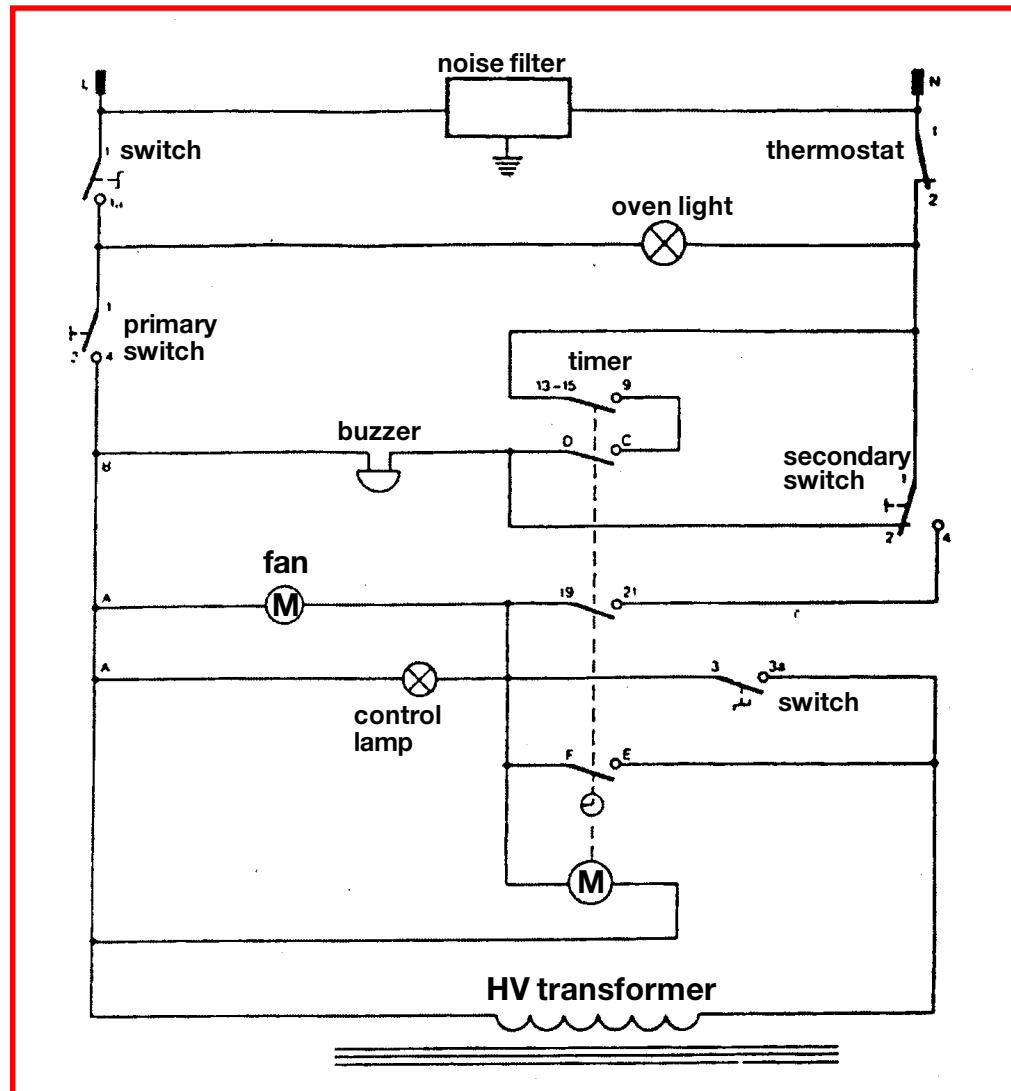



# Microwave Technic - Basic Training

## Basics electric

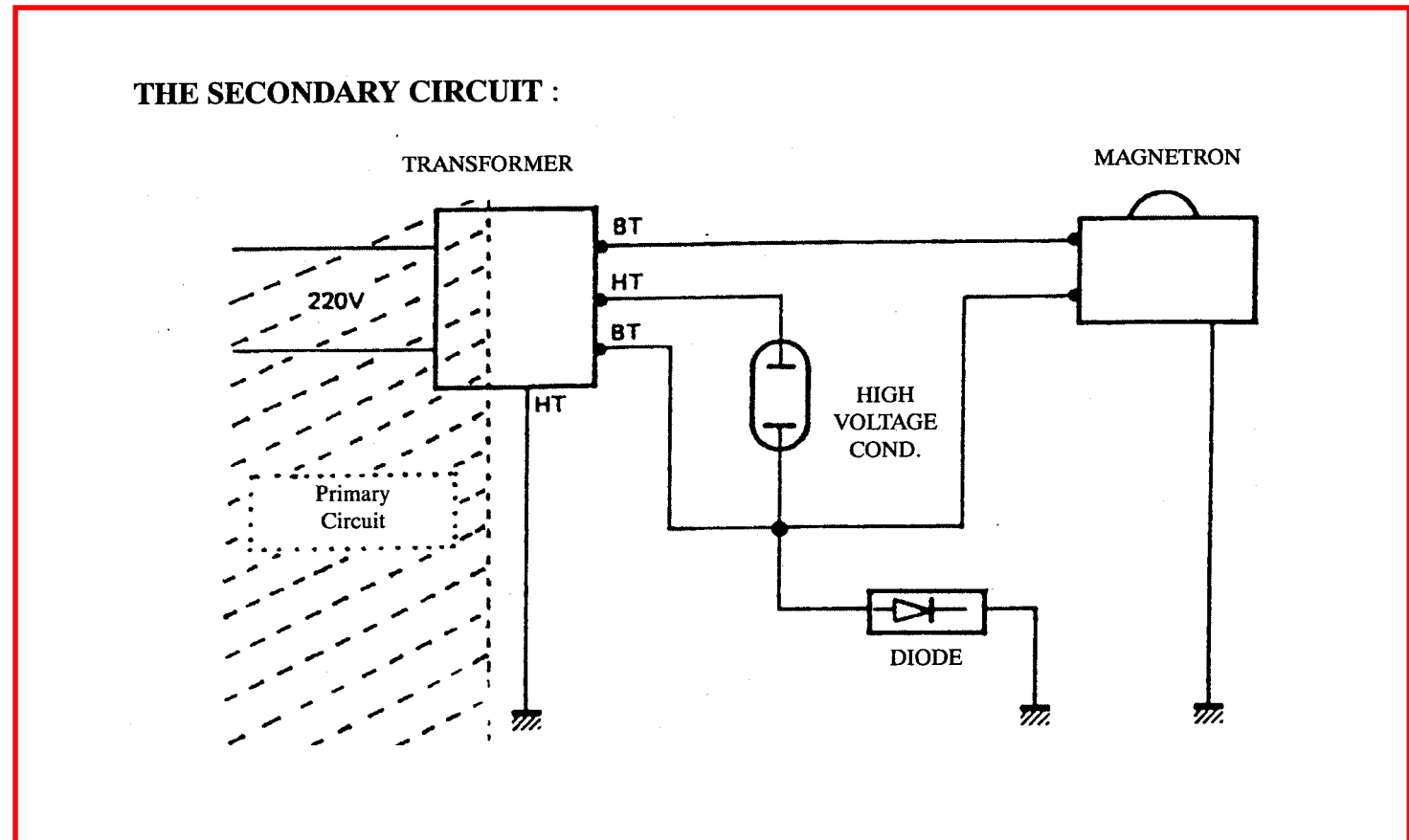

# Microwave Technic - Basic Training

## Basics electric

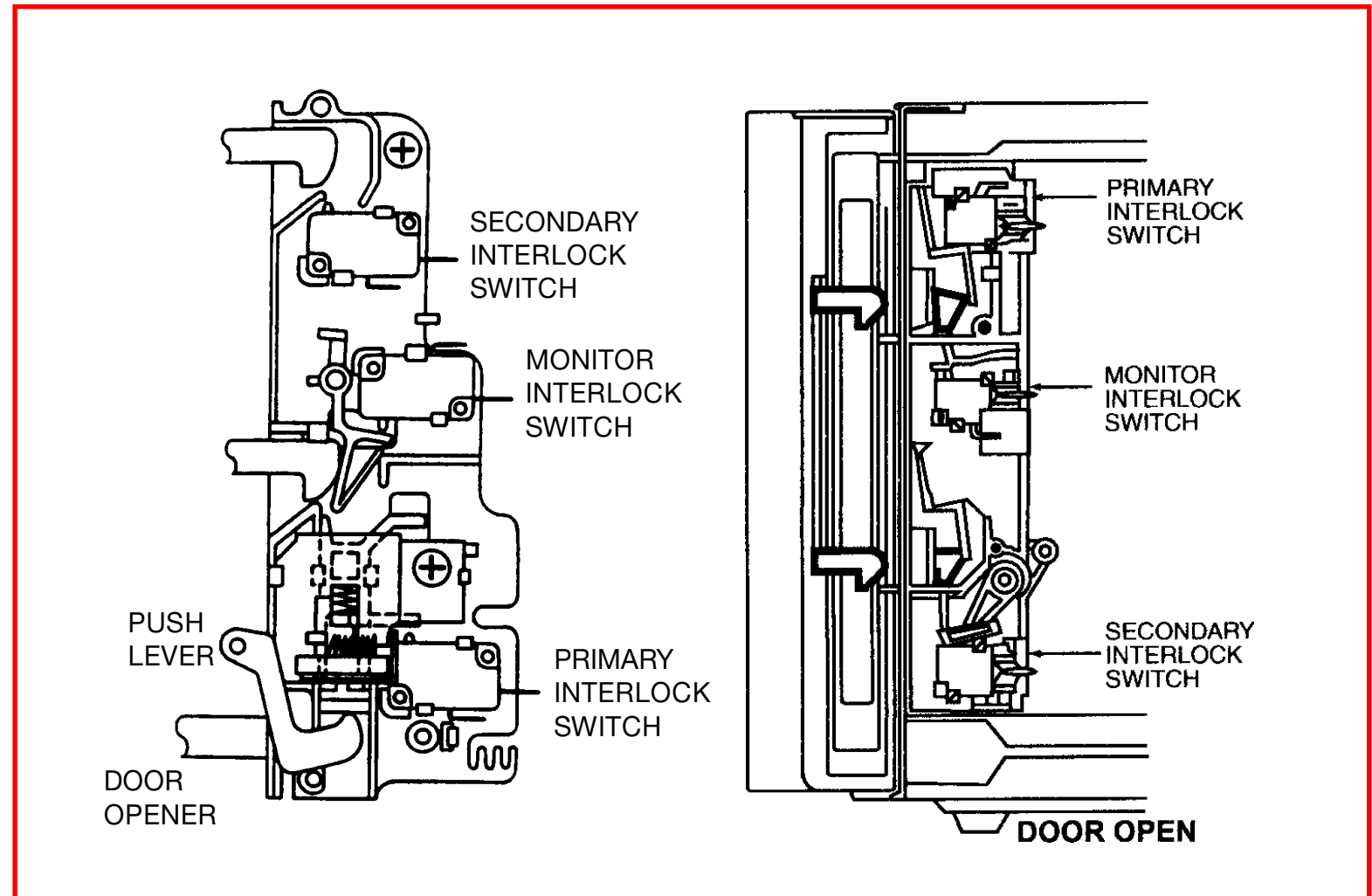

# Microwave Technic - Basic Training

## Basics electric

Security

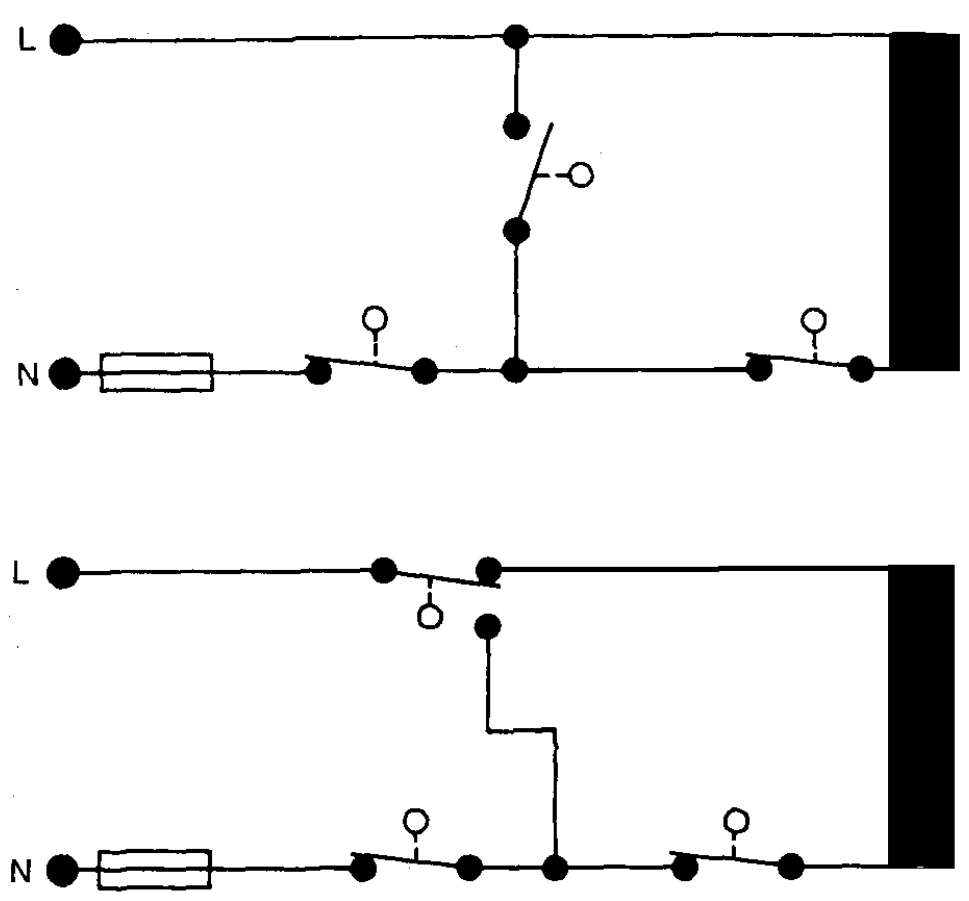

# Microwave Technic - Basic Training

## Basics electric

High voltage circuit

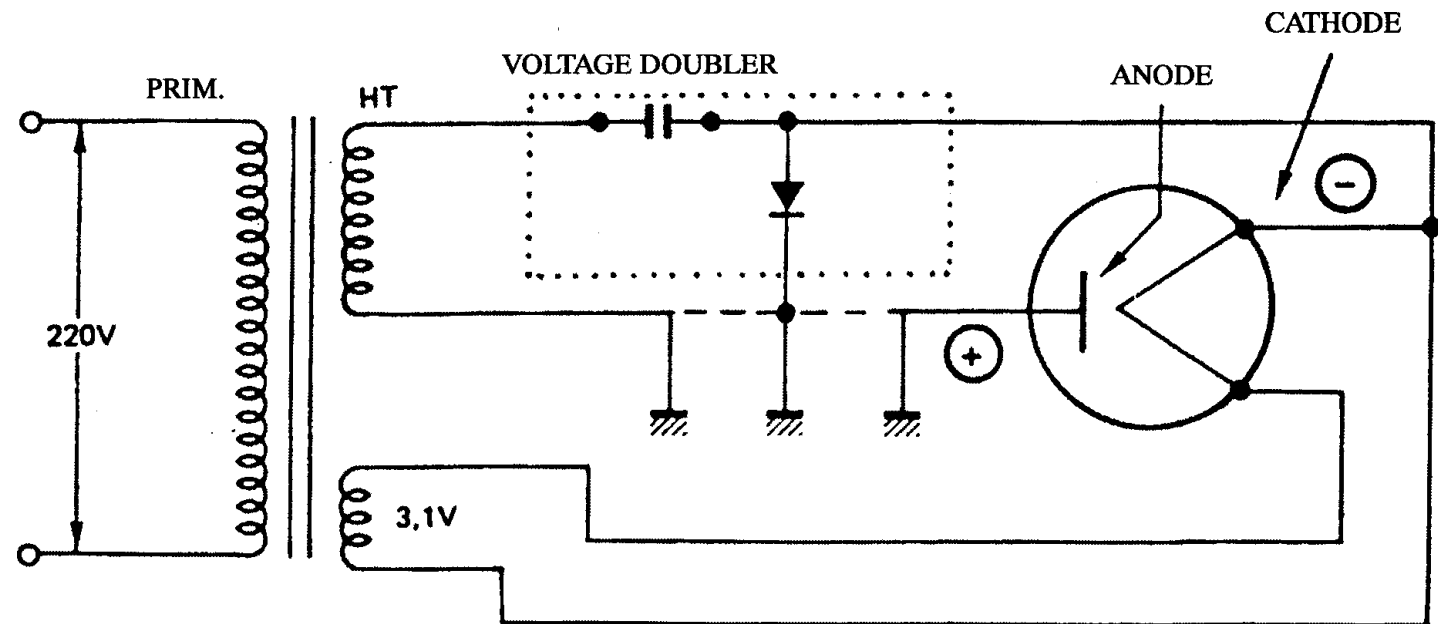

# Microwave Technic - Basic Training

## Basics electric

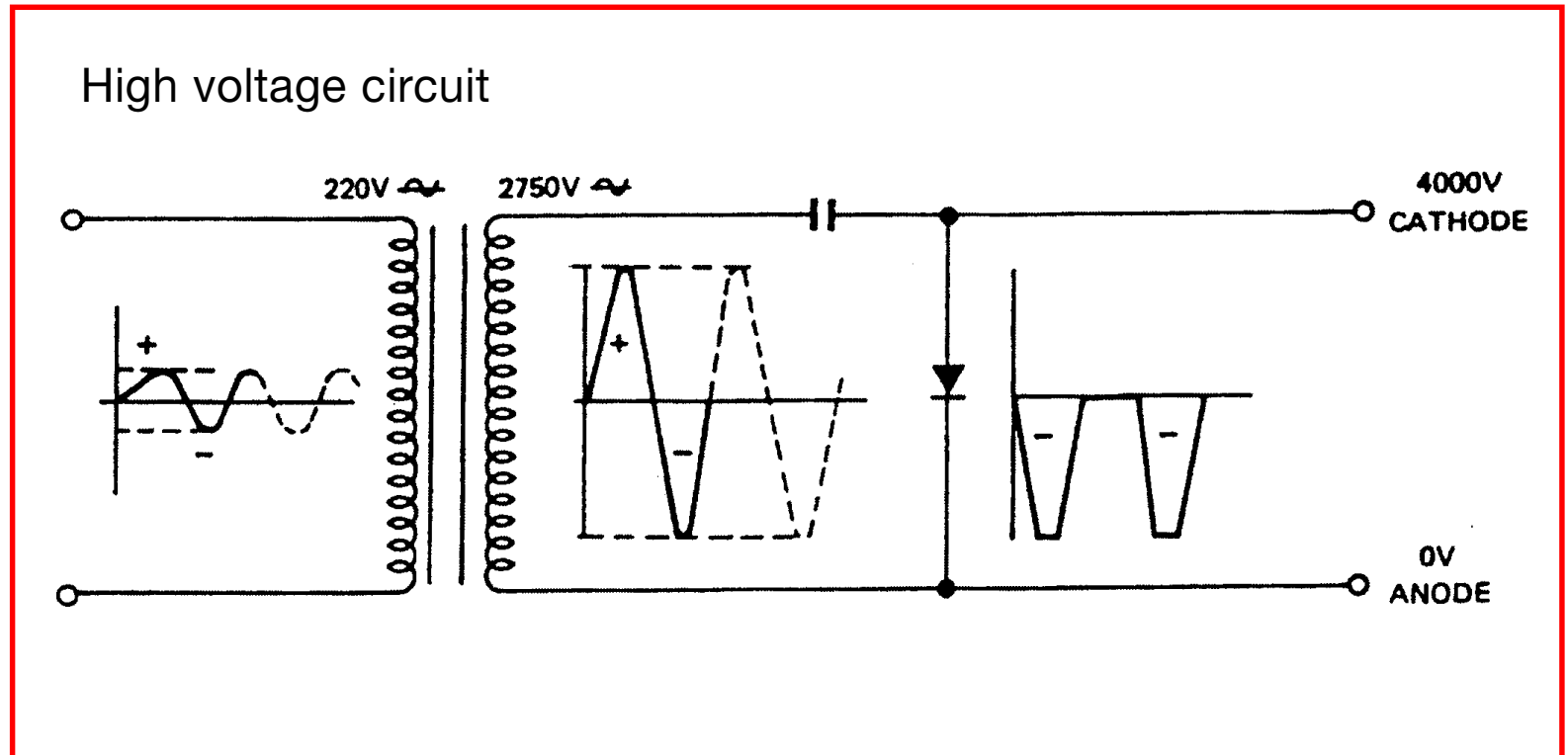

# Microwave Technic - Basic Training

## Basics electric

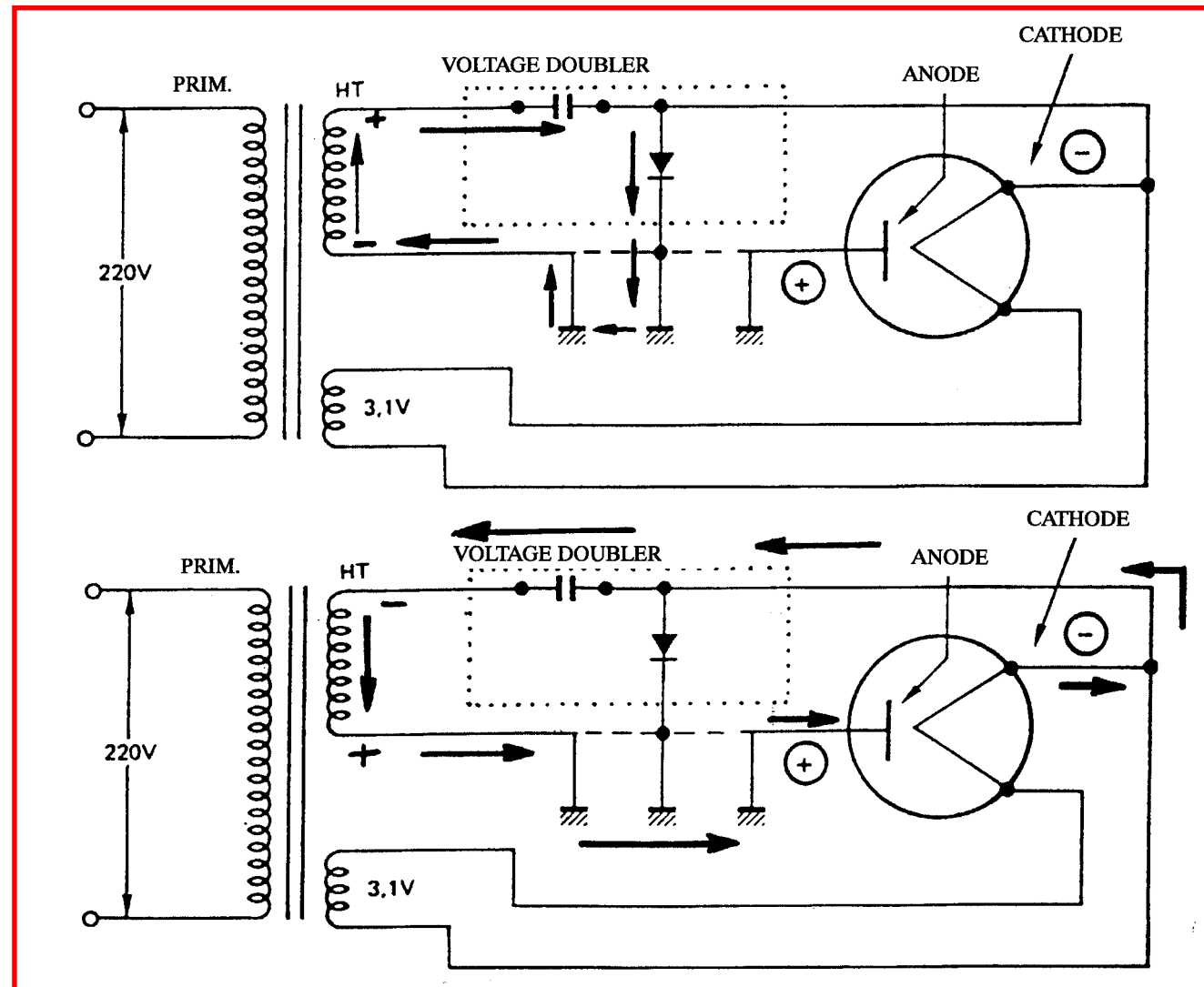

# Microwave Technic - Basic Training

## Basics electric

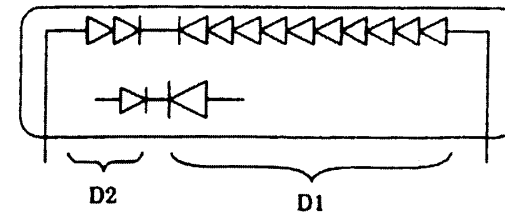

REVERSE STRAIN VOLTAGE :  $V_{r2} = 1200 \text{ V}$ ,  $V_{r1} = 6000 \text{ V}$

### NORMAL OPERATION

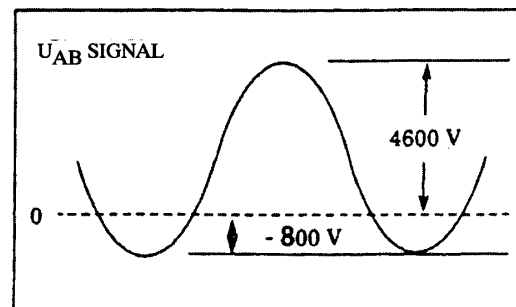
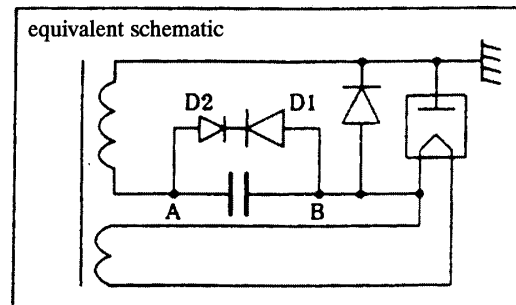

### SHORT-CIRCUITED DIODE

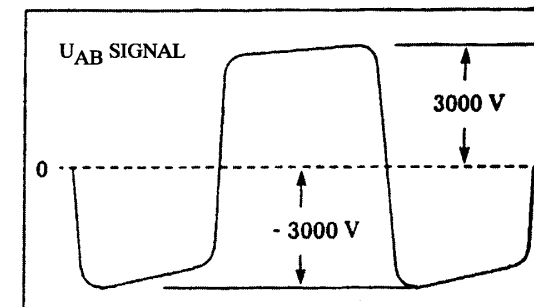
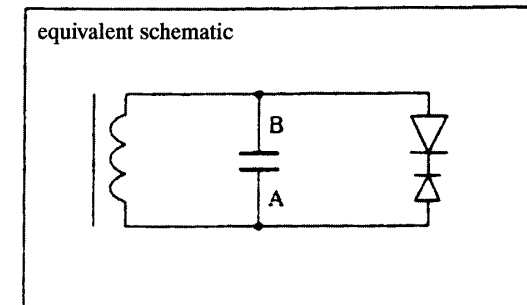

# Microwave Technic - Basic Training

## Basics electric

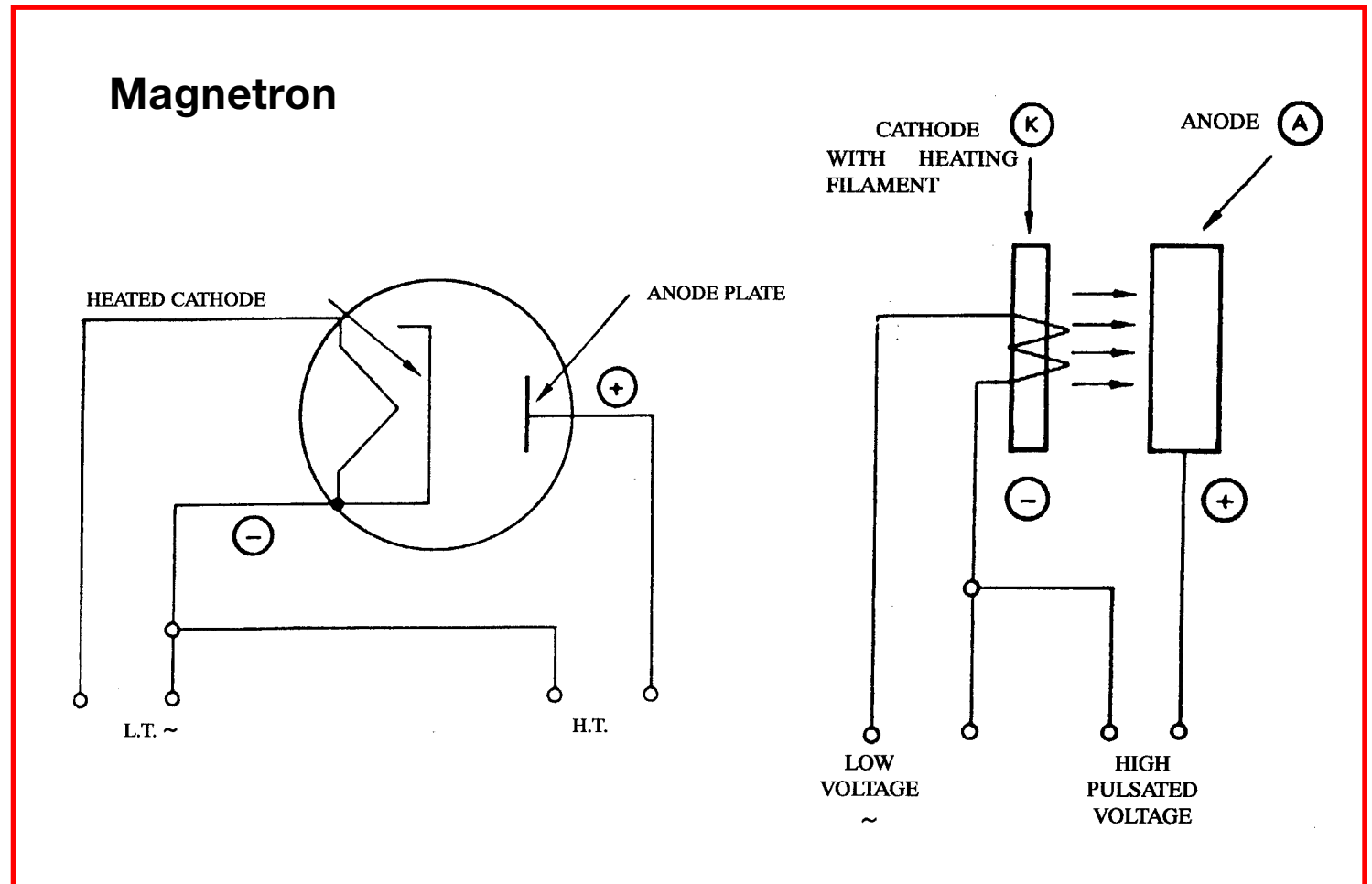



# Microwave Technic - Basic Training

## Basics electric

### Magnetron

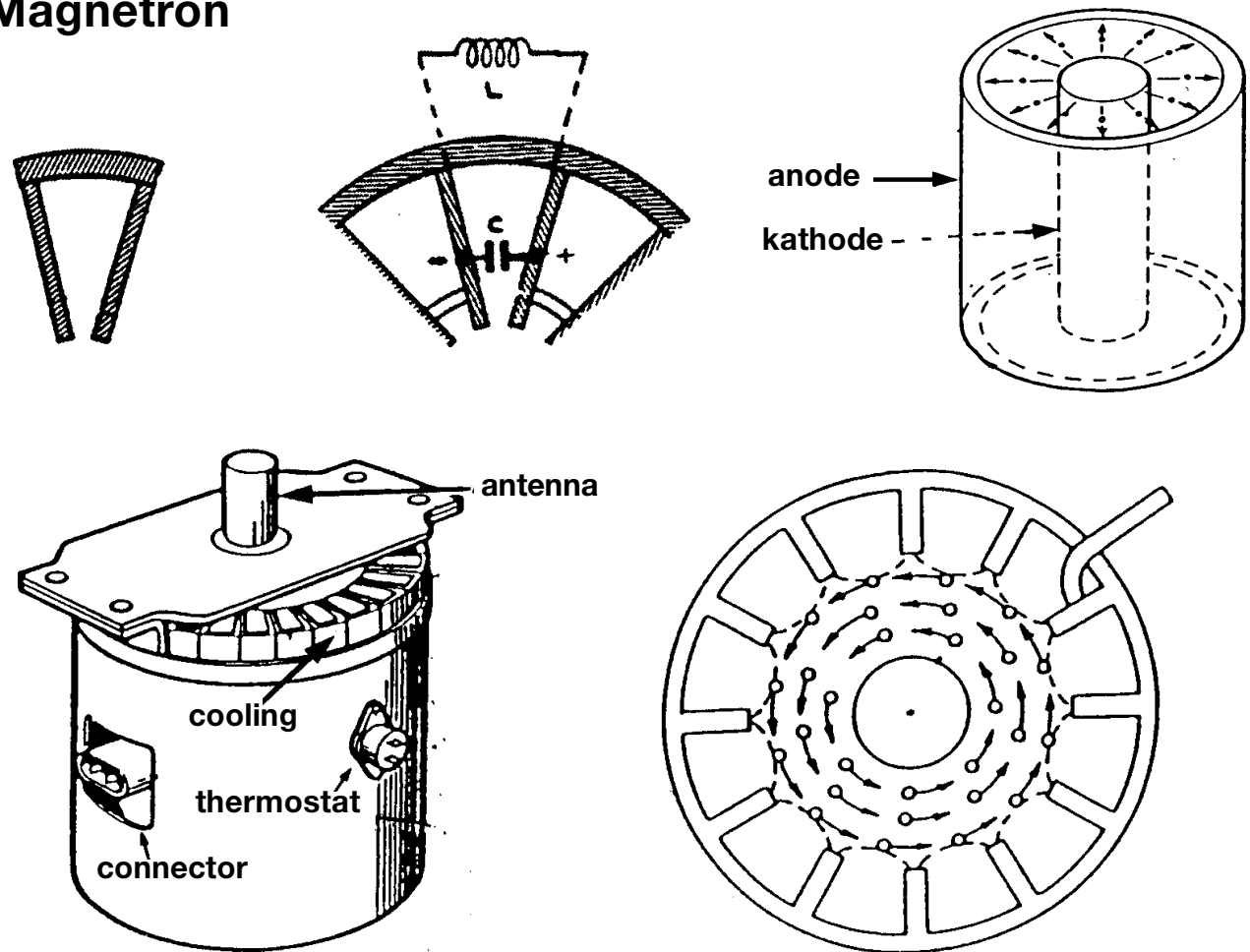

# Microwave Technic - Basic Training

## Basics electric

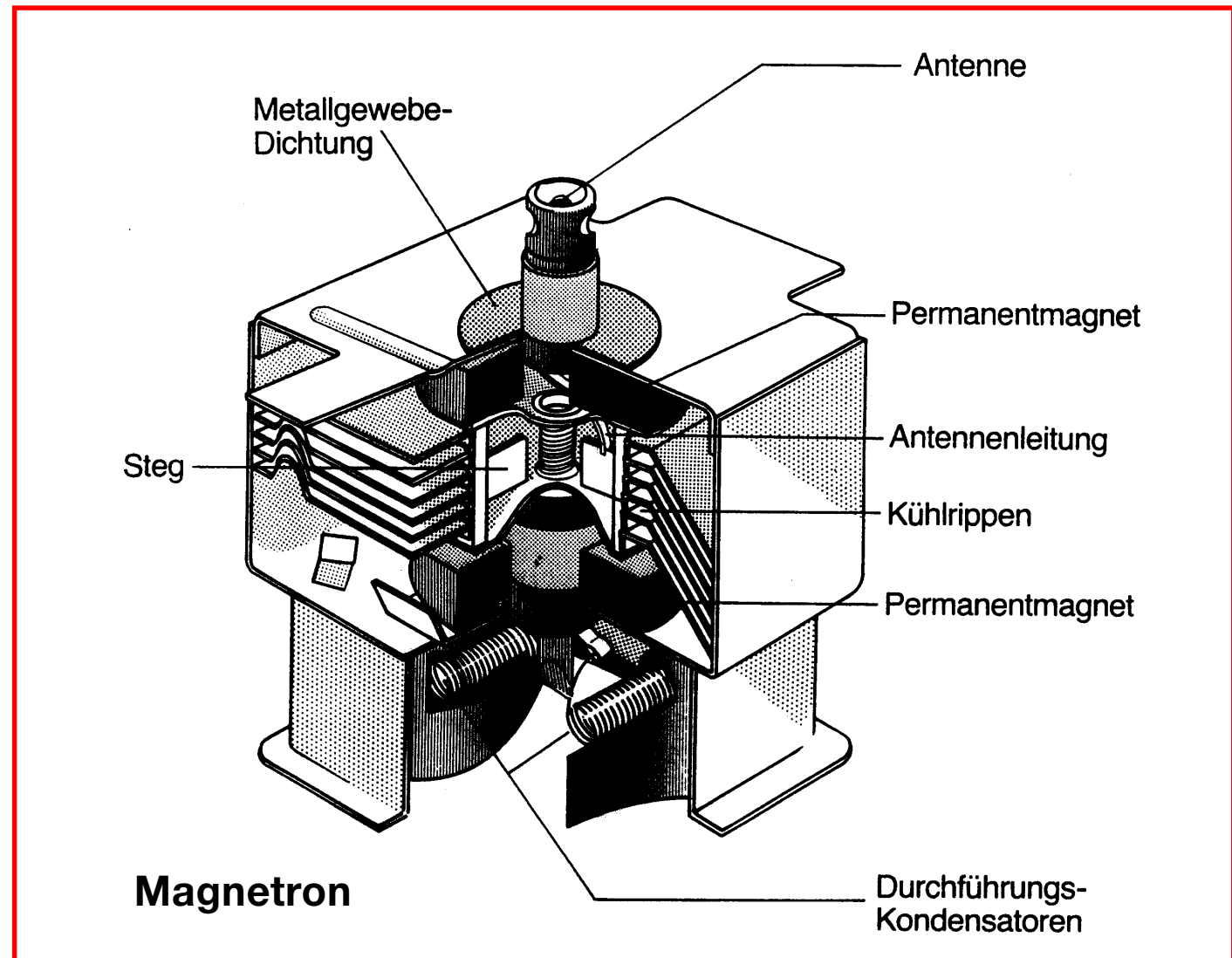

# Microwave Technic - Basic Training

## Basics electric

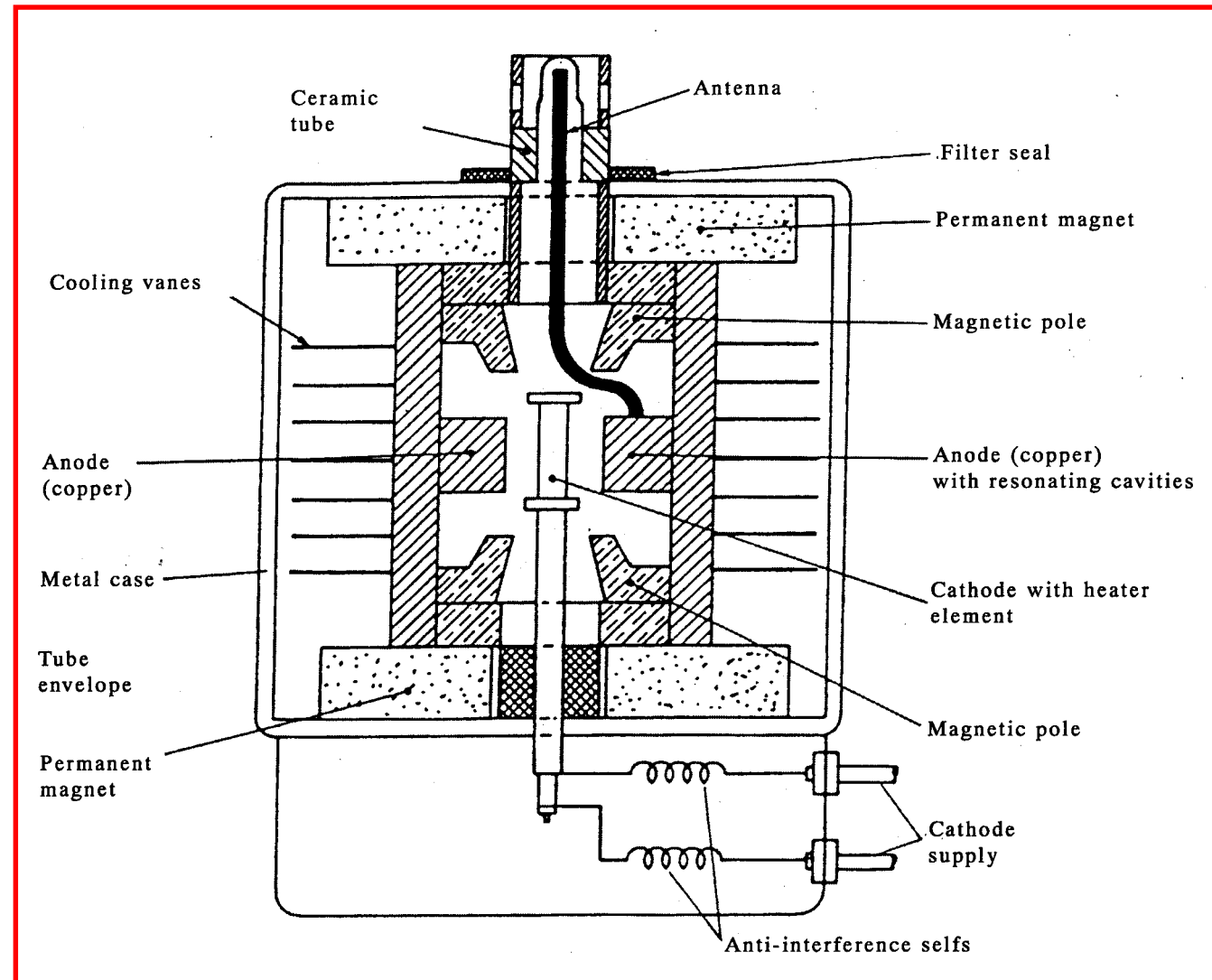

# Microwave Technic - Basic Training

## Measurements

### CAUTION

This device is to be serviced only by properly qualified service personnel. Consult the Service Manual for proper service procedures to assure continued safe operation and for precautions to be taken to avoid possible exposure to excessive microwave energy.

### CAUTION

#### MICROWAVE RADIATION

**DO NOT BECOME EXPOSED TO RADIATION FROM THE MICROWAVE GENERATOR OR OTHER PARTS CONDUCTING MICROWAVE ENERGY.**

ALL INPUT AND OUTPUT MICROWAVE CONNECTIONS, WAVEGUIDES, FLANGES, AND GAS-KETS MUST BE SECURED.

NEVER OPERATE THE APPLIANCE WITHOUT A MICROWAVE ENERGY ABSORBING LOAD ATTACHED.

NEVER LOOK INTO AN OPEN WAVEGUIDE OR ANTENNA WHILE THE DEVICE IS ENERGIZED.

### PRECAUTIONS TO BE OBSERVED BEFORE AND DURING SERVICING TO AVOID POSSIBLE EXPOSURE TO EXCESSIVE MICROWAVE ENERGY

- (a) Do not operate or allow the oven to be operated with the door open.
- (b) Make the following safety checks on all ovens to be serviced before activating the magnetron or other microwave source, and make repairs as necessary: (1) Interlock operation, (2) proper door closing, (3) seal and sealing surfaces (arcing, wear, and other damage), (4) damage to or loosening of hinges and latches, and (5) evidence of dropping or abuse.
- (c) Before turning on microwave power for any service test or inspection within the microwave generating compartments, check the magnetron, wave guide or transmission line, and cavity for proper alignment, integrity and connections.
- (d) Any defective or misadjusted components in the interlock, monitor, door seal, and microwave generation and transmission systems shall be repaired, replaced, or adjusted by procedures described in this manual before the oven is released to the owner.
- (e) A microwave leakage check to verify compliance with the performance standard should be performed on each oven prior to release to the owner.

### DANGER OF HIGH VOLTAGE

4000 volts exist at the high voltage area. (Refer to attached wiring diagram.)

Do not remove the cabinet parts unless the power cord is unplugged from wall outlet.

Do not operate the oven with the cabinet parts removed.

Be sure to short both terminal of the high voltage capacitor to ground with an insulated screwdriver before servicing.

Do not start repair work unless the high voltage capacitor is completely discharged.

# Microwave Technic - Basic Training

## Measurements

### Power measuring

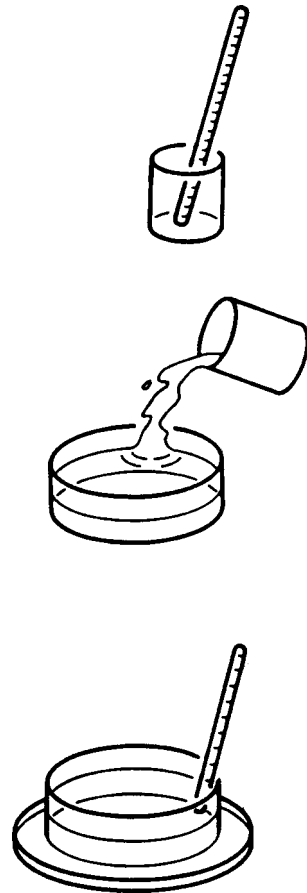

1 liter of water (17-24°C)  
62 seconds full power

temperature difference (C°)	MW-output power (W)
7	490
8	560
9	630
10	700
11	770
12	840
13	910
14	980
15	1050
16	1120
17	1190

# Microwave Technic - Basic Training

## Measurements

### Inspection for leakage

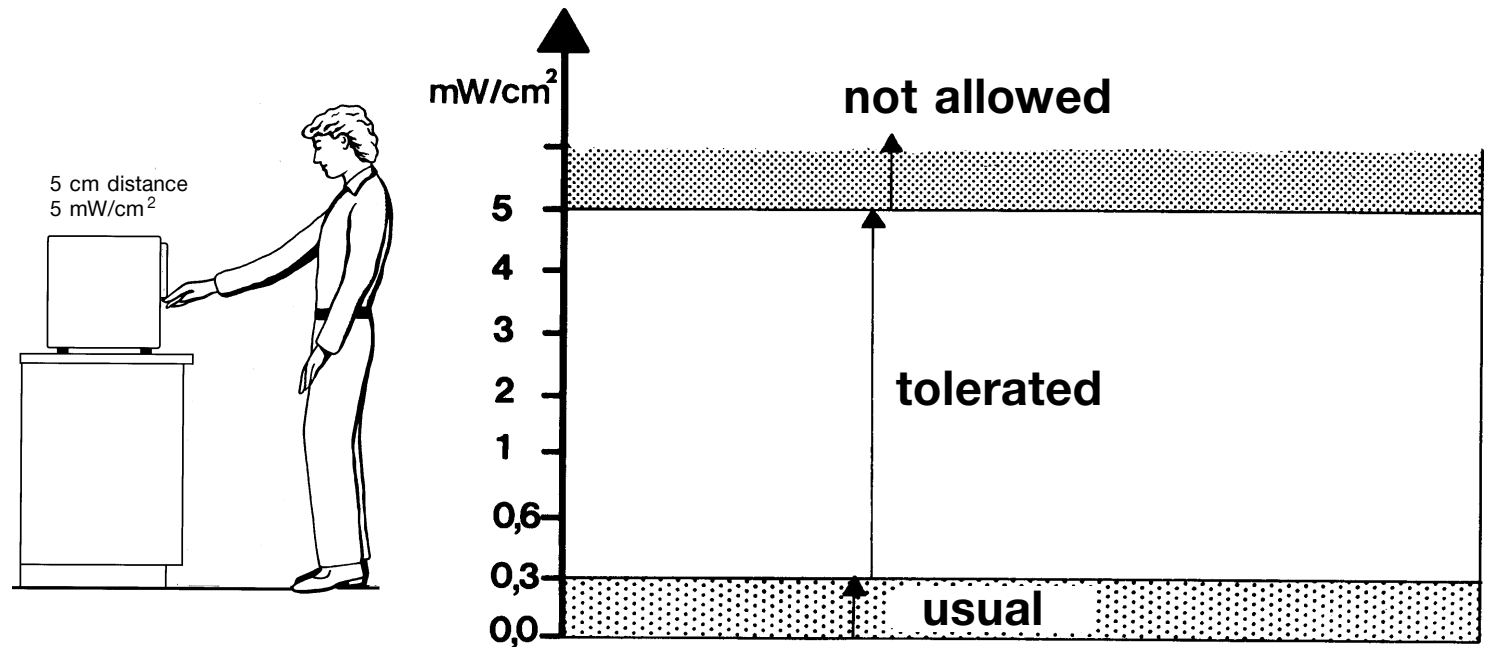

# Microwave Technic - Basic Training

## Measurements

### Inspection for leakage

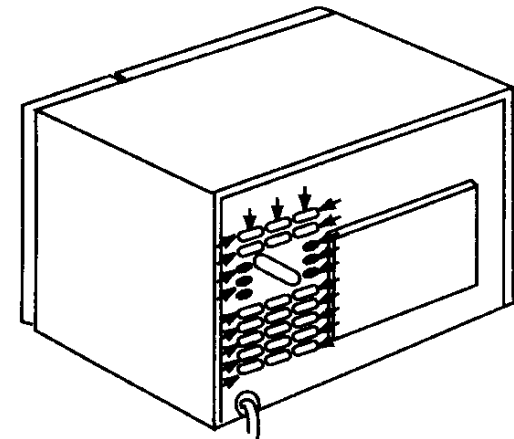
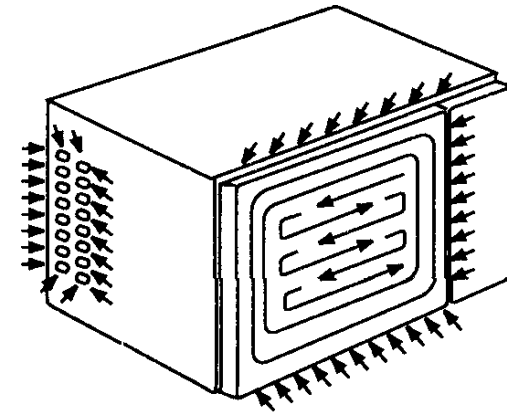

# Microwave Technic - Basic Training

## Measurements

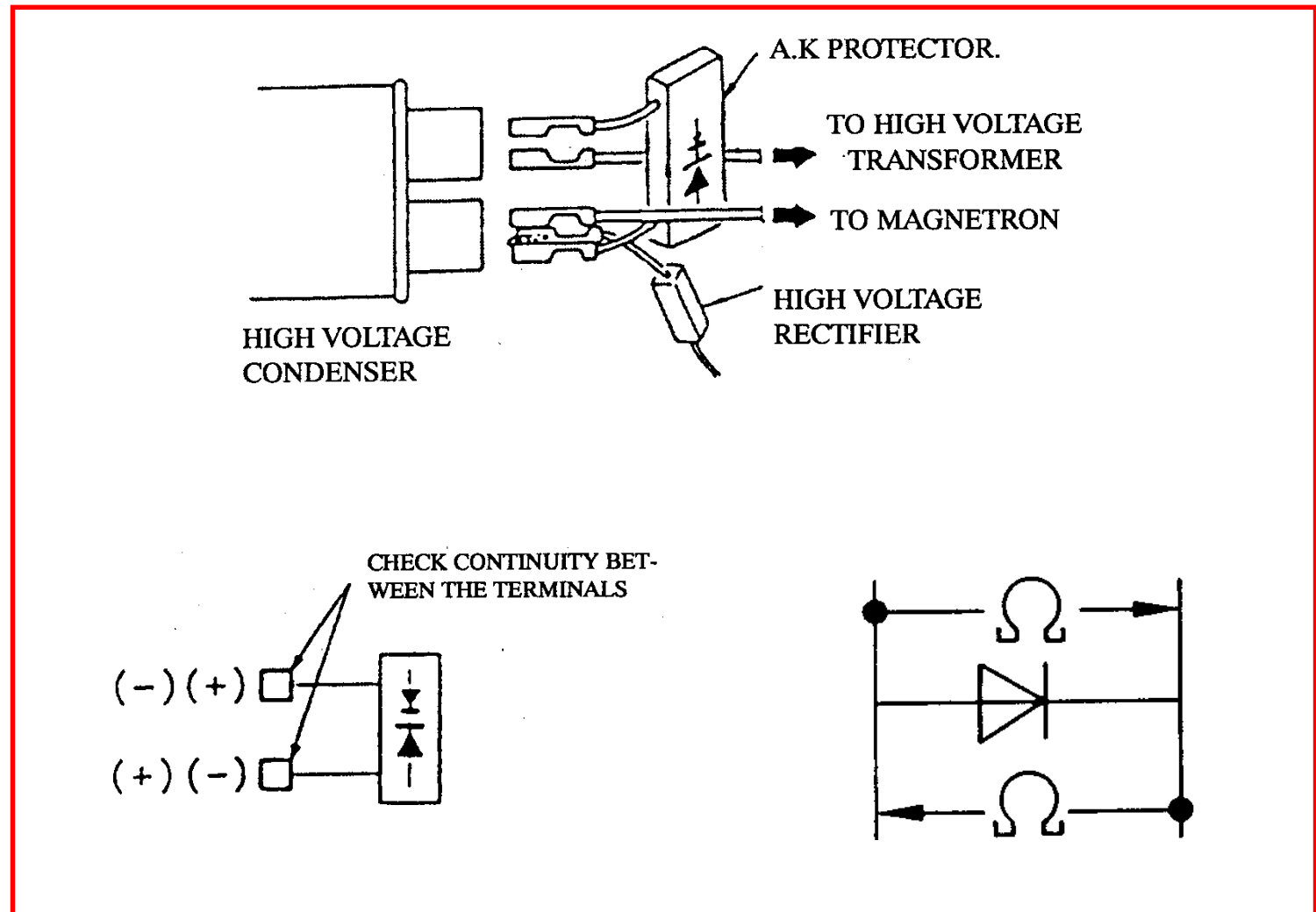



# Microwave Technic - Basic Training

## Measurements

### Magnetron

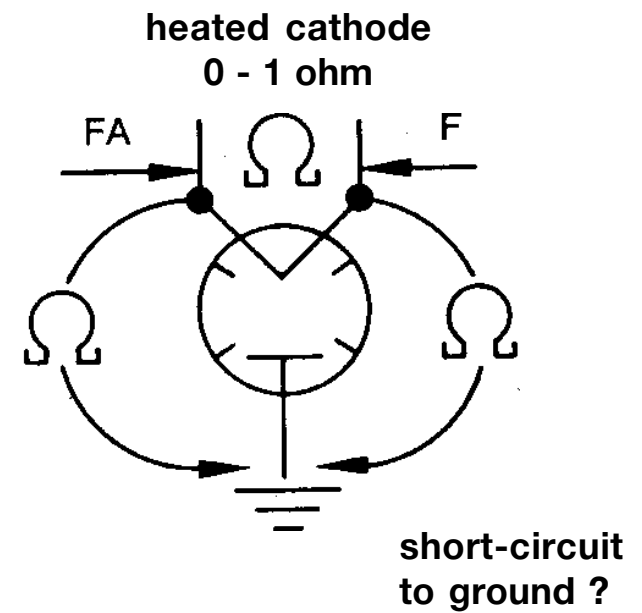
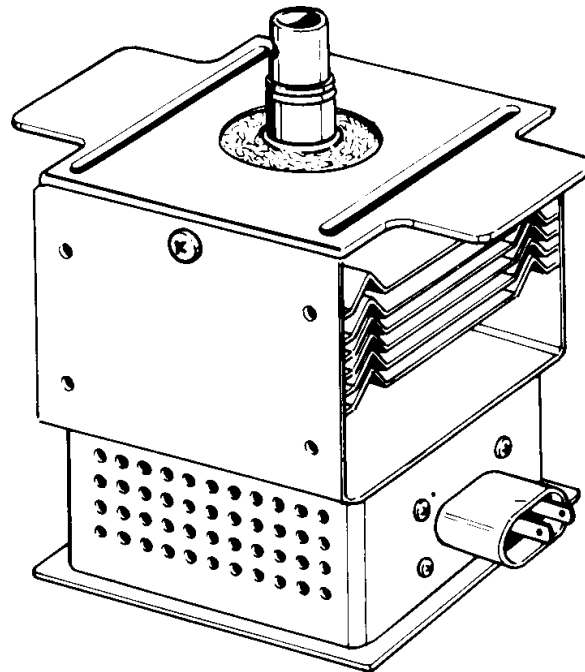

# Microwave Technic - Basic Training

## Measurements

### High voltage condenser

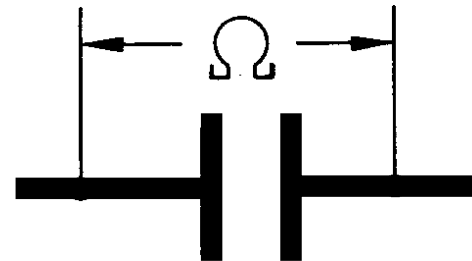

low resistance to high resistance = OK  
continuous low resistance = short circuit  
continuous very high resistance = interruption

# Microwave Technic - Basic Training

## Measurements

### High voltage transformer

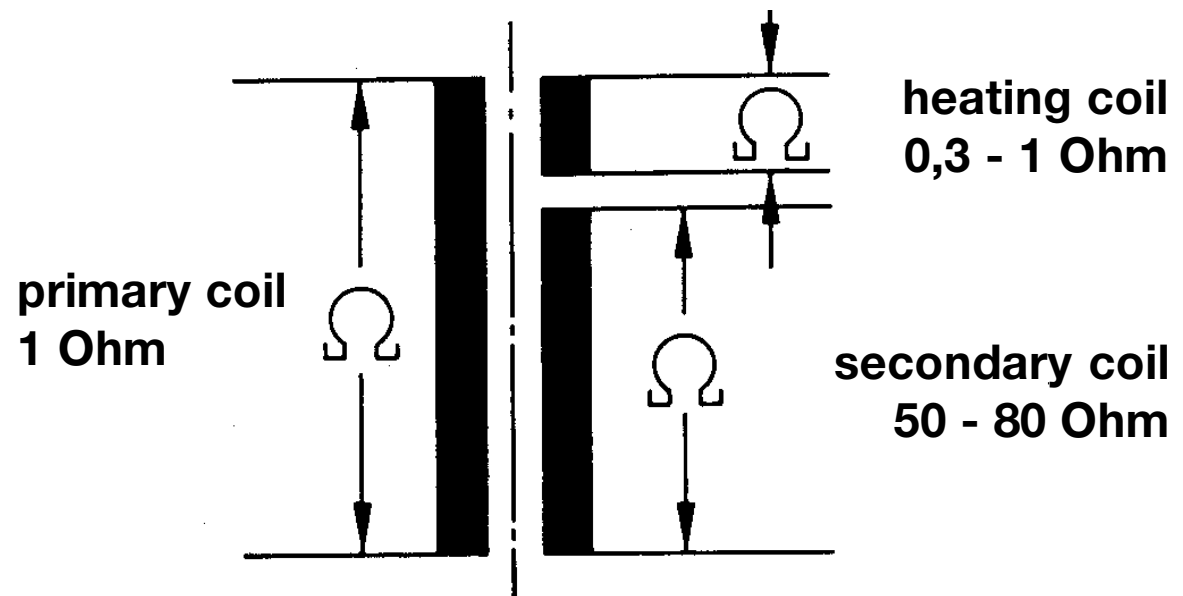

# Microwave Technic - Basic Training

## Measurements

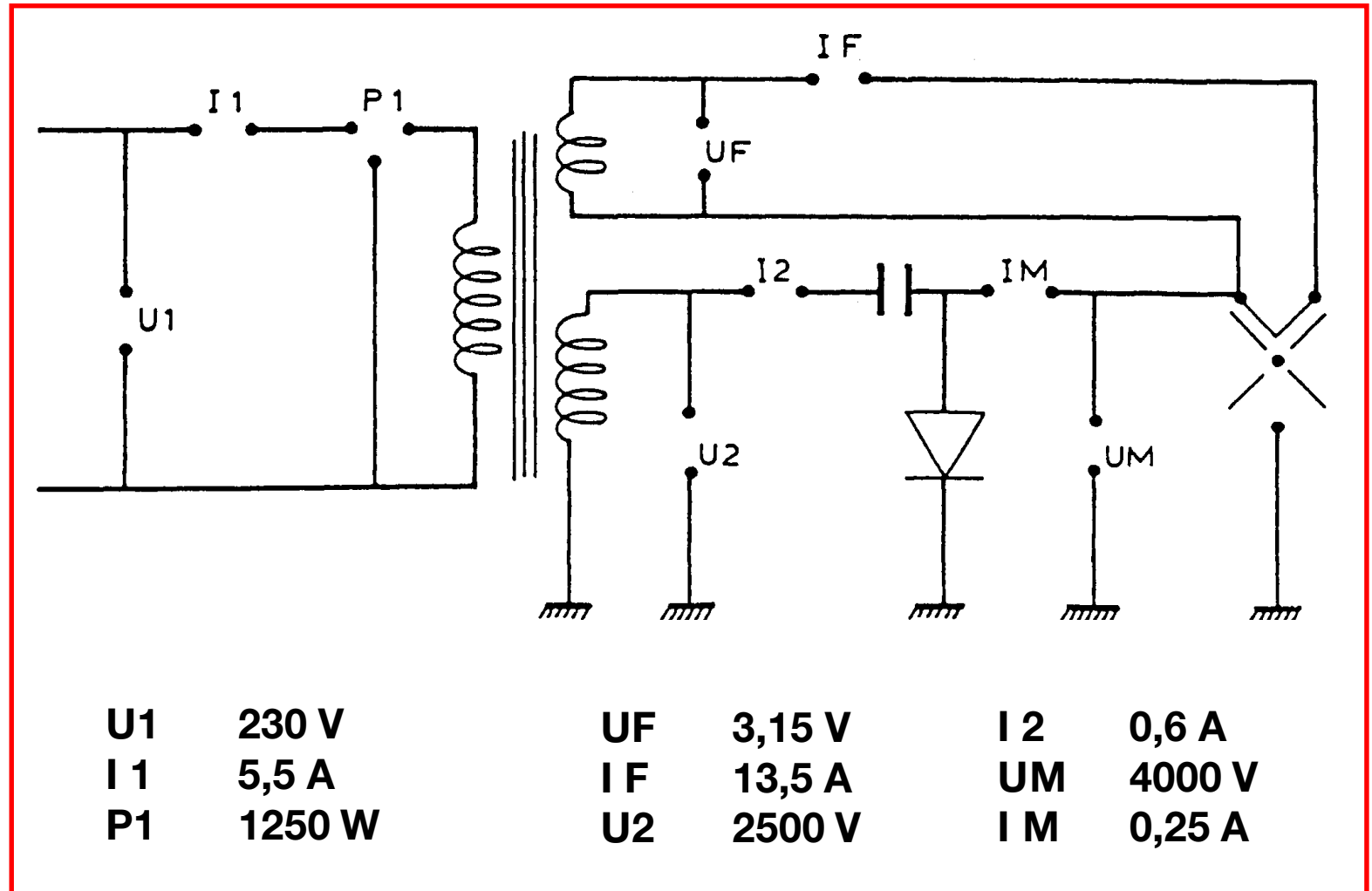

# Microwave Technic - Basic Training

## remaining

### different suppliers - different diagrams

Wiring Diagram – Model E24MG

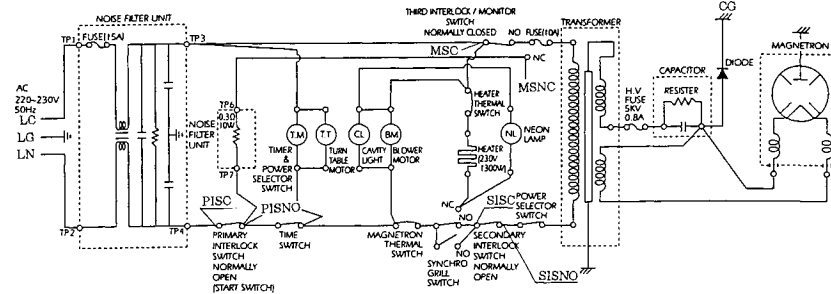

CONDITION :  
 DOOR : CLOSED  
 TIMER : ON  
 POWER SELECTOR SWITCH : MICROWAVE  
 START SWITCH : ON

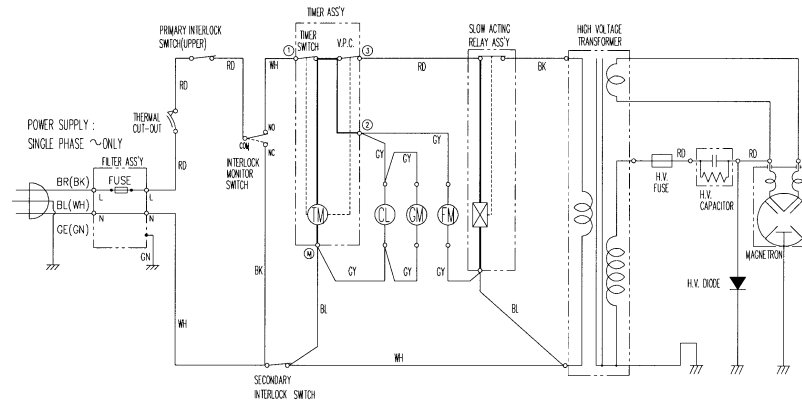

NOTE : RD : RED OR : ORANGE CL : CAVITY LAMP [ CONDITION ]  
 WH : WHITE BL : BLUE FM : FANBL (FAN) MOTOR DOOR : CLOSED  
 BK : BLACK CY : GRAY CM : CEARED MOTOR TIMER : ON  
 GN : GREEN CE : GREEN/YELLOW TM : TIMER MOTOR  
 BR : BROWN V.P.C. : VARIABLE POWER CONTROLLER

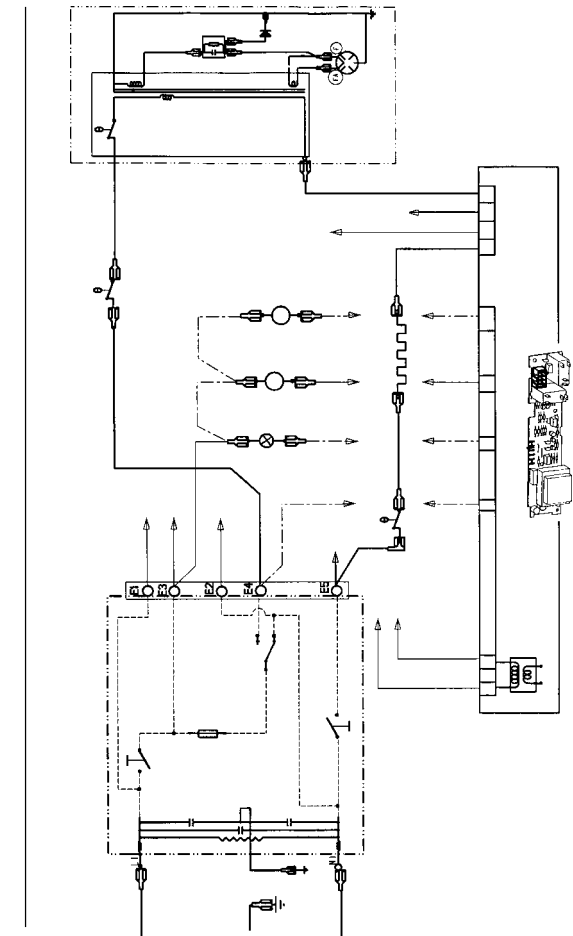

# Microwave Technic - Basic Training

## Troubleshooting

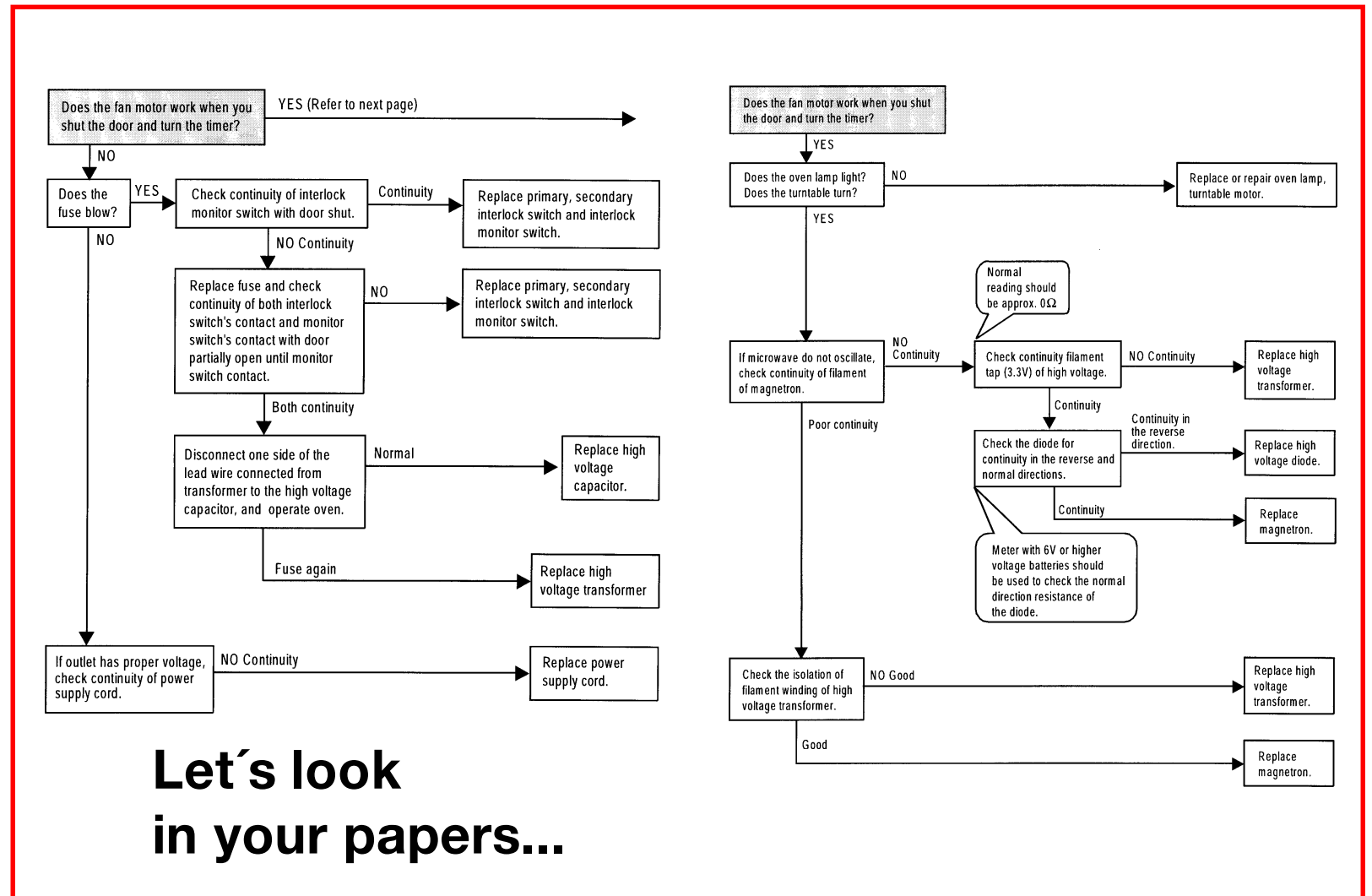

Let's look  
in your papers...