

Electrolux

SPARE PARTS LIST

Split RAC
(Cool only, Heat & Cool)
4150



Item	PNC	ELC	Brand	Model	Market
A	956004717	00	Electrolux	ESV12CRR-B4	THE
A	956004741	00	Electrolux	ESV12CRR-B4I	THE
A	956004765	00	Electrolux	ESV12CRR-B4E	THE

SAFETY WARNING

Always turn off and unplug the machine before detaching any parts.

When servicing machines, do not remove ANY detachable parts while the machine is powered. The reason is internal faults may cause shorts to components that are normally at low voltage presenting a shock hazard.

Electrolux Thailand Co.,Ltd.
1910 Electrolux Building
New Petchburi Rd. Bangkok
Huaykwang
Bangkok , 10310
Tel : +662 725 9000

Publication-No
2000415

Split RAC (Cool only,
Heat & Cool)

Model : ESV12CRR-B4I
PNC : 956004741 00

Ex. View Drawing
(Indoor Unit)



19.1

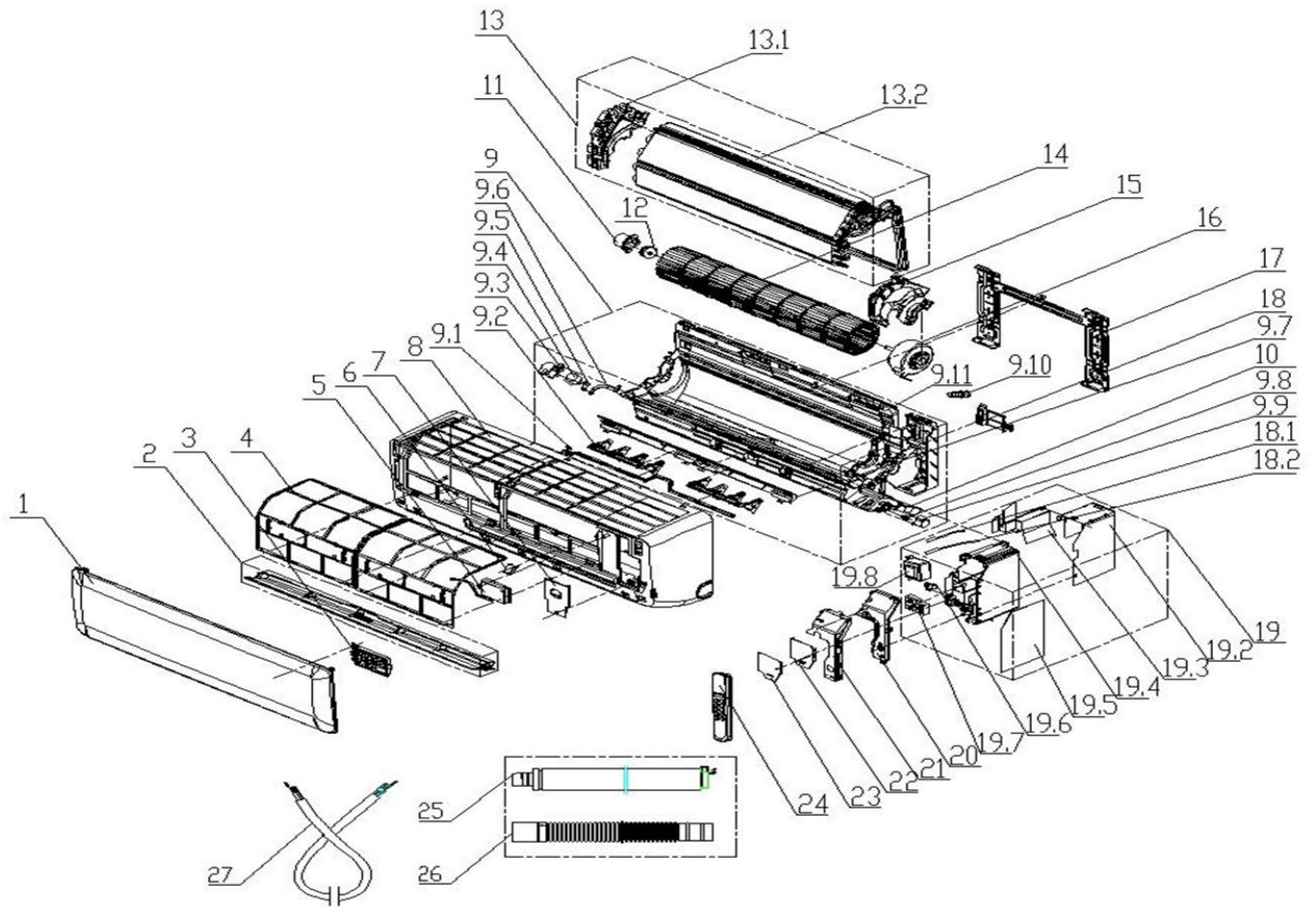

Item	PNC	ELC	Brand	Model	Market
A	956004741	00	Electrolux	ESV12CRR-B4I	THE

Item	Part #	Description	
1	13220598000065	PANEL	1
2	11320005000382	AIR LOUVER ASSEMBLY	1
3	11222014000650	DISPLAY BOARD	1
4	11220508000143	HEALTHY ANTI-BACTERIAL FILTER	2
5	11320076000063	MEDIUM FRAME WIRING COVER	1
6	11320096000105	SCREW COVER	2
7	11320002000306	MEDIUM FRAME	1
8	11220500000166	CHASSIS ASSEMBLY	1
8.1	11320017000118	SWING BLADE	2
8.2	11320135000016	AIR LOUVER	1
8.3	11320079000010	SHAFT SLEEVE	1
8.4	11320001000217	CHASSIS	1
8.5	11320079000013	STEP MOTOR SHAFT SLEEVE	1
8.6	11230002000058	STEP MOTOR	1
9	11320062000028	BEARING FIXED CHASSIS	1
10	11220551000003	BEARING ASSEMBLY	1
11	11224003000577	EVAPORATOR ASSEMBLY	1
11.1	11320015000113	EVAPORATOR LEFT SIDE CARRIAGE	1
11.2	11224009000200	EVAPORATOR ASSEMBLY	1
11.2	11224009000199	EVAPORATOR ASSEMBLY	1
12	11220513000068	CROSS FLOW FAN	1
13	11320052000032	MOTOR COVER	1
14	11320065000028	BREAKWATER	1
15	11230003000168	INDOOR FAN MOTOR	1
16	11321003000041	MOUNTING PLATE ASSEMBLY	1
17	11320084000015	PIPE CLAMP	1
18	13222002002560	MAIN CONTROLLER	1
18.1	11321012000006	CONTROLLER BOX SHEET-METAL B	1
18.2	11320057000071	CONTROLLER BOX	1
18.4	11320049000007	POWER WIRE CLAMP	1
18.5	11330037000020	TERMINAL BOARD	1
19	11321012000005	CONTROLLER BOX SHEET-METAL A	1
20	11320010000037	POWER WIRE CABLE CLAMP	1
21	11321012000007	CONTROLLER BOX SHEET-METAL C	1
23	11222001000869	REMOTE CONTROLLER	1
25	11220506000009	WATER OUTLET ASSEMBLY	1
26	11320020000008	DRAINING PIPE	1
27	11333003000009	PLUG	1
999	11329013000103	INTEGRATED TEMPERATURE SENSOR	1

ESV12CRR-B4I
PNC956004741 00

Model : ESV12CRR-B4E
PNC : 956004765 00

Ex. View Drawing
(Outdoor Unit)

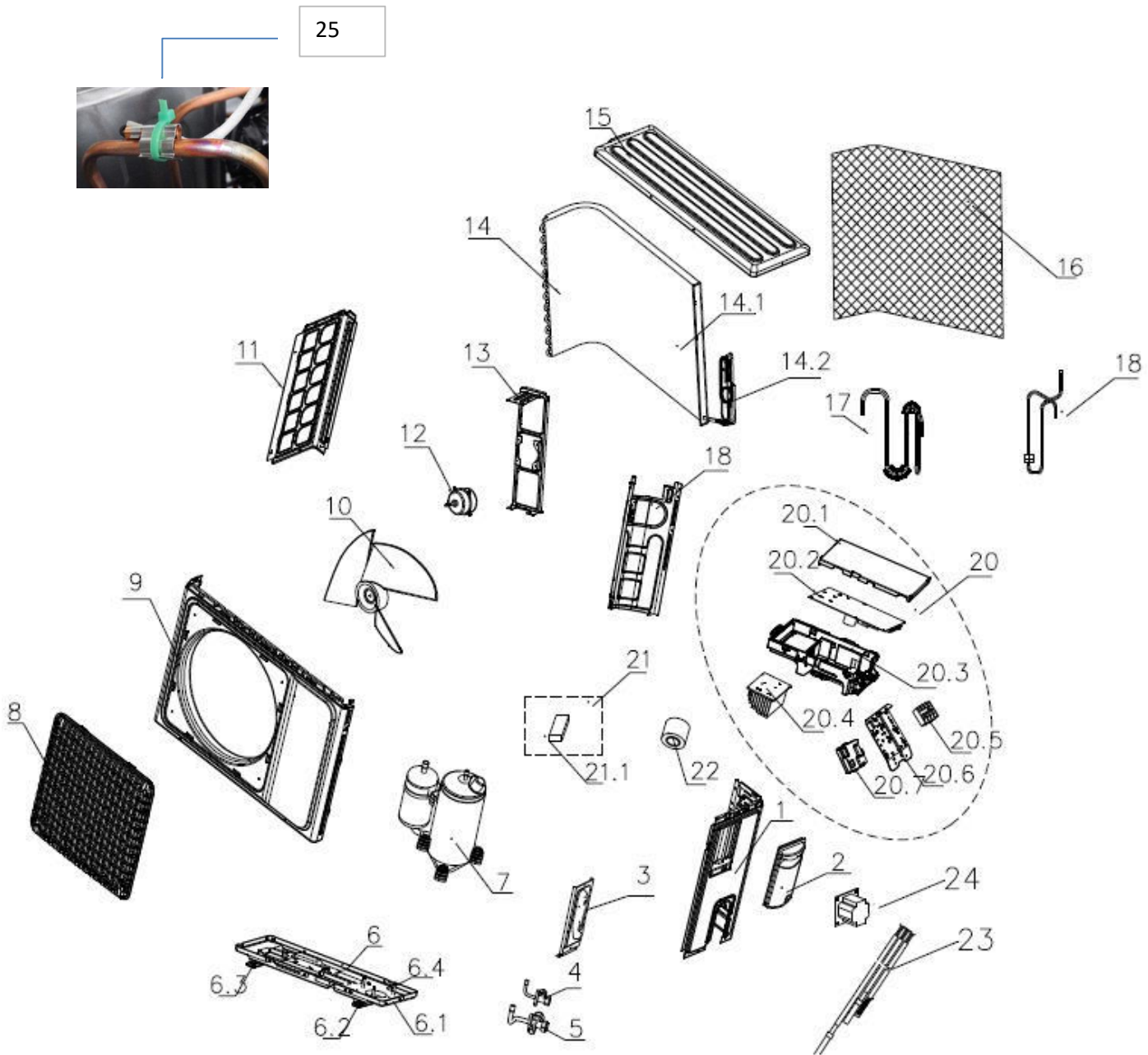

Item	PNC	ELC	Brand	Model	Market
A	956004765	00	Electrolux	ESV12CRR-B4E	THE

Pos.	Part No	Description	
1	11321007000304	RIGHT SIDE BOARD	1
2	11320101000033	E-PARTS COVER	1
3	11321031000027	VALVE PLATE	1
4	11325042000030	STOP VALVE	1
5	11225517000006	STOP VALVE	1
6	11221502000442	CHASSIS ASSEMBLY	1
6.1	11321014000144	CHASSIS	1
6.2	11321023000012	BASE FOOTING	2
6.4	14731005000064	BOLT	3
7	11223015000140	COMPRESSOR	1
8	11320026000046	PANEL GRILLE	1
9	11321005000104	PANEL	1
10	11320009000049	AXIAL FLOW FAN	1
11	11321006000108	LEFT SIDE BOARD	1
12	11230004000331	MOTOR	1
13	11321002000039	MOTOR SUPPORT	1
14	11224004001645	CONDENSER ASSEMBLY	1
14.1	11224006000471	CONDENSER ASSEMBLY	1
14.2	11225506001814	CAPILLARY ASSEMBLY	1
15	11321009000033	TOP COVER	1
16	11321022000220	REAR GRILLE	1
17	11225504000976	SUCTION PIPE ASSEMBLY	1
18	11225505000947	DISCHARGE PIPE ASSEMBLY	1
19	11321025000048	PARTITION BOARD	1
20	11222004001034	MAIN CONTROLLER	1
20.1	11320058000081	CONTROL BOX COVER	1
20.2	11222031001142	MAIN CONTROL BOARD	1
20.3	11320057000101	CONTROL BOX	1
20.5	11330037000171	TERMINAL BOARD	1
20.6	11321015000068	E-PARTS BRACKET	1
21	11219005000203	ACCESSORY BAG	1
21.1	14618079000002	PUTTY	1
22	11320022000019	PLASTIC TIE	1
23	11329013000105	THERMAL SENSOR	1
24	11330034000008	REACTOR	1
999	11329013000105	DISCHARGE TEMP SENSOR	1

ESV12CRR-B4E
PNC 956004765 00

Model : ESV12CRR-B4I
 PNC : 956004741 00

Ex. Wiring
 (Indoor Unit)

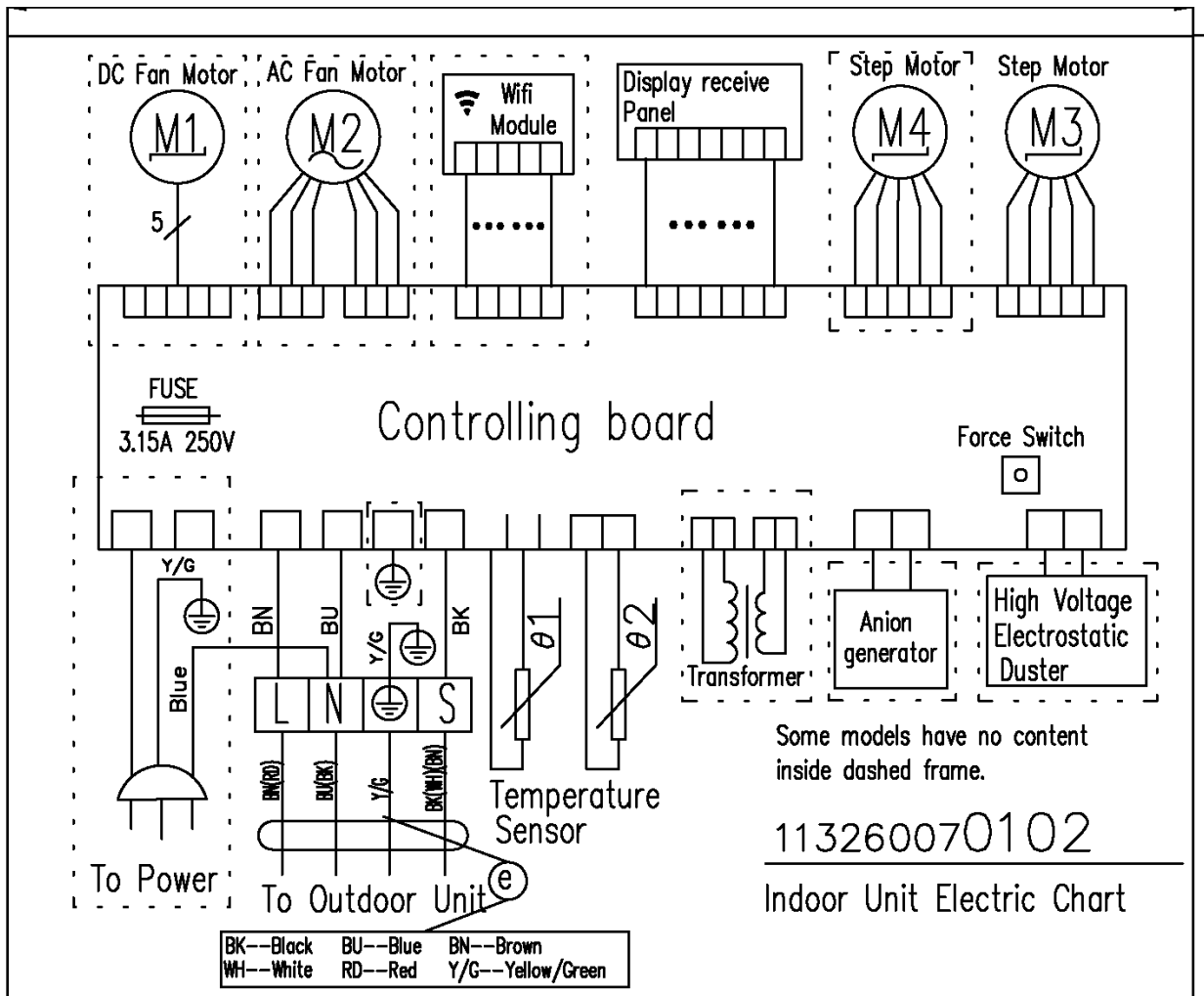

Model : ESV12CRR-B4E
 PNC : 956004765 00

Ex. Wiring
 (Outdoor Unit)

