



# Electrolux

## SPARE PARTS LIST

Split RAC  
(Cool only, Heat & Cool)  
4150



ITEM	PNC	ELC	BRAND	MODEL	MARKET
A	956004727	00	Electrolux	ESV09CRR-C7	VNE
A	956004751	00	Electrolux	ESV09CRR-C7I	VNE
A	956004775	00	Electrolux	ESV09CRR-C7E	VNE

### **SAFETY WARNING**

**Always turn off and unplug the machine before detaching any parts.**

When servicing machines, do not remove ANY detachable parts while the machine is powered. The reason is internal faults may cause shorts to components that are normally at low voltage presenting a shock hazard.

<p>Electrolux Thailand Co.,Ltd. 1910 Electrolux Building New Petchburi Rd. Bangkok Huaykwang Bangkok , 10310 Tel : +662 725 9000</p>	<p>Publication-No 200612</p>	<p>Split RAC (Cool only, Heat &amp; Cool)</p>
--	----------------------------------	---

Model : ESV09CRR-C7I  
PNC : 956004751 00

Ex. View Drawing  
(Indoor Unit)

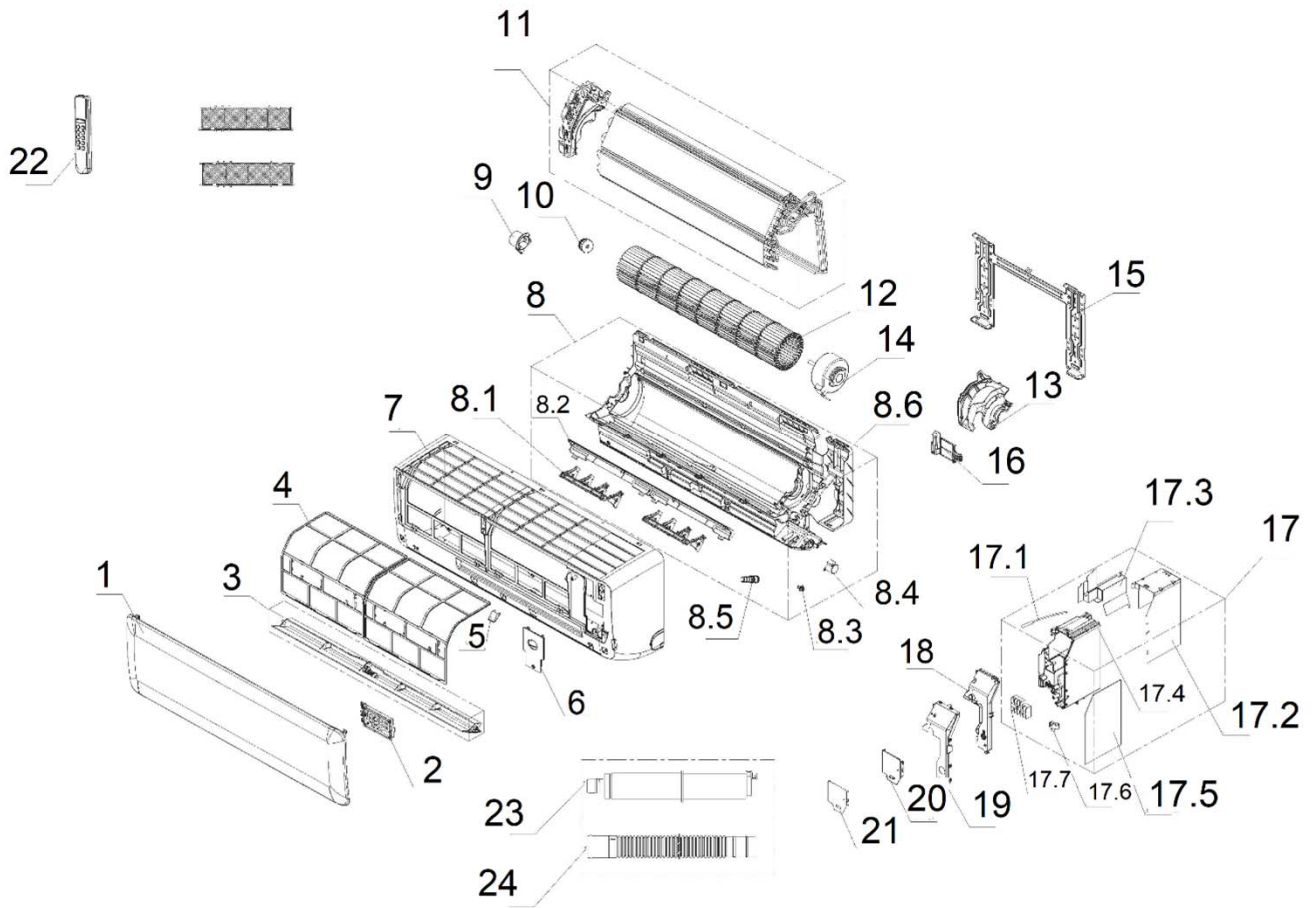

Item	PNC	ELC	Brand	Model	Market
A	956004751	00	Electrolux	ESV09CRR-C7I	VNE

Pos.	Part No.	Description
1	13220502007673	PANEL
2	11222014000650	DISPLAY BOARD
3	11320005000381	AIR LOUVER (HORIZONTAL)
4	11220508000146	FILTER
5	11320096000104	SCREW COVER
6	11320076000109	MEDIUM FRAME WIRING COVER
7	11320002000325	MEDIUM FRAME
8	11220500000214	CHASSIS ASSEMBLY
8.1	11320017000124	LEFT-RIGHT SWING BLADE
8.2	11320135000018	VOLUTE
8.3	11320079000016	STEP MOTOR SHAFT SLEEVE
8.4	11230002000086	AIR LOUVER STEP MOTOR
8.5	11333003000009	STOPPLE
8.6	11320001000241	CHASSIS
9	11320062000028	BEARING FIXED CHASSIS
10	11220551000003	BEARING ASSEMBLY
11	13224003001596	EVAPORATOR ASSEMBLY
12	11220513000065	CROSS FLOW FAN
13	11320052000044	MOTOR COVER
14	13330005000005	IDU FAN MOTOR
15	11221500000034	MOUNTING PLATE ASSEMBLY
16	11320084000013	PIPE CLAMP
17	13222002002527	MAIN CONTROLLER 09IDU CRR
17.1	11329013000103	TEMPERATURE SENSOR
17.2	11321020000033	CONTROLLER BOX SHEET-METAL A
17.3	11321020000034	CONTROLLER BOX SHEET-METAL B
17.4	11320057000082	CONTROL BOX
17.5	11222009003940	MAIN CONTROL BOARD
17.6	11320010000037	WIRE CLAMP
17.7	11330037000020	TERMINAL BOARD
18	11320058000067	CONTROL BOX COVER
19	11321020000035	CONTROLLER BOX METAL PLATE
20	11320111000005	GUARD OF ELECTRIC CONTROL BOX
21	11321020000036	COVER OF ELECTRIC CONTROL BOX
22	11222001000869	REMOTE CONTROLLER
23	11220506000002	WATER OUTLET ASSEMBLY
24	11320020000008	DRAIN PIPE

Model : ESV09CRR-C7E  
PNC : 956004775 00

Ex. View Drawing  
(Outdoor Unit)

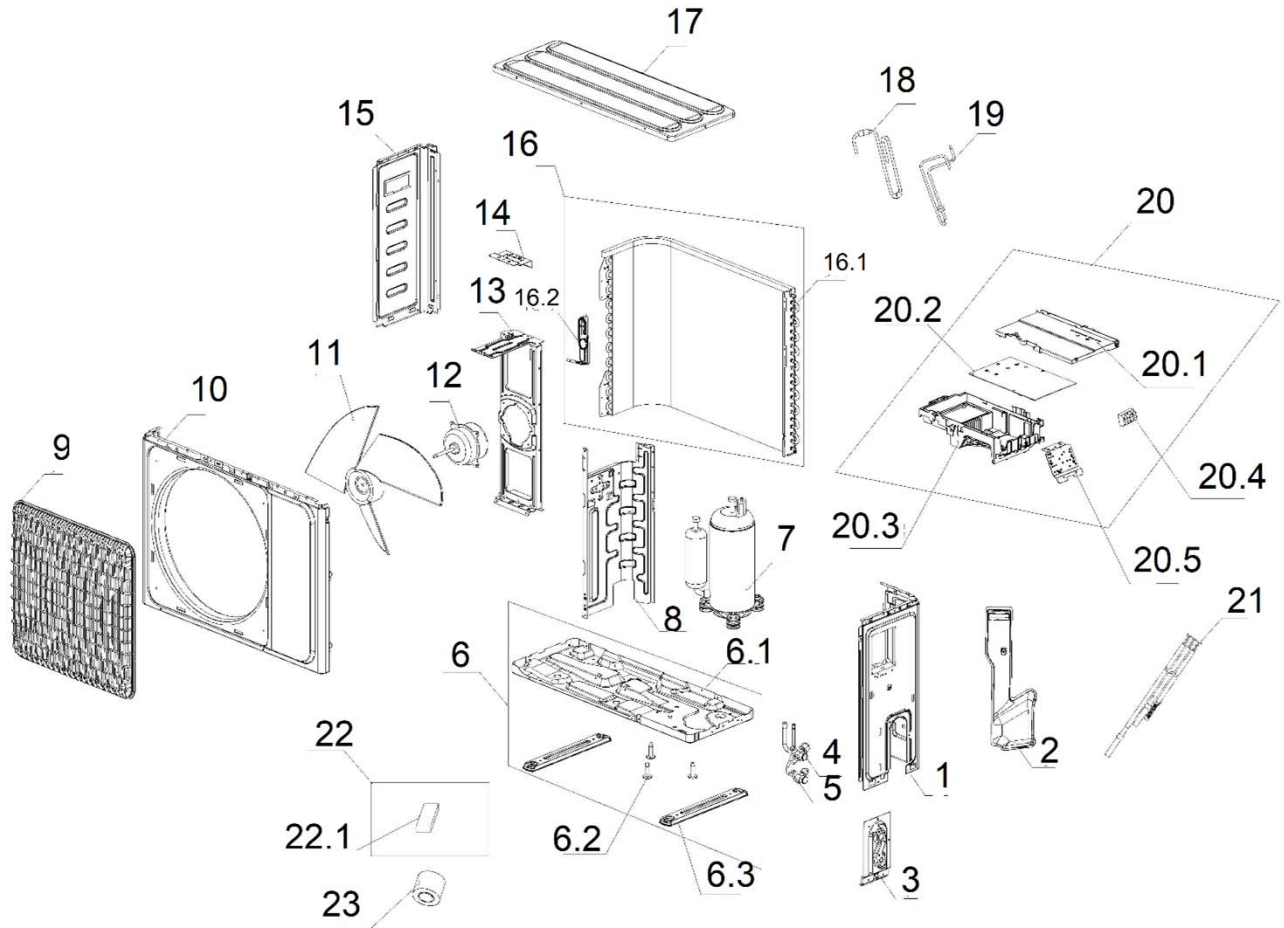

Item	PNC	ELC	Brand	Model	Market
A	956004775	00	Electrolux	ESV09CRR-C7E	VNE

Pos.	Part NO.	Description
1	11321157000014	RIGHT SIDE BOARD
2	11320101000039	E-PARTS COVER
3	11321031000027	VALVE PLATE
4	11325042000030	STOP VALVE (LIQUID)
5	11325042000015	STOP VALVE (GAS)
6	11221502000548	CHASSIS ASSEMBLY
6.1	11321014000133	CHASSIS
6.2	14731005000042	BELT SCREW
6.3	11321023000010	BASING FOOTING
7	11223003000384	COMPRESSOR
8	11321025000065	PARTITION BOARD
9	11320026000046	PANEL GRILLE
10	11321005000091	PANEL
11	11320009000049	AXIAL FLOW FAN
12	11230004000331	FAN MOTOR
13	11321002000035	MOTOR SUPPORT
14	11321029000046	CONDENSER BLOCK
15	11321006000151	LEFT SIDE BOARD
16	13224004002136	CONDENSER ASSEMBLY
16.1	11224006000486	CONDENSER ASSEMBLY
16.2	11225506001718	CAPILLARY ASSEMBLY
17	11321009000050	TOP COVER
18	11225504000972	SUCTION PIPE
19	11225505001076	DISCHARGE PIPE
20	13222004000303	MAIN CONTROLLER 09ODU,CRR
20.1	11320058000076	CONTROL BOX COVER
20.2	11222031001137	PCB
20.3	11320057000092	CONTROL BOX
20.4	11330037000171	TERMINAL BOARD
20.5	11321015000052	E-PARTS BRACKET
21	11329013000105	TEMPERATURE SENSOR
22	13219005000721	ACCESORY BAG
22.1	14618079000002	PUTTY
23	11320022000019	PLASTIC TAPE

Model : ESV09CRR-C7I  
 PNC : 956004751 00

Ex. Wiring  
 (Indoor Unit)

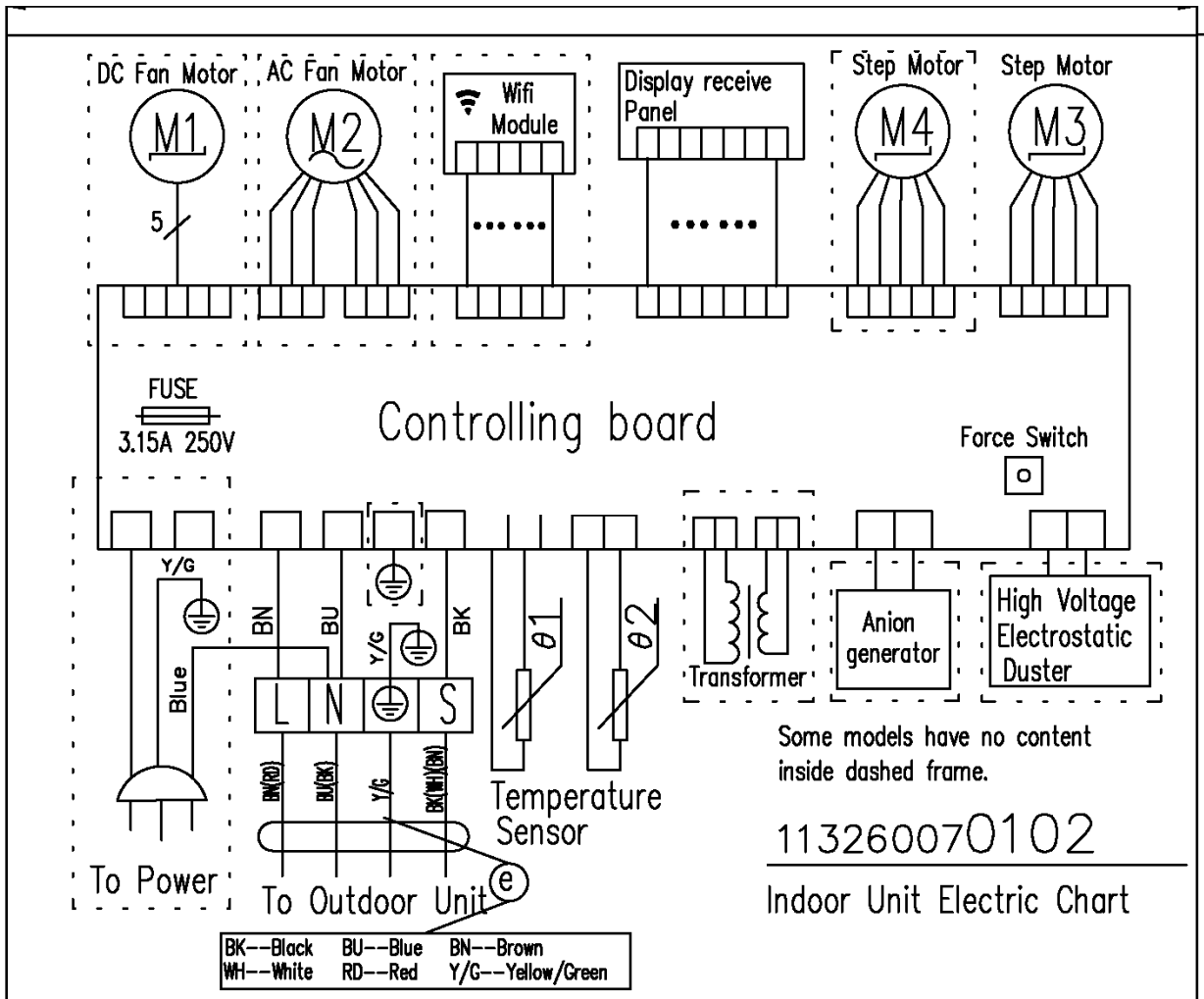

Model : ESV09CRR-C7E  
 PNC : 956004775 00

Ex. Wiring  
 (Outdoor Unit)

