



86

202



6

27

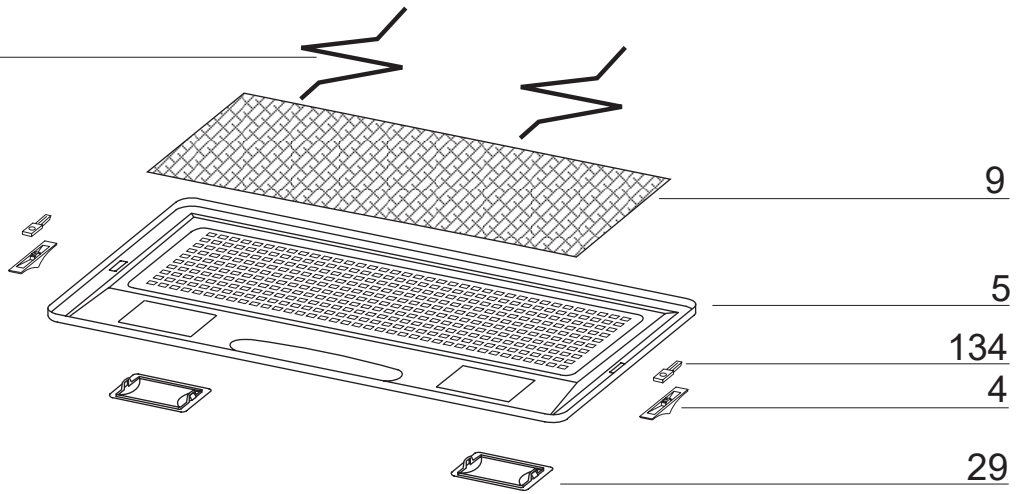

9

5

134

4

29