

485

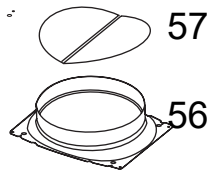

57

56

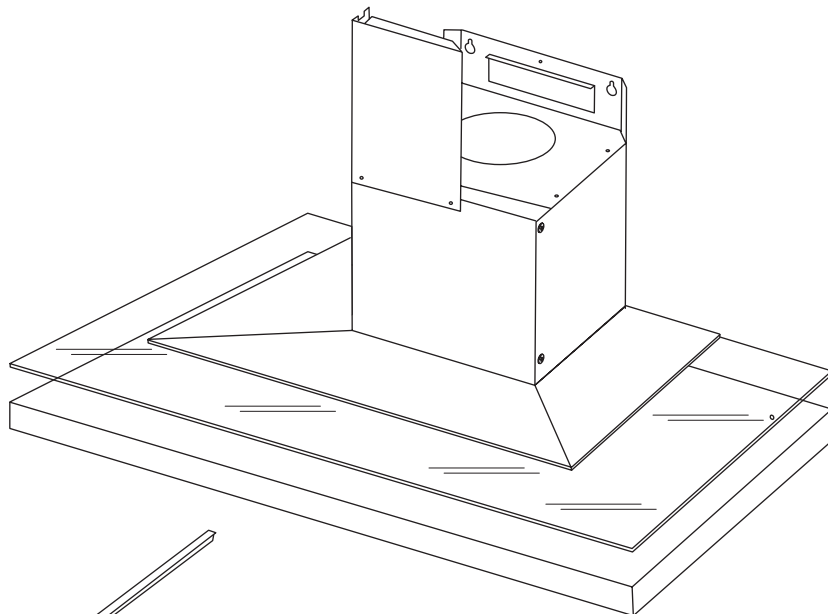

76

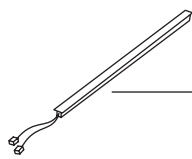
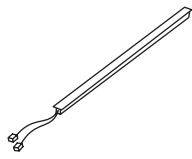

26

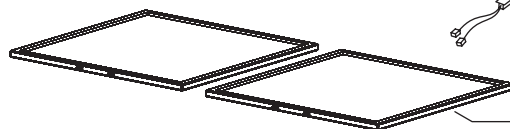

9