

162

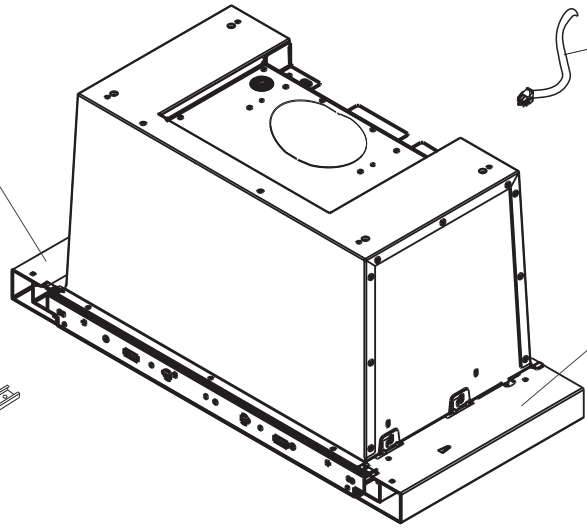

161

3

207

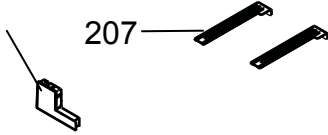

81

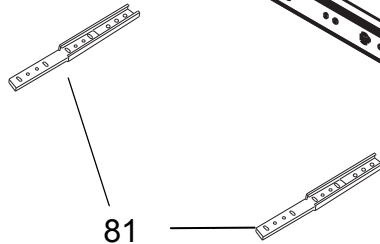

122

48

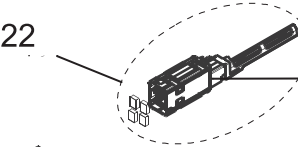

41

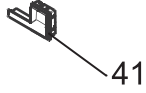

66

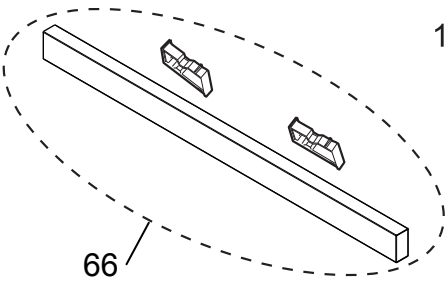

31 36

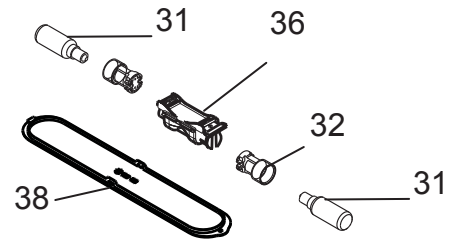

32

38

31

120



137

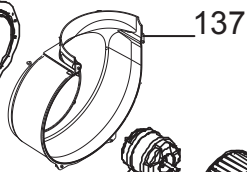

6

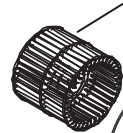

8



7



136

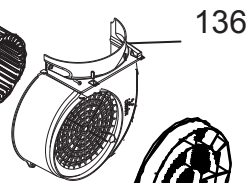

68



19

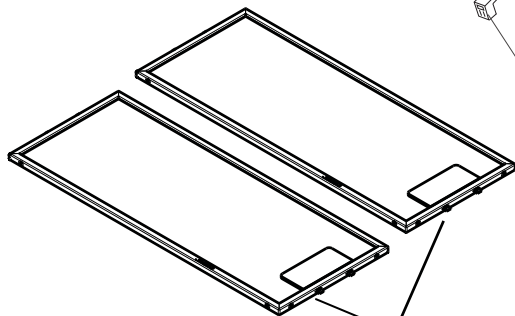

23



519