

2

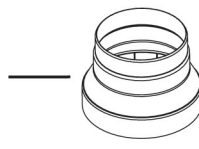

4

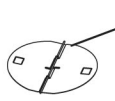

8

120



137

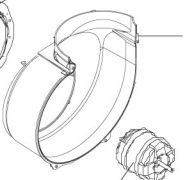

6

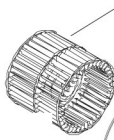

101

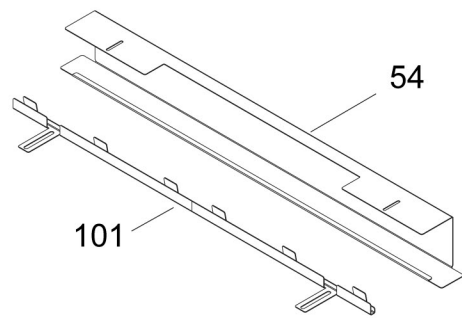

54



51

7

136

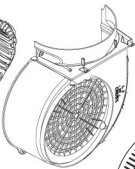

19



68



38

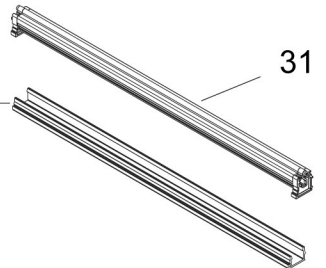

31

164

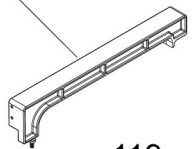

119

163

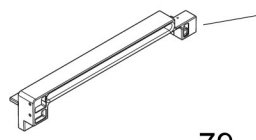

160



203

207

203

79



49

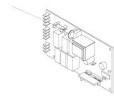

401



119

203

119

119

408



203

207

160

119



122



487

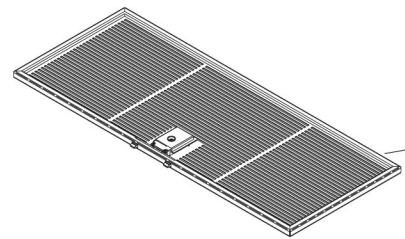
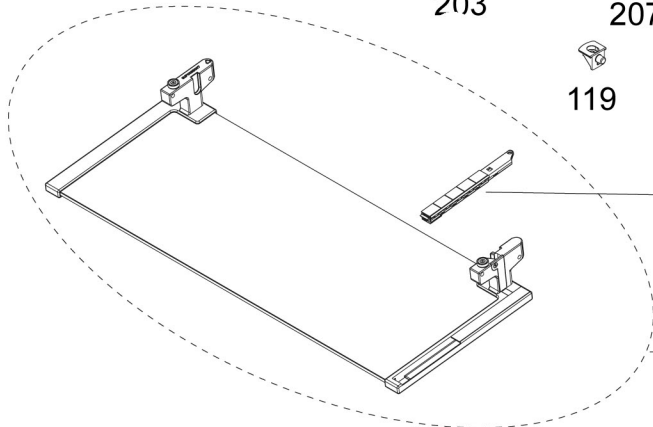

23

519

