

57

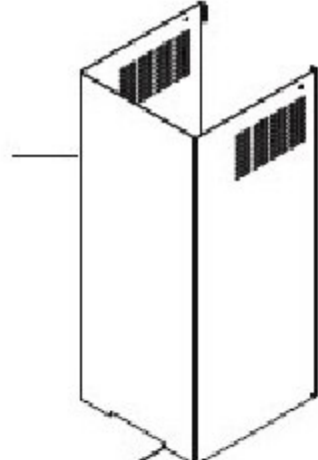

56

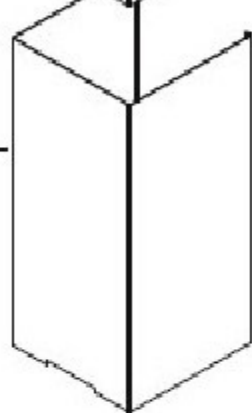

130

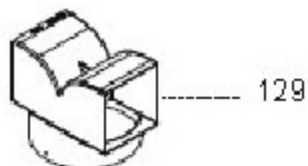

129



84



51

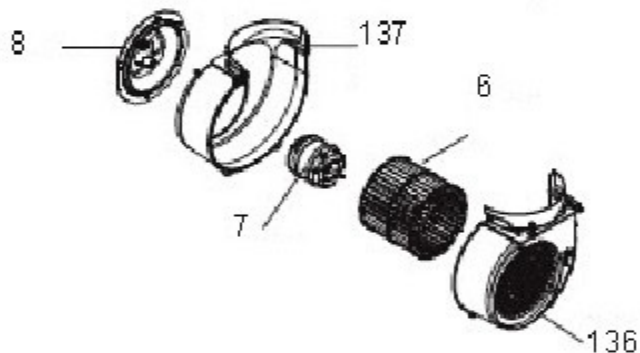

8

137

6

7

136



519



19

122

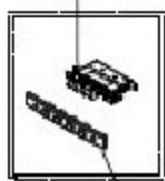

186



31



22

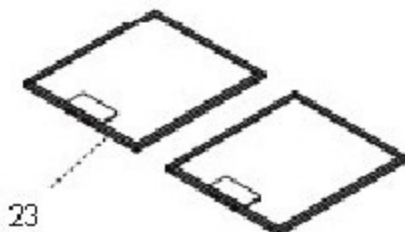

23