

129

130

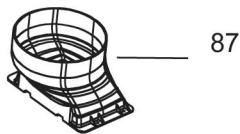

87

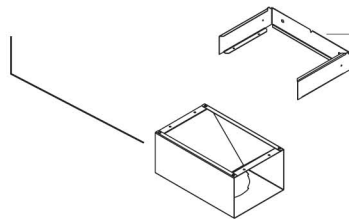

401

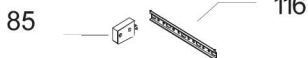

85

116

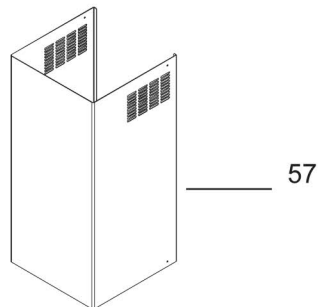

57



84



49

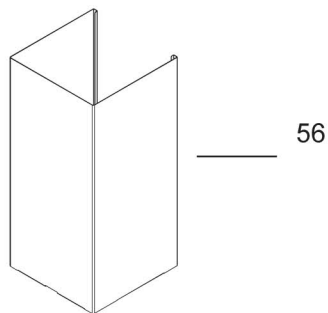

56

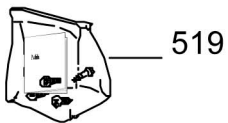

519

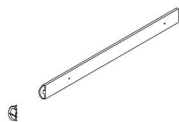

48

122

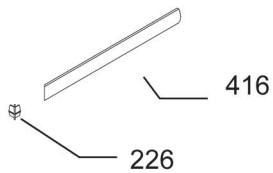
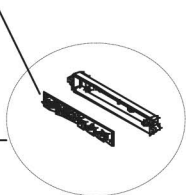

416

226

252



31

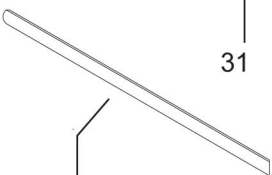

66

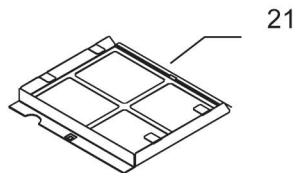

21

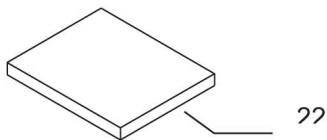

22

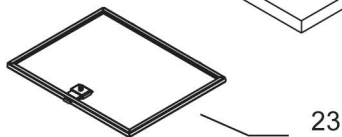

23