

530

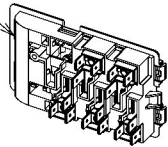

532A

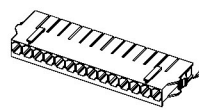

208A

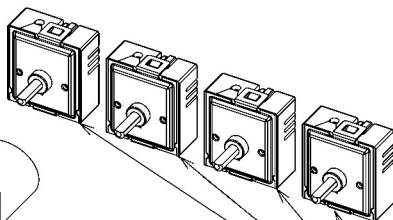
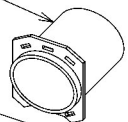

242



222S

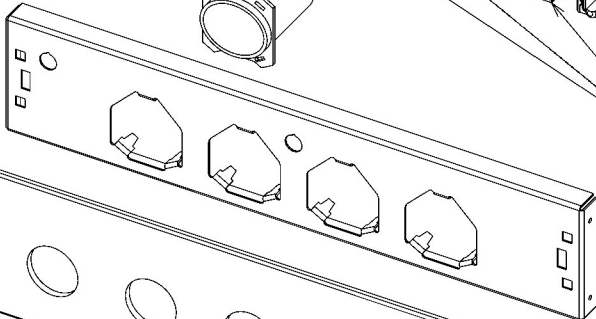

212

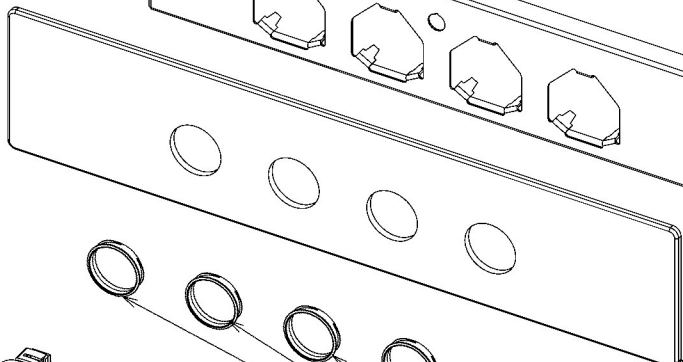

210

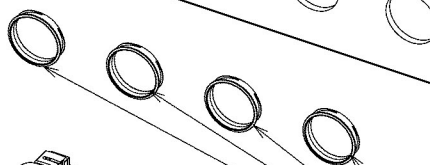

202

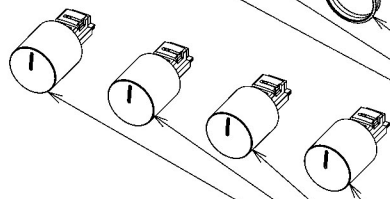

200