

530

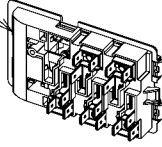

532A

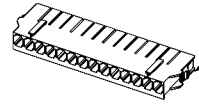

208A

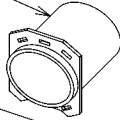

242



222D

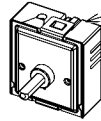

222S

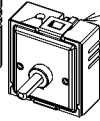

222D

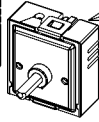

222S

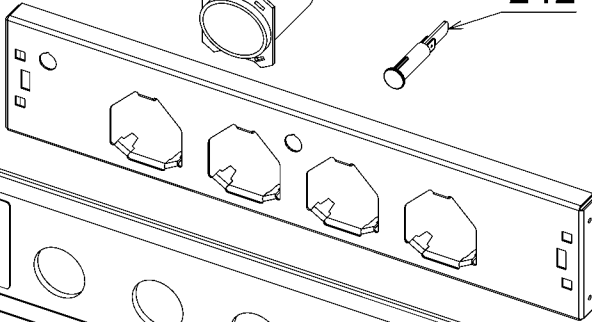
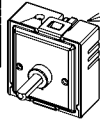

212

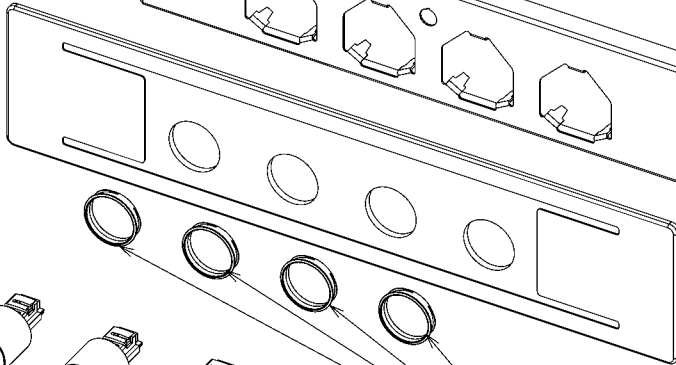

210

202

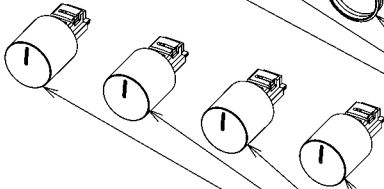

200