



# Electrolux

## SERVICE MANUAL

### Food Preservation

#### Document Revisions

Rev.	Date	Description	Author
00	01/2020	Document publication	Marcin Kobialka

FOR INTERNAL AND PARTNERS USE ONLY

© ELECTROLUX HOME PRODUCTS  
Technical Support

FRONT LOADED WASHING MACHINES

# FKWF75GGFW

EN

Publication number

599 83 49 - 33

Edition: 01/2020 - Rev. 00

# Table of Contents

1. Safety Precautions .....	4
2. Specifications .....	5
3. Control Panel and Acronyms .....	6
4. Test Mode .....	7
4.1. Autotest.....	7
5. Service Mode .....	9
5.1. Service Autotest.....	9
5.2. Failure Codes .....	10
6. Critical Torque Values .....	10
7. Disassembly and Assembly Instructions.....	11
7.1. Top Plate .....	11
7.2. Door .....	11
7.3. Spring Wire.....	12
7.4. Detergent Drawer .....	12
7.5. Control Panel.....	13
7.6. Electronic Card & Fuse .....	14
7.7. Front Panel .....	15
7.8 Dryer Card .....	16
7.9 Dryer Unit.....	16
7.10 Support Bracket .....	18
7.11 Detergent Drawer Housing.....	18
7.12 Power Cable Group and EMI Filter.....	18
7.13 Electronic Pressure Switch (EPS).....	19
7.14 Door Lock* .....	19
7.15 Drain Pump.....	20
7.16 Front Counterweight* .....	20
7.17 Heater .....	20
7.18 Tub Bellow Seal*.....	21
7.19 Transport Screw.....	21
7.20 Upper Counterweight* .....	21
7.21 Washing Group.....	22
7.22 Shock Absorber Pin .....	22
7.23 Driven Pulley.....	22
7.24 Driven Pulley.....	22
7.25 Motor .....	23
7.26 Tub .....	23
8. Component Specifications.....	24
8.1. Drain Pump.....	24
8.2. Heater .....	25
8.3. Washer NTC.....	26
8.4. Valve .....	27
8.5. Electronic Pressure Sensor (EPS)* .....	28
8.6. Motor .....	29
8.7. Door Lock* .....	30
8.8. Fan Group.....	31
8.9. Dryer Heater.....	32
8.10. Dryer NTC.....	33
8.11 Component Control on PCB.....	34
9. Wiring Diagram* .....	37
10. Troubleshooting .....	38

## About Content

This service bulletin is prepared for all products within D4 range. Therefore you may encounter information about some optional components that may not exist in your product. As this is a generic service bulletin covering all range, please ignore and skip extra/optional component information. Sections marked with asterisk (\*) sign contain information about optional components.

Information already exists in user manuals is not included in this service manual. Please refer to user manual of your product for basic installation, operating, maintenance and troubleshooting issues.

### Acronyms:

WM	:	Washing Machine
W&D	:	Washer & Dryer
WMCS	:	Washing Machine Customer Support
TJ	:	Twinjet
UI	:	User Interface
SI	:	Service Interface
A	:	Available
NA	:	Not Available

## 1. Safety Precautions



### Important:

This service information is designed for experienced repair technicians only and is not designed for use by the general public. It does not contain warnings or cautions to advise non-technical individuals of potential dangers in attempting to service a product. Products powered by electricity should be serviced or repaired only by experienced professional technicians. Any attempt to service or repair the product or products dealt with in this service information by anyone else could result in serious injury or death.



### Warning:

Before any disassembly/repair operation make sure appliance is unplugged water tap is closed and heating elements are cooled down. There is electrical shock, burning and flood risk.



### Warning:

Please replace whole cable group even in case there is any minor failure with cables / terminals / sockets. Never try to repair nor to solder cable group. It may cause smoke, ignition and there is major risk of electrical shock.



### Important:

Always use insulator gloves to prevent injury by metal edges or to prevent electrical shock during electrical tests.

Work with uniforms having long sleeves to protect your arms from metal edges.







Always use original spare parts. You may harm appliance, end user, environment or yourself using untested and unapproved 3rd party spare parts.

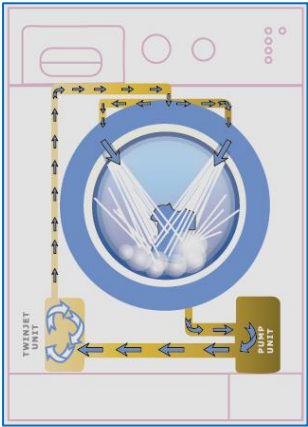

Use right tools to prevent any wear or damage to components during assembly/disassembly.

## 2. Specifications

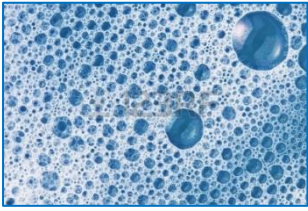
Here you will find descriptions of generic specifications for the range specified for this service manual. Please refer to product fiche and user manual for detailed technical specifications.

	<p><b>*Twinjet System:</b></p> <p>Twinjet system is designed to obtain a better washing performance by directly injecting water with detergent using a recirculation system and two nozzles connected to it. With twinjet system, water consumption is decreased by 30%, energy consumption is decreased by 10% and washing time is decreased by 15%</p> <p>Twinjet system is valid for all programs except spin and drain mode. The system does not function during Water inlet, heating, spinning, drain phases.</p> <p>Even with a large load of 8 kg. the washing machine will have the minimum energy consumption by the help of Twinjet system.</p> <p>Washing machines with Twinjet system are very environment-friendly by having maximum washing performance with minimum water consumption.</p>
	<p><b>Eco-Logic System:</b></p> <p>Half load detection system, thus using less water and power accordingly. This system is available for cotton programs only.</p>
	<p><b>Foam Protection System:</b></p> <p>Foam Protection System is a safety algorithm that interrupts normal program flow and reduces foam level by taking water and draining. This algorithm protects machine and environment avoiding over foaming inside tub in case any customer misuse such as detergent overdose or use of foamy cleaning agents.</p>
	<p><b>Overflow Protection System:</b></p> <p>Overflow protection is another safety algorithm in case of a flood risk. If there is more water in tub than expected by algorithm, it will start to the drain routine giving E04 failure code. For example this may happen in case of a valve failure and the machine constantly takes water. This algorithm will keep drain routine, keeps water leveled and protects environment and machine avoiding any flood risk.</p>
	<p><b>Unbalanced Load Detection and Control System:</b></p> <p>Unbalance Control System is another safety algorithm that protects the machine and environment avoiding machine movement due to vibration during spinning profile. The algorithm tries to balance load by a special balancing agitation, postponing spin profile till it is balanced. This avoids spinning while load is unbalanced and prevents any possible physical harm both to the appliance and to surroundings.</p>

### 3. Control Panel and Acronyms

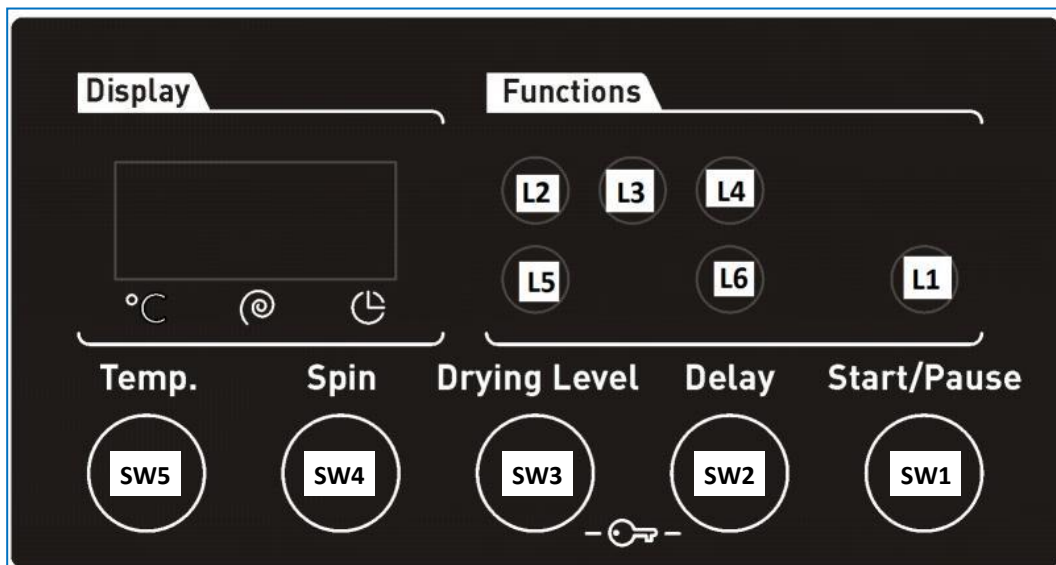
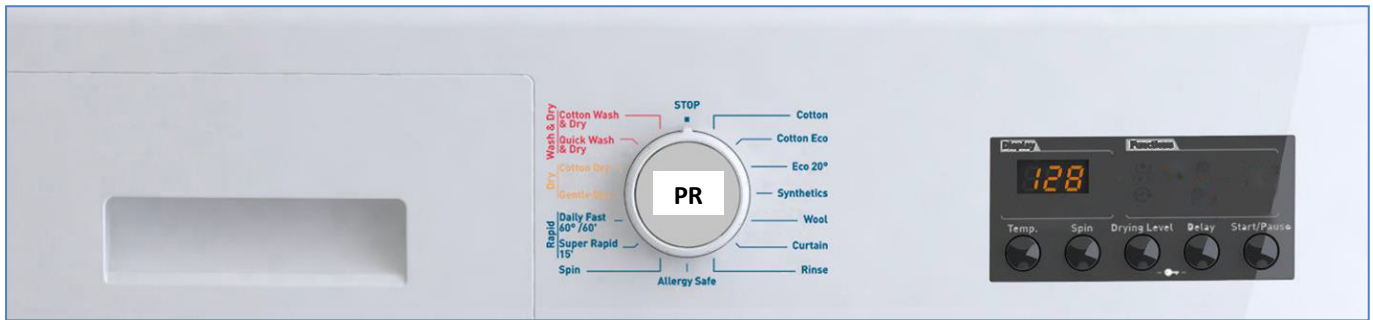

PR	Program selector 16 programs including off position
SW1	Switch 1, Start / Pause
SW2	Switch 2, Option 1 (Delay Timer)
SW3	Switch 3, Option 2 (Drying Level)
SW4	Switch 4, Spin Speed Selection
SW5	Switch 5, Temperature Selection
L1	LED 1, Start/Pause LED
L2	LED 2, Drying Level 1 LED
L3	LED 3, Drying Level 2 LED
L4	LED 4, Drying Level 3 LED
L5	LED 5, Drying Level Option LED
L6	LED 6, Delay Time LED

## 4. Test Mode

### 4.1. Autotest

1. Press and hold SW5.



2. While pressing SW5, turn PR to 1<sup>st</sup> position (Cotton). Wait 3 seconds and release SW5. During test "AU" is visualized on display.



3. When autotest is finished, END screen is visualized.



#### 4.1.1. Autotest Steps

Autotest follows a predefined flowchart in order. Unlike service autotest, autotest automatically skips to next step upon completing one. The steps of the test are as follows:

Step1:

The drain pump is checked.

Step2:

Motor ramps to max spin speed while valves are activated in order.

Step3:

Motor stops, both valves are activated simultaneously.

Step4:

The motor turns to right. Also, dryer valve is activated.

Step5:

The motor turns to left.

Step6:

Both valves are activated. (Water intake for heating)

Step7:

Washer NTC is checked.

Step8:

Washer Heater is checked.

Step9:

Dryer resistance I and I&II are checked.

Step10:

Dryer NTC is checked for 2sec.

Step11:

Fan is checked.

In case of no failure test ends after this step and "End" is displayed. In case of an error detection EXX and error definition will pop up on display. (where XX is the error number 1 to 10 )

Please see following autotest chart for details.

AUTOTEST	
Time in seconds (to be adjusted)	5 10 15 20 25 30 35 40 45 50 55 60 65 70 75 80 85 90 95 100
Entering autotest	Active from 0 to 10s
Changing power to 220 50Hz	Active from 10 to 15s
Main Voltage 50 Hz	Active from 15 to 100s
Door Lock Powered (Depends on door lock)	Active from 15 to 100s
Pump	Active from 20 to 100s
EPS measurement	Active from 20 to 25s
Motor Ramp to max spin (max. is 20 sec.)	Active from 20 to 40s
EV1 (flowrate dependent of washer)	Active from 20 to 45s
EV2 (flowrate dependent of washer)	Active from 25 to 45s
Dryer valve	Active from 45 to 55s
Time until motor is stopped (Depends on the motor stop time)	Active from 40 to 45s
Motor Preferred Run (Direction to Right)	Active from 45 to 55s
Motor Inverse Run (Direction to Left)	Active from 55 to 65s
EV1 + EV2 valves up to first level frequency (Depends on the water level)	Active from 65 to 75s
Washer NTC check	Active from 70 to 75s
Washer heater resistance	Active from 75 to 85s
Dryer resistance I	Active from 80 to 85s
Dryer resistance I + II	Active from 85 to 90s
Dryer NTC	Active from 90 to 95s
Fan	Active from 95 to 100s
End Visualization	Active from 95 to 100s

Washer Ntc detection : Software will detect NTC's resistance value and will check if the temperature is between  $5^{\circ}\text{C} < T_{\text{detected}} < 40^{\circ}\text{C}$ . If it is inside the range, heating step will be done. If temperature value is outside the range, then it means NTC is detecting the temperature in a wrong way and heating step will be skipped. Additionally if NTC connector disconnected it should shows NTC failure code(E05) on display.

EPS measurement: It checks the EPS and if it OK, it continues the autotest; if it is NOK then cancel the Autotest and go to the selection mode. Also if any frequency can not be detected, then it means there is problem with connexion or EPS, so it gives E10 which is EPS error and cancels the autotest & goes to the selection mode.

**Dryer Ntc detection** : Software will detect NTC's resistance value and will check if the temperature is between  $0^{\circ}\text{C} < T_{\text{detected}} < 50^{\circ}\text{C}$ . If it is inside the range, heating step will be done.



## 5. Service Mode

### 5.1. Service Autotest

1. Press and hold SW4.



2. While pressing SW4, turn PR to 1<sup>st</sup> position (Cotton). Wait 3 seconds and release SW4. Step 1 of service autotest will start. During test "SAU" is visualized on display. Please see details about steps in right column.



3. When autotest is finished, END screen is visualized.



#### 5.1.1. Service Autotest Steps

If you turn knob position to other program between 1<sup>st</sup> to 3<sup>rd</sup> it will skip current test and start the selected one. It is recommended not to skip any steps for a detailed checkup. Unlike autotest, service autotest starts next test step manually by rotating program selection knob.

##### Step1:

There will be a certain amount of water intake and then washer heater is activated for 8 minutes. Washer NTC values are checked in this period. In case of a washer heater/NTC failure, it pops up E05 error displaying "E05" on SW3.

At the end of heating, "SAU" visualization should make slow blink to indicate that the step is over. You can turn program knob to 2<sup>nd</sup> position to continue with step2.

\*During this step if EPS detects high water level, overflow algorithm is applied and E04 is released.

##### Step2:

Drain pump is activated; in case of a pump failure it pops up E03 error.

At the end of pump activation, "SAU" visualization should make slow blink to indicate that the step is over. You can turn program knob to 3<sup>rd</sup> position to continue with step3.

##### Step3:

Dryer Heater I and fan is activated. After 3 mins if there will be no temperature change ( $\Delta T < 10^{\circ}\text{C}$ ), it will release E14 failure.

If temperature increases accordingly ( $\Delta T > 10^{\circ}\text{C}$ ), "SAU" visualization should make slow blink to indicate that the step is over. You can turn program knob to 4<sup>th</sup> position to continue with step4.

##### Step4:

Dryer Heater II and fan is activated. After 3 mins if there will be no temperature change ( $\Delta T < 10^{\circ}\text{C}$ ), it will release E14 failure.

If temperature increases accordingly ( $\Delta T > 10^{\circ}\text{C}$ ), "SAU" visualization should make slow blink to indicate that the step is over. You can turn program knob to 5<sup>th</sup> position to continue with step5.

##### Step5:

Rapid 15' program algorithms is run to test all washing components, the only difference is error codes are displayed which normally are not displayed to end user.

If no error found in test program "SAU" visualization should make slow blink to indicate that the step is over. You can turn program knob to 6<sup>th</sup> position to continue with step6.

##### Step6:

A 5 mins drying program is run to test all drying components.

If case of no error service autotest ends and "End" is displayed.

\*If user changes the selector position, machine will do what is defined for the new selected position.

## 5.2. Failure Codes

Error Indication	Error Number	Indication in UI	Indication in SI
Door/Door Lock Failure	E01	A	A
Lack of water	E02	A	A
Pump failure	E03	A	A
Overflow	E04	A	A
NTC or Heater Failure	E05	NA	A
Motor Failure	E06	NA	A
Configuration Failure	E07	NA	A
Motor Triac Failure	E08	NA	A
Voltage Error	E09	A	A
Electronic Pressure Sensor	E10	NA	A
Dryer Board Connection Failure	E11	NA	A
Dryer Thermostat Failure	E14	NA	A
Twinjet Failure	E15	NA	A
Dryer Overheated Failure	E16	NA	A
Flowmeter Failure	E17	NA	A
Dryer NTC Failure	E18	NA	A



## 6. Critical Torque Values

	Assembly Location	Bolt/Nut/Screw	Torque Min. (Nm)	Torque Nom. (Nm)	Torque Max. (Nm)	Air Pressure Wrench Speed (rpm)
*	Transport Screw Assembly	Transport Screws	6.50	6.50	7.00	1000
*	Motor Assembly	Motor Screws	6.00	6.50	7.50	800
*	Front Concrete Weight - Front Tub Assembly	Front Counterweight Screws	14.00	14.50	14.75	600
*	Upper Counter Weight Assembly	Upper Counterweight Screws	25.00	27.50	30.00	440
*	Pulley – Drive Shaft – Washing Group Assembly	Pulley – Drive Shaft Assembly Bolt	39.50	40.00	40.50	440
*	Washer Heater Assembly	Heater Assembly Nut	3.85	4.00	4.00	970





The bolts/nuts above are important for product safety purposes. Please tighten screw, bolts and nuts according to the torque values given in table above.







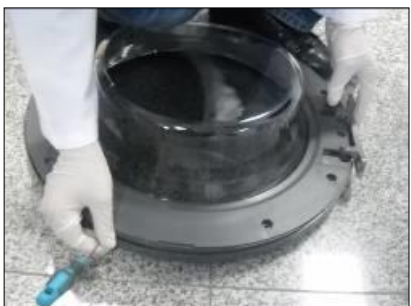

## 7. Disassembly and Assembly Instructions

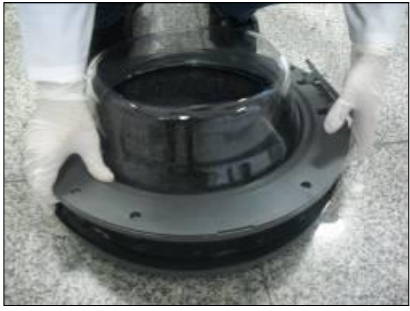
### 7.1. Top Plate

1		2	
Remove two screws that fix the top-plate at the back.		Push the top-plate back and pull it up.	

### 7.2. Door

1	  T25	2	
Remove two screws that fix the door. (by using T25 tool)		Pull the door up.	
3		4	
Remove screws that fix the door group.		Put the door outside plastic with helping screwdriver.	

5		6	
Remove the door inside plastic.		Remove six screws that fix the door hinge.	
7*		8*	
Remove the door handle.		Remove the door handle pin.	
<b>7.3. Spring Wire</b>			
1		2	
First, remove the spring wire fixing the tub bellows seal by using the small size screw driver. Pull the tub bellows seal.		Remove the tub bellows seal-body fixing spring.	
<b>7.4. Detergent Drawer</b>			
1		2	
Gently pull the detergent drawer.		While pressing siphon cover keep pulling drawer to remove it.	

## 7.5. Control Panel

1







Remove the screw which fixes the control panel to the front panel.



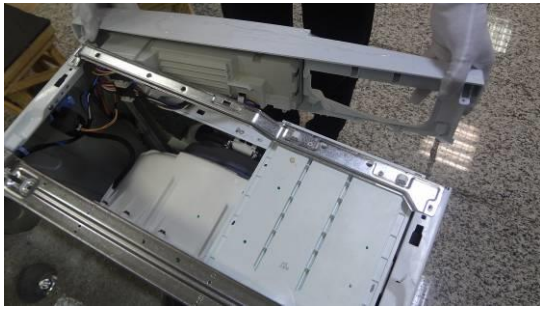
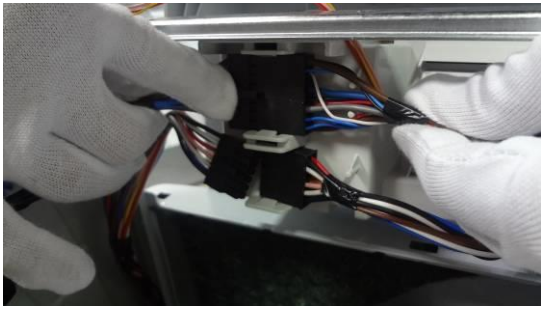
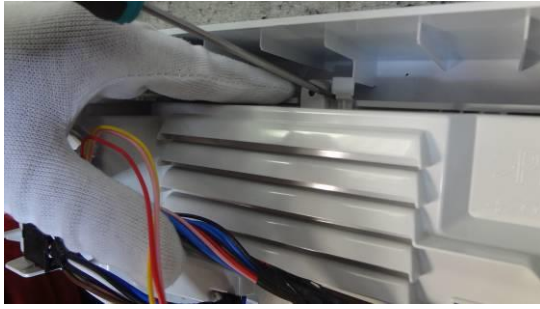
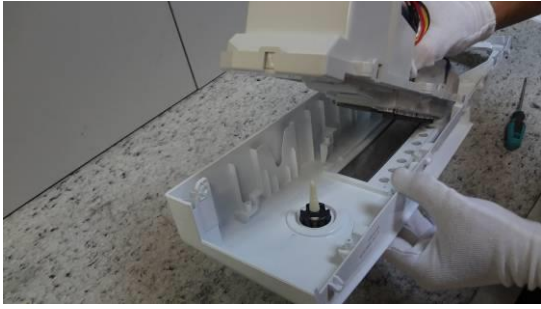





2





Remove two screws fixing control panel.



<p>3</p> 	<p>4</p> 
<p>Pull the control panel out.</p>	<p>Remove connectors.</p>
<p>5</p> 	<p>6</p> 
<p>Remove electronic card cover as it is shown in the pictures by using small screw driver.</p>	<p>Remove the PCB card box from the control panel.</p>
<p><b>7.6. Electronic Card &amp; Fuse</b></p>	
<p>1</p> 	<p>2</p> 
<p>Remove PCB box using a small screw driver.</p>	
<p>3</p> 	<p>4</p> 
<p>Unplug display card connector.</p>	<p>Open fuse box and remove the fuse.</p>

## 7.7. Front Panel

1		2	
Remove the screw fixing the front panel at the bottom		Remove two screws fixing the door lock	
3		4	
		Remove the tub bellows seal.	
5		6	
Remove two screws fixing front panel to body		Remove the screw fixing twinjet elbow	
7		8	
Pull front panel up		Remove front panel	

<p>9</p>		<p>10</p>	
<p>Remove the screw that fixes the pump filter cover.</p>		<p>Release the holder of the pump filter cover.</p>	

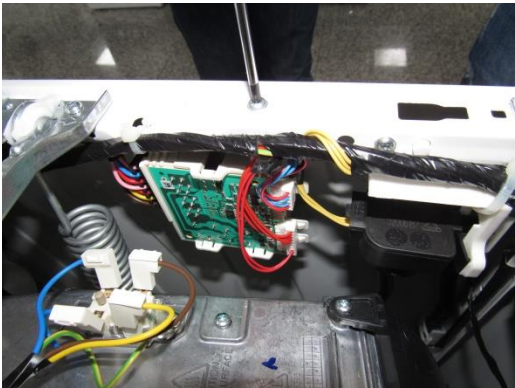

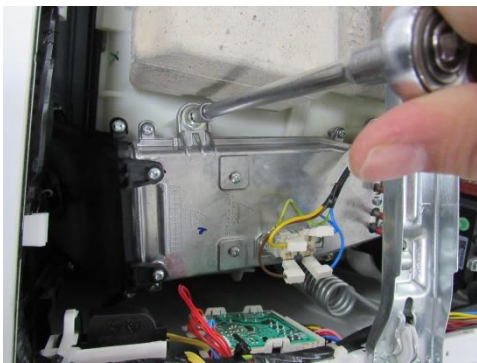
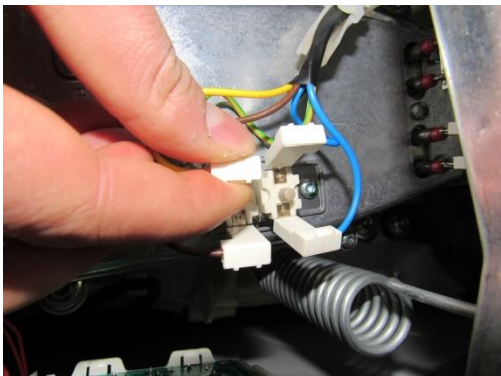

### 7.8 Dryer Card

<p>1</p>		<p>2</p>	
<p>Remove the screws that fixes the dryer card</p>		<p>Remove the sockets.</p>	

### 7.9 Dryer Unit

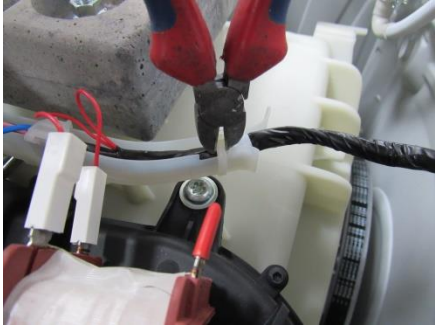
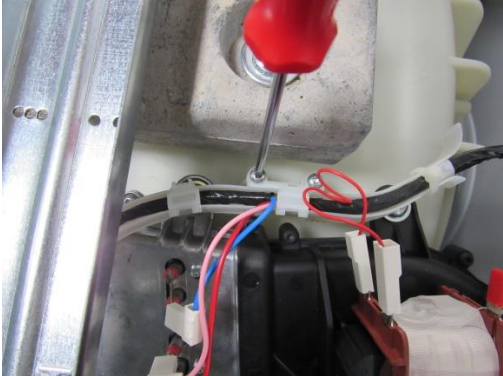
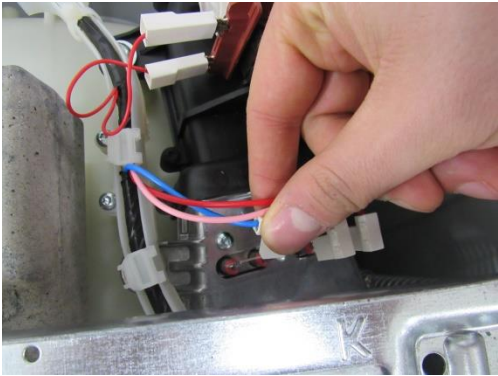
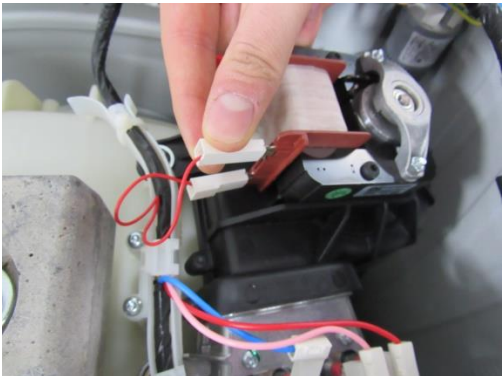
<p>1</p>		<p>2</p>	
<p>Remove the screws that fixes the heater unit of the dryer</p>		<p>Remove the sockets of the heater unit</p>	





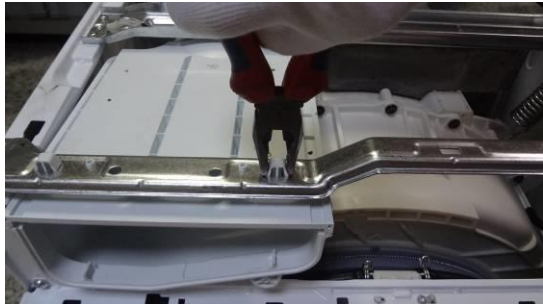

2		3	
Remove the screws that fix the fan group.		Release the cable group by cutting the cable connection.	
4		5	
Remove the Cable group of the dryer unit		Remove the sockets of the heater group	
6		7	
Remove the sockets of the fan group.		Remove the screws that fix the fan group.	
8		9	
Cut the connection plastic of the dryer unit.		Cut the cable connection of the dryer NTC and remove the sockets.	



### 7.10 Support Bracket



1		2	
Remove two screws fixing the body group on the upper part		Remove two clips fixing detergent drawer housing to upper support bracket	

### 7.11 Detergent Drawer Housing



1		2	
Remove the tub bellow hose by releasing the holder extensions of bellow hose		Unplug connectors from feed valve	
3		4	
Slightly turn the feed valve counter-clockwise to remove		Remove the detergent drawer housing assembly	

### 7.12 Power Cable Group and EMI Filter

1		2	
Remove the five connectors that is connected to the EMI filter		Remove two screws fixing EMI filter.	

3		4	
Pull the power cable group up		Remove EMI filter	





**7.13 Electronic Pressure Switch (EPS)**

1		2	
Unplug EPS connector		Pull EPS up	
3			
Remove clamp from EPS hose			



**7.14 Door Lock\***

1			
Unplug door lock connector			



### 7.15 Drain Pump







1		2	
Remove clamp holding drain hose by using a plier		Remove clamp fixing tub outlet hose	
3		4	
Unplug drain pump connector		Remove screws holding drain pump	







### 7.16 Front Counterweight\*



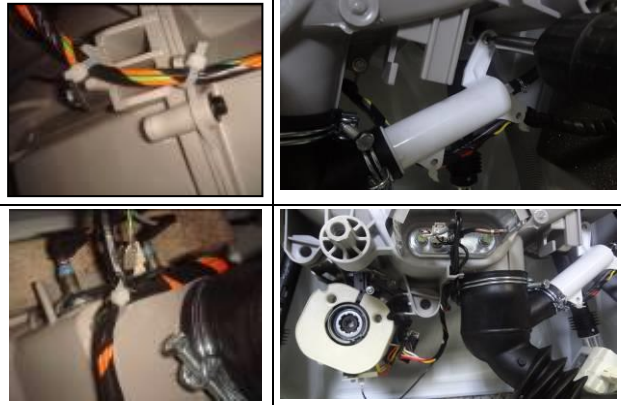





1		2	
Remove three screws on the front counterweight. (Wrench size 13 mm)		Gently pull counterweight out	

### 7.17 Heater

1		2	
Unplug heater connectors		Remove nut (8 mm) fixing the heater	

3		
Pull heater out gently holding both sides.		
<b>7.18 Tub Bellow Seal*</b>		
1		2
Remove the tub gasket clip by using small screwdriver		
		Hold the tub bellows seal and gasket-body fixing spring together, and pull them out.
<b>7.19 Transport Screw</b>		
1		2
Remove four transport screws		
		Hold the transport screw and pull it out.
<b>7.20 Upper Counterweight*</b>		
1		2
Remove two screws fixing the upper counterweight by using box wrench size 13 mm		
		Hold and carry upper-counterweight out.

7.21 Washing Group	
<p>1</p> 	<p>2</p> 
<p>Unplug motor connectors</p>	<p>Cut all the cable ties which fix cable group</p>
<p>3</p> 	<p>4</p> 
<p>Remove the screws fixing hanger bracket</p>	<p>Remove the washing group carrying it out through front side</p>
7.22 Shock Absorber Pin	
<p>1</p> 	<p>1</p> 
<p>Remove shock absorber pins squeezing the ratchet by a pliers</p>	<p>Remove the belt rotating the driven pulley</p>
7.24 Driven Pulley	
<p>1</p> 	<p>1</p> 
<p>Remove the bolt at the center of pulley by tucking a wooden bar avoids rotation</p>	<p>Remove pulley</p>

7.25 Motor	
1	
	Remove two screws holding motor by using box wrench
2	
	Pull motor up
7.26 Tub	
1	
	Remove tub inlet bellow hose loosening the clamp squeezing it by using a pliers
2	
	Remove screw holding EPS reservoir
3	
	Remove tub outlet bellowed hose loosening screwed-clamp
4	
	Remove 19 screws around tub using box wrench size 8 mm
5	
	Remove front tub
6	
	Remove drum

## 8. Component Specifications

### 8.1. Drain Pump

Drain pump is both a mechanical and electrical component which is used to drain water inside the washing machine. It has an synchronous motor inside. For better performance maintenance, pump filter should be cleaned regularly.



Drain pump

#### *Technical features*

Nominal voltage	220-240 V	Resistor (coil)	125 $\Omega$ ( $\pm 5\%$ )
Nominal current	0.28 A ( $\pm 10\%$ )	Water flow	17 L/min(to 1 m height)
Nominal power	30 W ( $\pm 20\%$ )	Thermal protector	YES
Frequency	50 Hz		

#### *Testing component*

Check the resistance value on the component with multimeter as shown below.  
Resistance value should be between 125  $\Omega$  ( $\pm 5\%$ )





## 8.2. Heater

Heating element (Resistance) is a component which is designed to regulate temperature of water inside the drum. It has three connections: Phase, notral and ground connections.



Resistance

### Technical features

Heater type	Tubular heating element with NTC – sensor	Nominal power	2000 W $\pm$ 5%
Nominal voltage	230 V	Resistance	26.4 $\Omega$ $\pm$ 5%
		Thermal fuse	2 sided

### Testing component

Check the resistance value on the component with multimeter as shown below.  
Resistance value should be between 26.4  $\Omega$   $\pm$ 5%



### 8.3. Washer NTC

The component which sends signals to PCB about the water temperature inside the tub. The resistance value of the NTC decreases as the temperature increases.



NTC

#### Technical features

Temp. (°C)	R min (kΩ)	R max (kΩ)
-10	54.9	62.6
-5	43.0	48.6
0	33.9	38.1
5	27.0	30.1
10	21.6	23.9
15	17.4	19.1
20	14.1	15.4
25	11.5	12.5
30	9.4	10.2
35	7.8	8.3
40	6.4	6.9
45	5.4	5.7

Temp. (°C)	R min (kΩ)	R max (kΩ)
50	4.5	4.7
55	3.8	3.9
60	3.2	3.3
65	2.7	2.8
70	2.3	2.4
75	1.9	2.0
80	1.7	1.8
85	1.4	1.5
90	1.2	1.3
95	1.1	1.1
100	0.9	1.0

NTC Resistance vs. NTC Temperature

#### Testing component

Check the resistance value on the component with multimeter as shown below.



## 8.4. Valve

Valve is an electrical and mechanical component which is designed to take water from network system into the washing machine. It is operated by PCB card.

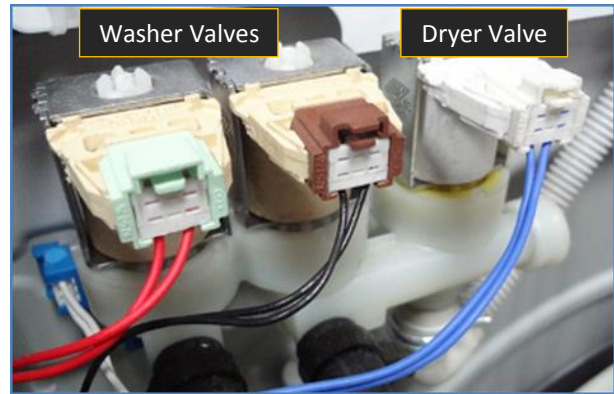

Valves

### Technical features

Nominal voltage 220-240 V  
Frequency 50-60 Hz

Flow rate (washer valves) 7 L/min ( $\pm 15\%$ )  
Flow rate (dryer valve) 1.2 L/min ( $\pm 15\%$ )  
Operating water pressure 1-10 bar

### Testing component

Check the resistance value on the component with multimeter as shown below. Washer valves' water flow rate should be 7 L/min  $\pm 15\%$ . Dryer valve's water flow rate should be 1.2 L/min  $\pm 15\%$ . Washer valves' coil resistance values should be  $3750\Omega \pm 10\%$ . Dryer valve's coil resistance value should be  $5190\Omega \pm 10\%$ .



### 8.5. Electronic Pressure Sensor (EPS)\*

Electromagnetic field occurs due to movement of pressurized membrane. The coil moves vertically by nucleus due to electromagnetic field. The water level is regulated according to the frequency changes of the coil by electronic card.

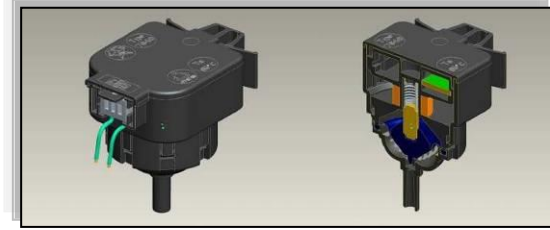

EPS

#### ***Testing component***

1. Make sure there are no laundry in washing machine, tap is connected and opened, power cord is plugged. Put no detergent in drawer.
2. Bring program knob to position 1 (Cotton 90°C program)
3. Press start button.
4. Wait for water intake step to finish. You can recognise it by listening the water sound or slightly opening and observing detergent drawer.
5. As soon as water intake is over turn program knob to position 0 (Off position)
6. Check water level from door glass. The water level should be just below door glass as seen in the picture below: (There is a %10 tolerance with this level) 32013066



## 8.6. Motor

The washing machine has an asynchronous motor. It is controlled by the PCB. It is essential to check the motor for correct diagnosis and quick servicing. In the below picture, socket points on the motor is shown to measure with multimeter.

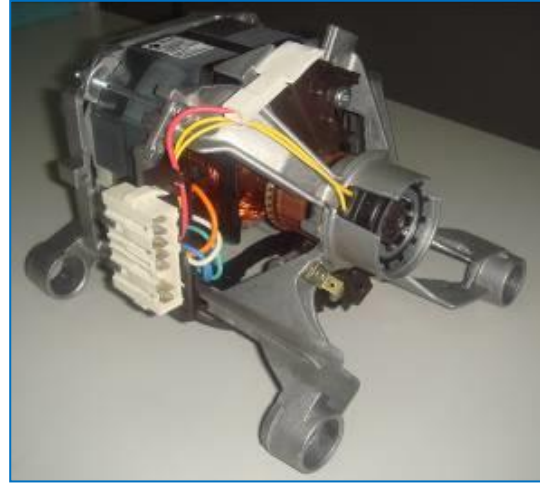

Motor

### *Motor socket terminals*

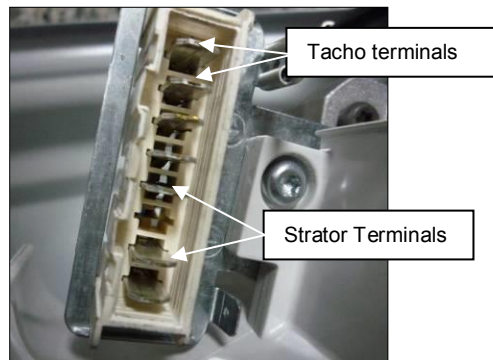

MOTOR CODE	BRAND	STATOR (FULL) $\Omega$	TACHO $\Omega$	STATOR (HALF) $\Omega$	TEMP.
32013066	ANAIMEP	1.20 $\pm$ 7%	180 $\pm$ 7%	0.55 $\pm$ 7%	20 °C

### 8.7. Door Lock\*

Door lock is activated at the beginning of the program in order to prevent the door from opening. It can be unlocked between 45 seconds to 85 seconds after the program end. This time delay is caused by the PTC which is assembled in the door lock.

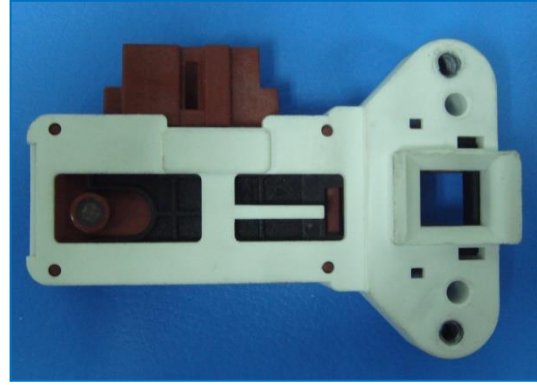

Door lock

#### *Technical features*

Nominal voltage      250 V

#### *Testing component*

Check the resistance value on the component with multi-meter as shown in below figures. Resistance value should be  $1000\Omega \pm 50\%$  at  $20\text{ }^\circ\text{C}$ .



## 8.8. Fan Group

Air pump component for drying cycle. Pumps dry cold air from condenser to dryer heater.



Fan group

### Technical features

Nominal voltage	230 V	Resistance @ 20°C	82.7Ω ±3Ω
Frequency	50 Hz	Motor speed	1300 RPM
Rated Power	34 W	Air Flow Rate	70 m <sup>3</sup> /h

### Testing component

Check the resistance value on the component with multi-meter as shown in below figures. Resistance value should be 82.7Ω ±3Ω at 20 °C.



## 8.9. Dryer Heater

Air heater unit consist of two separate resistance with nickel diffusion technology.



Dryer Heater

### Technical features

Nominal voltage	230 V	Resistance @ 20°C	65.5 – 72.6 Ω
Rated power (Heater I)	750 W		
Rated power (Heater II)	750 W		

### Testing component

Check the resistance value on the component with multi-meter as shown in below figures. Resistance value should be in 65.5 – 72.6 Ω range.





## 8.10. Dryer NTC

The component which sends signals to PCB about the flowing air temperature just after dryer heater. The resistance value of the NTC decreases as the temperature increases.



Dryer NTC

### Technical features

Temp. (°C)	R min (kΩ)	R max (kΩ)
25	19.40	20.60
30	15.56	16.67
40	10.19	11.10
50	6.82	7.54
60	4.65	5.23
70	3.25	3.70
80	2.32	2.68
90	1.69	1.97
100	1.24	1.47

Temp. (°C)	R min (kΩ)	R max (kΩ)
110	0.93	1.11
120	0.70	0.85
130	0.54	0.66
140	0.42	0.52
150	0.33	0.41
160	0.26	0.32
170	0.21	0.25
180	0.17	0.20

NTC Resistance vs. NTC Temperature

### Testing component

Check the resistance value on the component with multi-meter as shown in below figures.

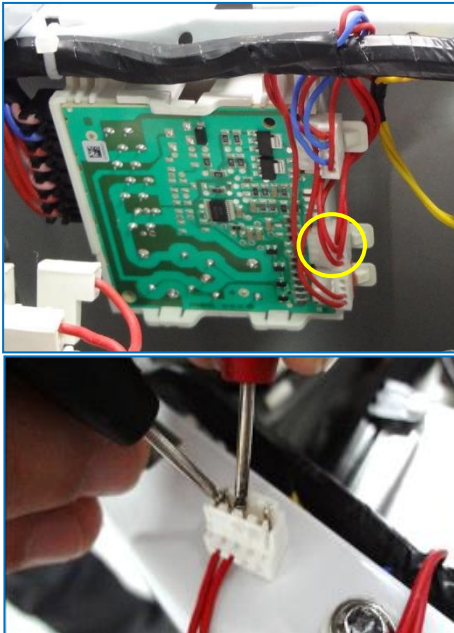

## 8.11 Component Control on PCB

### Sockets on the PCB

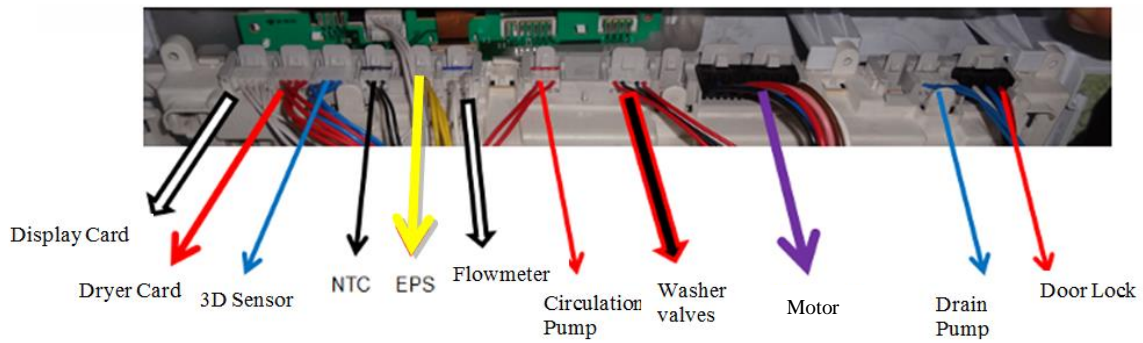

### Sockets on the Dryer Board



### 8.11.1 Washer NTC

NTC resistance values are checked (black cables) as shown. Refer to the relevant table for the NTC resistance values..

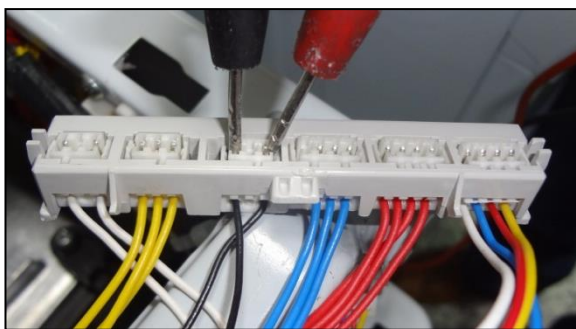

### 8.11.2 Circulation Pump

Resistance values are checked (red cables) as shown.



### 8.11.3 Washer Valves

Valve resistance value is checked with a multimeter as shown.  
Washer valves resistance values :  $3750 \Omega \pm 10\%$

Pre-Wash Valve:  
Check the red cables

Main Wash Valve:  
Check the black cables

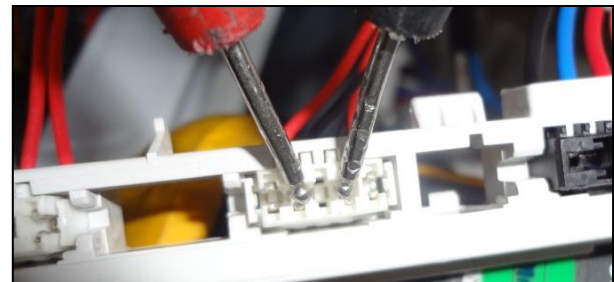
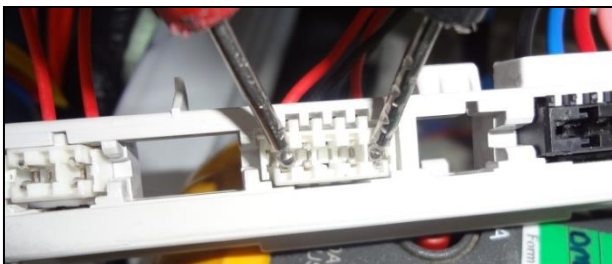

### 8.11.4 Drain Pump

Check the blue-blue cables  
 Drain Pump resistance value: 125 - 140  $\Omega$



### 8.11.5 Door Lock

Resistance value is checked with a multimeter as shown.

Check the white and blue cables

Resistance values 240 $\Omega$   $\pm$ 20% (25  $^{\circ}$ C)



### 8.11.6 Dryer NTC

Component Control :  
 Check the socket at the bottom of the dryer board as shown.



T $^{\circ}$ C	R(K $\Omega$ ) MIN	R(K $\Omega$ ) CEN	R(K $\Omega$ ) MAX
25	19.40	20.00	20.60
30	15.56	16.11	16.67
40	10.19	10.64	11.10
50	6.819	7.176	7.544
60	4.653	4.933	5.225
70	3.246	3.466	3.697
80	2.322	2.495	2.679
90	1.688	1.825	1.972
100	1.244	1.353	1.471
110	0.9296	1.017	1.112
120	0.7042	0.7747	0.8516
130	0.5404	0.5976	0.6603
140	0.4198	0.4665	0.5180
150	0.3296	0.3681	0.4107
160	0.2614	0.2932	0.3286
170	0.2092	0.2357	0.2653
180	0.1690	0.1912	0.2161

## 9. Wiring Diagram\*

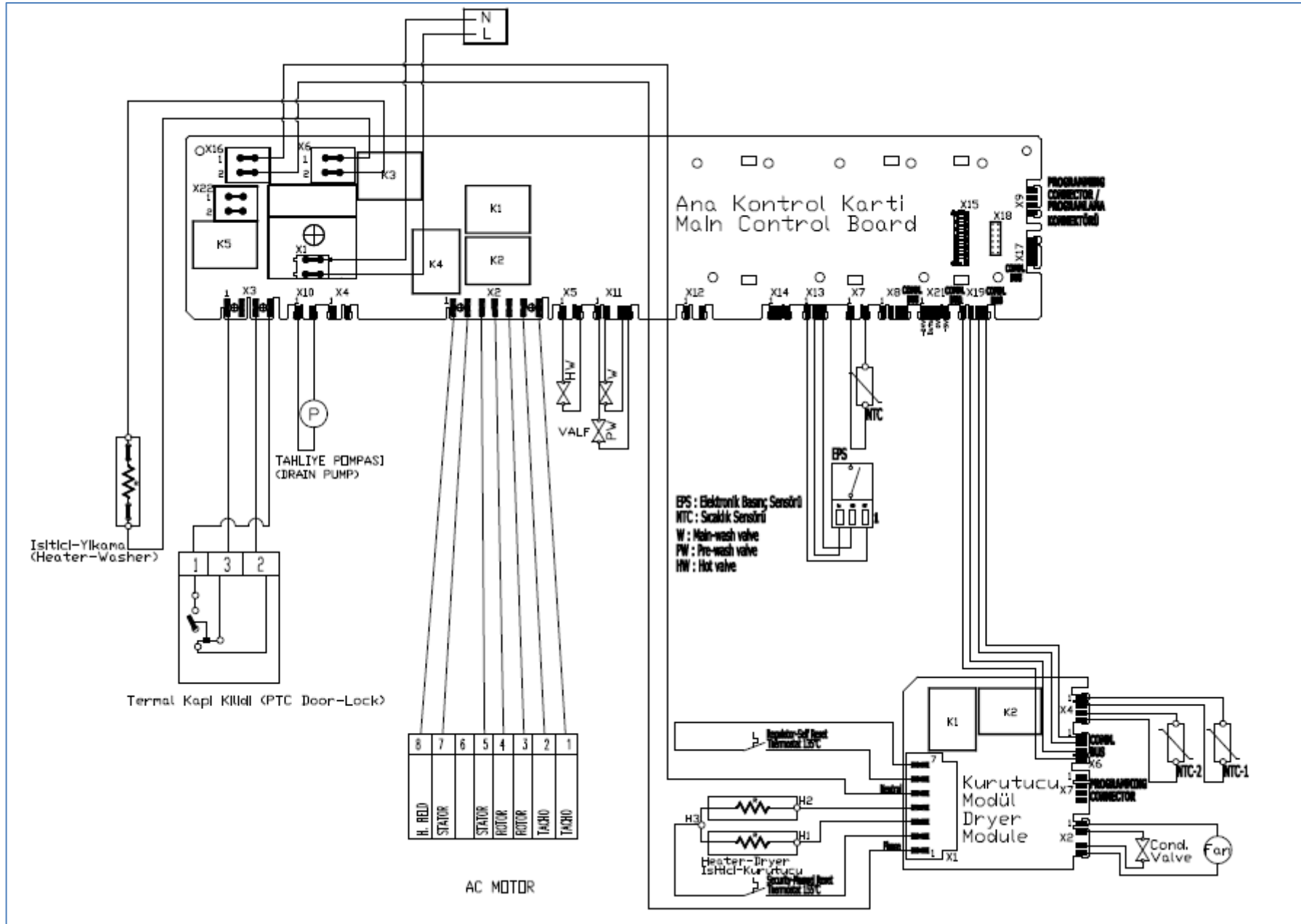

# 10. Troubleshooting

Please apply basic troubleshooting steps described in user manual. If you can not find a solution you should run service autotest and complete all steps. In case of an error encounter please follow the instructions through flowchart related with the error.

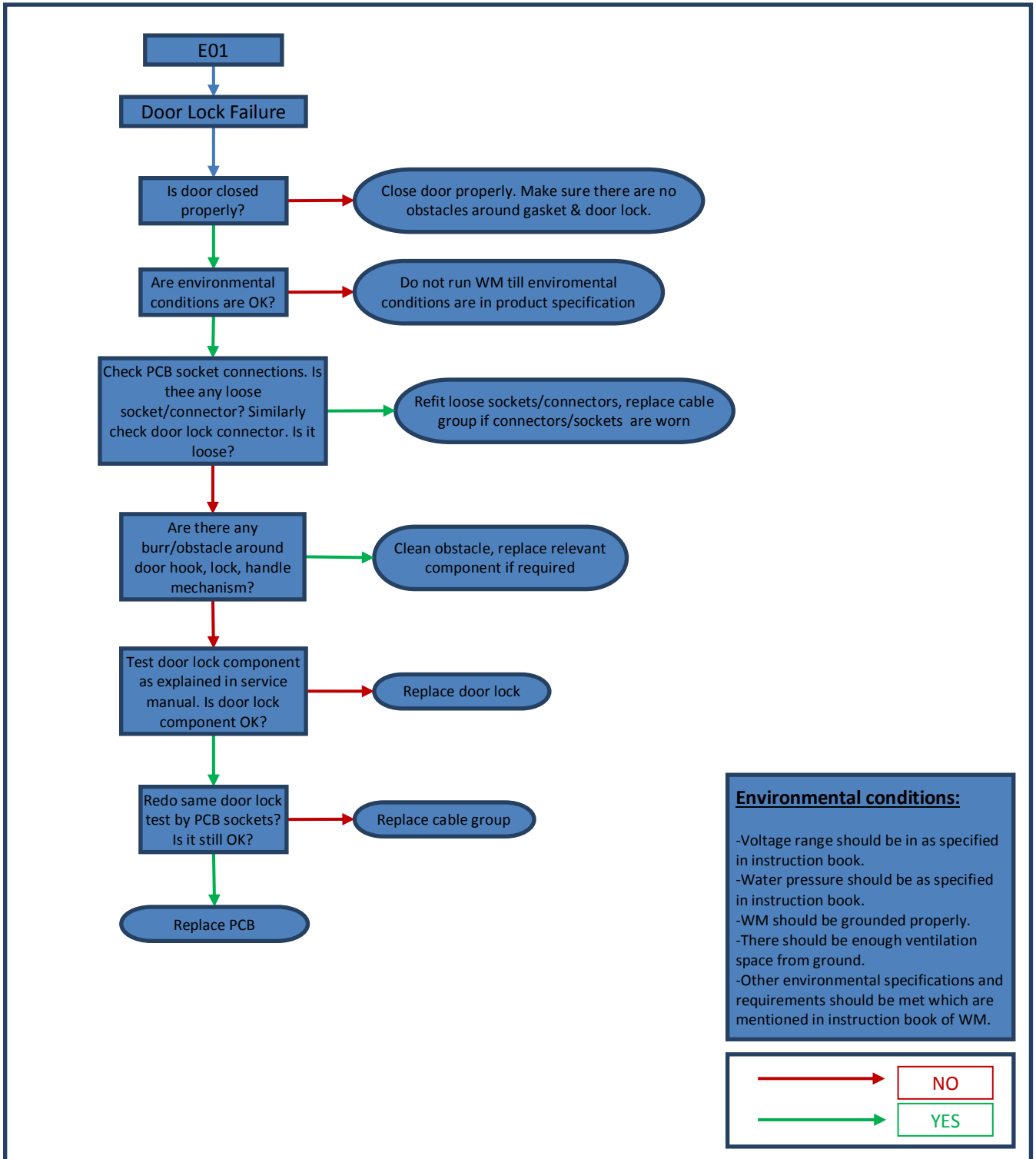

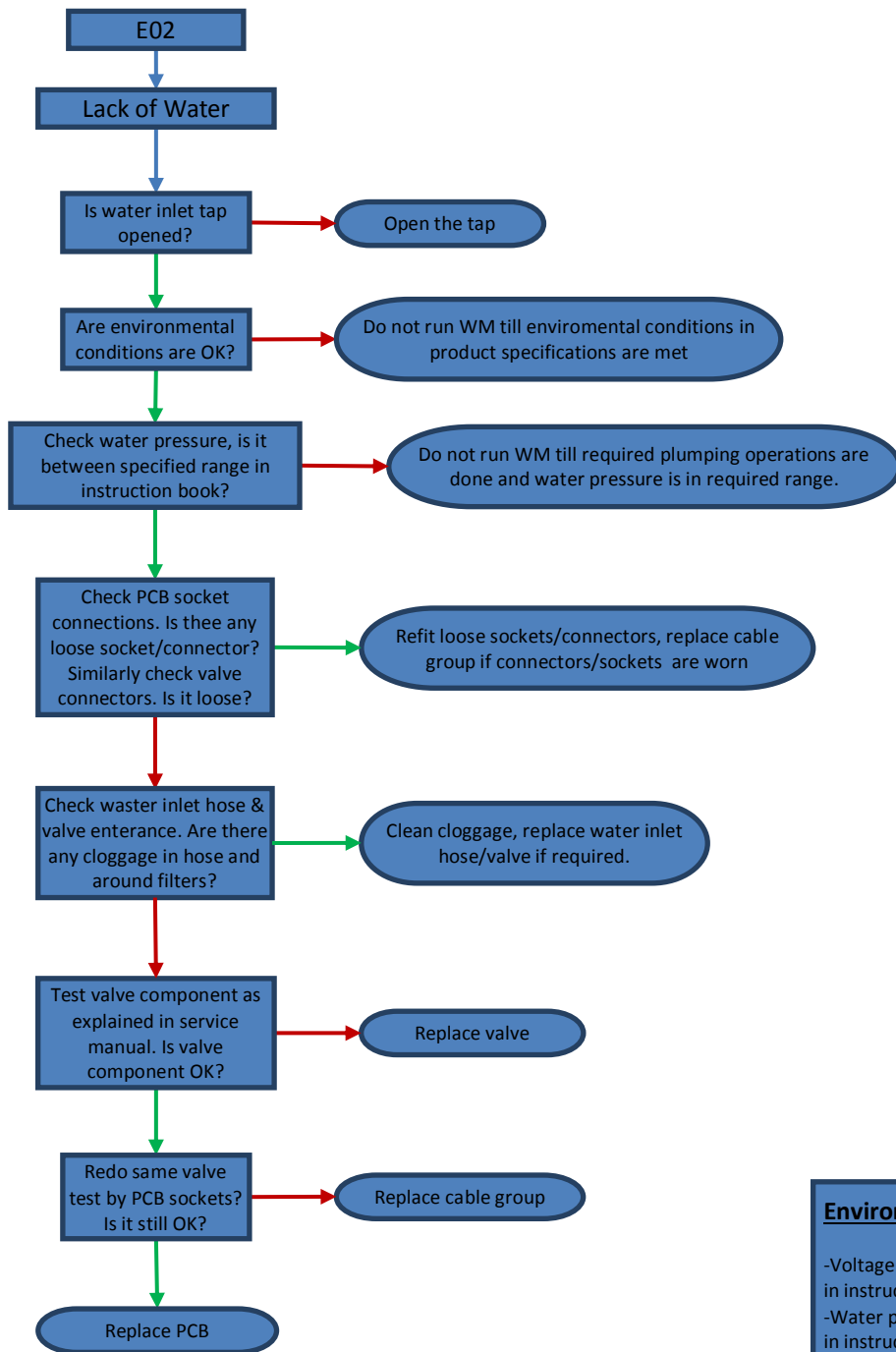

**Environmental conditions:**

- Voltage range should be in as specified in instruction book.
- Water pressure should be as specified in instruction book.
- WM should be grounded properly.
- There should be enough ventilation space from ground.
- Other environmental specifications and requirements should be met which are mentioned in instruction book of WM.

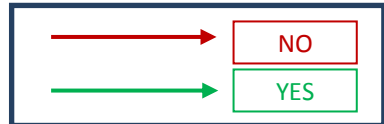

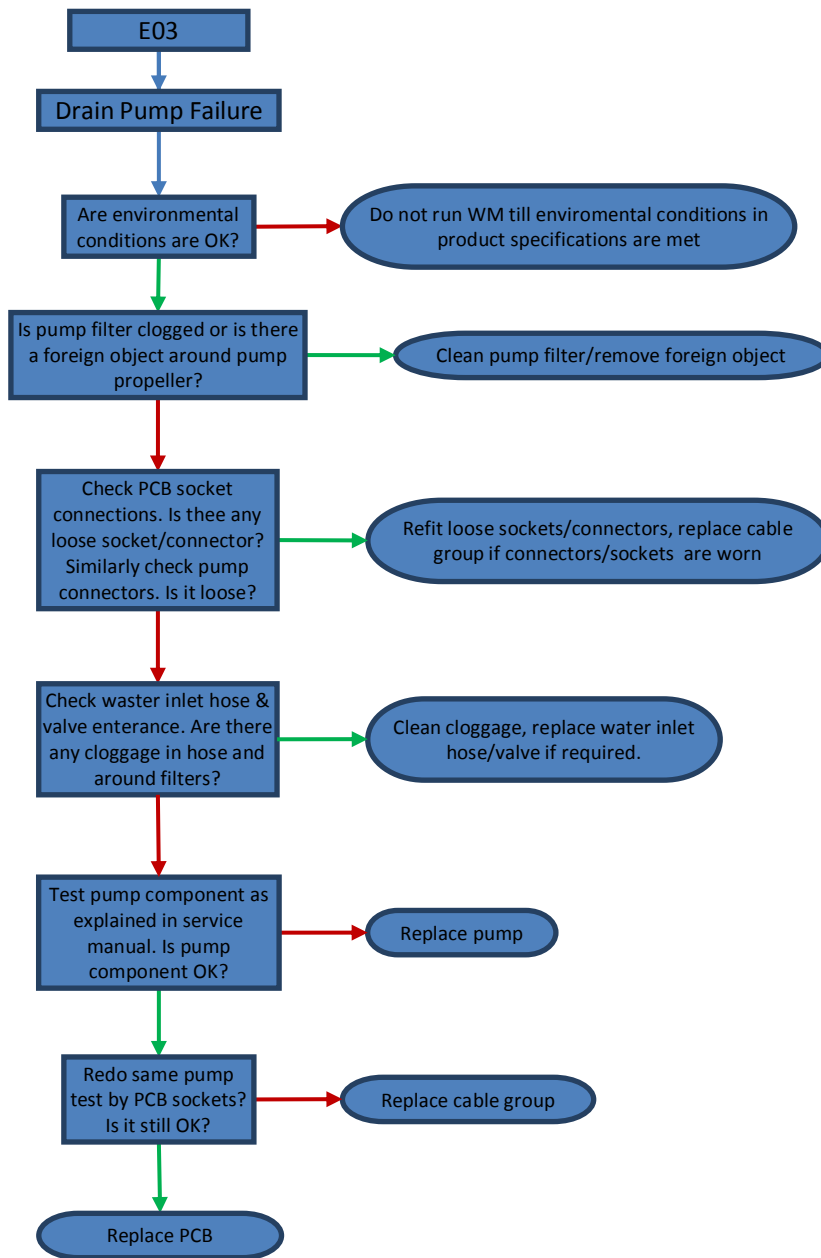

**Environmental conditions:**

- Voltage range should be in as specified in instruction book.
- Water pressure should be as specified in instruction book.
- WM should be grounded properly.
- There should be enough ventilation space from ground.
- Other environmental specifications and requirements should be met which are mentioned in instruction book of WM.

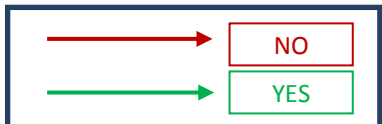



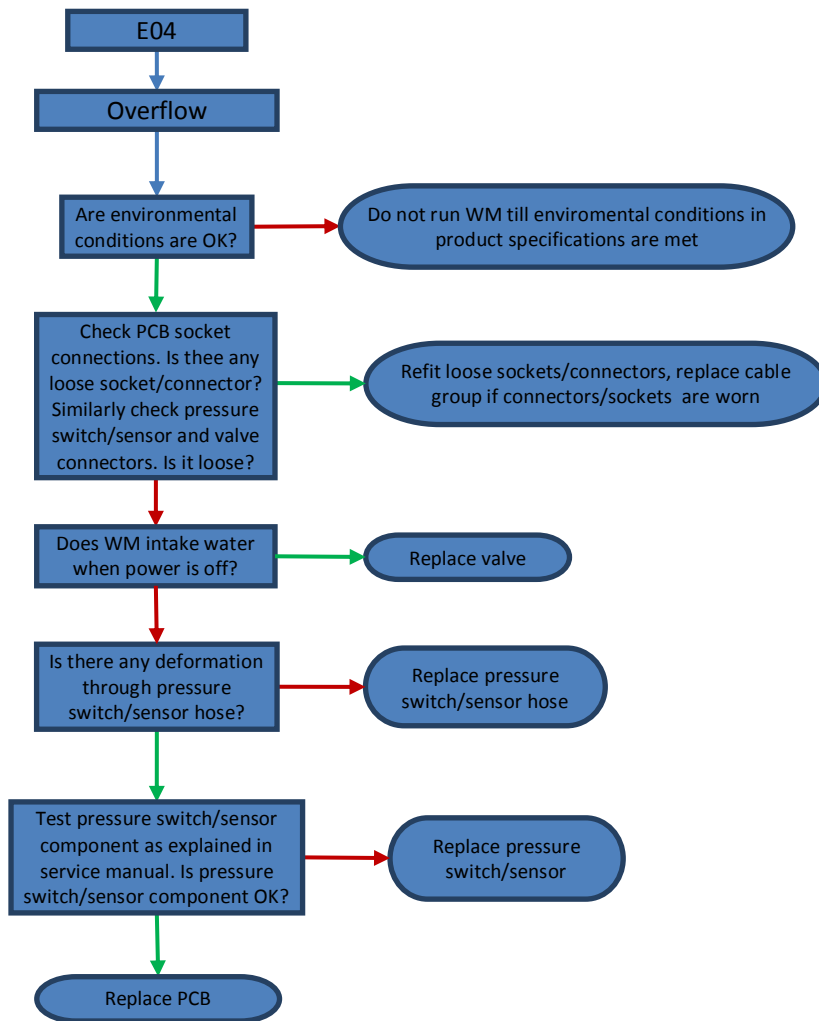

**Environmental conditions:**

- Voltage range should be in as specified in instruction book.
- Water pressure should be as specified in instruction book.
- WM should be grounded properly.
- There should be enough ventilation space from ground.
- Other environmental specifications and requirements should be met which are mentioned in instruction book of WM.

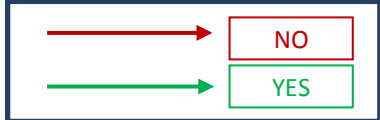

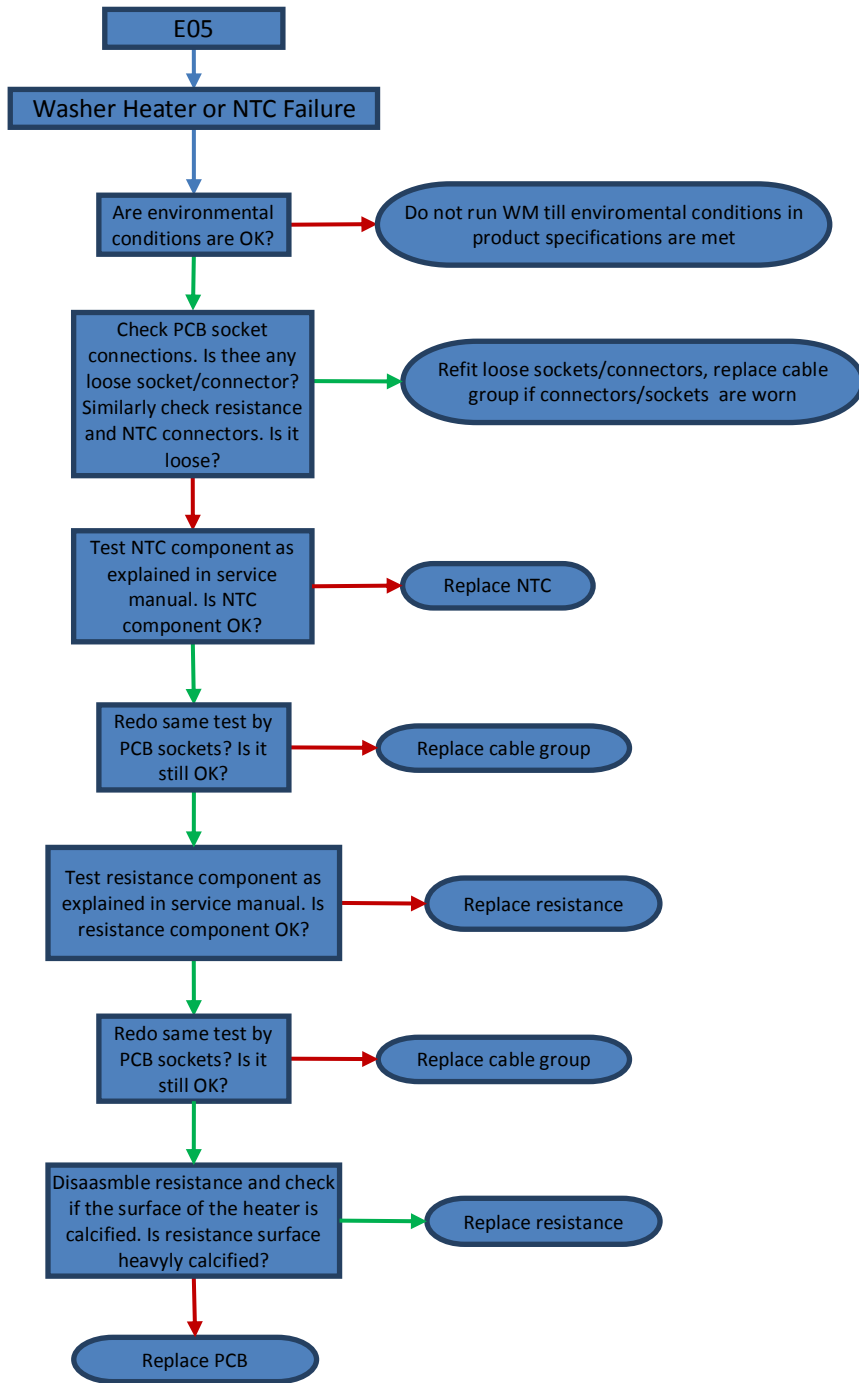

**Environmental conditions:**

- Voltage range should be in as specified in instruction book.
- Water pressure should be as specified in instruction book.
- WM should be grounded properly.
- There should be enough ventilation space from ground.
- Other environmental specifications and requirements should be met which are mentioned in instruction book of WM.

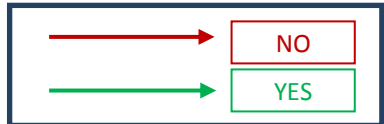

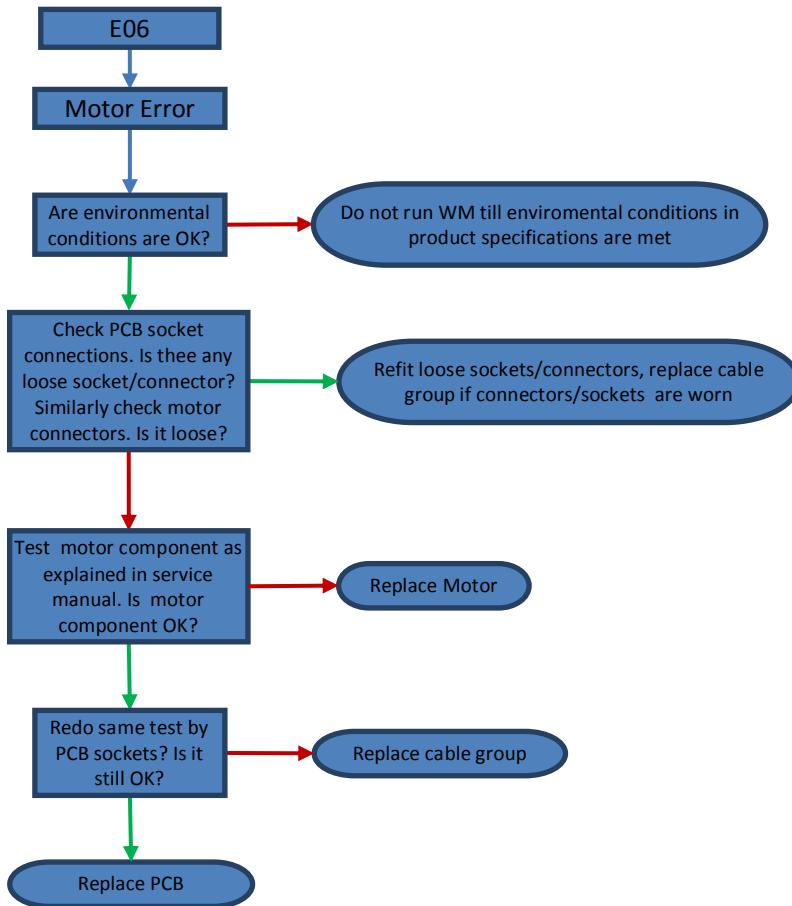

**Environmental conditions:**

- Voltage range should be in as specified in instruction book.
- Water pressure should be as specified in instruction book.
- WM should be grounded properly.
- There should be enough ventilation space from ground.
- Other environmental specifications and requirements should be met which are mentioned in instruction book of WM.

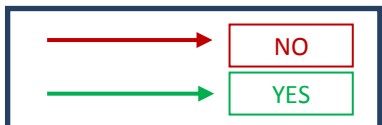

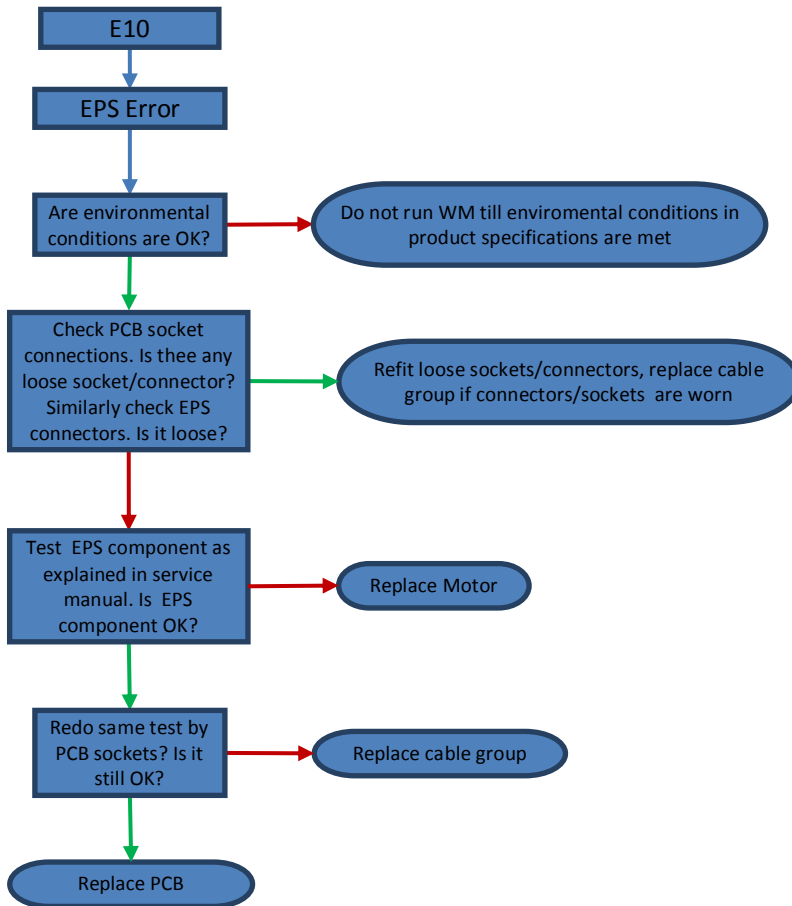

**Environmental conditions:**

- Voltage range should be in as specified in instruction book.
- Water pressure should be as specified in instruction book.
- WM should be grounded properly.
- There should be enough ventilation space from ground.
- Other environmental specifications and requirements should be met which are mentioned in instruction book of WM.

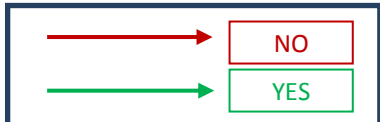

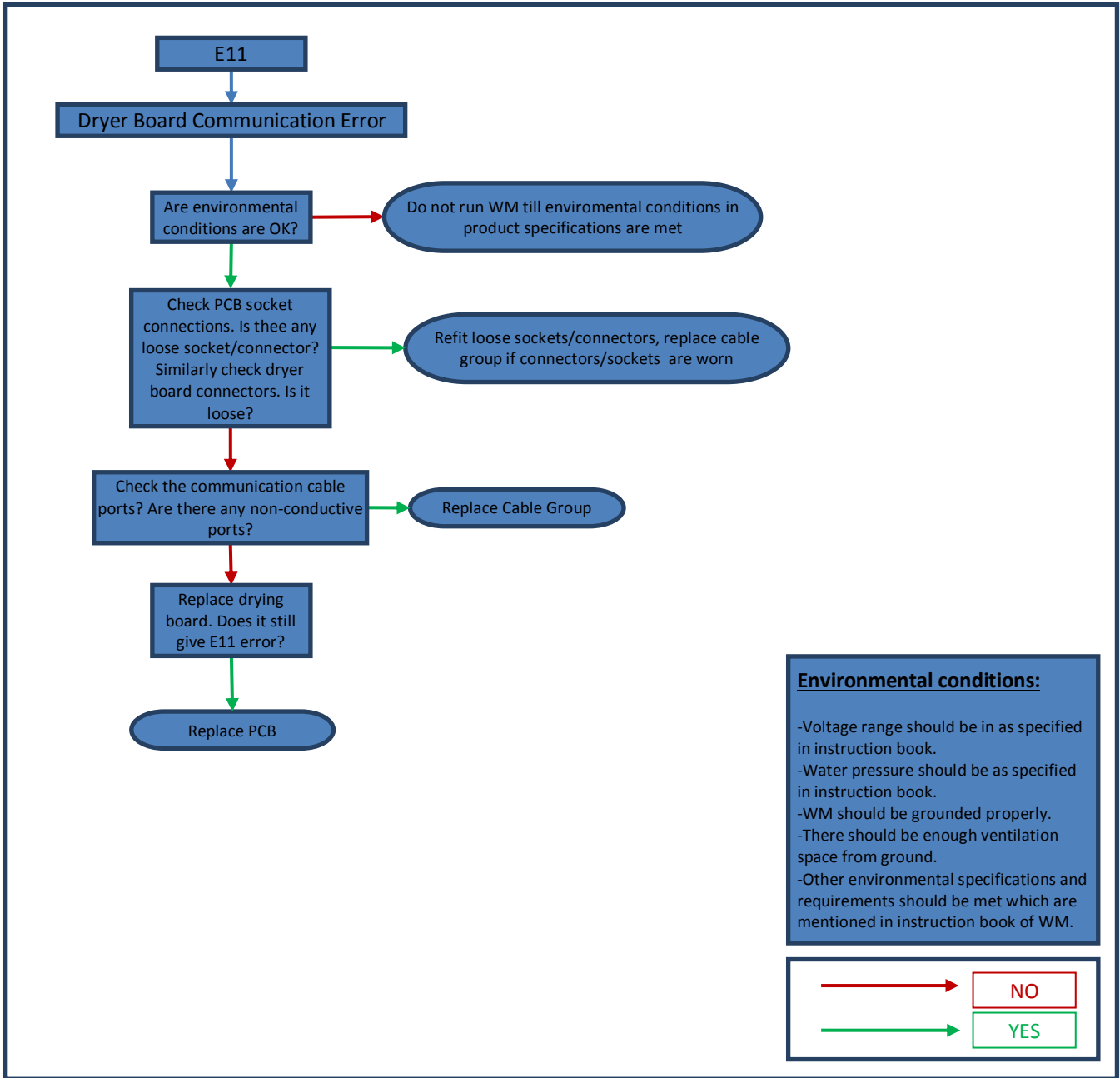

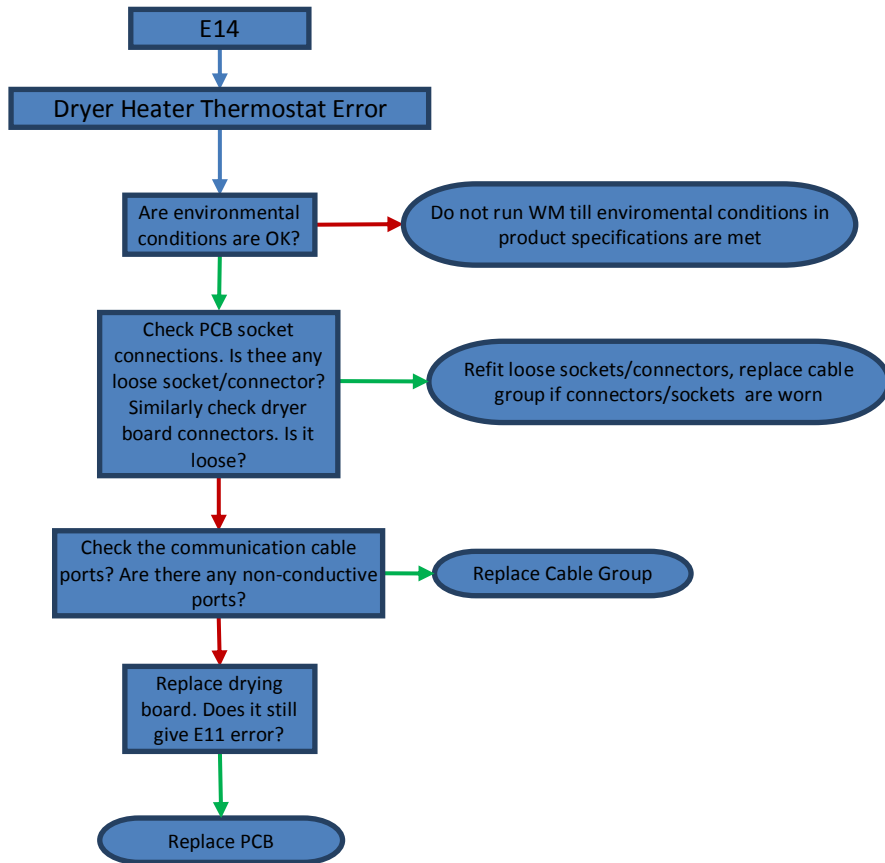

**Environmental conditions:**

- Voltage range should be in as specified in instruction book.
- Water pressure should be as specified in instruction book.
- WM should be grounded properly.
- There should be enough ventilation space from ground.
- Other environmental specifications and requirements should be met which are mentioned in instruction book of WM.

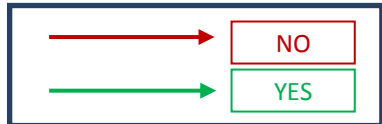

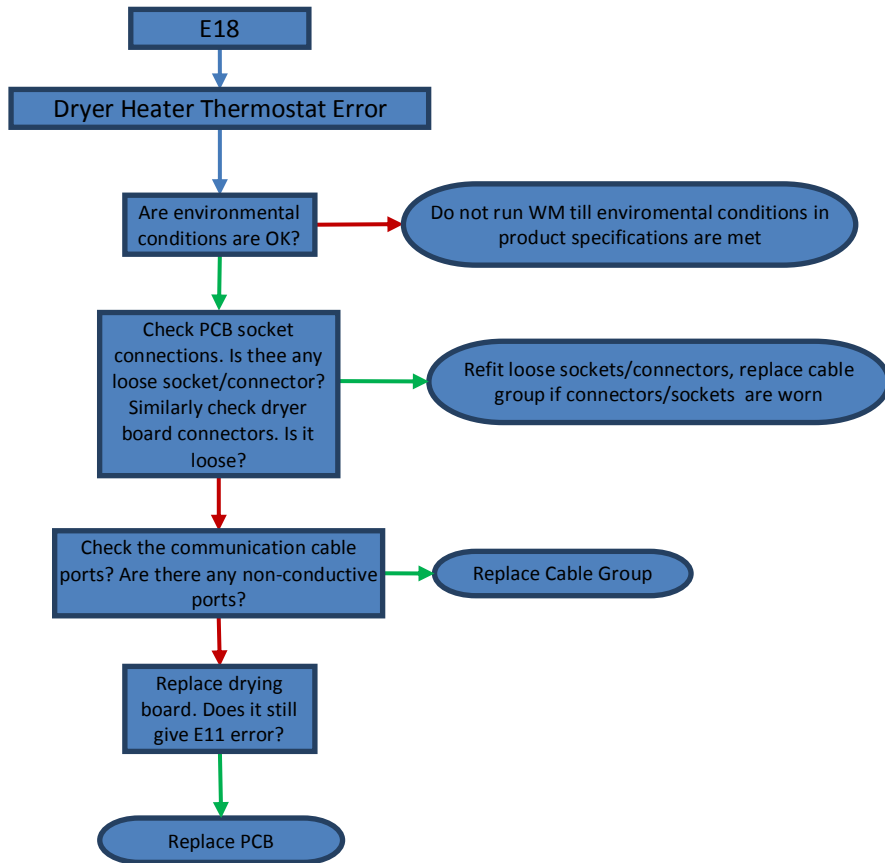

**Environmental conditions:**

- Voltage range should be in as specified in instruction book.
- Water pressure should be as specified in instruction book.
- WM should be grounded properly.
- There should be enough ventilation space from ground.
- Other environmental specifications and requirements should be met which are mentioned in instruction book of WM.

