



# Electrolux

## SERVICE MANUAL

## DISHWASHERS

FOR INTERNAL AND PARTNERS USE ONLY

© ELECTROLUX HOME PRODUCTS

Consumer Service - EMEA

Quality & Continuous Improvement - Technical Support

Dishwashers with electronic control system

### SERVICE MODE

- EDW 500
- EDW 1500
- EDW 1750
- EDW 750
- EDW 1510



EN

Publication number

599 83 22 - 07

Edition: 08/2019 - Rev. 0

# Introduction & Purpose

## CONTENTS:

Introduction & Purpose	Chapter 1
User Interface – Introduction	Chapter 2
EDW 500	Chapter 3.1
EDW 750	Chapter 3.2
EDW 1500	Chapter 3.3
EDW 1510	Chapter 3.4
EDW 1750	Chapter 3.4

## Purpose:

To describe all the Service Mode functions for the User Interfaces included on this Service Manual

## Abbreviations, Acronyms and Definitions

RTA	Remaining time adaptation
MCF	Machine Configuration File
NTC	Negative Temperature Coefficient resistor
PB100	New platform for dual BLDC machines (Global hydraulic)
DIVA2	Platform with single BLDC control in separate unit (MCB)
MCB	Motor Control Board (DIVA2)
ADO	Auto Door Opener



- Electrical appliances must be serviced only by qualified Service Engineers.
- Always use proper safety equipment.
- Always remove the plug from the power socket before touching internal components.

## Document Revisions

Revision	Date	Description	Author
V0.0	08/2019	Document creation	Rui Almeida

## User interface – Introduction

### User Interface – Modes and Function description

#### Reset

“Reset” is a special kind of User Operation to stop or deselect a running program. In Dorothea range, when this function is performed, the appliance will be in Startup mode with ECO program and its default option selected.

Reset can be performed in any state except the Startup mode.

Reset is done by pressing the reset key combination for at least 2 seconds or press the specific button dedicated to this function by the custom software.

The Reset key combination or specific Reset key is clearly indicated on the control panel as ‘Reset’ or ‘Cancel’.

#### User Mode

The full function User Mode includes:

- Water Hardness Setting
- Rinse Aid Level Setting
- End of Cycle Buzzer Setting
- Display on Floor Display Colour Setting
- ADO Setting

According to hardware configuration of the dishwasher and marketing requirement, User Mode in individual models can be a subset of above functions.

The User Mode functions are not described in this Service Manual since they are available on the User Manual.

#### Service Mode

The full function Service Mode includes:

- Fault Memory Reading
- Actuator Test
- LEDTest
- Functional Test cycle
- Enable/disable Extra Rinse
- Enable/disable Pulse Wash
- LCD brightness setting
- LCD contrast setting

According to hardware configuration of the dishwasher and marketing requirement, Service Mode in individual models can be a subset of above functions.

All the Service Mode functions are described on this user Service Manual.

### Service Mode – Function description

#### Alarm Reading and Actuator Test

After accessed Service mode to get the saved alarms and test actuators.

Details of alarm code displaying are in later Alarm Code section.

#### LED Test / Delete Alarm Memory

To test the LEDS and erase alarm codes from memory.

#### Functional Test Cycle

Run a test cycle. It runs as a normal wash cycle. It can be cancelled or run to its end.

#### Enable/disable Extra Rinse

An additional cold rinse phase can be added to the cycles to improve wash performance. In factory (default) settings, this is disabled.

Use this function to enable or disable the Extra Rinse.

#### Enable/disable Pulse Wash

Pulse Wash can be disabled from the cycles to improve wash performance. In factory (default) settings, this is enabled.

Use this function to disable or enable Pulse Wash.

# EDW500

## EDW500

### Styling Overview

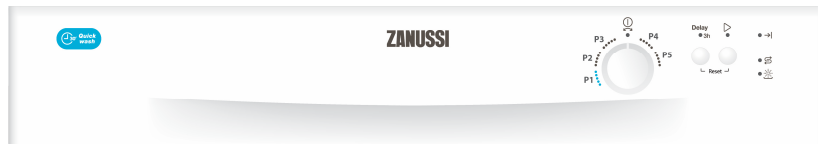

### Location of LEDs, Rotary and Push Buttons

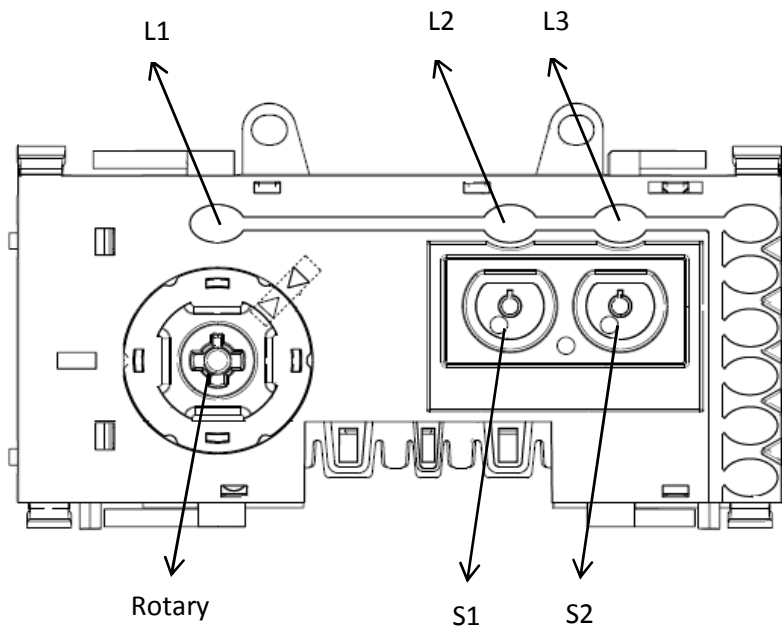

### Reset

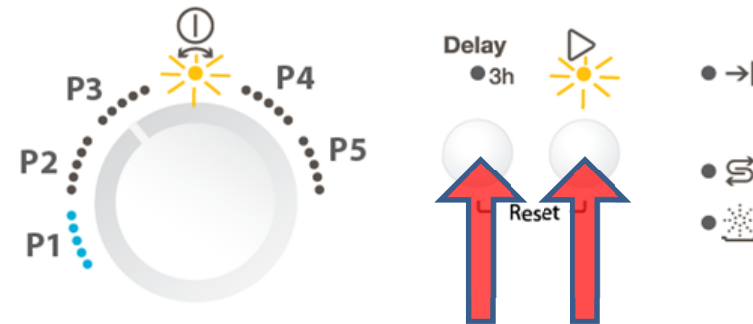

There are variants of EDW500 models which have only 1 button. For these single-button models, press and hold the single button to reset.

### Access Service Mode

The Service Mode can only be accessed after the Reset function has been carried out and the appliance is switched off.

When machine is off, press and hold S1 while switching the appliance on by turning the rotary to the 1<sup>st</sup> position on the left (P3), keep holding the buttons for 4 seconds.

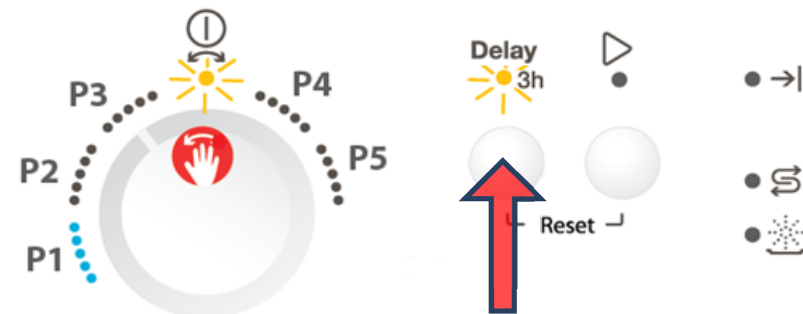

## EDW500

For variants that have only one button, use the only button instead of S1.

### Alarm Reading and Actuator Test

After accessed Service mode (L1 and L2 blinking):

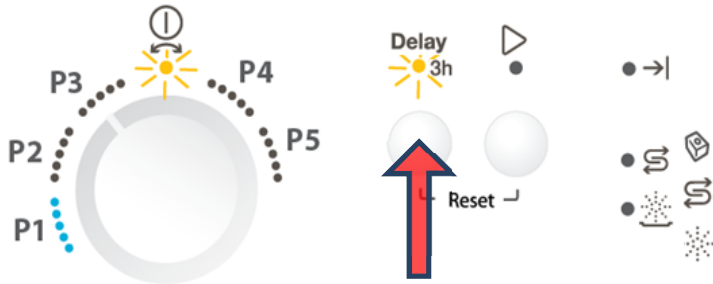

1. Press button S1 to show the first alarm code.
  - L1 and L2 keeps blinking to indicate the machine is in service modes.
  - The first alarm code saved is shown by the blink sequence of 2 LEDs in the right column. For descriptions of alarm codes, please see later Alarm Codes section.
2. Press button S1 again to show the second alarm code.
3. Press button S1 once more to show the third alarm code.
4. Press button S1 the fourth time to move to Actuator Test. Press button S1 repeatedly will sequentially turn on one actuator at a time.
  - L1 and L2 blink to indicate the machine is in service modes. L4 is turned on to indicate the machine is in Actuator Test.
  - The following table shows the number of press on S1 and the actuator is turned on.

Number of S1 Pressed	Actuator Number in Display	Actuator	Comment
4	4	Regeneration Valve	
5	5	Drain Pump	
6	6	Inlet Valve	Off when water level reached
7	7	Heater	On only if water level reached
8	8	Wash Pump	
9	9	Dispenser	
10	10	Auto door opening	

5. Press button S1 when actuator number 10 is activated, the machine will cycle back to Alarm reading and show the first alarm code saved.
6. Switching off the appliance will exit Service mode.

For variants that have only one button, use the only button instead of S1.

### LED Test / Delete Alarm Memory

After accessed Service mode (L1 and L2 blinking):

1. Turn the rotary to the 2<sup>nd</sup> position on the left (P2).

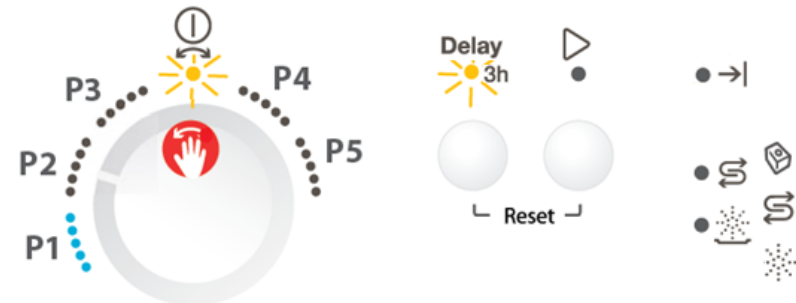

## EDW500

### 2. Press button S1 to start this function

- All used LEDs blink 5 second on 1 second off.
- If a buzzer is equipped, it beeps for 5 seconds.
- The alarm codes saved in memory are erased.

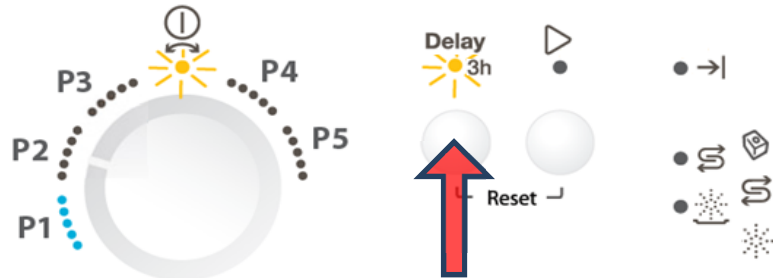

### 3. Switching off the appliance will exit Service mode.

For variants that have only one button, use the only button instead of S1.

## Functional Test Cycle

After accessed Service mode (L1 and L2 blinking):

1. Turn the rotary to the 3<sup>rd</sup> position on the left (P1).

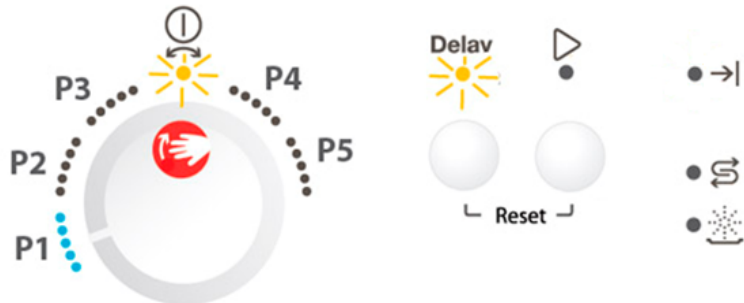

2. Press button S1 to start the test cycle. The cycle will not start if door is opened.

- The test cycle runs as a normal wash cycle. It can be cancelled or run to its end.
- During running, L1 stays on and L2 blinks. If phase indication LED presented, the 'Wash' LED blinks when the cycle is running. After the cycle ends, the End LED turns on.

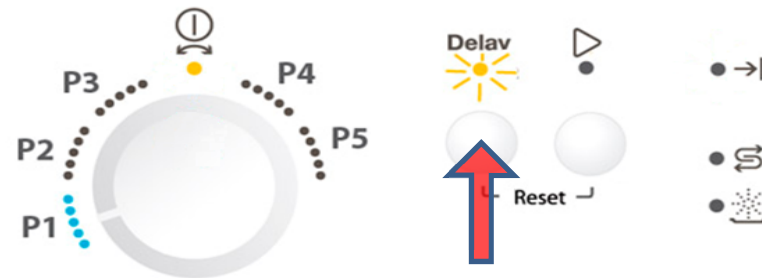

For variants that have only one button, use the only button instead of S1.

## Enable/disable Extra Rinse

Not available for this User Interface.

## Enable/disable Pulse Wash

Not available for this User Interface.

# EDW750

## EDW 750

### Styling Overview

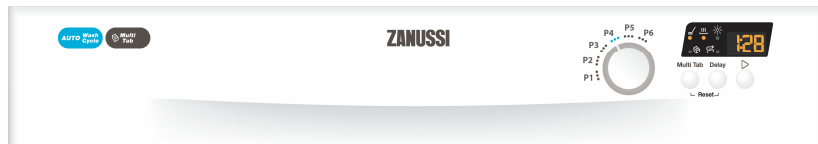

### Location of LEDs, Rotary and Push Buttons

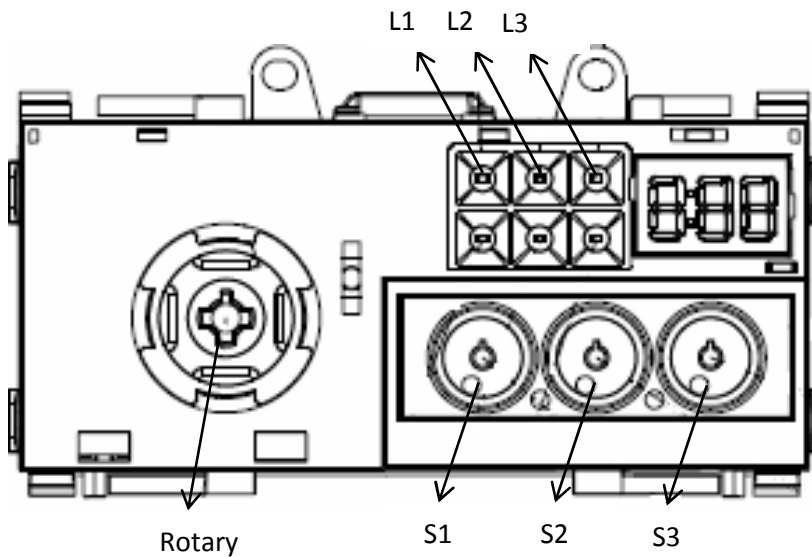

### Reset

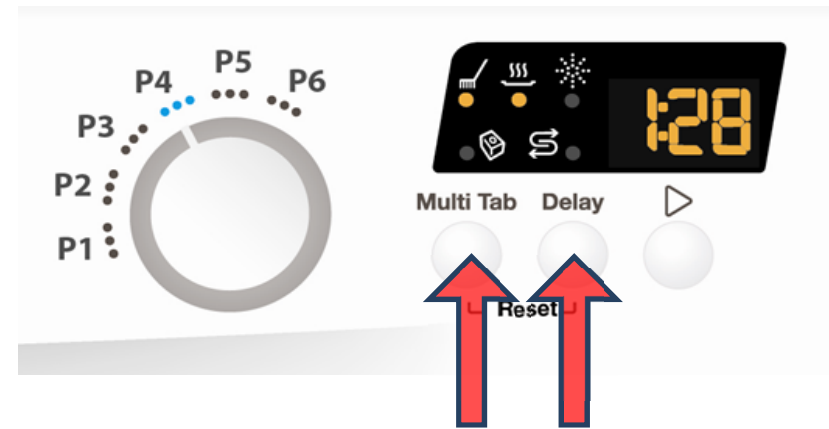

### Access Service Mode

The Service Mode can only be accessed after the Reset function has been carried out and the appliance is switched off. When machine is off, turn the rotary to the top position (P5).

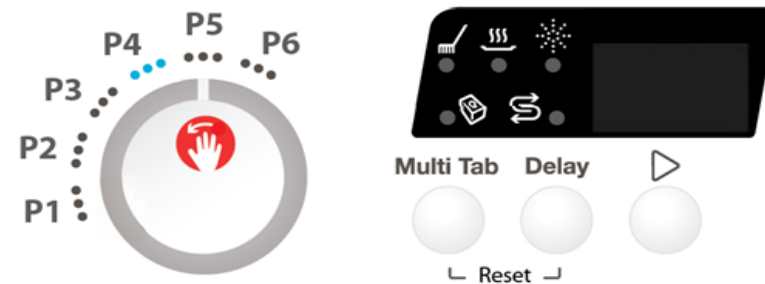



## EDW750

Press and hold button S1+S3 simultaneously while switching the appliance on, keep holding the buttons for 4 seconds.

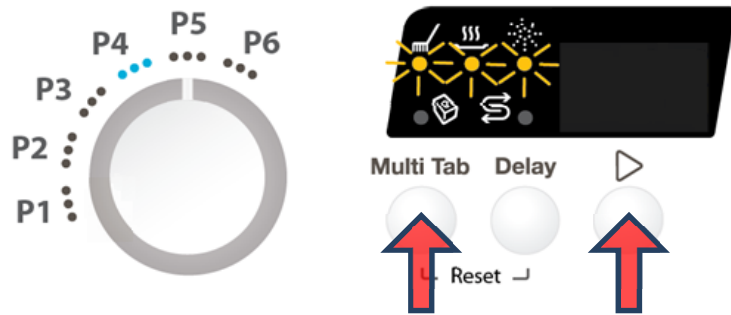

L1, L2 and L3 blink to indicate that Service mode is accessed.

### Alarm Reading and Actuator Test

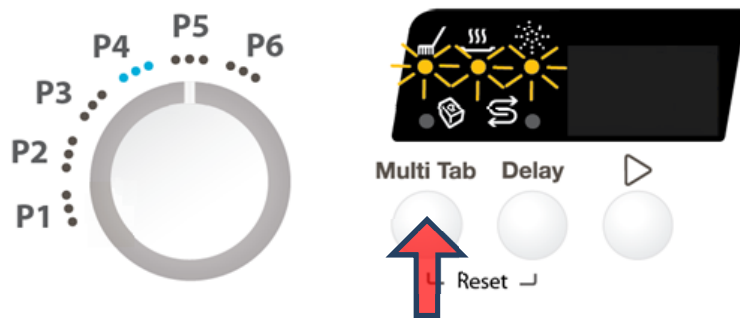

After accessed Service mode (L1, L2 and L3 blinking):

1. Press button S1 to show the first alarm code.
  - L1 blinks to indicate the machine is in Alarm Reading.

- The first alarm code saved is shown in the display.
2. Press button S1 again to show the second alarm code.
3. Press button S1 once more to show the third alarm code.
4. Press button S1 the fourth time to move to Actuator Test. Press button S1 repeatedly will sequentially turn on one actuator at a time.
  - L1 is turned off. L2 blinks to indicate the machine is in Actuator Test.
  - The actuator number is shown in the display.
5. Press button S1 when actuator number 10 is activated, the machine will cycle back to Alarm reading and show the first alarm code saved.
6. Switching off the appliance will exit Service mode.

Number of S1 Pressed	Actuator Number in Display	Actuator	Comment
4	4	Regeneration Valve	
5	5	Drain Pump	
6	6	Inlet Valve	Off when water level reached
7	7	Heater	On only if water level reached
8	8	Wash Pump	
9	9	Dispenser	
10	10	Auto door opening	

### LED Test / Delete Alarm Memory

After accessed Service mode (L1, L2 and L3 blinking):

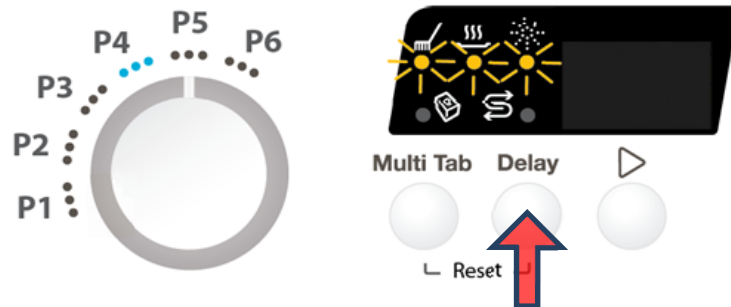

1. Press button S2 to start this function.
  - All used LEDs and display (show "8:88") blinks 5 second on 1 second off.
  - If a buzzer is equipped, it beeps for 5 seconds.
  - The alarm codes saved in memory are erased.
2. Switching off the appliance will exit Service mode.

### Functional Test Cycle

After accessed Service mode (L1, L2 and L3 blinking):

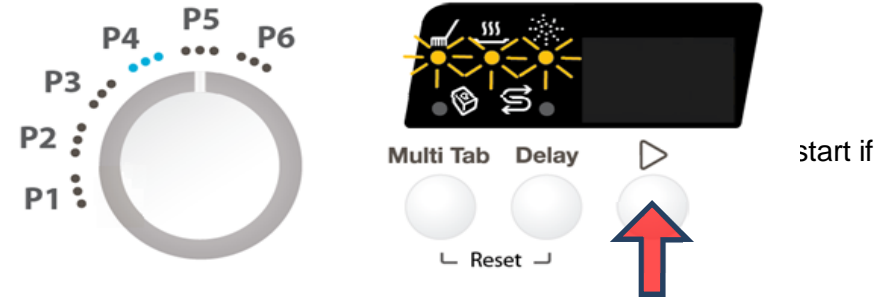

- Press button S3 to start the test cycle. The cycle will not start if door is opened.
- L3 blinks for the duration of the test cycle.
  - Display shows the remaining time of test cycle.
3. The test cycle runs as a normal wash cycle. It can be cancelled or run to its end.

## EDW750

### Enable/disable Extra Rinse

After accessed Service mode (L1, L2 and L3 blinking):

1. Press button S1+S2 to enter this function.

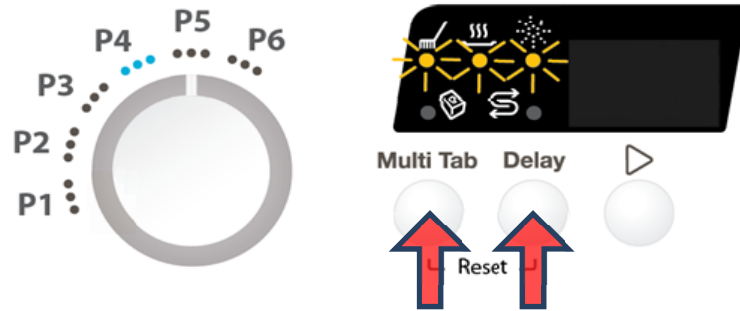

- L1 blinks indicating it is in Extra Rinse setting mode.
- Display show the current setting of Extra Rinse. "0E" for disabled, "1E" for enabled

2. Press button S1 to change the setting

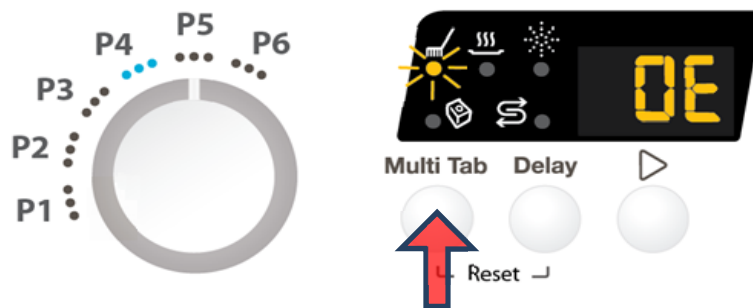

3. Switching off the appliance will exit Service mode.

### Enable/disable Pulse Wash

After accessed Service mode (L1, L2 and L3 blinking):

1. Press button S2+S3 to enter this function.

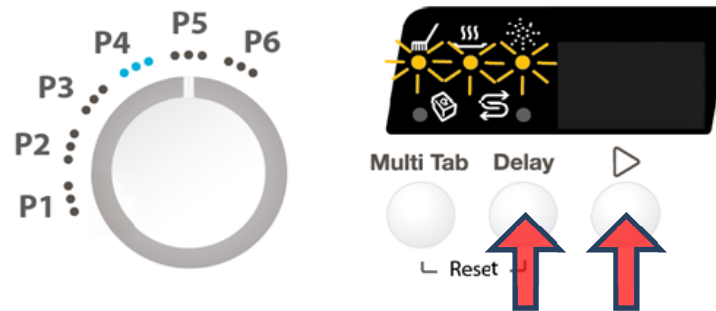

- L2 blinks indicating it is in Pulse Wash setting mode.
- Display show the current setting of Pulse Wash. "0P" for disabled, "1P" for enabled

2. Press button S2 to change the setting

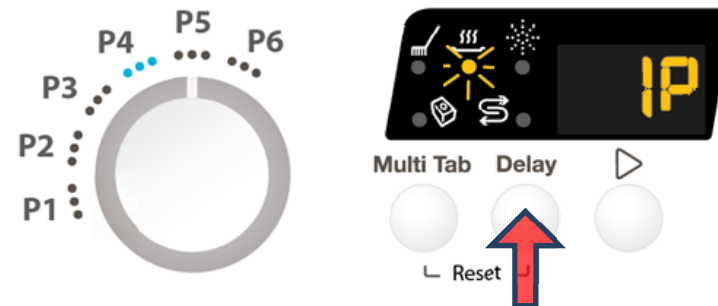

3. Switching off the appliance will exit Service mode.

# EDW1500

## EDW 1500

### Styling Overview

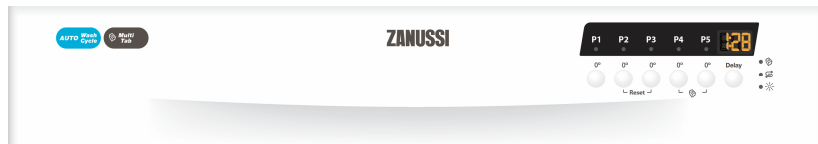

### Location of LEDs, Rotary and Push Buttons

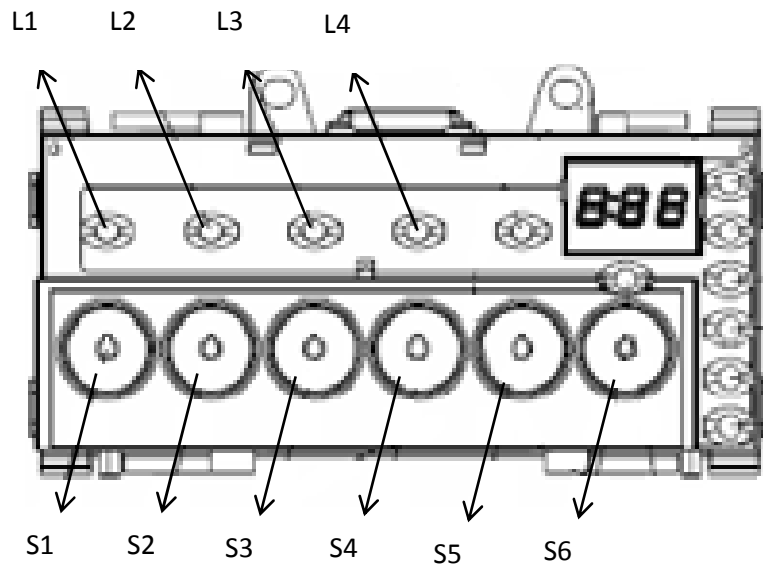

### Reset

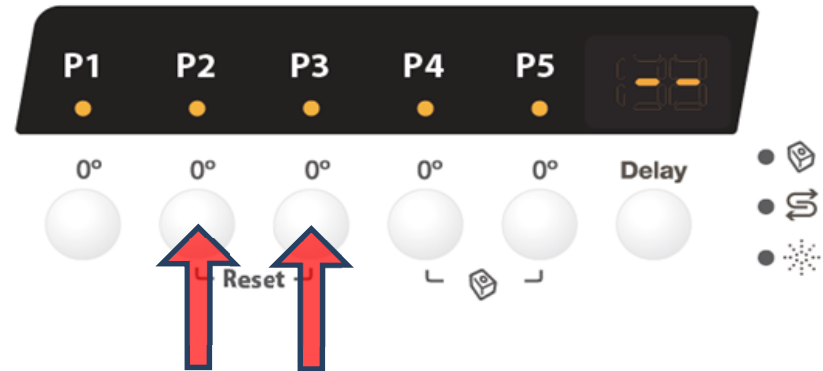

### Access Service Mode

The Service Mode can only be accessed after the Reset function has been carried out and the appliance is switched off.

When machine is off, press and hold button S1+S3 simultaneously while switching the appliance on, keep holding the buttons for 4 seconds.

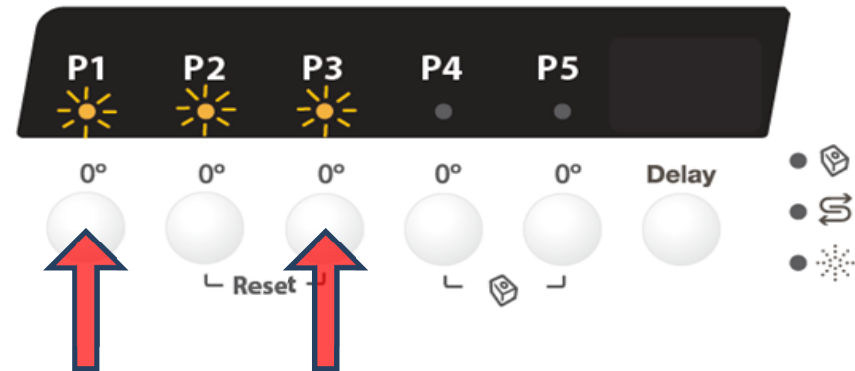

L1, L2 and L3 blink to indicate that Service mode is accessed.

## EDW1500

### Alarm Reading and Actuator Test

After accessed Service mode (L1, L2 and L3 blinking):

- Press button S1 to show the first alarm code.
  - L1 blinks to indicate the machine is in Alarm Reading.
  - The first alarm code saved is shown in the display. . Please see later Alarm Codes section.

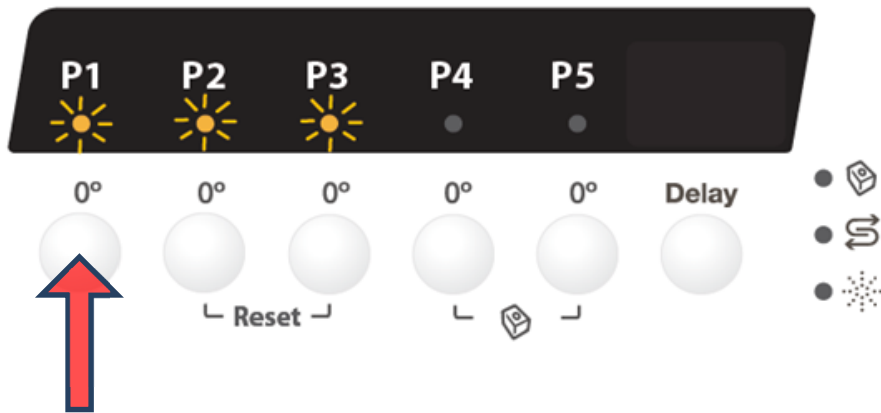

- Press button S1 again to show the second alarm code.
- Press button S1 once more to show the third alarm code.
- Press button S1 the fourth time to move to Actuator Test. Press button S1 repeatedly will sequentially turn on one actuator at a time.
  - L1 is turned off. L2 blinks to indicate the machine is in Actuator Test.
  - The actuator number is shown in the display.

- Press button S1 when actuator number 10 is activated, the machine will cycle back to Alarm reading and show the first alarm code saved.
- Switching off the appliance will exit Service mode.

Number of S1 Pressed	Actuator Number in Display	Actuator	Comment
4	4	Regeneration Valve	
5	5	Drain Pump	
6	6	Inlet Valve	Off when water level reached
7	7	Heater	On only if water level reached
8	8	Wash Pump	
9	9	Dispenser	
10	10	Auto door opening	

### LED Test / Delete Alarm Memory

After accessed Service mode (L1, L2 and L3 blinking):

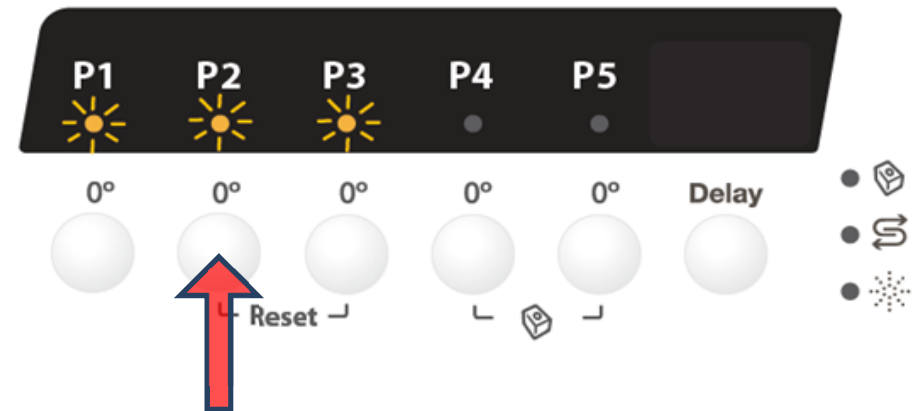

# EDW1500

1. Press button S2 to start this function.
  - All used LEDs and display (show "8:88") blinks 5 second on 1 second off.
  - If a buzzer is equipped, it beeps for 5 seconds.
  - The alarm codes saved in memory are erased.
2. Switching off the appliance will exit Service mode.

## Functional Test Cycle

After accessed Service mode (L1, L2 and L3 blinking):

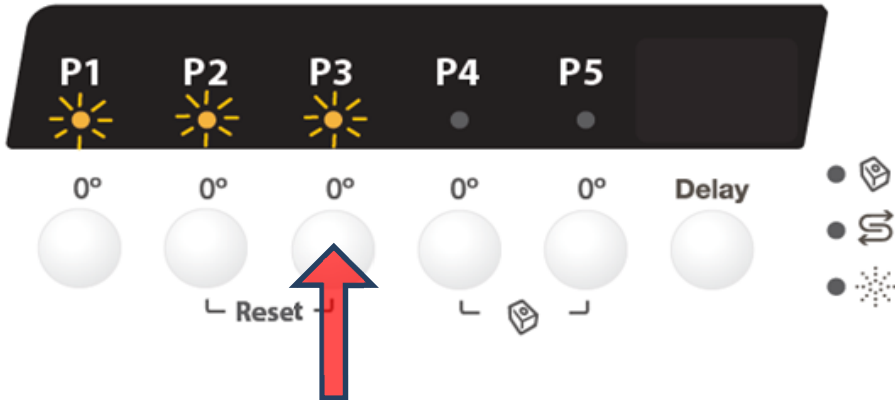

1. Press button S3 to start the test cycle. The cycle will not start if door is opened.
  - L3 blinks for the duration of the test cycle.
  - Display shows the remaining time of test cycle.
  - The test cycle runs as a normal wash cycle. It can be cancelled or run to its end.

## Enable/disable Extra Rinse

After accessed Service mode (L1, L2 and L3 blinking):

1. Press button S1+S2 to enter this function.
  - L1 blinks indicating it is in Extra Rinse setting mode.
  - Display show the current setting of Extra Rinse. "0E" for disabled, "1E" for enabled

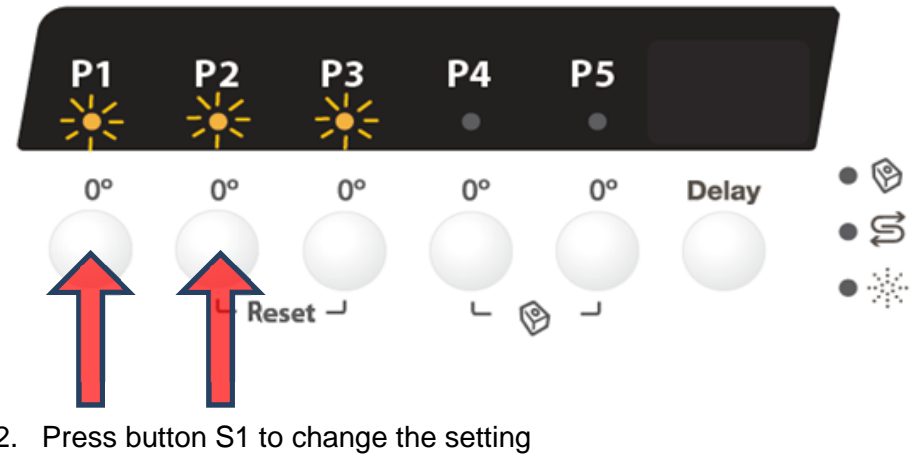

2. Press button S1 to change the setting

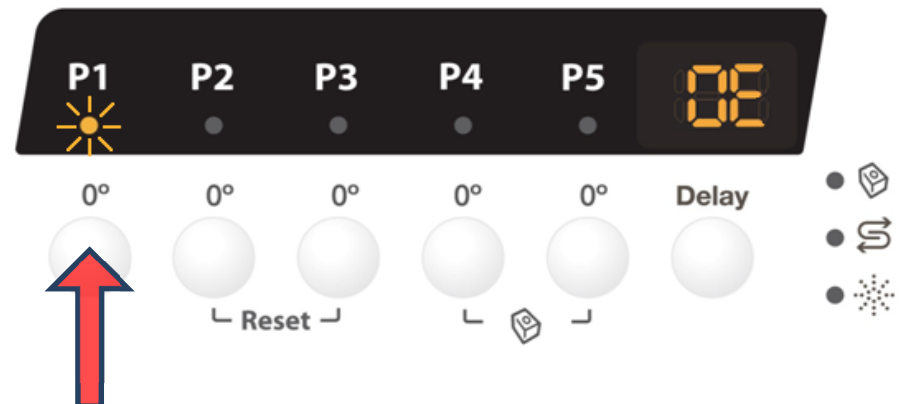

## EDW1500

3. Switching off the appliance will exit Service mode.

### Enable/disable Pulse Wash

After accessed Service mode (L1, L2 and L3 blinking):

1. Press button S2+S3 to enter this function.
  - L2 blinks indicating it is in Pulse Wash setting mode.
  - Display show the current setting of Pulse Wash. "0P" for disabled, "1P" for enabled

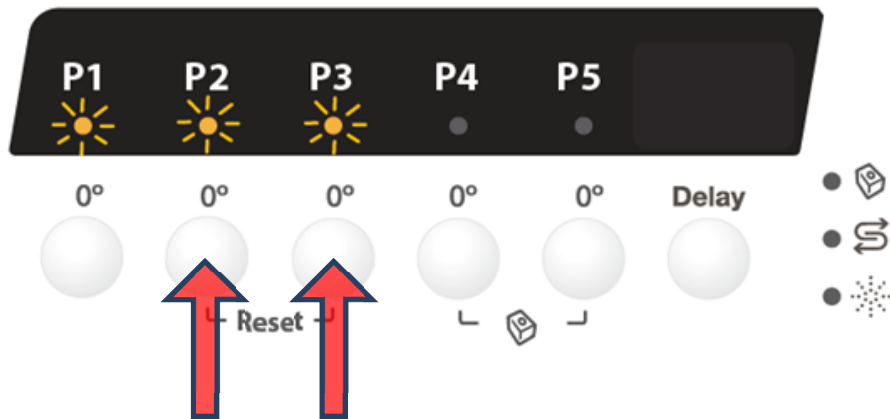

2. Press button S2 to change the setting

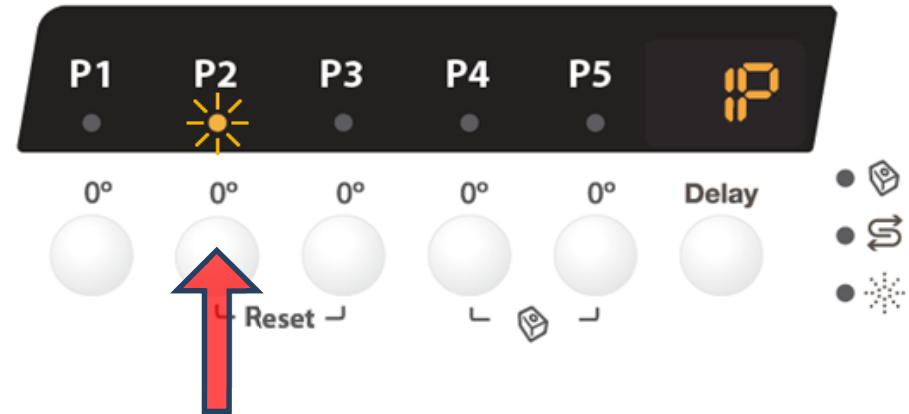

3. Switching off the appliance will exit Service mode.

# EDW1510 / EDW1750

## EDW 1510 / EDW1750

### Styling Overview

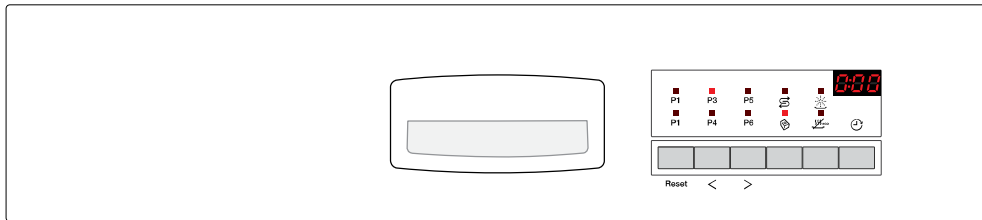

### Location of LEDs and Push Buttons

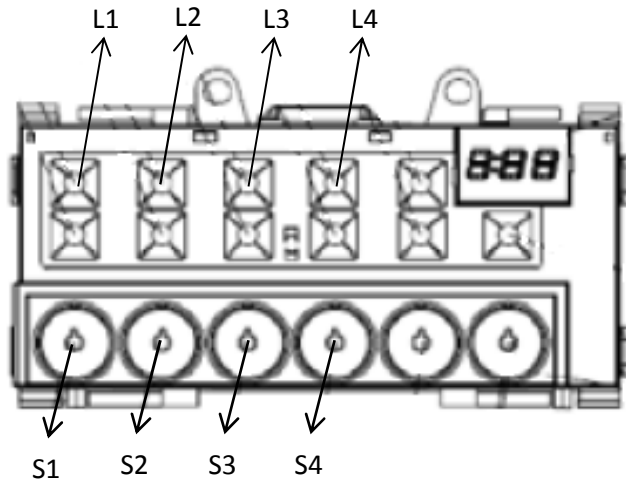

### Reset

Press the S1, which is dedicated to this function.

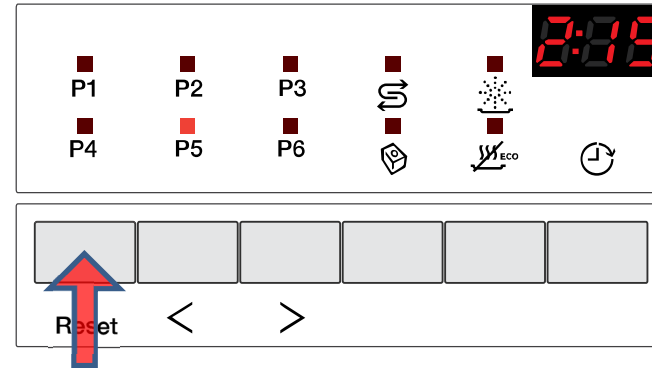

### Access Service Mode

When machine is off, press and hold button S1+S3 simultaneously while switching the appliance on, keep holding the buttons for 4 seconds.

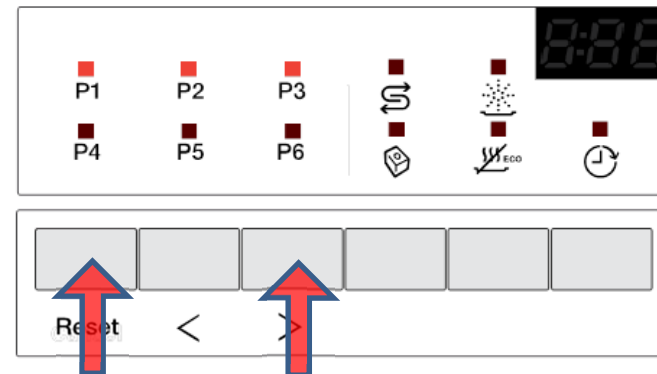



## EDW1510 / EDW1750

L1, L2 and L3 blink to indicate that Service mode is accessed.

### Alarm Reading and Actuator Test

After accessed Service mode (L1, L2 and L3 blinking):

- Press button S1 to show the first alarm code.
  - L1 blinks to indicate the machine is in Alarm Reading.
  - The first alarm code saved is shown in the display. Please see later Alarm Codes section.

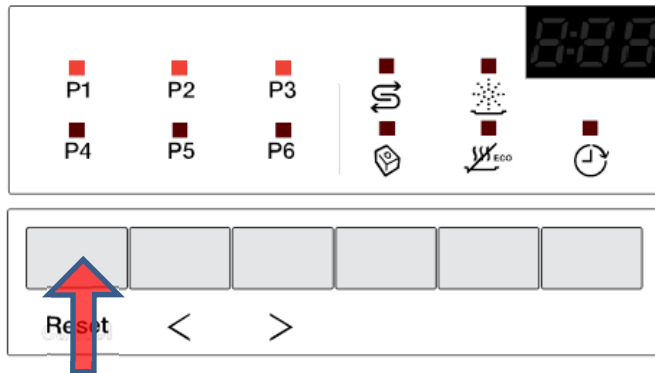

- Press button S1 again to show the second alarm code.
- Press button S1 once more to show the third alarm code.
- Press button S1 the fourth time to move to Actuator Test. Press button S1 repeatedly will sequentially turn on one actuator at a time.
  - L1 is turned off. L2 blinks to indicate the machine is in Actuator Test.
  - The actuator number is shown in the display.

- Press button S1 when actuator number 10 is activated, the machine will cycle back to Alarm reading and show the first alarm code saved.
- Switching off the appliance will exit Service mode.

Number of S1 Pressed	Actuator Number in Display	Actuator	Comment
4	4	Regeneration Valve	
5	5	Drain Pump	
6	6	Inlet Valve	Off when water level reached
7	7	Heater	On only if water level reached
8	8	Wash Pump	
9	9	Dispenser	
10	10	Auto door opening	

### LED Test / Delete Alarm Memory

After accessed Service mode (L1, L2 and L3 blinking):

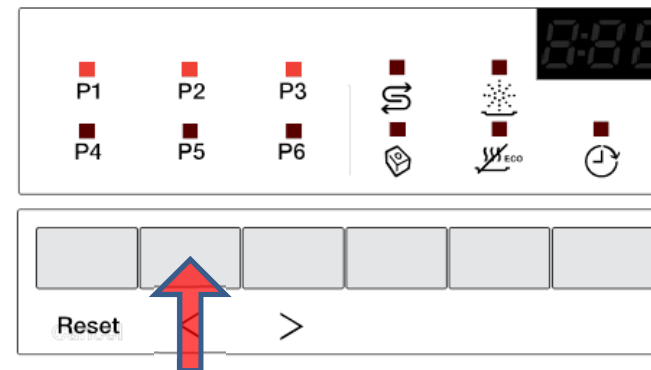

## EDW1510 / EDW1750

1. Press button S2 to start this function.
  - All used LEDs and display (show "8:88") blinks 5 second on 1 second off.
  - If a buzzer is equipped, it beeps for 5 seconds.
  - The alarm codes saved in memory are erased.
2. Switching off the appliance will exit Service mode.

### Functional Test Cycle

After accessed Service mode (L1, L2 and L3 blinking):

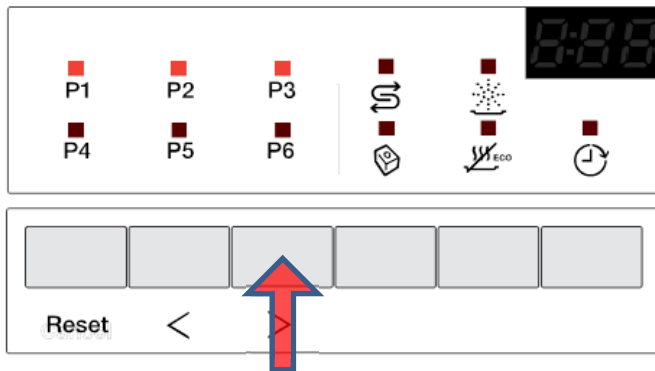

1. Press button S3 to start the test cycle. The cycle will not start if door is opened.
  - L3 blinks for the duration of the test cycle.
  - Display shows the remaining time of test cycle.
  - The test cycle runs as a normal wash cycle. It can be cancelled or run to its end.

### Enable/disable Extra Rinse

After accessed Service mode (L1, L2 and L3 blinking):

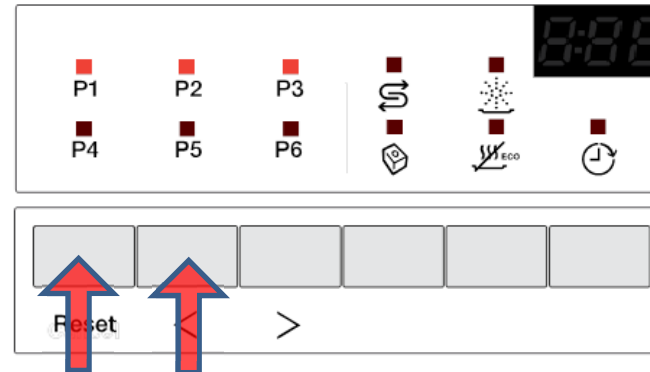

1. Press button S1+S2 to enter this function.
  - L1 blinks indicating it is in Extra Rinse setting mode.
  - Display show the current setting of Extra Rinse. "0E" for disabled, "1E" for enabled.
2. Press button S1 to change the setting.

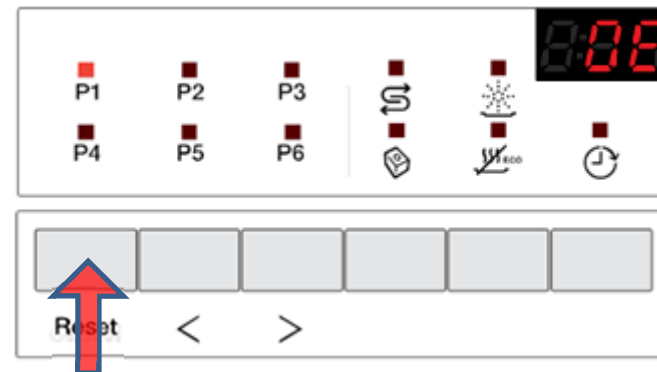

## EDW1510 / EDW1750

3. Switching off the appliance will exit Service mode.

3. Switching off the appliance will exit Service mode.

### Enable/disable Pulse Wash

After accessed Service mode (L1, L2 and L3 blinking):

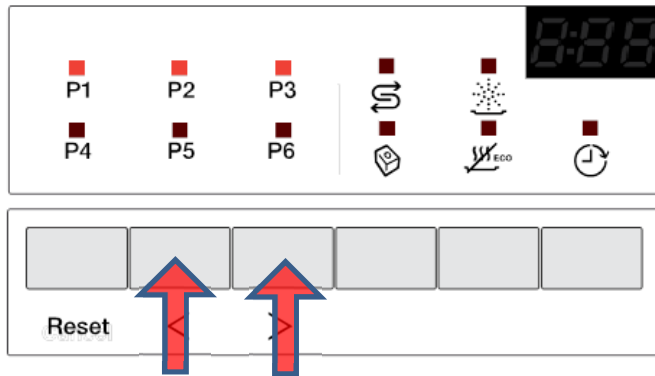

1. Press button S2+S3 to enter this function.

- L2 blinks indicating it is in Pulse Wash setting mode.
- Display show the current setting of Pulse Wash. "0P" for disabled, "1P" for enabled

2. Press button S2 to change the setting

