



Electrolux

SERVICE MANUAL

Food Preservation

ZRT48202

Document Revisions

Rev.	Date	Description	Author
00	05/2019	Document creation	Rui Almeida

EN

Publication number
599 83 05 - 84
Edition: 05/2019 - Rev. 00

FOR INTERNAL AND PARTNERS USE ONLY

© ELECTROLUX HOME PRODUCTS
Consumer Service - EMEA
Quality & Continuous Improvement - Technical Support

	ZRT48202	
	Safety	



- All the work to be performed inside the appliance requires specific skills and knowledge and may only be carried out by qualified and authorised Service Engineers
- Before you access internal components, take the plug out of the socket to disconnect the power supply.
- Some of the components in the mechanical part could cause injuries, so wear suitable protection and proceed with caution.

ZRT48202

General Features

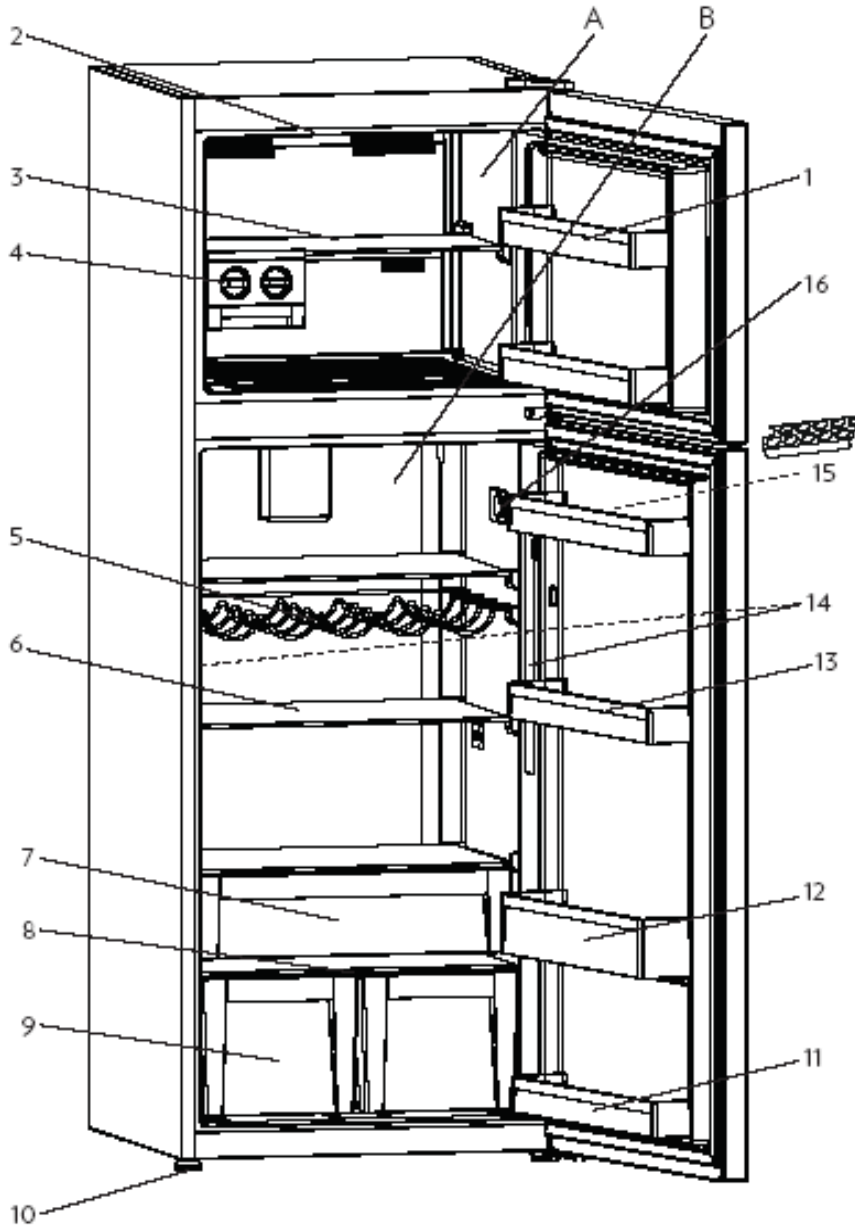

A. Freezer compartment

B. Cooler compartment

1. Freezer compartment door shelf

2. Freezer compartment illumination *

3. Freezer compartment shelf

4. Icematic *

5. Bottle shelf/ Wine shelf *

6. Cooler compartment shelves

7. Chiller (Breakfast) shelf *

8. Crisper cover glass shelf

9. Crisper

10. Adjustable feet

11. Cooler door bottom shelf *

12. Cooler door bottle shelf

13. Cooler door top shelf

14. Cooler compartment illuminations

15. Egg holder/ shelf

16. Thermostat switch

***It is available on some modals.**

	ZRT48202	
	Temperature Setting	

Temperature Setting

The knob in the cooler compartment is used to control the temperature of the freezer and refrigerator compartments automatically. It is represented by “•” and symbolizes the cooling degree between ‘1’ and ‘5’. The cooling degree is increased as long as it is turned ‘1’ to ‘5’ so ‘5’ is max, ‘1’ is min cooling. It might be used at lower level for energy saving during winter months.

Thermostat Knob;

5 (MAX) : For freezing the fresh food fast and obtaining ice fast. Also the cooler compartment reaches to a level of max. cooling. The appliance will work longer. So after you get the maximum cold condition. It should be positioned to previous position when the foods are cool enough.

2 - 3 - 4 : For long-term storage of food in the freezer compartment, you can set the knob medium position for the best performance.

1 (MIN) : For preserving the ice cubes and cold foods and it is used for energy saving on winter season.

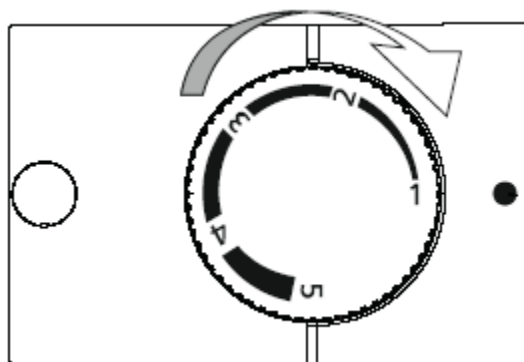

Manual Defrost

- Manual defrost is started when the thermostat position is changed off max-min-max. (in 5 seconds)

- After starting manually, it continues until the end of the defrost process.

	ZRT48202	
	Temperature Setting	

- The pre-set temperature value will not change when the power goes out.
- This refrigerator is designed so as to work at all ambient temperature. Putting foods into the cooler compartment at ambient temperature below -5°C is not recommended because the cooler compartment temperature will be close by the ambient temperature so foods will be frozen. But the foods in the freezer compartment can be preserved even when below -5°C ambient temperature.

Algorithm Operation:

The compressor working schedule depends on some factors such as minimum working time and the defrost sensor. (For example the compressor works minimum 26 minutes after 180 minute's stopping time on thermostat 5 position and it stops working when the defrost sensor feels -35 °C) The working periods are different for each thermostat position from 1 to 5.

- The thermostat value should be chosen according to the frequency of opening-closing the cooler-freezer door, the amount of food being preserved in and the ambient temperature.
- After the refrigerator is plugged in first, it should be worked 24 hours non-stop for cooling totally. Please, do not often open or close the door in the meantime.
- There is a function for protecting the refrigerator when power cut and restore or plugging out-in. Thus, the refrigerator starts working five minutes later.

ZRT48202

Air Flow Diagram

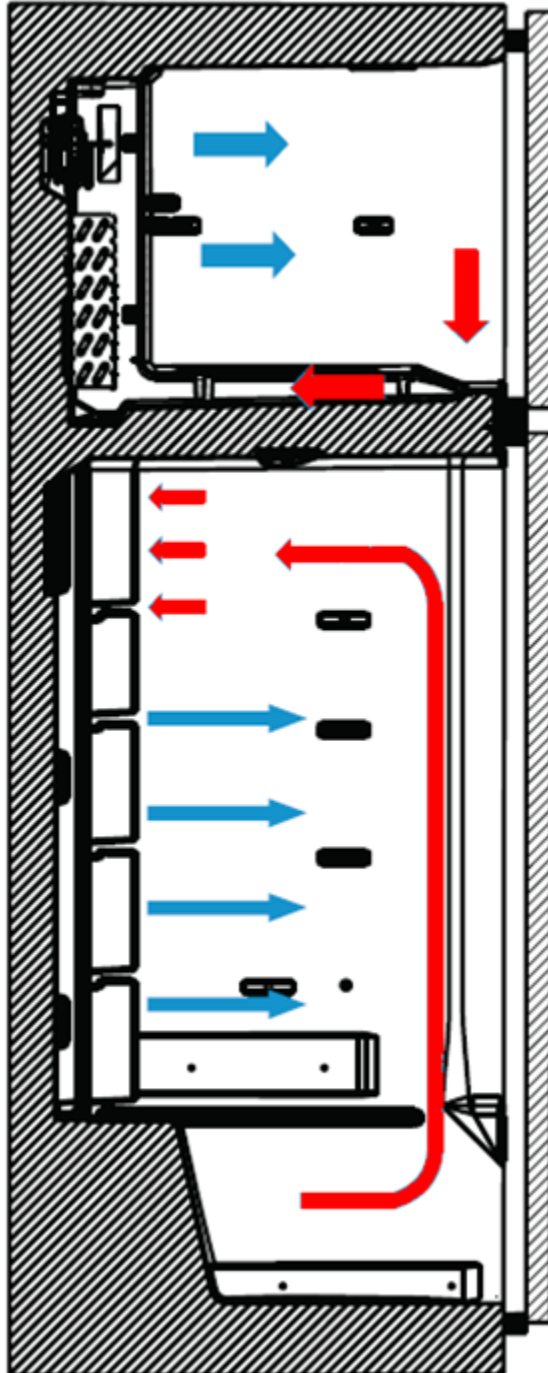

Cutaway view: Air Flow Direction

 **Blown : Cold Air**
 **Returned: Hot Air**

ZRT48202

Air Flow Diagram

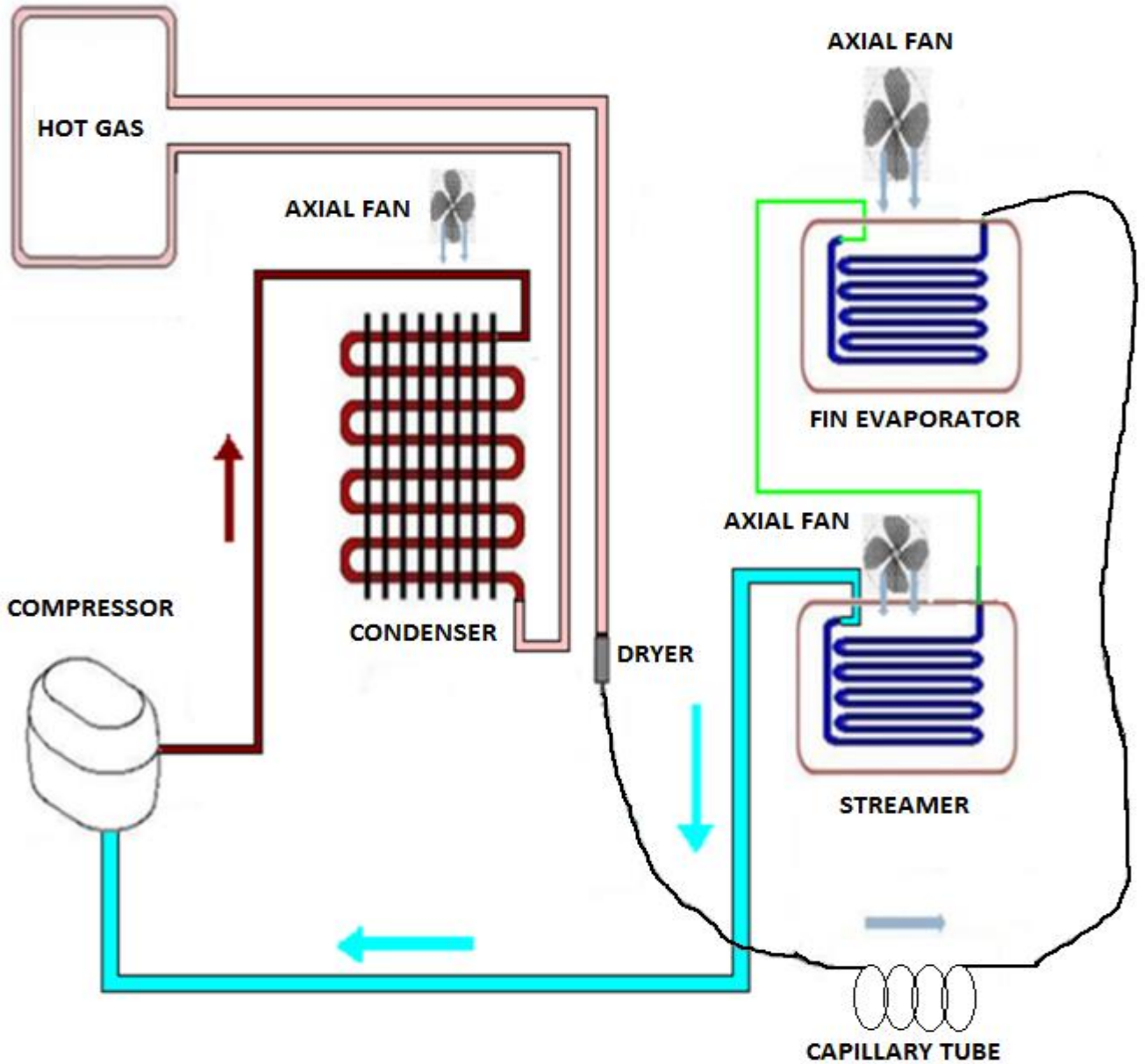

The freezer fan motor and the condenser fan motor work parallel time with the compressor. The freezer fan motor works when the freezer compartment door is opened. It is normal.

The cooler fan motor works parallel time with the compressor. However it could work while the compressor is stopped or the cooler is defrosting.

	ZRT48202	
	Used Component	

- Fin Evaporator Resistance 230V/150W
- Evaporating Tray Resistance 230V/32W (Drain Heater)
- Thermal Fuse 76 °C
- Cooler Defrost Resistance 230V/10W
- Cooler Fan Motor DC 12V
- Evaporator Fan Motor AC 230 V 50 Hz
- Cabin Bottom Fan Motor AC 220 - 240 V 50 Hz
- Mainboard (Power Card) ELECTRONIC(on the right top of rear panel)
- Thermostat Card ELECTRONIC(on right side panel of cooler compartment)
- Freezer Defrost Sensor EPCOS - VISHAY
- Cooler Defrost Sensor EPCOS (it is not possible to change in the body)
- Cooler Sensor EPCOS - VISHAY
- LED Illumination 3.9W
- Transformer On the mainboard

Resistance Values According To The Temperature Sensor (°C/Ohm Rates)
 (For The Freezer Defrost and The Cooler Ambient Sensor)

45 °C/1kΩ	-1 °C/6.2kΩ
35 °C/1.5kΩ	-3 °C/6.8kΩ
30 °C/1.8kΩ	-5 °C/7.5kΩ
25 °C/2.2kΩ	-7 °C/8.2kΩ
19 °C/2.7kΩ	-12 °C/10kΩ
14 °C/3.3kΩ	-15 °C/12kΩ
10 °C/3.9kΩ	-20 °C/15kΩ
5.5 °C/4.7kΩ	-24 °C/18kΩ
1.5 °C/5.6kΩ	-31.5 °C/27kΩ
0 °C/6kΩ	-35.5 °C/33kΩ

Sensor Resistance Values According To The Temperature (°C/Ohm Rates)
 (For The Cooler Defrost Sensor)

45 °C/2.15kΩ	-1 °C/17.1kΩ
35 °C/3.26kΩ	-3 °C/19kΩ
30 °C/4.02kΩ	-5 °C/21.1kΩ
25 °C/5kΩ	-7 °C/23.5kΩ
19 °C/6.53kΩ	-12 °C/30.8kΩ
14 °C/8.23kΩ	-15 °C/36.5kΩ
10 °C/9.95kΩ	-20 °C/48.6kΩ
5.5 °C/12.3kΩ	-24 °C/61.5kΩ
1.5 °C/15kΩ	-31.5 °C/98kΩ
0 °C/16.3kΩ	-35.5 °C/12.6kΩ

	ZRT48202	
	Special Programs	

NTC Sensor

There are three types of sensors. They are cooler, freezer defrost, cooler defrost sensors. Cooler and freezer defrost sensors have the same features but their cable length is different. The resistance values of all sensors decrease when the temperature values of the sensors increase. For example, the resistance value that is 33 kΩ in the -35.5 °C goes down to 1kΩ in the 45 °C and therefore the ambient temperature should be considered while the sensor is being checked. If the ambient temperature is 25 °C, the measuring device shows about 2.2kΩ (if ntc sensor is steady).

When the refrigerator works on first time;

If the cooler compartment defrost sensor and the freezer compartment defrost sensor are hotter than -5°C, the test system works automatically. These below components are tested automatically every 5 seconds.

(If the automatic control process doesn't start initially and started after ten minutes this means one of the sensors are open or short circuit, please check sensors.)

Automatic control steps:

- ❖The compressor starts and stops after 5 seconds.
- ❖The defrost resistance starts and stops after 5 seconds.
- ❖The cooler defrost resistance starts and stops after 5 seconds.
- ❖The DC Radial Fan starts and stops after 5 seconds.

After these steps, the system waits 5 minutes and then it will switch normal mod.

Freezer Defrost Program

- According to the conditions of usage, the defrost might be activated after the min compressor running time; 8 hours or max total time; 55 hours. Below matters are also effected;
- Consisted ice amount,
- Door open-close,
- Sudden usage variance,
- Cooler sudden temperature rise,

Cooler Defrost Program

The cooler defrost and the freezer defrost are operated parallel except those below. If the cooler defrost sensor does not feel 5°C three times during a particular period of time.

- Defrost will be activated after the refrigerator works max 9 hours. According to the conditions of usage, the defrost might be activated (due to mentioned those below) after the compressor works min 5 hours.
- Consisted ice amount,
- Door open-close,
- Sudden usage variance,
- Cooler sudden temperature rise,

	ZRT48202	
	Special Programs	

Freezer Defrosting Time

The Defrost is disabled when the defrost sensor temperature feels 8°C. If defrost time passes 37 minutes, defrost completing temperature will be rise to 15°C.

Cooler Defrosting Time

The cooler defrost and the freezer defrost are operated parallel except those below. The cooler defrost will not work if the freezer defrost stops.

The defrost process stops when the defrost sensor temperature feels 7°C. At the low ambient temperature or when the compressor stops; to balance, defrost stops when the defrost sensor temperature feels 15°C. But if the defrost time or the compressor stopping time goes over 6 hours, the resistance will be stopped.

Compressor delay: First, the defrost process ends, the system waits 5 minutes, just after that the compressor is active.

In Case of Power Cut

- All regulated parameters and functions are kept in memory when the power cut.
- When the electricity comes, if the defrost sensor temperature is lower than -5 °C the compressor works 5 minutes later. If it is higher than -5 °C the compressor works immediately.

Other Features

Warnings : The door open warning is active 2 minutes later and it alarms.

Door Direction : It is possible to reverse the door.

Gasket : It is possible to change the gasket.

	ZRT48202	
	Probable Faults	

Unsufficient cooling	Is the appliance too close to wall or heat sources (stove, central heating, oven, cooker etc.)?	It should be placed min 50cm distance from heat sources and min 5 cm from electrical ovens.
	Is the ambient temperature high?	Raise the thermostat value.
	Check whether putting the hot foods in the refrigerator?	Put the foods after get cold.
	Is there any gas leakage in refrigerant system?	Check all welding points in the system.
The foods in the cooler compartment are freezing.	Were the foods placed close to cooling air outlet?	Please do not block air outlets
	Is the cooler thermostat value high ? Is there any hot foods close to the cooler sensor?	Decrease the cooler thermostat value and do not put hot things close to the sensor.
Are there any sweating or icing?	Were the liquid foods in the closed containers?	Put the liquid foods into the closed containers.
	Were the hot foods put into the refrigerator?	Put it into after getting cold.
	Was the refrigerator door opened?	Do not leave the refrigerator door open and do not often open or close.
Abnormal Noise	Is the appliance on the flat surface?	The floor should be straight and balance the refrigerator with the help of the adjustable feet.
	Is the compressor feet loose	Fix it.
	Is the condenser or fan stationary normal?	Fix it.
	Do the capillary tube or all other tubes touch any where?	Fix it.

	ZRT48202	
	Reversing the door	

1. Hold the top hinge cover and remove it toward that direction (Pic-1)



Picture-1

2. Unscrew the three screws fixing the top hinge and remove it. (Pic-2)



Picture-2

3. Displace the top door (Pic-3)



Picture-3

4. Unscrew the two screws fixing the middle hinge and remove it. (Pic-4)



Picture-4

	ZRT48202	
	Reversing the door	

5. Displace the bottom door. (Pic-5)



Picture-5

6. Unscrew the adjustable foot (Pic-6)



Picture-6

7. Unscrew the bottom hinge screws. (Pic-7)



Picture-7

	ZRT48202	
	Reversing the door	

8. Unscrew the bottom hinge pin and screw it to other hole. (Pic-8)

9. Unscrew the left bottom adjustable foot and the screws fixing roller. After that screw them to other side (Pic-9)



Picture-8



Picture-9

10. Screw the bottom hinge to the left bottom side of refrigerator. Screw the adjustable foot there. (Pic-10)

11. Unscrew the two screws fixing stopper and stopper support plate under the cooler door. After that screw the other side. (Pic-11)



Picture-10



Picture-11

	ZRT48202	
	Reversing the door	

12. Replace the top bushing and the top bushing cap at the bottom door. (Pic-12)



Picture-12

13. Remove the catcher under the top door and then stopper reinforcement plate. (Pic-13.1) First, screw stopper support plate the closest one to bigger hole. Second, screw stopper without using a cordless screwdriver. (Pic-13.2)



Picture-13.1



Picture-13.2

14. Remove the hinge cover on the top panel and replace to other side.(Pic-14)



Picture-14

	ZRT48202	
	Reversing the door	

15. Remove the middle hinge cover and then screw the screw on the side panel (Pic-15.1) and assemble to the right side panel (Pic-15.2)



Picture-15.1

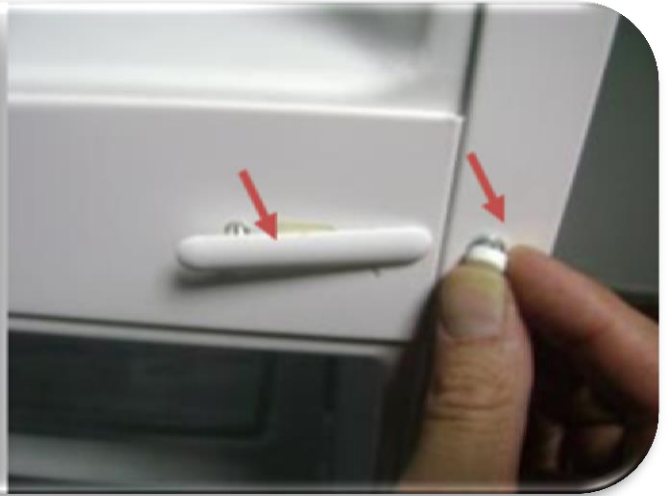

Picture-15.2

16. Place the bottom door (Pic-16.1) and rotate the middle hinge by 180°. After that, screw to the right side on the middle sheet. (Pic-16.2)



Picture-16.1



Picture-16.2

	ZRT48202	
	Reversing the door	

17. Place the top door to the middle hinge and then screw the top hinge to the top panel.
(Pic-17)

18. Place the top hinge cover. (Pic-18)



Picture-17



Picture-18

	ZRT48202	
	Removing and Chancing The Mainboard	

CAUTION: The plug must be pulled out before the mainboard group is removed.

1. Unscrew the three screws which are fixing the mainboard cover by using the screwdriver. (Pic-1 / Pic-2 / Pic-3)
2. Remove the cover after the screws are removed.(Pic-4)



Picture-1



Picture-2

3. Pull the mainboard slightly forward and disconnect all the connectors and then replace it. Finally, place the mainboard cover and screw it.



Picture-3



Picture-4

	ZRT48202	
	Removing The Thermostat Group	

1. Stick a short tape above the thermostat box as in the Pic-1.

It protects from scratching the thermostat box. Remove the screw cap with the help of a flat screwdriver (if it's possible) .



Picture-1

2. Unscrew the screw. (Pic-2)



Picture-2

3. First, pull the rear side and remove the front side. (Pic-3)



Picture-3

4. Disconnect the cable fixing board by pressing the socket latch. (Pic-4)



Picture-4

	ZRT48202	
	Removing The Thermostat Group	

5. Unscrew the screws on the board and remove the board. (Pic-5)



Picture-5

6. Flex the housing of the thermostat knob and remove it. (Pic-6)



Picture-6

	ZRT48202	
	Removing- Assembling LEDs and LED's Covers	

- 1.** Stick a tape to protect plastic. Insert a flat screwdriver into the gap and remove the cover. (Pic-1)



Picture-1

- 2.** Remove the led strip light from its housing. (Pic-2)



Picture-2

- 3.** Disconnect the connector and change the led light strip. (Pic-3)

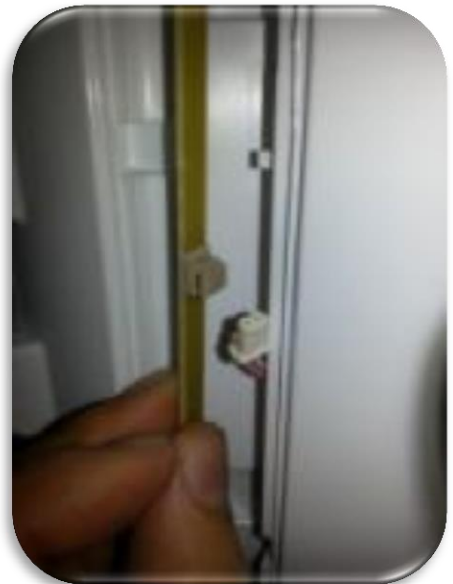

Picture-3

	ZRT48202	
	Removing- Assembling LEDs and LED's Covers	

4. First, place the bottom point of the led light strip and then place towards other side.(Pic-4)



Picture-4

5. Reassemble the led cover. (Pic-5)



Picture-5

ZRT48202

Removing The Cooler Multi Flow

1. Remove the cooler glass shelves and the chiller. (Pic-1/ Pic-2/Pic-3)



Picture-1



Picture-2



Picture-3

2. Stick one tape to each air duct to avoid scratching. Remove the screw caps by using a flat screwdriver and screw the screws. (Pic-4)



Picture-4

3. Flex the multi flow by holding the fan cover and remove it. Disconnect the connector after removing the multi flow. (Pic-5)



Picture-5

	ZRT48202	
	Removing The Cooler Multi Flow Fan Motor	

1. Remove the fan cover by flexing the fan cover detail and then remove the fan motor by flexing the fan motor rubbers. (Pic-1/ Pic-2/Pic-3)



Picture-1



Picture-2



Picture-3

2. Place the rubbers to the fan motor. After that, first place the bottom two details of the fan motor and place the top two details by pressing-flexing it. (Pic-4/ Pic-5/Pic-6)

Note : The fan motor cable outlet should be at the top-left corner of it.

3. After the connector is connected, place it by flexing it and then reassemble the multi flow by screwing.



Picture-4



Picture-5



Picture-6

ZRT48202

Removing The Freezer Multi Flow Group

1. Displace the glass shelf or the ice box group if there is. (Pic-1)
2. Insert a flat screwdriver into the gap and then support the lateral surface of the multi flow with the help of a hand and remove the freezer multi flow group. (Pic-2)
3. Removing the freezer bottom cover by flexing back side of it. (Pic-3)



Picture-1



Picture-2



Picture-3

Assembling The Freezer Multi Flow Group

1. Recline the bottom cover against one side and place the freezer multi flow cover details. (Pic-4)
2. Hold the back side of the bottom cover and flex it. After that, reassemble the other side details. Finish the assembly by pulling the cover. (Pic-5 / Pic-6)
3. First, place the freezer multi flow details to the backside of the bottom cover (Pic-7/Pic-8) and reassemble the freezer multi flow cover by pushing back. (Pic-9)

Note: The freezer multi flow should be removed before the freezer bottom cover.



Picture-4



Picture-5



Picture-6



Picture-7



Picture-8



Picture-9

CAUTION: The plug must be pulled out before the mainboard group is removed.

1. Remove the putty around the freezer defrost sensor. (Pic-1)



Picture-1

2. Disconnect the sensor connector. (Pic-2)



Picture-2

3. Assemble the new sensor to the evaporator resistance as shown in the picture. (Pic-3)

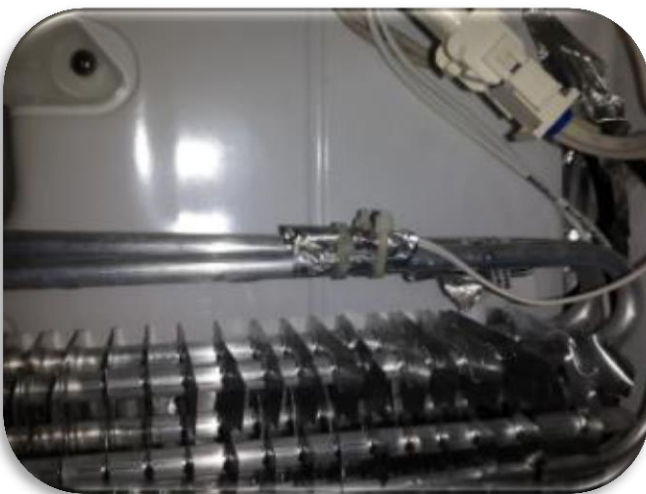

Picture-3

4. Connect the sensor socket and apply putty. (Pic-4)



Picture-4

	ZRT48202	
	Changing The Cooler Sensor	

1. Remove the sensor cover with the help of a screwdriver and then disconnect the sensor connector. (Pic-1)

2. Place the bottom-front details of the cover to its housing and then place the top cover detail to the housing by flexing it with a screwdriver. (Pic-2)



Picture-1



Picture-2

CAUTION: Pay attention not to damage to the sensor cover details!

ZRT48202

Removing Fin Evaporator Group

1. Remove the fin evaporator resistance connectors from the sockets. (Pic-1) (**blue** connector)



Picture-1

2. Displace the fin evaporator balanced by holding on both sides. (Pic-2)

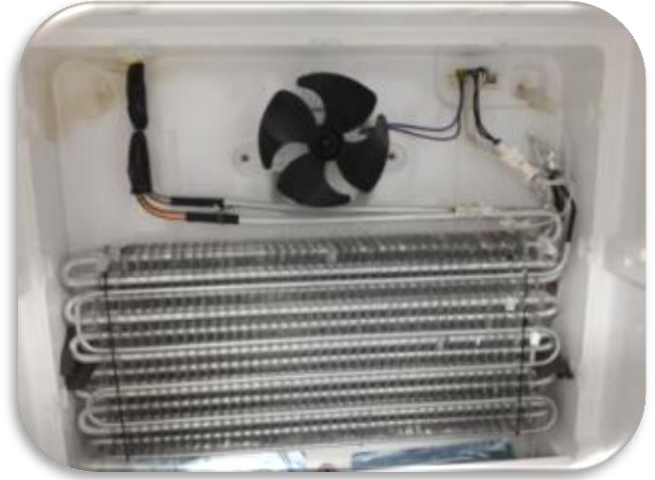

Picture-2

CAUTION: The fin evaporator should not be pulled upward-downward. Otherwise, the fin evaporator fixing plastics might be broken.

Removing The Thermal Fuse

1. Remove the thermal fuse connector. (Pic-1) (**black** connector)

2. Cut the thermal fuse cable tie at right side of the fin evaporator group and take the thermal fuse out. (Pic-2)

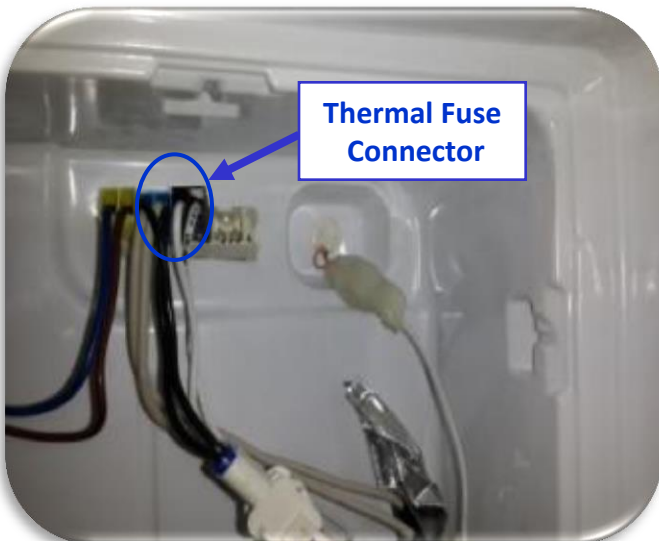

Picture-1

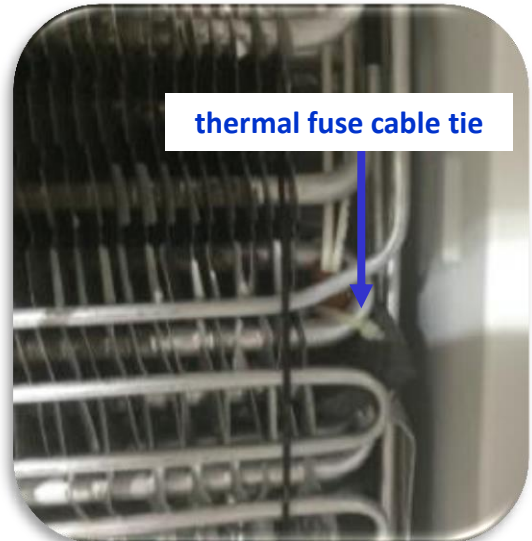

Picture-2

	ZRT48202	
	Removing The Freezer Fan Motor	

1. Remove the fan motor connector. (Pic-1)
2. Unscrew the fan motor fixing screws and displace the fan motor. (Pic-2)
3. Remove the propeller. (Pic-3)



Picture-1



Picture-2



Picture-3

4. Displace the details on the fan motor box. (Pic-4)



Picture-4



Fan Motor Components

ZRT48202

Removing The Evaporating Tray and The Bottom Cab Fan Motor

1. Unscrew the bottom tray screws and displace it from the compressor basement. After that, remove the fan motor connector. (Pic-1)
2. Unscrew the screws fixing the evaporating tray. (Pic-2)
3. Remove the evaporating tray to displace the fan motor. (Pic-3)



Picture-1



Picture-2



Picture-3

4. Unscrew the fan motor screws. (Pic-4)
5. Remove the propeller. (Pic-5,Pic-6)



Picture-4



Picture-5



Picture-6

	ZRT48202	
	Removing/Assembling The Door Switch	

1. Stick a tape to protect the body plastic. Flex it with the help of a tool like a slotted screwdriver. (Pic-1)



Picture-1

2. Also flex the top-side of the switch and then displace by pulling. (Pic-2)



Picture-2

3. Put the switch connector cable in the housing. First place the top-side of the switch and then push the bottom side.(Pic-3.1/Pic-3.2)



Picture-3.1



Picture-3.2

4. After the switch is placed, complete the assembly by pushing. (Pic-4)



Picture-4.1



Picture-4.2

CAUTION: The bottom-top details of the switch are different from each other to avoid assembling wrong!

ZRT48202

Electricity Diagram

The Freezer Compartment Light

The Cooler Compartment Left Light

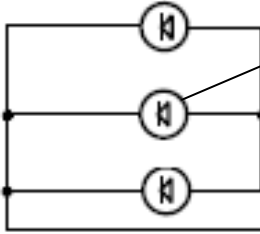

The Cooler Compartment Right Light

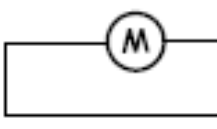

The Cooler Compartment Fan

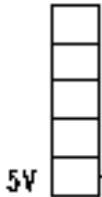
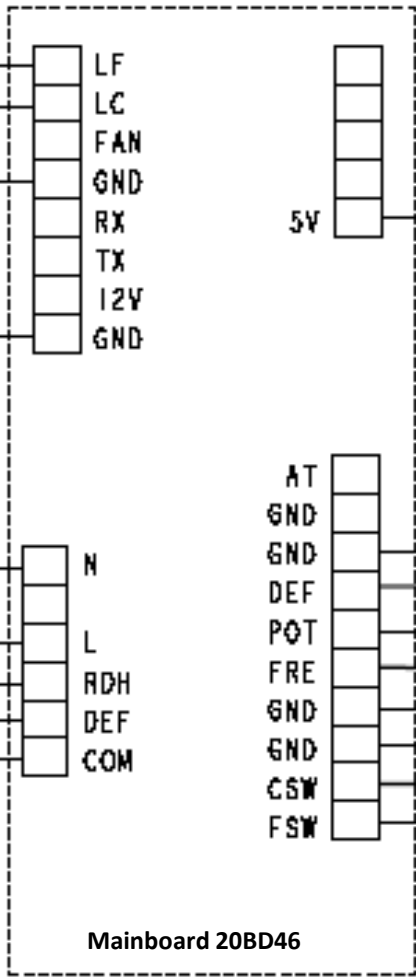

Thermostat



Defrost Sensor

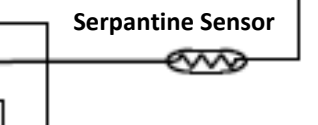
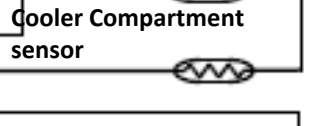
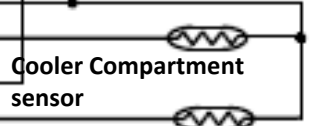

Cooler Door

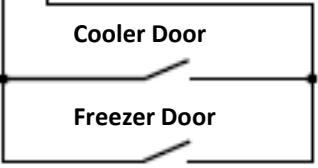

Freezer Door

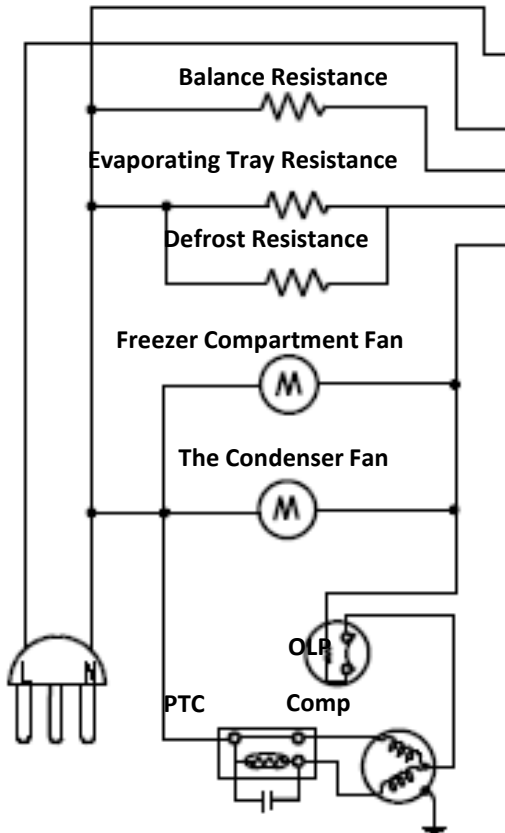

Capacitor (Optional)