



**NOISY APPLIANCE/ INTERFERENCE BETWEEN LOWER SPRAY ARM AND ASCENDING PIPE**

**DESCRIPTION:**

Some dishwashers from new Global Hydraulic platform produced in Żarów (PLV) make a regular knocking noise. It concerns appliances produced till week **47/2014**. Slight inclination of lower spray arm's support cause tilting spray arm back and in consequence collision with ascending pipe.

**SOLUTION:**

To solve the problem is necessary to replace the lower spray arm support by the new one with code **1119158176**.

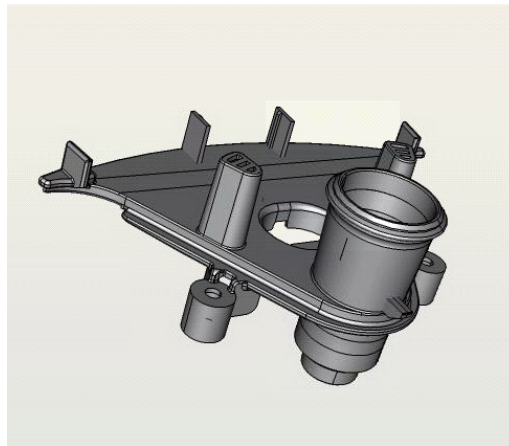

**SPARE PART NUMBER:**

Old spare part code	New spare part code	Description
111915811/9	111915817/6	Lower spray arm support
111915813/5		Lower spray arm support

**MODELS INVOLVED:**

PNC	Model
911513099	ZDF14001WA
911513100	ZDF14001WA
911513101	ZDF1010
911513102	ZDF14001KA
911513103	ZDF14001XA
911513104	ZDF14001SA
911513105	ZDF14002WA
911513106	ZDF14003WA
911513107	F45502W0
911513109	ZDF14001XA
911513110	ZDF91400XA
911513111	ZDF91400WA
911513132	DSF6205W
911513133	DSF6205X
911516109	ZDF14011WA
911516110	ZDF14011WA
911516111	ZDF14021WA
911516112	ZDF14011XA
911516113	ZDF14011XA
911516114	ZDF16001WA
911516115	FDf16001WA
911516117	ZDF16021WA
911516118	FDf16021WA
911516119	ZDF16021XA
911516121	ZDF18001WA
911516122	PDF18001WA
911516123	ZDF18001XA
911516124	ZDF18001XA
911516125	PDF18001XA
911516126	ZDF18011WA
911516127	FDf18011WA
911516128	FDf18011XA
911516129	FDf16021SA
911516132	FDf16004WD
911516134	FDf16026SB
911516136	F55519W0
911516137	F55529W0
911516138	F55502W0
911516139	F55500W0
911516140	F55500M0
911516141	F55502W0
911516142	F55500M0
911516143	F55512W0
911516144	F55512M0
911516145	F55522W0
911516146	F55522M0
911516147	ESF6511LOW
911516148	ESF6511LOX

PNC	Model
911524017	F56512IW0
911524018	F56512UD0
911524019	F56512UM0
911524020	F56512UW0
911524021	F56529IM0
911524022	F56529IW0
911524023	F56529ID0
911524024	F56529UM0
911524025	F56529UW0
911524026	F56529UD0
911524027	F56509IM0
911524028	F56509UM0
911524029	F56512ID0
911524030	F56528IM0
911524031	F55310IM0
911524032	F55320IM0
911524033	F56302IM0
911524034	F56309UM0
911524035	F56312IM0
911524036	F56312UM0
911524037	F56312IW0
911524038	F56312UW0
911524039	F56312ID0
911524040	F56312UD0
911524041	F56329IW0
911524042	F56329UW0
911524043	F56329ID0
911524044	F56329UD0
911524045	F56329IM0
911524046	F56329UM0
911524047	F56309IM0
911524048	F56302UM0
911524049	F56322IM0
911526056	ZDI16010XA
911526057	ZDI16013XA
911526058	ZDI16015XA
911526059	ZDI16016XA
911526064	ESi6501LOW
911526065	ESi6501LOX
911526066	ESi6501LOK
911526067	ESi6511LOW
911526068	ESi6511LOK
911526069	ESi6511LOX
911526070	ESi6521LOX
911526071	ESi6521LOK
911526072	ESi6531LOX
911526073	ESi6531LOK
911526074	ESi6501LAK

PNC	Model
911536071	TT792
911536072	QB6061I
911536073	VA61111MT/A00
911536074	F55505VI0
911536075	F55512VI0
911536076	ESL6551LO
911536077	ESL6561LO
911536078	TT702
911536079	F55524VI0
911536081	F55533VI0
911536082	F55310VI0
911536083	F55320VI0
911536085	ZDT26001FA
911536086	ZDT26002FA
911536087	ZDT92600FA
911536088	ZDT26010FA
911536089	ZDT26010FA
911536090	ZDT26020FA
911536091	ESL5310LO
911536092	ESL5310LO
911536093	ESL9531LO
911536094	ESL5320LO
911536095	ESL5330LO
911536096	ESL95330LO
911536097	ESL5340LO
911536098	F55300VI0
911536099	F55301VI0
911536100	F55302VI0
911536101	F55311VI0
911536102	F55312VI0
911536103	F55320VI0
911536104	F55330VI0
911536105	F55331VI0
911536106	F55340VI0
911536107	ESL70001
911536108	QB6062I
911536109	RDT26001FA
911536110	FDT26001FA
911536111	ESL5349LO
911536112	F95533VI0
911536113	SKINANDE
911536114	SKINANDE
911536115	SKINANDE
911536116	F55322VI0
911536117	ESL5310LO
911536118	JGVN60525
911536119	VA61211MT/A01
911536120	SKINANDE

PNC	Model
911516149	ESF6519LOW
911516150	ESF6515LOW
911516151	ESF6512LGX
911516152	ESF6515LOX
911516153	ESF6521LOX
911516154	ESF6521LOW
911516155	ESF6501LOW
911516156	F55512W0
911516157	ESF6535LOX
911516158	ESF6535LOW
911516159	ZDF4014
911516160	ZDF18001XA
911516161	ESF76511LX
911516162	F55500W0
911516163	RSF6511LOW
911516164	RSF6521LOW
911516165	RSF6511LOK
911516166	RSF6511LOX
911516167	RSF6521LOX
911516168	ESF6528LZW
911516169	ESF6528LZX
911516170	DSF6305W
911516171	DSF6305X
911516172	ESF6525LOW
911516173	ESF6525LOX
911516174	ESF6531LOW
911516175	ESF6531LOX
911516176	RSF6531LOW
911516177	RSF6531LOX
911516178	F55513W0
911516179	F55513M0
911516180	KDF60002WE
911516181	KDF60012WE
911516182	ZDF26001WA
911516183	ZDF26001WA
911516184	ZDF26002WA
911516185	ZDF92600WA
911516186	ZDF26001XA
911516187	ZDF26001XA
911516188	ZDF26002XA
911516189	ZDF92600XA
911516190	ZDF26011WA
911516191	ZDF26011WA
911516192	ZDF26011XA
911516193	ZDF26011XA
911516194	ESF5511LOW
911516195	ESF9551LOW
911516196	ESF5511LOX
911516197	ESF75511LX
911516198	ESF9551LOX
911516199	ESF5521LOW

PNC	Model
911526075	ESI6501LAW
911526076	ESI6501LAX
911526082	ESI6516LAX
911526086	ESI6541LOW
911526087	ESI6541LOX
911526088	ESI6541LOK
911526089	ESI6521LOW
911526090	ZDU16013XA
911526091	ESI6501LOX
911526092	KDI61000XA
911526093	KDU61000XA
911526097	ESI6541LAW
911526098	ESI6541LAX
911526099	ESI6541LAK
911526100	ESI76511LX
911526101	ESI6542LOW
911526102	ESI6542LOX
911526103	ESI6542LOK
911526104	ESI6542LAW
911526105	ESI6542LAX
911526106	ESI6542LAK
911526107	ESI6531LOW
911526109	KDI60010WA
911526110	KDU60010XA
911526111	KDU61010XA
911526112	KDI60010DA
911526113	KDI61010XA
911526114	KDI60010XA
911526115	PI3570X
911526117	ZDI26001XA
911526118	ZDI26010XA
911526119	ZDU26010XA
911526120	ESI5510LAW
911526121	ESI5510LAK
911526122	ESI5510LAX
911526123	ESI5530LOW
911526124	ESI5530LOX
911526125	ESI5530LOK
911526126	ESI5540LOW
911526127	ESI5540LOX
911526128	ESI5540LOK
911526129	JGIN60415
911526130	VA63211RF/A01
911526131	RSI5511LOX
911526132	RSI5511LOK
911526133	RSI5511LOW
911526134	FDI26010XA
911526135	FDI26010WA
911526136	FDI26010NA
911529126	LI1320X
911529127	ZDI12010XA

PNC	Model
911536121	TT703L3
911536122	RSL5531LO
911539097	LV1520
911539098	PV1540
911539099	KDT11002FK
911539100	PDT11002FK
911539101	PDT10002FK
911539102	KDT10001FB
911539103	ZDT12011FA
911539104	LAGAN
911539105	LAGAN
911539106	LAGAN
911539107	ZDT12011FA
911539108	ZDT13012FA
911539109	ZDT13012FA
911539110	ESL6201LO
911539111	ESL6211LO
911539112	F34500VI0
911539113	F34502VI0
911539114	F34502VI0
911539115	ESL6201LO
911539116	ESL6211LO
911539117	IDSH602W
911539118	GVW581ONY/P00
911539119	TT392
911539122	TT301
911539123	ESL76211LO
911539124	ESL96211LO
911539125	ZDT91301FA
911539126	ZDT12041FA
911539127	VA61111KT/A00
911539128	TT403
911539129	IGV6504.1-CN
911539130	ZDT12051FA
911539131	ZDT12041FA
911539132	ZDT13010FA
911539133	F34300VI0
911539135	ZDT21001FA
911539136	ZDT21001FA
911539137	ZDT92100FA
911539138	ZDT22001FA
911539139	ESL5201LO
911539140	ESL5201LO
911539141	ESL95201LO
911539142	ZDT92200FA
911539143	ZDT21002FA
911539144	ZDT21003FA
911539145	ZDT21004FA
911539146	LAGAN
911539147	LAGAN
911539148	LAGAN

PNC	Model
911516200	ESF5521LOX
911516201	ESF5531LOW
911516202	ESF5531LOW
911516203	ESF5531LOX
911516204	ESF5531LOX
911516205	ESF5541LOW
911516206	ESF5541LOX
911516207	F56302W0
911516208	F56303W0
911516209	F56304W0
911516210	F56302W0
911516211	F56309W0
911516212	F56302M0
911516213	F56302M0
911516214	F56312W0
911516215	F56312W0
911516216	F95631W0
911516217	F56312M0
911516218	F95631M0
911516219	F56322W0
911516220	F56329W0
911516221	F56322M0
911516222	ESF5511LOX
911516223	ZDF4015
911516224	RSF5511LOX
911516225	RSF5531LOX
911516226	RSF5511LOW
911516227	RSF5531LOW
911519146	ZDF11001WA
911519147	PDF11001WA
911519148	ZDF11001WA
911519149	ZDF11002WA
911519150	ZDF12001WA
911519151	PDF12001WA
911519152	ZDF12002WA
911519153	ZDF12001XA
911519154	ZDF12001XA
911519155	ZDF12001SA
911519157	ZDF13001WA
911519158	ZDF13001WA
911519163	PDF12001KA
911519164	PDF12001XA
911519165	ESF6201LOW
911519168	ESF6211LOW
911519169	ESF6211LOX
911519170	ZDF12001WA
911519171	ZDF12001XA
911519178	ZDF91300WA
911519179	ZDF91200WA
911519181	DSF6105W
911519182	DSF6105X

PNC	Model
911529128	ZDI12010WA
911529129	PI1320X
911529130	PI1540X
911529131	KDI11002XK
911529132	ZDU12010XA
911529133	PDI10002XK
911529134	PDI11002XK
911529135	KDI10001XB
911529136	KDI10001XK
911529137	ZDI12010XA
911529138	ZDI13010XA
911529139	ZDI13010WA
911529140	ZDI13010NA
911529141	ZDI12010DA
911529142	ESI6201LOX
911529143	F34500IM0
911529144	PI1320XC
911529145	TP612N
911529146	TP612X
911529147	ESI9620LOX
911529148	ESI76201LX
911529149	ZDI6502X
911529150	IG6504.1E-CN
911529151	F34300IM0
911529152	ZDI22001XA
911529153	ZDI22001XA
911529154	ZDI6503X
911529155	ESI5201LOX
911529156	ESI5201LOX
911529157	ESI5211LOX
911529158	ESI5201LOX
911529159	JGin60315
911529160	TP703L3X
911529161	FDI22001XA
911529162	FDI22001NA
911529163	FDI22001WA
911535055	ZDT15010FA
911535056	RENGÖRA
911535057	RENGÖRA
911535058	RENGÖRA
911535059	ZDT15010FA
911535062	ESL6301LO
911535064	TT603
911535065	PV3565
911535067	ZDT24001FA
911535068	ZDT24001FA
911535069	ZDT24002FA
911535070	ZDT92400FA
911535071	ESL5301LO
911535072	RENGÖRA
911535073	RENGÖRA

PNC	Model
911539149	VA61211KT/A01
911539150	GVW571ONY/P01
911539151	LAGAN
911539152	RSL5202LO
911539153	RSL5211LO
911539154	RSL5203LO
911539155	TT403L3
911539156	FDT22001FA
911543048	F45500W0
911546034	DI9127
911546035	ZDF14011WA
911546036	DI9127X
911546037	ZDF14011XA
911546038	RW6500
911546039	RW6500X
911546040	F55502W0
911546041	QB6046W
911546042	F55502M0
911546043	F55520W0
911546045	F55520M0
911546047	QB6051W
911546048	ESF6512LOW
911546049	ESF6512LOX
911546050	ESF6536LJX
911546056	ESF7000X
911546057	ESF6539LFX
911546058	ESF7000W
911546059	ESF6539LFW
911546060	ESF6536LJW
911546062	QB6051X
911546063	ESF6531LOW
911546064	ESF6531LOX
911546065	ZDF26011WA
911546066	ZDF26011XA
911546067	ESF5510LIW
911546068	ESF5510LIX
911546069	ESF5521LOX
911546071	ESF5541LHW
911546073	ESF5521LOW
911546074	F56312W0
911546075	F56312M0
911546076	F56322W0
911546077	F56322M0
911546078	DI9128
911546079	RW6501
911546080	DI9128X
911546081	RW6501X
911546083	ESF7000W1
911546084	ESF7000X1
911546085	QB6047W
911546086	QB6052W

PNC	Model
911519183	SSF6105W
911519184	SSF6105X
911519185	ZDF23001WA
911519186	ZDF1011
911519187	ZDF92300WA
911519188	ZDF92300XA
911519189	ZDF21001WA
911519190	ZDF21001WA
911519191	ZDF21001XA
911519192	ZDF21001XA
911519193	ZDF21001NA
911519194	ESF5201LOW
911519195	ESF9520LOW
911519196	ESF5201LOX
911519197	ESF9520LOX
911519198	ESF5201LOW
911519199	FDF23001WA
911519200	FDFE12GFAW6
911519201	FDFE12GFAS6
911519202	RSF5202LOW
911519203	RSF5202LOX
911519204	RSF5203LOW
911523057	F50502IW0
911523058	F50502ID0
911523059	F50502IM0
911523060	F50502UM0
911523061	F55502IM0
911524013	F55500IM0
911524014	F55510IM0
911524015	F56512ID0
911524016	F56512IM0

PNC	Model
911535074	RENGÖRA
911535075	JGVN60415
911535076	ZDT25001FA
911535077	RENGÖRA
911535078	TT603L3
911536043	ZDT16015FA
911536044	ZDT16012FA
911536045	ZDT16013FA
911536046	ZDT16016FA
911536047	SKINANDE
911536048	SKINANDE
911536049	SKINANDE
911536050	RDT16012FA
911536051	ESL6352LO
911536052	ESL6356LO
911536053	ESL6361LO
911536054	ESL6362LO
911536055	F54500VI0
911536056	F55500VI0
911536057	F55510VI0
911536058	F50502VI0
911536059	F55502VI0
911536060	F55522VI0
911536061	F55502VI0
911536062	ESL6356LO
911536064	ESL7000
911536065	ZDT16017FA
911536066	ESL6541LO
911536067	ESL76356LO
911536069	ESL96361LO
911536070	ZDT91601FA

PNC	Model
911546087	QB6052X
911546088	F56302M0
911546089	F56302W0
911546090	ESF5511LOW
911546091	ESF5511LOX
911546092	ESF5510LKW
911549055	DI8507
911549056	RW4500
911549057	ZDF11001WA
911549058	DI8517
911549059	RW4510
911549060	ZDF12001WA
911549061	DI8517X
911549062	ZDF12001XA
911549063	ESF6212LOW
911549064	ESF6212LOX
911549065	ESF6211LHW
911549066	ESF6211LIW
911549067	ZDF23001WA
911549068	ZDF21001WA
911549069	ZDF23001XA
911549070	ESF5201LOW
911549071	ESF5201LOX
911549072	DI8518
911549073	RW4511
911549074	DI8508
911549075	RW4501
911549076	DI8518X
911549077	ESF5200LIW

**REVISION:**

Revision	Date	Description	Author	Approved by - on
01	02/2015	Spare part code update	Marcin Łapa	Krzysztof Dobrzański
00	10/2014	Document Creation	Marcin Łapa	Krzysztof Dobrzański