

© ELECTROLUX HOME PRODUCTS  
Customer Care - EMEA  
Training and Operations Support  
Technical Support

Publication  
number

**599 77 39-04**

EN

**QB70  
Automatic  
Washer**



## **SPECIFICATION**

<b>Power source</b>	<b>AC 230-240V, 50Hz</b>
<b>Overall dimension(Net dimension)</b>	<b>570(W) × 587(D) × 950(H)</b>
<b>Net weight</b>	<b>36kg</b>
<b>Power consumption</b>	<b>400W</b>
<b>Motor output</b>	<b>180W</b>
<b>Marked capacity of washing/spinning</b>	<b>9.0kg</b>
<b>Washing method</b>	<b>Automatic reverse turn</b>
<b>Water capacity</b>	<b>60 Liters</b>
<b>Water consumption</b>	<b>138 Liters (Regular wash cycle Water level: High)</b>
<b>Pulsator speed</b>	<b>170 rpm(DELICATE 60 rpm)</b>
<b>Spinner tub speed</b>	<b>850 rpm</b>

**Specification: Subject to change without notice.**

## ABNORMAL CONDITION

When the washer is abnormal, the washer stops as the every actions turns off, beep tone sounds ON-0.1 second and OFF-0.1 second for 6 seconds and number window LED display abnormal code. The washer judges the following six conditions as abnormal condition.

1) Abnormal condition of water supply

In supplying with water, the water level does not reach extra low level within 10 minutes or does not reach your chosen water level within 20 minutes.

The number window LED display abnormal code: **E1** and the electric buzzer sounds to indicate a problem at the same time.

2) Abnormal condition of drain

In draining, the water level does not go down below the reset level of the water level sensor within 8 minutes.

The number window LED display abnormal code: **E2** and the electric buzzer sounds to indicate a problem at the same time.

3) Abnormal condition of spin-dry

- The safety switch works 3 times continuously during the program of rinse-spin or works 1 time in the single program of spin-dry.

The number window LED display abnormal code: **E3** and the electric buzzer sounds to indicate a problem at the same time.

- The washer lid is opened.

The number window LED display abnormal code: **E4** and the electric buzzer sounds to indicate a problem at the same time.

4) Abnormal condition of child lock.

Running in setting child lock, the washer lid is opened beyond 4 seconds.

The number window LED display abnormal code: **E5** and the electric buzzer sounds to indicate a problem at the same time.

5) Abnormal condition of water level sensor.

The water level sensor malfunctions or the water level is overrunning the alert level when the water does not stop.

The number window LED display abnormal code: **E6** and the electric buzzer sounds to indicate a problem at the same time.

6) Abnormal condition of load sensor.

The number window LED display abnormal code: **E7** and the electric buzzer sounds to indicate a problem at the same time.

## CIRCUIT DIAGRAM

COLOR SYMBOL	
Gr	GRAY
Bl	BLUE
G	GREEN
B	BLACK
LB	LIGHT BLUE
Br	BROWN
O	ORANGE
P	PINK
R	RED
W	WHITE
Y	YELLOW
V	VIOLET

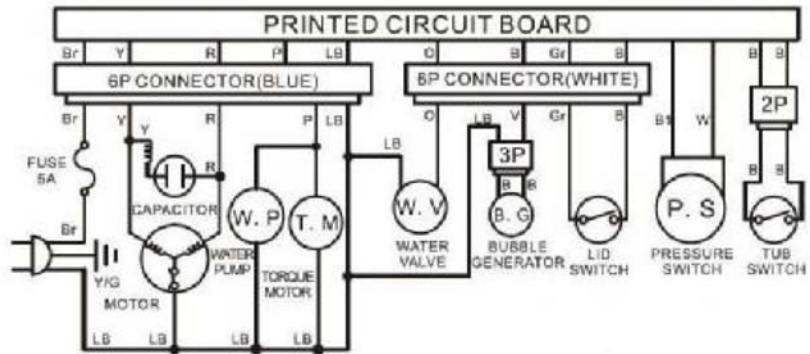

## TROUBLE SHOOTING

TROUBLE	INSPECTION	CAUSES	REMEDY
---------	------------	--------	--------

### a. Power Source

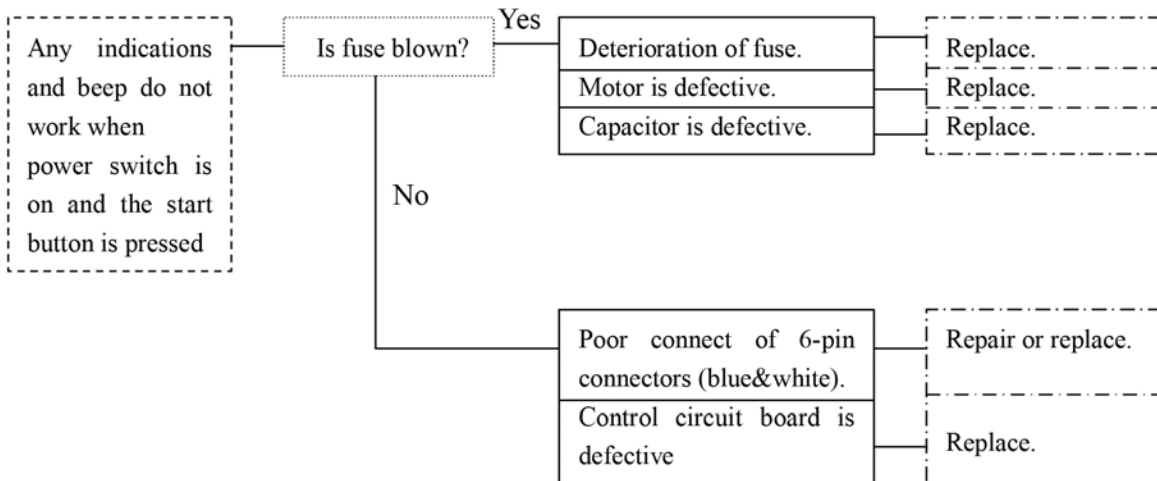

TROUBLE	INSPECTION	CAUSES	REMEDY
---------	------------	--------	--------

b. Water Supply

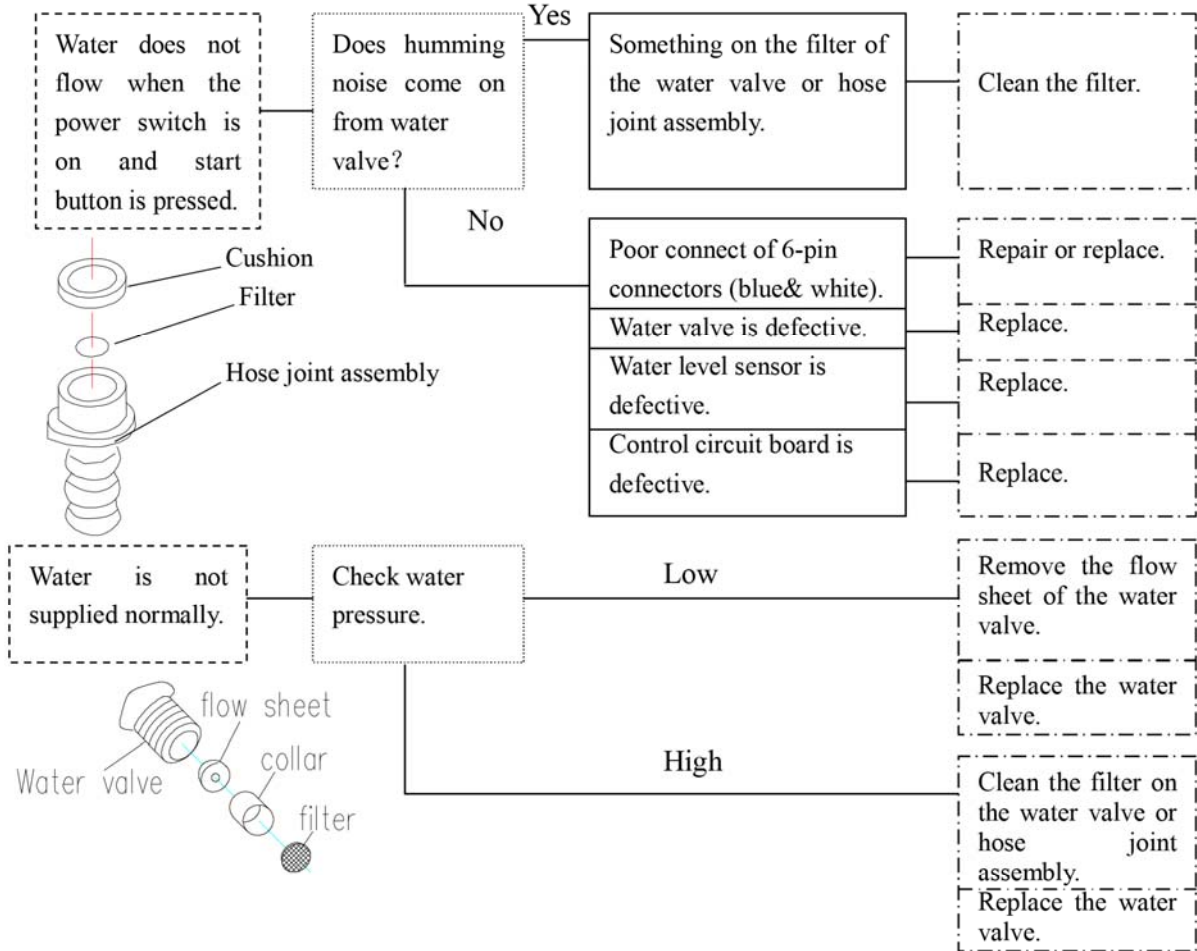

**Note: When removing the flow sheet, reinstate the filter in place correctly.**

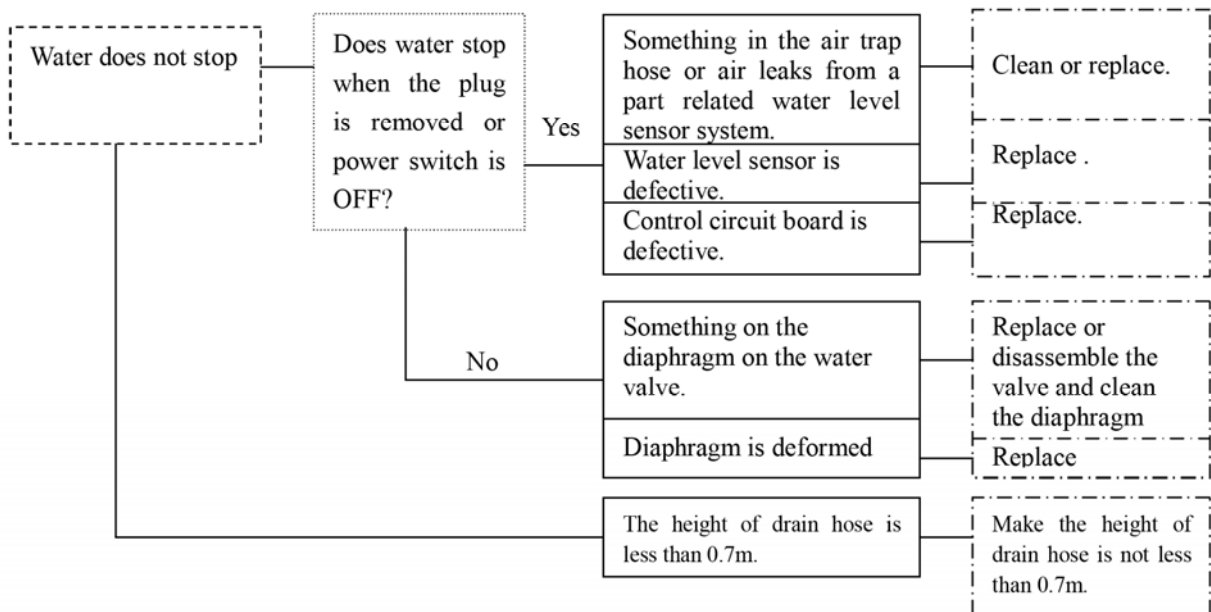

TROUBLE	INSPECTION	CAUSES	REMEDY
---------	------------	--------	--------

c. Wash/Rinse

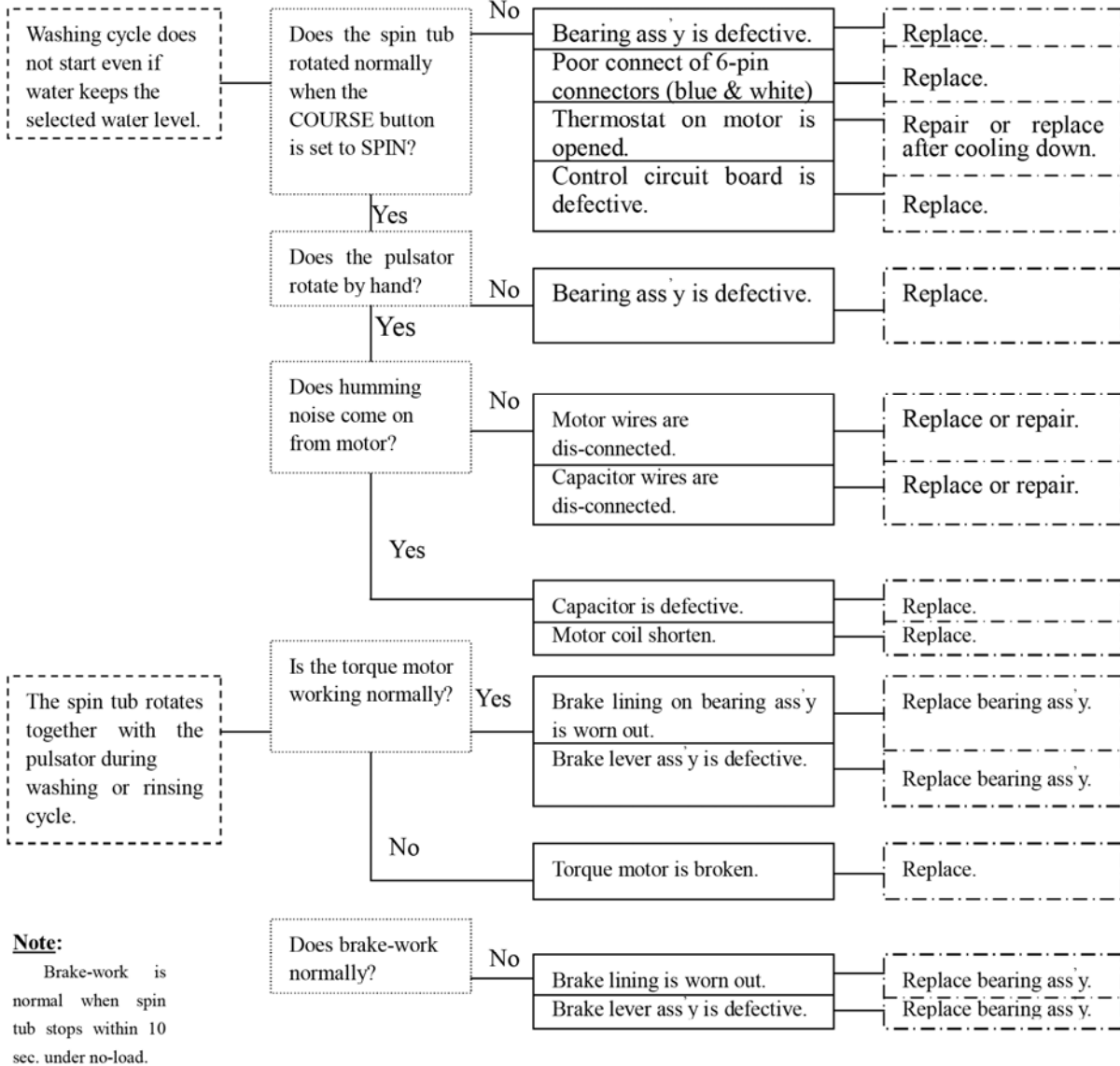

d. Drain

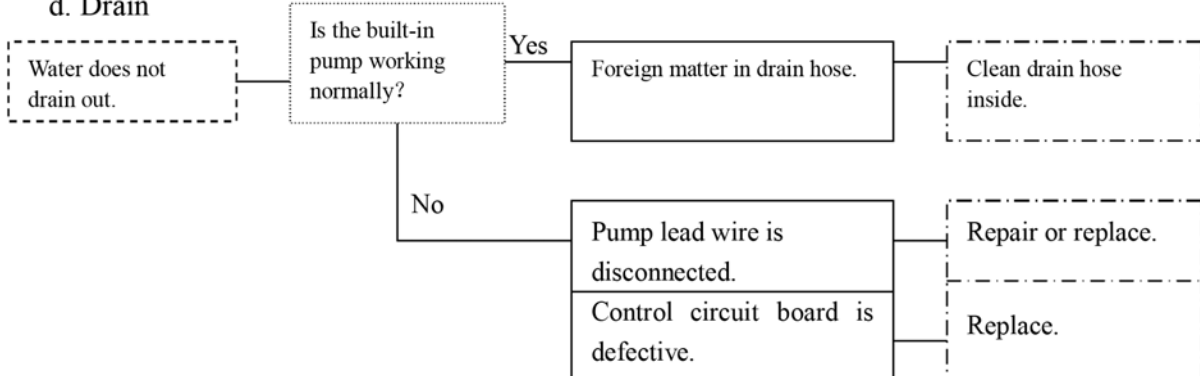

TROUBLE	INSPECTION	CAUSES	REMEDY
---------	------------	--------	--------

Drain takes time too long.

**Note:** In draining, the water level sensor can not reset in 8 minutes.  
The number window LED display abnormal code: **E2** and begin blinking on and off at the same time and the electric buzzer sounds to indicate a problem.

- Drain hose ass'y is deformed.
- Hose is connected in the wrong way.
- Hose is too long or position of hose is too high.

- Repair or replace.
- Repair.
- Repair.

- If the Drain Hose is too long or high, water may overflow during the rinsing cycle or make rinsing or draining impossible.
- The built-in pump is capable of discharging water to a maximum height of 1.0 meters and minimum height of 0.7 meters.
- The pump makes a noise at the starting.  
If you want to reduce the noise, please raise the opening end of the Drain Hose above the floor 1 meter or more.  
The pump makes an idling noise during washing.  
This is normal.

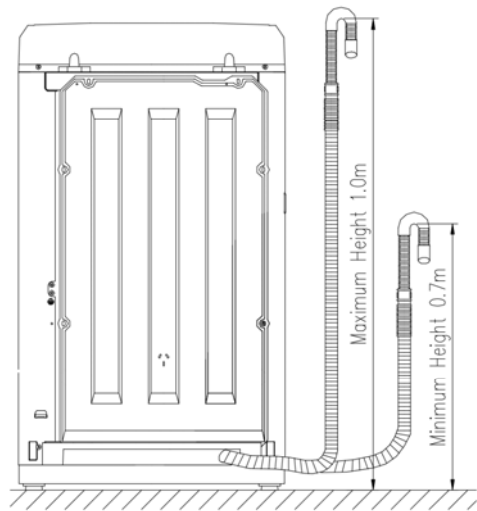

e. Spin Drying

Spin drying cycle does not work.

Does safety device work?

Yes  
Machine inclines.

Replace with level.

- Note:**
1. The safety switch works 3 times continuously or works 1 time in the single program of spin-dry. The number window LED display abnormal code: **E3** and begin blinking on and off at the same time and the electric buzzer sounds to indicate a problem.
  2. Do not disconnect the wire from the capacitor, because this wire acts as de-pressing noise from outside to the micro-computer.

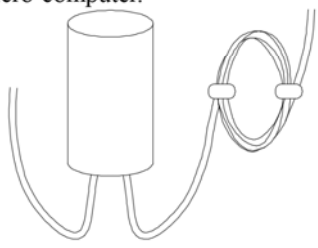

- The V-belt is slipping.
- The V-belt is snapped.
- Small pulley mounting screw is loosed.
- Motor is disconnected or burnt.
- Capacitor is broken or disconnected.
- Bearing ass'y is defective.
- Torque motor is defective.
- Brake lever is defective.
- Thermostat on motor is opened.
- Poor contact of 6-pin connectors (blue & white).
- Control circuit board is defective.

- Adjust the motor position.
- Replace.
- Tighten up.
- Replace.
- Replace.
- Replace.
- Replace.
- Repair or replace.
- Repair or replace after cooling down.
- Repair or replace.
- Replace.





Operation of safety device

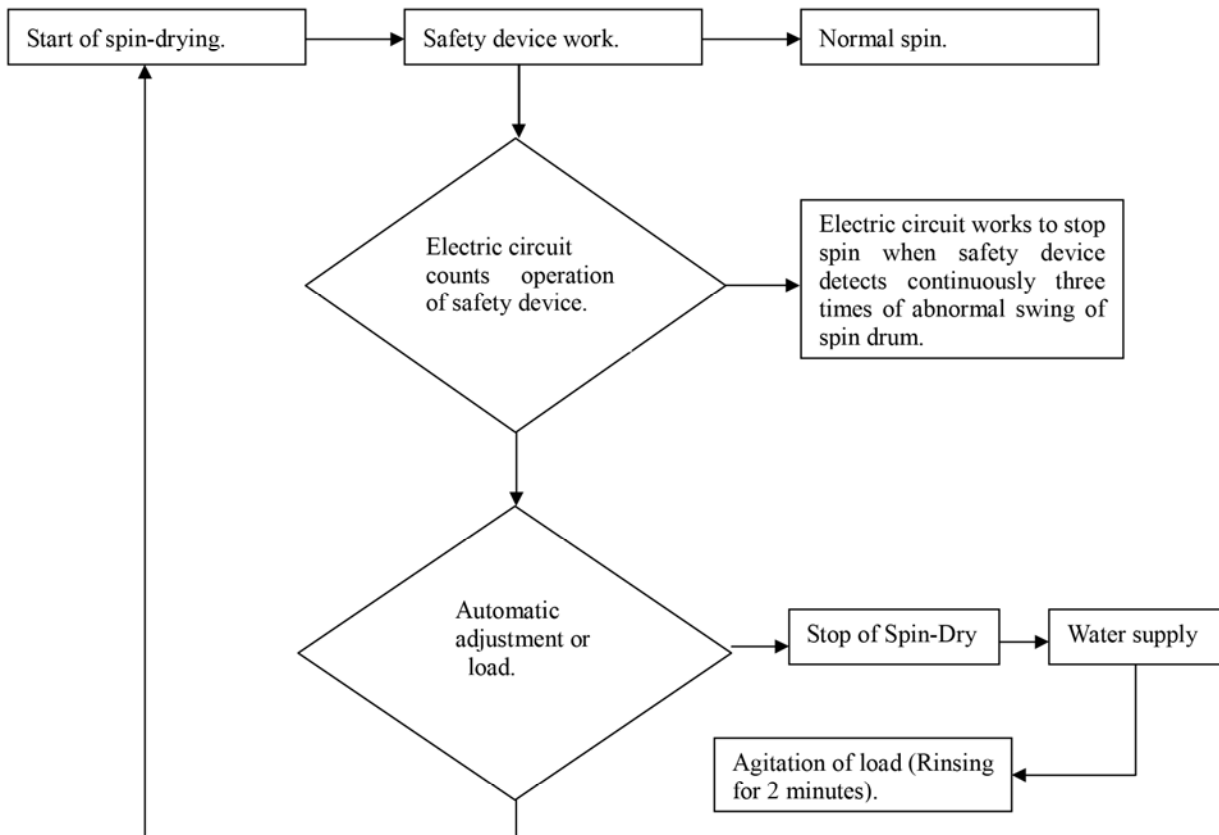

When the safety device works by abnormal swing of spin drum, machine works automatically to stop Spin-Dry cycle and operates water supply valve to pour water into the Wash/Spin Tub and then starts washing cycle for replacing washing clothes evenly.

After above operation has down twice, if safety device works again, machine will stop, and the number window LED display abnormal code: **E3** and begin blinking on and off at the same time and the electric buzzer sounds to indicate a problem.

- Open the Wash Lid and rearrange the clothes evenly around the Wash/Spin Tub.
- Close the Wash Lid and press the START/PAUSE button again.

f. Buzzing and rattling

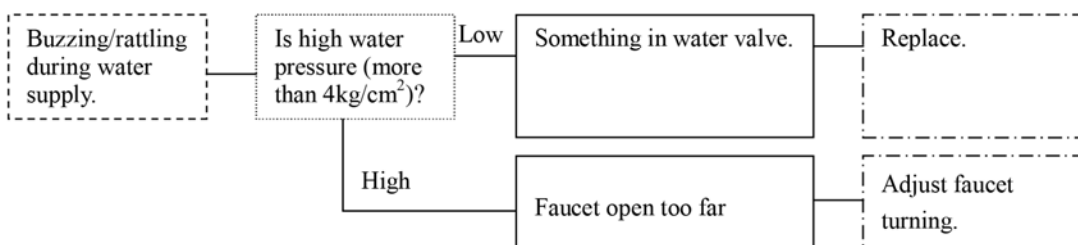

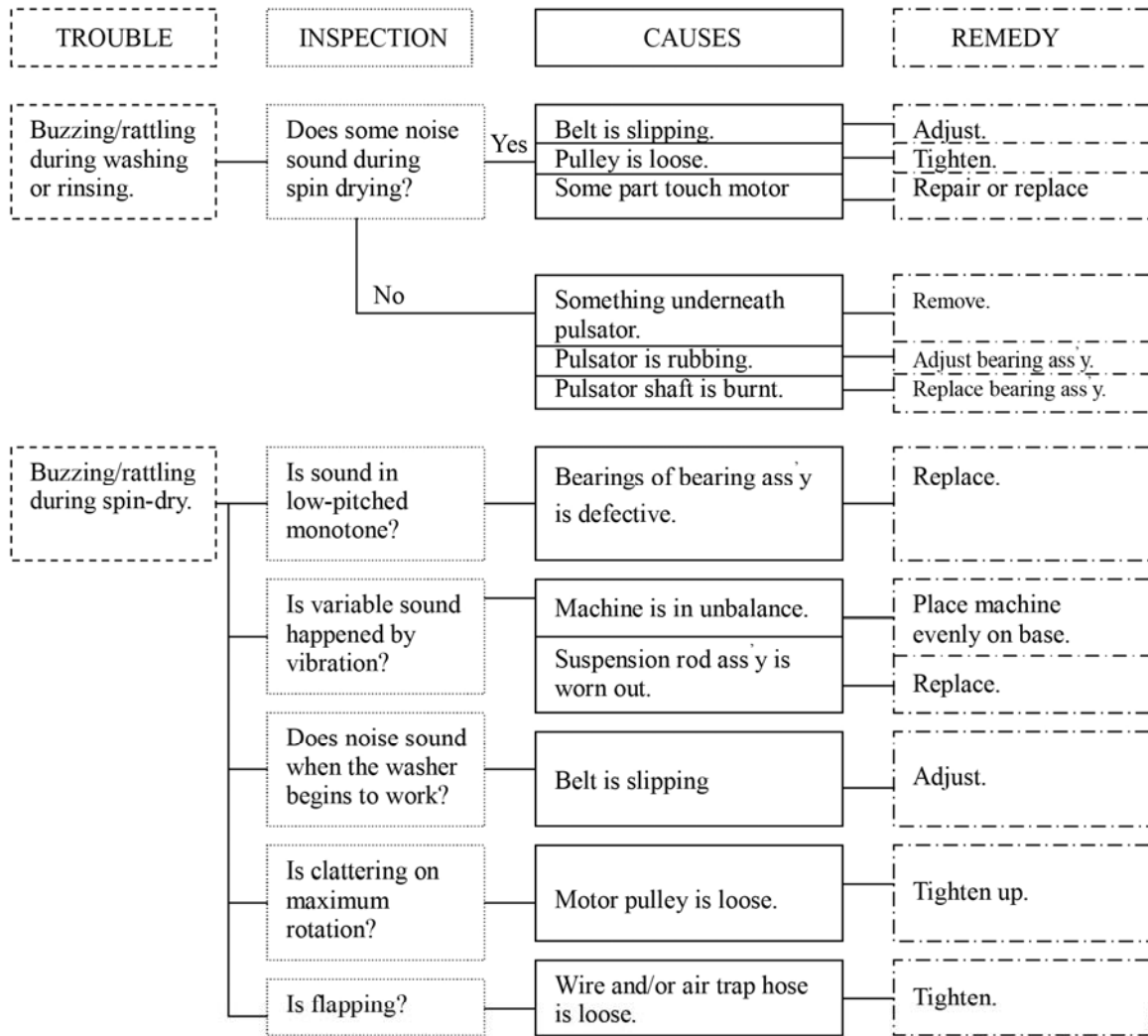

#### PART LIST

Key No.	Part No.	Description	Q ty
1	301B801700179	Control Circuit Board Complete	1
2	ST1TN40160SE	SCR 4×16	7
3	301B121000170	Panel & stickers	1
4	3012160427048	Lid Handle	1
5	ST1TN40120UK	SCR 4×12	3
6	3012160516140	Screw Lid	3
7	3014201S02140	magnet	1
8	3012160387042	Washer Lid	1
9	3012160613140	Hinge Shaft	1
10	3012160717140	Lid Spring	1
11	3012131726140	Notice Label	1
12	3012175120043	Back Plate B	1
13	3012175119040	Back Plate A	1
13-1	3012174904140	Water Valve Cover	1
14	ST1TN40120SE	SCR 4×12	2

Key No.	Part No.	Description	Qty
15	3010571005140	Safety Device Switch1	1
16	ST1TN40140SE	SCR 4×14	2
17	ST1TN40140SE	SCR 4×14	3
18	3014294S30140	Valve Assembly(Water Valve)	1
19	3012212701140	Water Valve tie_in	1
20	3012317213040	Pour Inlet	1
21	3012317317040	Baffle Plate Of Pour Inlet	1
22	ST1TN40100UK	SCR 4×10	4
23	3014291S03140	Response Switch(Water Level Sensor)	1
24	3012334002140	Hose Band	2
25	3012324205140	Air Trip Hose	1
26	3012143414140	Cushion	1
27	ST1TN40120SE	SCR 4×12	4
28	3012160128040	Top Plate	1
29	3012256120041	Detergent Tray	1
30	3012161201140	Gradienter Cover	1
31	3010161101140	Gradienter	1
32	3012160510142	Screw Cap	2
33	3014292S04140	Reed Switch	1
34	3012912223140	Special Screw	1
35	3012851598140	Wire bunch	1
36	3010111034047	Frame Complete	1
37	3012914201140	Stopping Pin (included in item 88 &89)	4
38	3012234201140	Spring Damper Base (included in item 88 &89)	4
39	3012912223140	Special screws	7
40	3012122201141	Back Cover	1
41	3012122101141	Frame Handle	2
43	3012334001140	Hose Band	1
44	3012324828140	Drain Hose Assembly (Inside)	1
45	3012334006140	Hose Band	1
46	3014535S02140	Pump	1
47	3012912201140	Screw Assembly	2
48	3012851514140	Pump Wire	1
49	3012324919140	Drain Hose Stay	1
50	3012324916140	Drain Hose Stay	1
51	3010325101140	Drain Hose (Outside)	1
52	3012334006140	Hose Band	1
53	3012152313140	Leg	1
54	ST1TN40120SE	SCR 4×12	7
55	3010143002140	Adjuster Assembly	1
56	3012234302040	Sound-Proof Board	1
57	ST1TN40140SE	SCR 4×14	1
58	3012143401140	Cushion	3
59	ST2TN60200SE	SCR 6×20	3

Key No.	Part No.	Description	Qty
60	3012152503140	Lead Stay	2
61	3010812010140	Cord Assembly(E2)	1
62	3012152501140	Cord Stay	1
63	ST1TN40100SE	SCR 4×10	1
64	3014295S05140	Capacitor Assembly(11.5μF/500V Ac)	1
65	3010856501140	Earthing Wire Assembly	1
66	SFSPG40100SA	SCR 4×10A	3
67	SVCNN40KA---	Washer SPR 4	2
68	3012813007140	Part Bag	1
69	3012871103140	Compressed Connector	4
70	3012871102140	Compressed Connector	1
71	3012411301140	Pulsator Screw	1
72	3012411401140	Pulsator Screw Washer	1
73	3012411004143	Pulsator	1
74	3012411501140	Pulsator Washer	1
75	3012221201143	Outer Tub Cover	1
76	ST1TN40140SE	SCR 4×14	4
77	3012912202140	Special Screw	4
78	3010240020040	Spin Tub Complete	1
79	3010240104043	Balance Weight Assembly	1
80	3012241205140	Cap	1
81	3010241109043	Spin Tub Assembly	1
82	ST1TN50210UK	SCR 5×21K	6
83	3012240205140	Spin Tub Boss	1
84	3010912305140	Boss Screw Assembly	8
85	3010212305143	Lint filter Assembly	1
86	3012324521141	Circulate Hose	1
87	ST1TN40120UK	SCR 4×12K	4
88	3010234419140	Suspension Rod Complete	3
89	3010234420140	Suspension Rod Complete (Motor Side)	1
90	3012221101040	Outer Tub Drum	1
91	3012212202140	Drain Pipe	1
92	3012324111140	Overflow Hose	1
93	3010420003140	Bearing Assembly	1
94	3012912208140	Special Screw 6×30	4
95	SFSPG40100SA	SCR 4×10A	2
96	3010856505140	Earthing Wire Assembly (L=55mm)	1
97	3012915202140	Insulator Plate	2
98	3010912304140	Screw Assembly	2
99	201D0055	Motor Complete	1
100	3010412501140	Motor Pulley	1
101	3012991701140	V-Belt	1
102	3010152302140	Motor Angle Holder Assembly	1
103	3012912209140	Special Screw	4

Key No.	Part No.	Description	Qty
104	3014264S10140	Torque Motor	1
105	3012912207140	Special Screw	2
106	3010325405140	Feed Hose Assembly	1
107	3012342703140	Connector	1
108	ST1TN40100SE-	SCR 4×10	1
109	3010350302040	Ultrasonic Pump Complete	1
109-1	3010351102140	Ultrasonic Pump Assembly	1
109-2	3010323902140	Air Trip Hose Complete	1
109-3	3012143417140	Cushion	1
110	3012152509140	Ultrasonic Pump Assembly Stay	1
111	3012912213140	Special Screw M5×20	1
112	3012143408140	Cushion	1
113	3012152510140	Lead Stay SWM-G D0.8X115L	3

# ExplodedView (1)

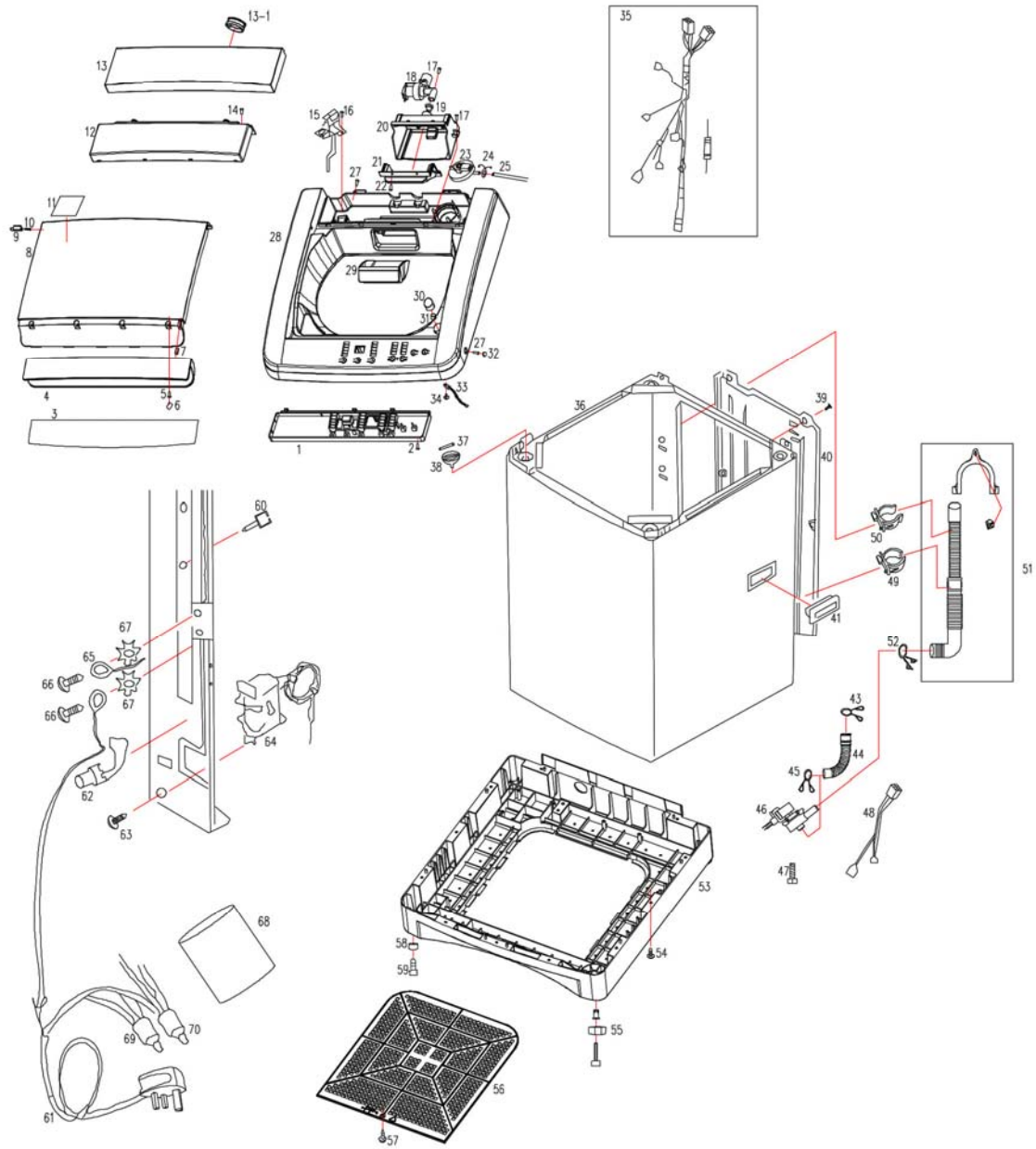

# ExplodedView (2)

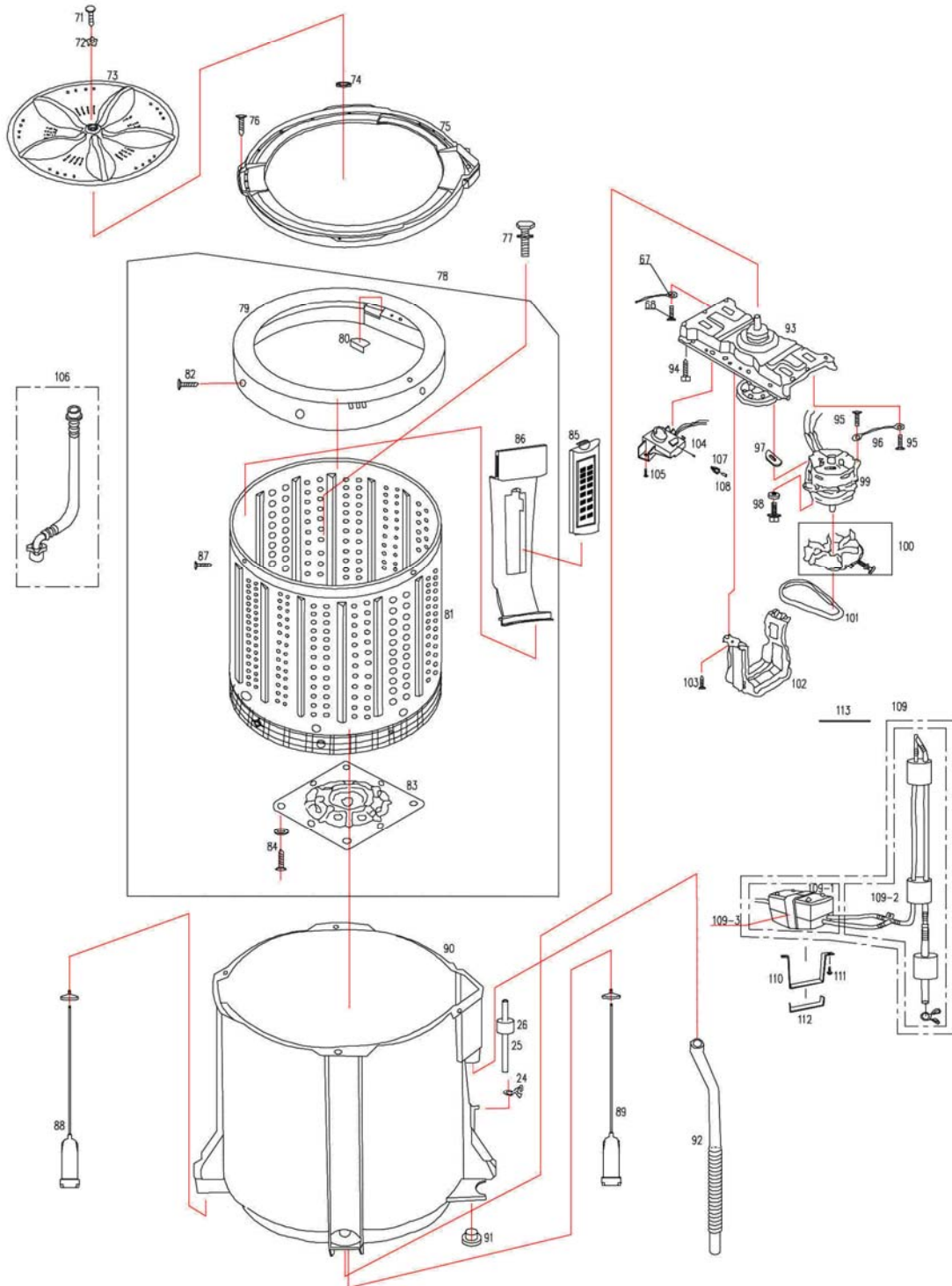

## TEARDOWN SECTION

This section will describe how to remove components from a top load washer. Unless stated, the procedure will be the same on all top load washers, Unless stated, reverse the procedure to reinstall the component.

**Warning: Always remove electrical power from the washer when working in an area where electrical power is present.**

### Removing the washer lid



Open the washer lid, move the hinge shaft on the washer lid with slotted screwdriver, then remove the washer lid.

### Removing the back plate



First use cross-style screwdriver to demount the two screws fixed on the back plate. Then use slotted screwdriver to warp the back plate assembly, and sway the back plate assembly gently, then the back plate assembly can be removed.



### Removing the safety device switch



Use cross-style screwdriver to demount the two screws fixed on the safety device switch, pull out the jack, draw the safety device switch out from the slot.

### Removing the pour inlet assembly



First draw out the detergent tray, then use cross-style screwdriver to demount the two screws fixed on the pour inlet assembly, pull out the jack, draw the pour inlet assembly from the step surface.

### Removing the water level sensor



Warp the fastener on the top plate, pull out the jack and air trip hose, then draw the water level sensor out from the top plate.

## Removing the control circuit board complete



First open the zygomorphic screw cap on the top plate, then demount the two screws by cross-style screwdriver. Second demount the two screws behind the top plate, slant the top plate, demount the seven screws on the control circuit board complete, pull out the jack, then the control circuit board complete can be removed.

## Removing the reed switch



Use cross-style screwdriver to demount the special screw fixed on the reed switch, pull out the jack, then the reed switch can be removed.

## Removing the top plate

Complete all the previous steps, draw out the wire bunch, the top plate can be removed without difficulty.

## Removing the pump



Use the sleeve spanner to demount the two screw assembly under the leg, pull out the pump wire assembly, then the pump can be removed.

## Removing the motor complete and the motor pulley



First of all, the outer tub drum assembly must be removed. Demount the two screw assembly on the motor complete, then the motor complete is demounted. At the same time, the motor pulley is removed for it is

connected with the axis of the motor.

<b>Revisione</b>	<b>Data</b>	<b>Descrizione</b>	<b>Autore</b>	<b>Approvato da:</b>
00	01/2014	Creazione documento	DMM	XX – 0X/201X