



©ELECTROLUX HOME
PRODUCTS
Customer Care - EMEA
Training and Operations
Support
Technical Support

Publication
Number

599 75 82-68

SIDE by SIDE
II generation

Edition: 12/2011 - Rev. 00

EN

1. Information

Buyer No.		Basic	I & W I & W + H/ Bar	I & W + M/C Zone I & W + H/Bar + M/C Zone
Factory No.		FRX-62PB..	FRX-60PD(F)..	FRX-60PE(G)..
Gross Vol. (ISO 15502)	Total	622	608	608
	Freezer	242	228	228
	Refrigerator	380	380	380
Storage Vol. (ISO 15502)	Total	577	549	549
	Freezer	204	179	179
	Refrigerator	373	370	370
Diemension	Width (mm)	906	906	906
	Depth (mm)	735	735	735
	Height (mm)	1770	1770	1770
Weight (kg)		98 kg	107 / 109 kg	109 / 111 kg

Cooling Cycle	Refrigerant Type	R-134a or R-600a		
	Refrigerant Charge	190g (R-134a) or 75g (R-600a)		
	Evaporator Type	Fin Type		
	Condenser Type	Compulsory Convection Type		
	Dryer	Molecular Sieve xH-9		
	Capillary Tube	ID0.7 x T0.55 x L2,340		
Heater	Defrost Heater	280W		
	Dispenser Heater	x	3W	3W
	Water Pipe Heater	x	5W	5W
	H/Bar Heater*	x	5W*	5W*
Sensor	Defrost Sensor	PBN-43		
	Freezer Sensor	PT-38		
	Refrigerator Sensor	PBN-43B		
Electronic Part	Fuse Temp. (Defrost)	AC 250V, 10A, 77C		
	Freezer Fan Motor	DC 12V, 1400rpm		
	Refrigerator Fan Motor	x		
	Condenser Fan Motor	DC 13V, 1100rpm		
	Freezer Lamp	LED (DC12V / 1.44W)		
	Refrigerator Lamp	LED(DC12V / 2.16W)		

- H/Bar Heater* : Not all models, H/Bar models only.

2. Outside Diemension

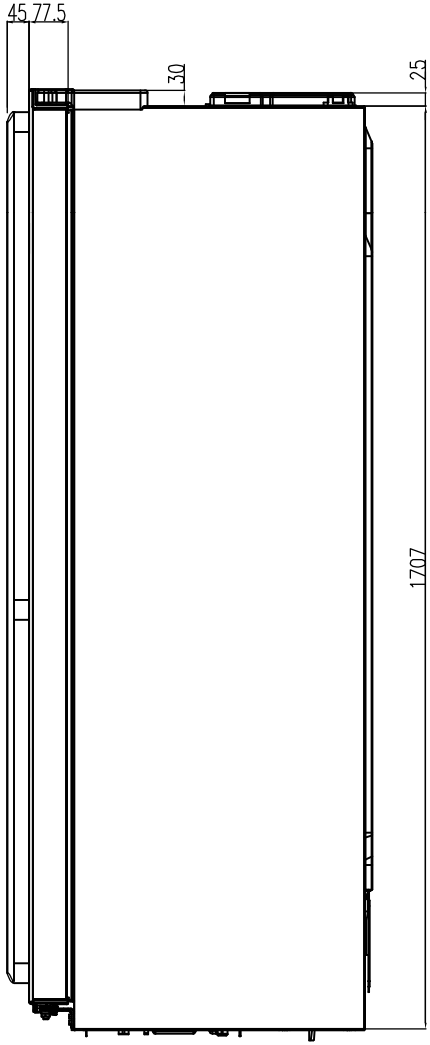
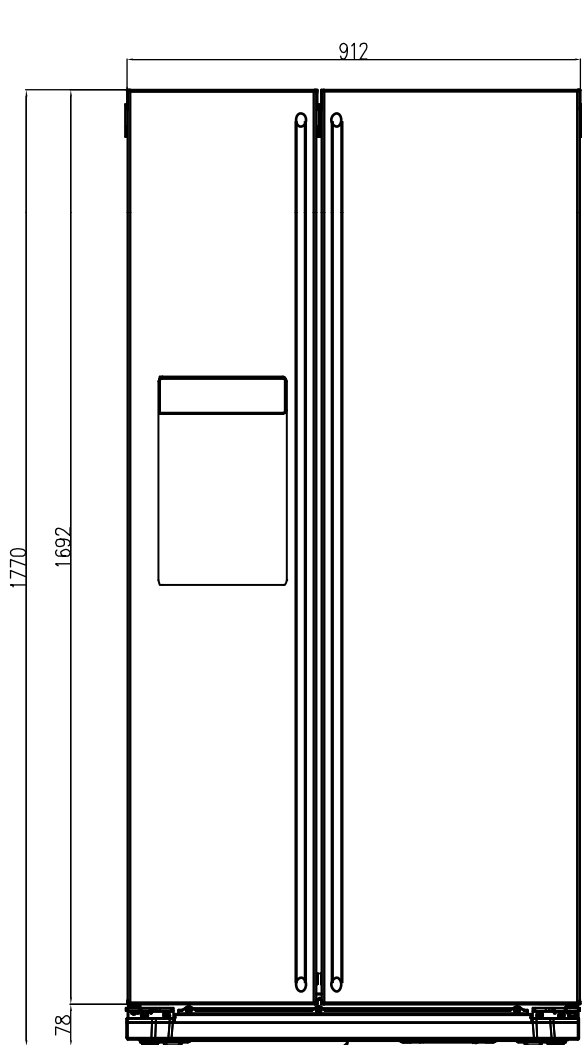
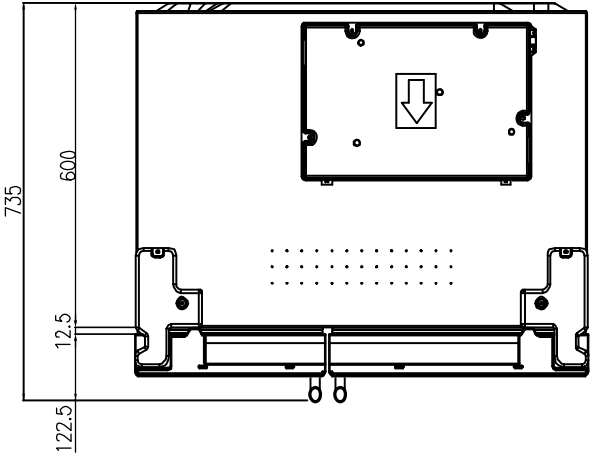

[Features are model dependent]

3. Interior Parts

1) Basic Model

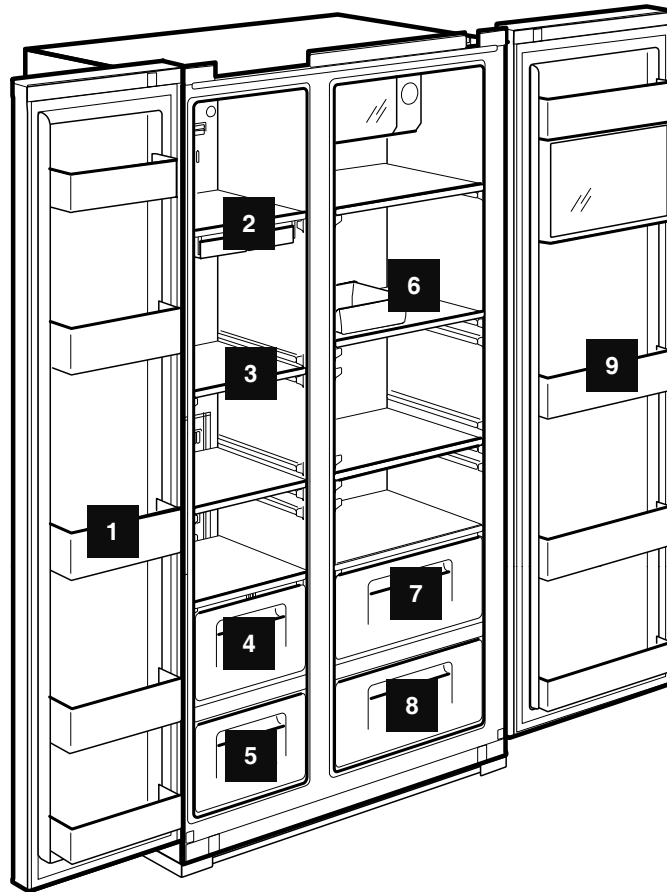

1) Freezer Pocket

2) Freezer Ice Tray

3) Freezer Shelf

4) Freezer Case 1

5) Freezer Case 2

6) Refrigerator Shelf

7) Vegetable Case 1

8) Vegetable Case 2

9) Refrigerator Pocket

2) Dispenser Model



- The real features are model dependent.

- | | |
|---------------------|----------------------------------|
| 1) Freezer Pocket | 6) Refrigerator Shelf |
| 2) Ice Storage Case | 7) Vegetable Case 1 |
| 3) Freezer Shelf | 8) Vegetable Case 2 |
| 4) Freezer Case 1 | 9) Magic Cool Zone (Option) |
| 5) Freezer Case 2 | 10) Refrigerator Pocket (Option) |
| | 11) H/bar Pocket |

[Basic Models]

1. Display (Basic Type)

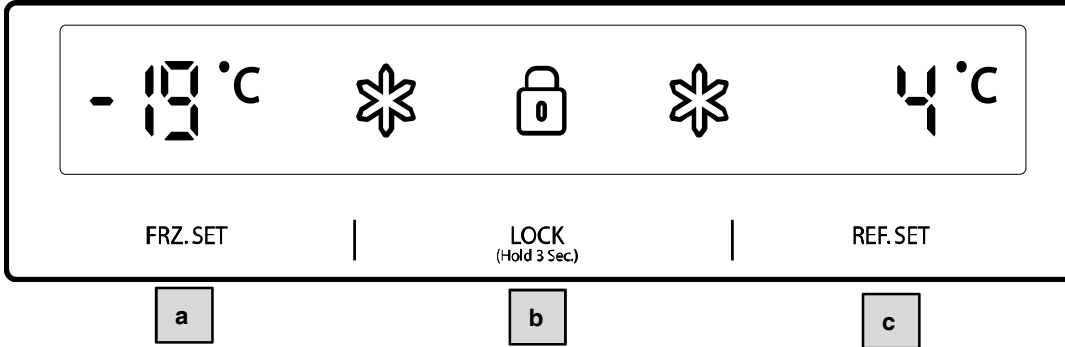

- a Temperature adjustment button for freezer compartment.
- b Lock & Unlock button.
- c Temperature adjustment button for refrigerator compartment.

2. Display Control

FCP	Control
Temp. Display (Set Temp.)	Initial Mode : Freezer / Refrigerator set medium (-19C / 4C)
Quick Freezer & Refresh Compartment	Button
KEY LOCK	Button

3. FRZ.SET button

- 1) Temperature control of freezer compartment.
 - 2) Initial power plug in : Medium (-19C)
- Every time you press the FRZ.SET button, the setting temperature changes below order.



4. REF.SET button

- 1) Temperature control of refrigerator compartment
 - 2) Initial power plug in : Medium (4C)
- Every time you press the REF.SET button, the setting temperature changes below order.



5. LOCK Mode (Childproof lock)

- 1) When lock the other buttons, press LOCK button. (In this mode other buttons are unable)
- 2) To unlock, press again for 3 seconds .

[Dispenser Models]

1. Display (Dispenser Type)

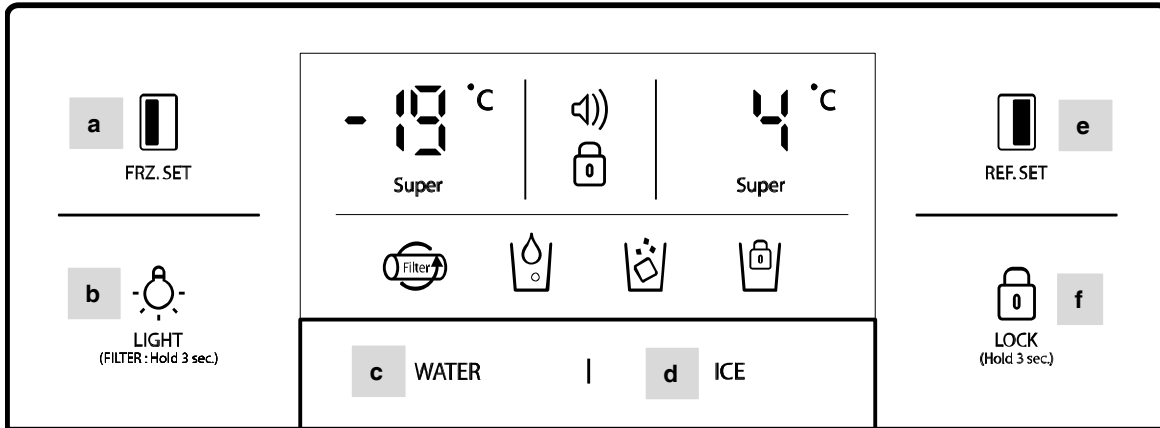

- a Temperature adjustment button for freezer compartment.
- b Dispenser light & Water Filter Reset button.
- c Water selection button.
- d Ice selection & Ice Maker Lock button.
- e Temperature adjustment button for refrigerator compartment.
- f Lock & Unlock button.

2. Display Control

FCP	Control
Temp. Display (Set Temp.)	Initial Mode : Freezer / Refrigerator set medium (-19C / 4C)
Quick Freezer & Refresh Compartment	Button
Lock ice maker / Cubed ice	Button
KEY LOCK	Button
FILTER CHANGE	AFTER 6 Month, LED ON

3. FRZ.SET button

- 1) Temperature control of freezer compartment.
 - 2) Initial power plug in : Medium (-19C)
- Every time you press the FRZ.SET button, the setting temperature changes below order.



4. REF.SET button

- 1) Temperature control of refrigerator compartment
- 2) Initial power plug in : Medium (4C)

- Every time you press the REF.SET button, the setting temperature changes below order.



5. RESET WATER FILTER

After 6 month of first power input, () icon is flickering.

To reset the icon flickering, push the LIGHT button for 3 seconds after exchanging the Water Filter.

Then () icon is disappear.

6. WATER/ICE select

- 1) When push the WATER button, water dispensing available.
- 2) When push the ICE button, cubed ice dispensing availabel.
- 3) The initial mode is WATER.

7. ICE MAKER LOCK

- 1) Push the 'ICE' button for 3 seconds. To unlock push the ICE button for 3 seconds.

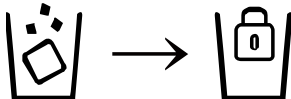

- 2) When cleaning the ice storage case or when not use for a long period of time.

8. LOCK Mode (Childproof lock)

- 1) When lock the other buttons, press LOCK button.
(In this mode other buttons are unable)
- 2) To unlock, press again for 3 seconds .

< REFERENCE >

: Please wait for 2 ~ 3 seconds in order to take final ice or drops of water when taking out cup from the pressing switches after taking ice or water.

: The actual inner temperature varies depending on the frood status, as the indicated setting temperature is a target temperature, not actual temperautre within refrigerator.

1. Freezer Compartment Control

- 1) Adjust by the pushing the FRZ.SET button.
- 2) Compressor & Freezer Fan controlled by each mode ON/OFF point.
- 3) Freezer Compartment ON/OFF Difference : 4C
 - MEDIUM OFF point : -19.8C
- 4) Control Temperature Point in Each Mode

Division		Initially On	1st Press	2nd Press	3rd Press	4th Press	5th Press	6th Press
Display		-19	-20	-21	-22	-16	-17	-18
Temperature Control		Medium	Medium Max		Max	Min	Medium Min	
Normal	Sensor On	-15.8	-16.8	-18.8	-20.5	-10.6	-13.9	-14.8
	Sensor Off	-19.8	-20.8	-22.8	-24.5	-14.6	-17.9	-18.8

6) QUICK FREEZER Mode

- In this mode, Compressor & Freezer Fan motor is on unconditionally for 24hours. (free of freezer sensor)

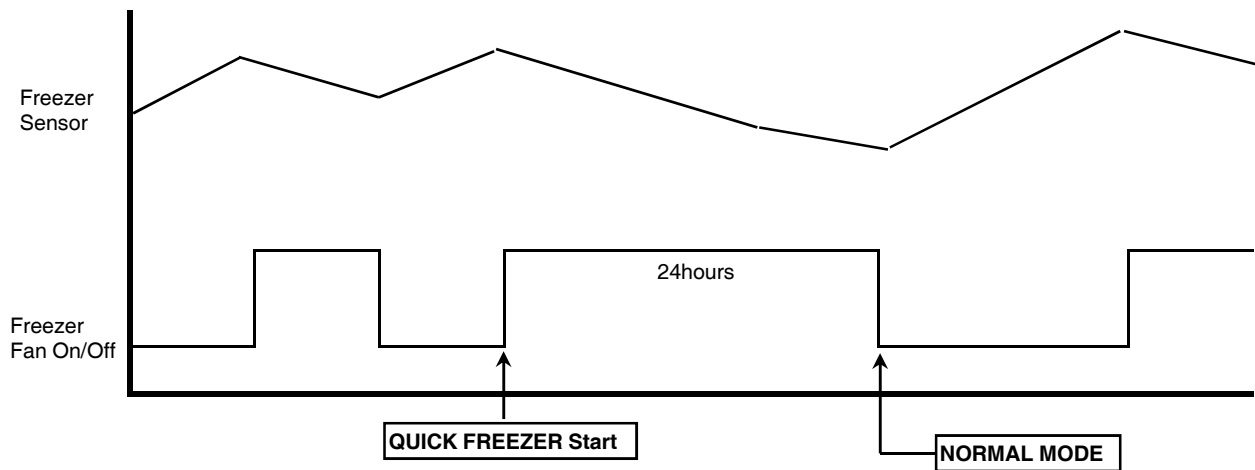

2. Refrigerator Compartment Control

1) Adjust by the pushing the REF.SET button.

2) Refrigerator Damper controlled by each mode ON/OFF point.

3) Refrigerator Compartment ON/OFF Difference : 0.5C

- MEDIUM OFF point : 6.0C

- When Room Temperature (RT) is below 15C, Refrigerator sensor OFF point 2C down.(so, MEDIUM OFF :4.0C)

4) Weak Cooling Prevention Function

※ This function is only for medium~max

- This function is free of Freezer sensor.

- When refrigerator compartment reaches the Fan OFF point, the sensor off.

Compressor controlled by Freezer sensor.

- Weak cooling temperautre is + 7C in each dial sensor OFF temperature.

- Weak cooling terminate temperautre is same as each dial sensor OFF temperature.

5) Control Temperature Point in Each Mode

Division		Initially On	1st Press	2nd Press	3rd Press	4th Press	5th Press	6th Press
Display		4	3	2	8	7	6	5
Temperature		Medium	Medium Max	Max	Min	Medium Min		
Normal	Sensor On	6.5	5.5	4.5	10.5	9.5	8.5	7.5
	Sensor Off	6.0	5.0	4.0	10.0	9.0	8.0	7.0
RT <= 15C	Sensor On	4.5	3.5	2.5	12.5	11.5	10.5	9.5
	Sensor Off	4.0	3.0	2.0	12.0	11.0	10.0	9.0
Weak refrigeration	Sensor On	13.0	12.0	11.0	17.0	16.0	15.0	14.0
	Sensor Off	6.0	5.0	4.0	10.0	9.0	8.0	7.0

6) QUICK REFRIGERATOR Mode : This mode runs for 40 minutes.

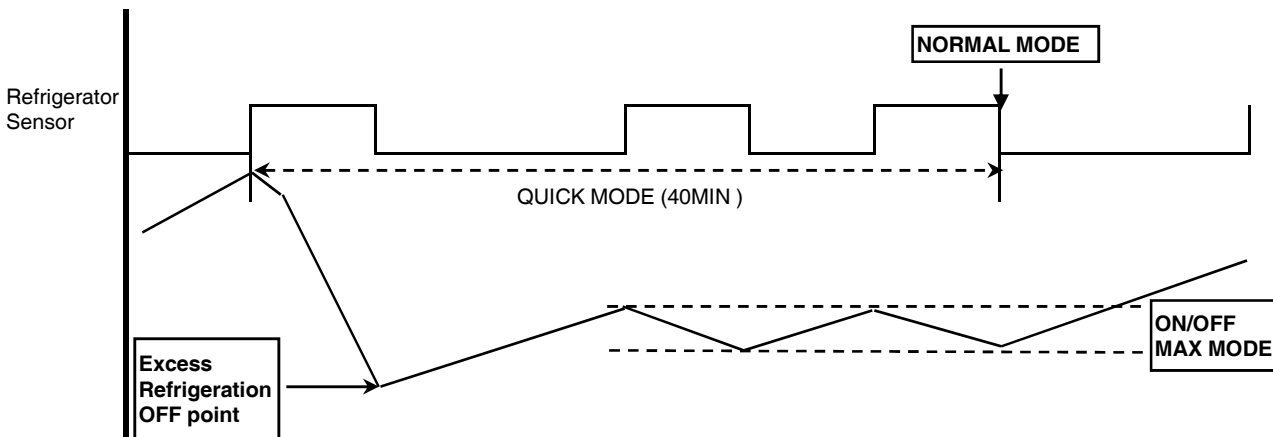

- Until the sensor reaches the Excess Refrigeration OFF point (-7C), Refrigerator Damper, freezer fan and compressor is ON.

- Until the QUICK Mode ends, the appliance runs with MAX dial mode.

- After QUICK Mode (about 40 mins) the normal mode start.

3. Fan voltage per control mode

Exerted fan motor voltage

Mode	F-Fan	C-Fan
Normal	10 V	13 V
Freezer High Speed	13 V	13 V
Freezer Against LOAD	13 V	13 V

- 1) Normal control : Slow operation mode with relatively low noise level.
- 2) Load response : Operation mode which need to be operated by temperature rise at inner side of refrigerator according to operating condition.

4. Load response mode

- 1) Purpose : To recover temperature rise inside of refrigerator as quickly as possible by heavy load or frequent door opening.
- 2) Operating condition
 - When door opening time is more than 1 minutes per 1 time -> F/R go to load response mode.
 - When sensing more than R/S On Point + 5deg -> R load response.
 - When sensing more than F/S On Point + 5deg -> F load response.
- 3) Conditions for not entering into load response mode.
 - When there is no door opening signal during and after defrost cycle, load response mode is not entered into operation.
 - But, when there is door opening signal during defrost cycle with load response entering condition (More than on Point + 5deg), it enter into load response mode.
- 4) Finish condition
 - F, R load response mode finishes 20 minutes after entering into load response mode.
(But, when operating condition enter again 20 minutes after load response mode, load response mode starts again)
 - When R sensor reaches to off point, R load response mode finishes.
 - When F sensor reaches to off point, F load response mode finishes.

1. When Defrost Mode start?

- ; When total Compressor running time becomes at 10,12,14..40hours.
- The compressor running rate is over 80% every 16 hours.
- Door opening time is over 2 minutes (Each Freezer / Refrigerator door)
- Total compressor running time (on time + off time) is 60hours.
- Any error happens. (R1, F1, D1, F3, RT-Sensor, C1, Door switch etc.)
- (But, F3 error happens then defrost mode start without Pre-cool)

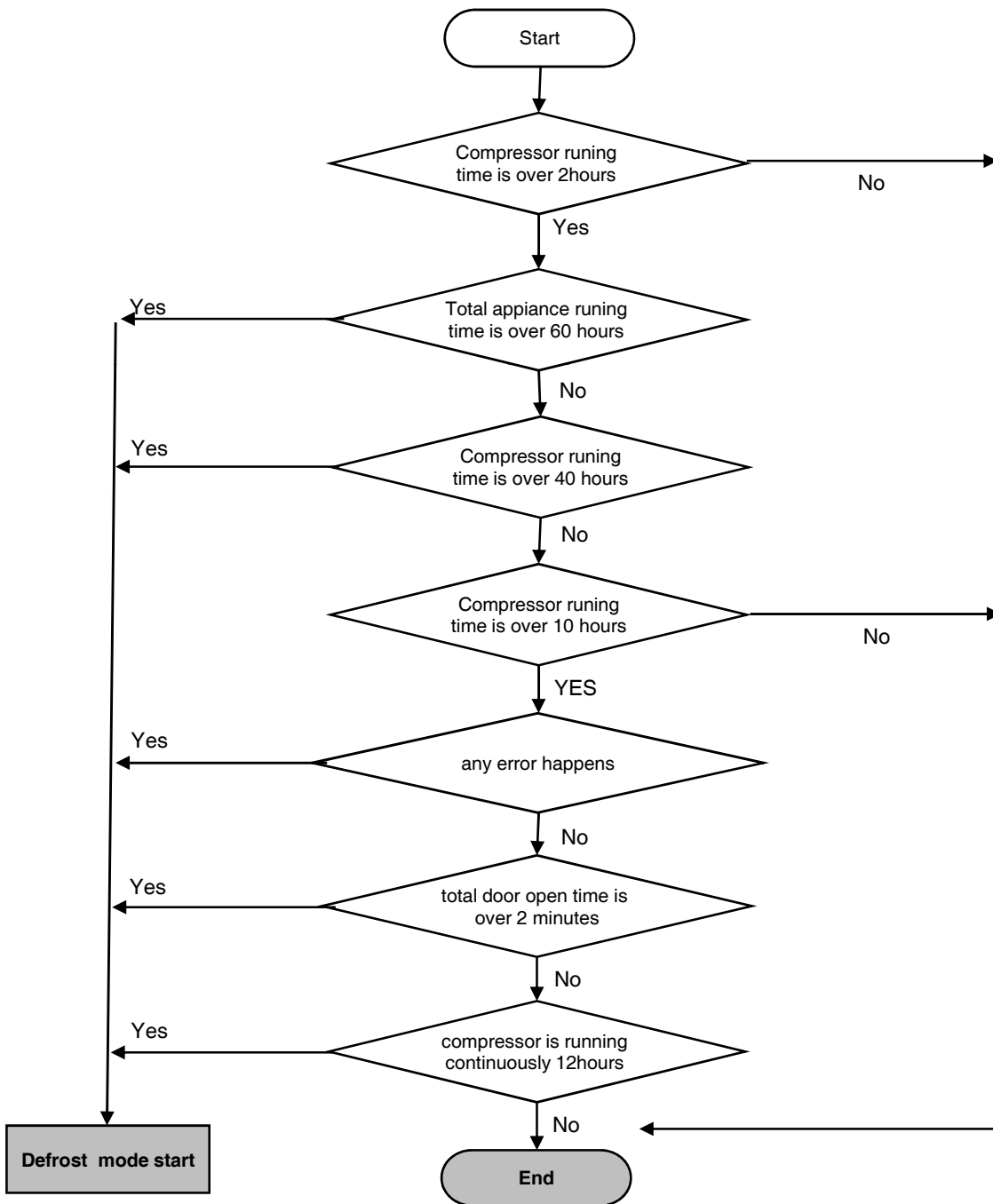

2. Normal Defrost Mode

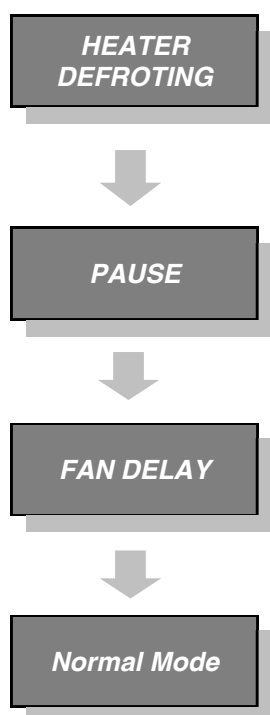

1) HEATER DEFROSTING

- Defrost heater is switch on until Defrost Sensor temperature reaches 13C.
- Heater operation time
 - ; 30 seconds - Heater is ON free of Defrost Sensor.
 - ; 30 minutes - When Defrost Sensor is malfunction. (D1 error)
 - ; 60 minutes - Heater maximum operation time. (F3 error)

2) PAUSE

- After Defrost Heater switch OFF, Compressor dosen't run within 10 minutes.

3) FAN DELAY

- Freezer & Refrigerator fan switch on after 5miunuts' cmpressor running.

<i>Division</i>	<i>HEATER DEFROST</i>	<i>PAUSE</i>	<i>FAN DELAY</i>
<i>Compressor</i>	<i>OFF</i>	<i>OFF</i>	<i>ON</i>
<i>Freezer Fan</i>	<i>OFF</i>	<i>OFF</i>	<i>OFF</i>
<i>Refrigerator Fan</i>	<i>OFF</i>	<i>OFF</i>	<i>OFF</i>
<i>Defrsot Heater</i>	<i>ON</i>	<i>OFF</i>	<i>OFF</i>
<i>Time</i>	<i>30min (D1 error) 60min (F3 error)</i>	<i>10min</i>	<i>5min</i>

1. How to enter this check mode

- 1) Push the LOCK button.
- 2) Push the LOCK button 5 times while pressing the FRZ.SET button.

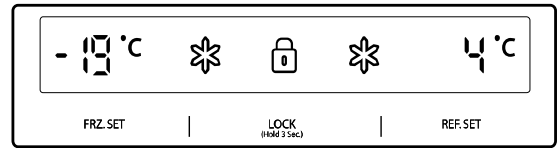

2. The Front LED displays the current error code (if happens).

; Every time you press the Freezer Set button, the following value display.

- 1) The appliance running time. (From the plug in.)
- 2) Freezer sensor temperature.
- 3) Defrost sensor temperature.
- 4) Refrigerator sensor temperature.
- 5) Room temperature.

3. How to exit this mode

- 1) Push the LOCK button.
- 2) After 4 minutes automatically exit.

4. Error Code

No	Display (Error Code)	Remark
1	F1	Freezer sensor disconnection or short
2	r1	Refrigerator sensor disconnection or short
3	rt	Room temperature sensor disconnection or short
4	d1	Defrost sensor disconnection or short
5	dr	Refrigerator Door switch is defective.
6	dF	Freezer Door switch is defective.
7	C1	Abnormal or defective cycle
8	F3	Return after defrosting : abnormal or defective
9	Co	Pull-Down mode display (No error)
10	d2	Forced Defrost mode display (No error)

; All Error Code reset, when the relative parts turn into normal.

1. How to enter this check mode

- 1) Push the LOCK button.
- 2) Push the WATER button 5 times while pressing the FRZ.SET button.

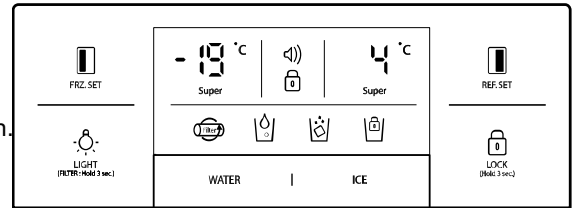

2. The Front LED displays the current error code (if happens).

; Every time you press the Freezer Set button, the following value display.

- 1) The appliance running time. (From the plug in.)
- 2) Freezer sensor temperature.
- 3) Defrost sensor temperature.
- 4) Refrigerator sensor temperature.
- 5) Room temperature.
- 6) P Factor display.
- 7) Filter remaining time until exchange. (Initial filter running time is about 4,320 Hour = 6 months)

3. How to exit this mode

- 1) Push the LOCK button.
- 2) After 4 minutes automatically exit.

4. Error Code

No	Display (Error Code)	Remark
1	F1	Freezer sensor disconnection or short
2	r1	Refrigerator sensor disconnection or short
3	rt	Room temperature sensor disconnection or short
4	d1	Defrost sensor disconnection or short
5	dr	Refrigerator Door switch is defective.
6	dF	Freezer Door switch is defective.
7	dH	Home Bar Door switch is defective.
8	EI	Ice sensor disconnection or short
9	EF	Flow sensor is defective.
10	Et	Horizontal switch error
11	Eg	Water supply error
12	EA	Drop the ice while Et
13	Eu	Full ice switch error
14	C1	Abnormal or defective cycle
15	F3	Return after defrosting : abnormal or defective
16	Co	Pull-Down mode display (No error)
17	d2	Forced Defrost mode display (No error)

; All Error Code reset, when the relative parts turn into normal.

5. Troubleshooting when error happens

(If the relative parts is normal, Error code display will be reset.)

1) F1 error

- Cause : Freezer sensor disconnection or short.
- Check point : Measure the resistance of freezer sensor in the Main PCB.

If sensor is disconnected or short, change that in the freezer compartment.

- Error code display



Freezer sensor is short.



Freezer sensor is disconnected.

2) R1 error

- Cause : Refrigerator sensor disconnection or short.
- Check point : Measure the resistance of refrigerator sensor in the Main PCB.

If sensor is disconnected or short, change that in the refrigerator compartment.

- Error code display



Refrigerator sensor is short.



Refrigerator sensor is disconnected.

3) rt error

- Cause : Room temperature sensor disconnection or short.
- Check point : Measure the voltage of sensor part on the Main PCB.

If voltage is 0.5~4.5V, normal. If voltage is 0V (short) or 5V (disconnect), change new one.

- Error code display



RT sensor is short.



RT sensor is disconnected.

4) d1 error

- Cause : Defrost sensor disconnection or short.
- Check point : Measure the resistance of defrosting sensor in the Main PCB.

If sensor is disconnected or short, change that on the evaporator.

- Error code display



Defrost sensor is short.



Defrost sensor is disconnected.

5) Door switch error (dr, dF, dH on display)

- Cause : When it senses the door open for more than 1 hour.
- Check point : Check the each door switch and exchange.

6) EI error

- Cause : Ice sensor is abnormal.
- Check point : Measure the resistance between both terminals after separating CN11 of the Main PCB.

If sensor is disconnected or short, change that in the automatic ice maker.

7) EF error

- Cause : When Flow-sensor abnormal. (There is no pulse during some time.)
The number of pulse signal is below 10 by 1 second during water supply.
- Check point : Water supply line.

8) Et error

- Cause : Level switch abnormal. (No pulse is sensed for some time.)
- Control : By time. (Supply mode is skipped.)

9) Eg error

- Cause : When Ice sensor temperature (5 minutes after water supply) doesn't go up.
- Check point : Ice sensor or water supply line.

10) EA error

- Cause : When sensing ice drop 3 times in level sensor switch error.
- Control : Stop ice maker
- After 1 time rotation EA error code disappear if level switch is normal.

11) Eu error

- Cause : Sensor which senses if ice is full or not is abnormal.
- Control : When drops the ice, the motor rotates 90 degree.

12) C1 error

- Cause : When compressor works for over 3 hours although Defrost sensor is over -5C.
- Check point : Refrigerant leakage.

13) F3 error

- Cause : in case defrosting mode ends after 60 minutes.
- Check point : Measure the resistance between both terminals of the defrost heater.
If the resistance is infinity (disconnection) or 0 ohm (short).

1. Ice making flow

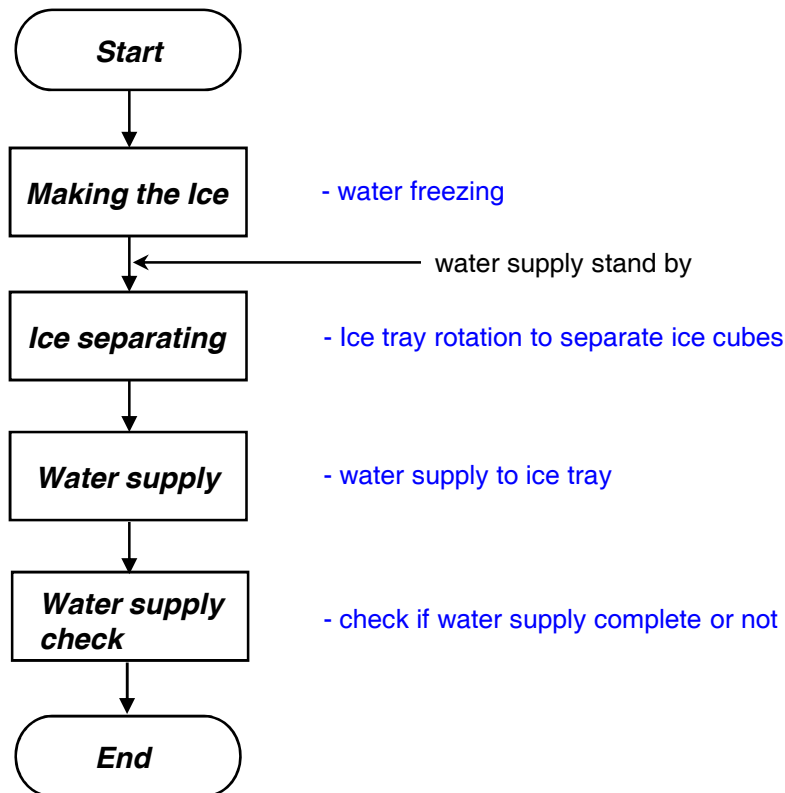

1) Press Test switch (which is under the ice tray) for more than 1 second and then test starts.

- Test mode starts from ice separating mode.
- In case test switch is abnormal, test is done only 1 time.

2) When the initial power input, ice tray turns to be horizontal.

3) Water supply hose heater control - defrost heater linkage operation

- Heater is always ON if Room temperature sensor is abnormal or room temperature is below 15 degree.
- Heater is ON for 60minutes (max limit time) if Flow sensor is abnormal.

4) Water supply stand by

- Condition : When ice is full
- Operation : Proceeds to ice making mode. (stop ice separating and water supply mode)

5) Crusher function

- It stops operation when freezer door is open.
- It operates if door is close.

2. Ice making mode

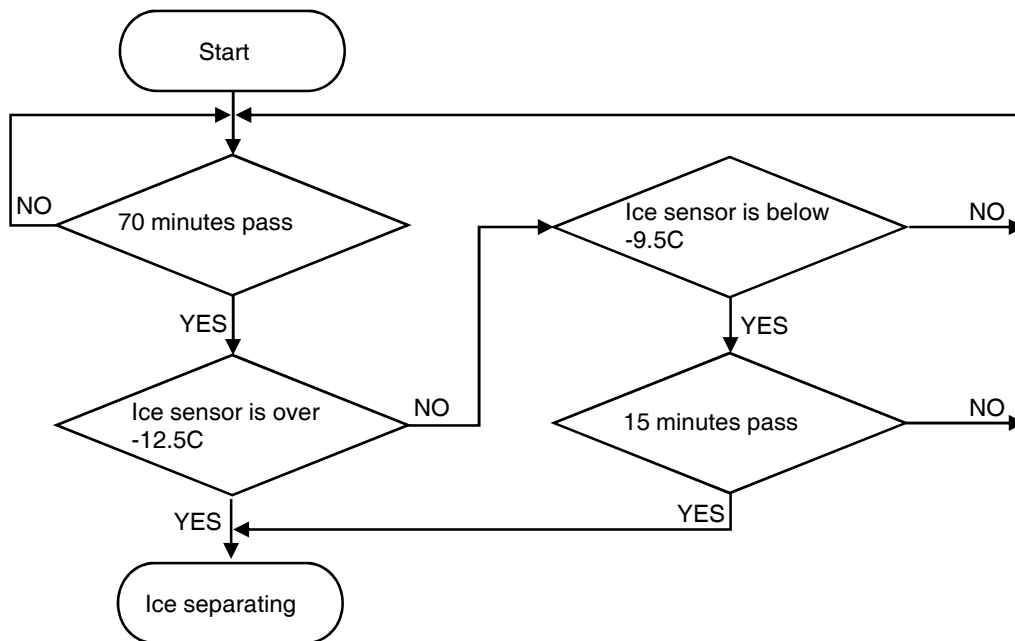

- 1) If Ice sensor temperature is below -12.5C after 70minutes, ice making completes.
- 2) If Ice sensor temperature keep below -9.5C for 15 minutes ice making complete, although the sensor is not below -12.5C
- 3) After 4.8hours ice making complete, when ice sensor is abnormal,

3. Ice separating(drop) mode

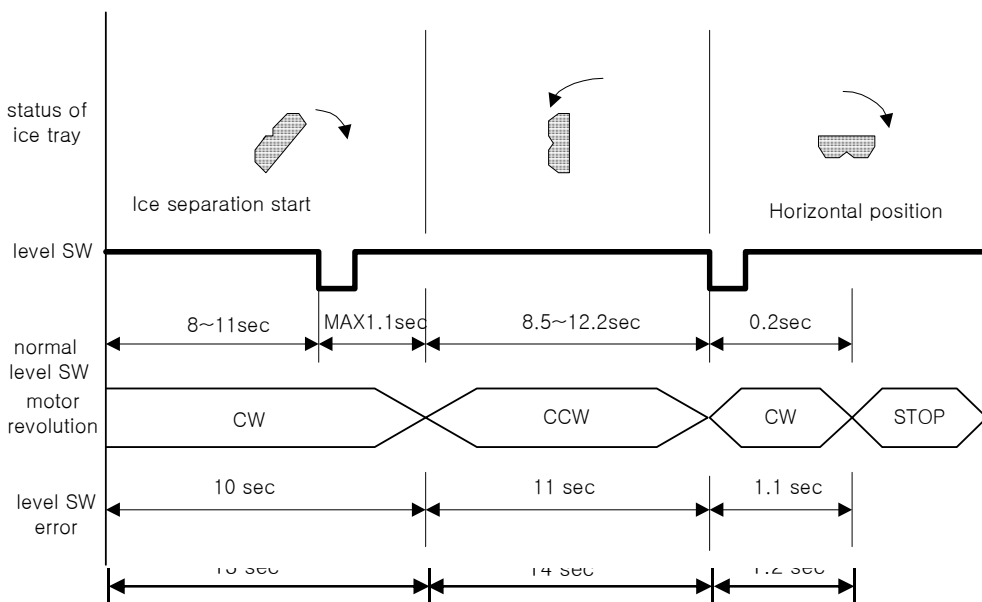

- 1) Time of each section is to verify level switch error.
- 2) It senses the rotation in each section.
- 3) When level switch is error, ice separation controlled by the time.
- 4) When rotation motor is error, the mode is pause.

4. Water supply mode

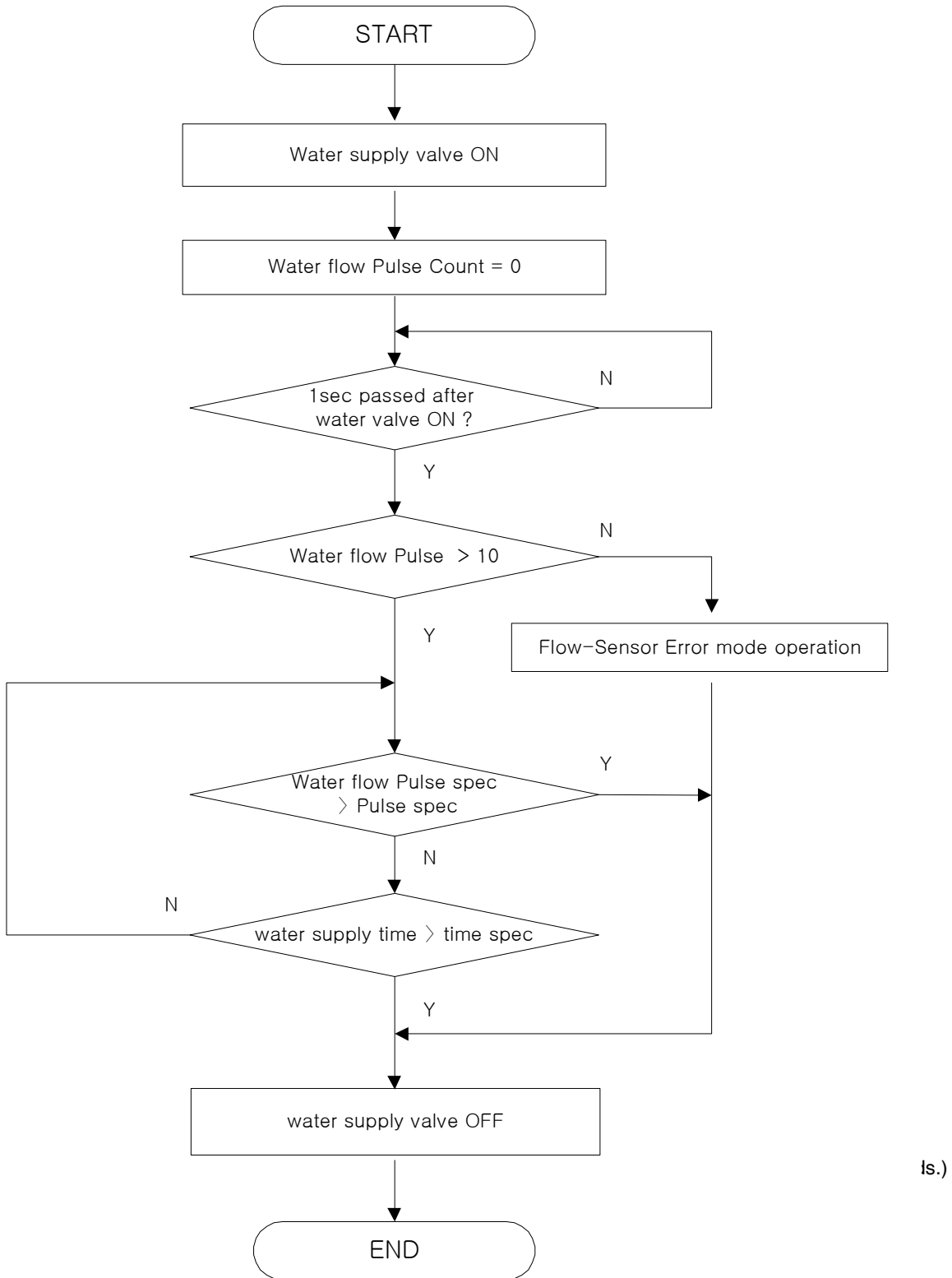

(s.)

Verify water supply completion by comparing room temperature sensor with ice sensor after 5 minutes from water supply.

Room temperature sensor	Below 9C	~ 15C	~ 21C	~ 31C	~ 41C	Over 41C
Ice sensor	-10C	-9C	-8C	-7C	-6C	-5C

5. Weak Cooling Trouble Shooting

; Adjust refrigerator sensor OFF point

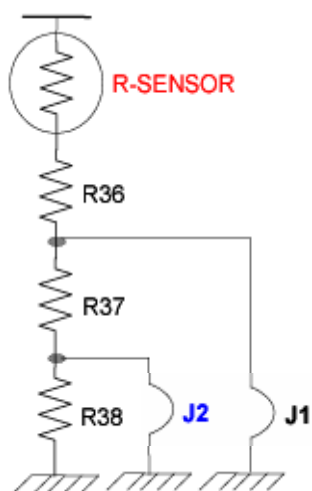

- Normal sensor resistance. (31.4kohm)
- Cut the J18 and increase sensor resistance. (33.4kohm)
- Cut the J18, J19 and increase resistance. (35.4kohm)

Option	Normal	Weak Cooling happens	
		1.5C down	3.0C down
J1	-	Cut	Cut
J2	-	-	Cut

6. Pull Down Mode

1) How to start

[Basic Model]

- Push the LOCK button.
- Push the LOCK button 10 times while keep pressing the REF.SET button.

[Dispenser Model]

- Push the LOCK button.
- Push the ICE button 5 times while keep pressing the REF.SET & FRZ.SET button.

2) How to control : Compressor, Freezer Fan, Refrigerator Fan and Compressor Cooling Fan is ON for 30 hours.

3) Display : **Co** display in Error Mode

4) Termination : After 30 hours or power reset.

7. How to check the filter running time (Dispenser Models Only)

1) In the Error Display.

2) Push the FRZ.SET button until display **Fi-Lt**.

3) Remaining time display when push the Dispenser button.

(ex. 40 : 12 means that 4012 minutes remains until exchange.)

8. System Off function

1) Purpose: Stop refrigerator operating without unplugging especially on holidays.

2) How to start : Pressing **FRZ.SET** and **REF.SET** button at the same time for 5 seconds will make the appliance turn off.

3) Under the 'off' mode Freezer and refrigerator temperature displays "- -".

Other LED lights go out and all the operation of your appliance halt.

4) Conversely pressing **FRZ.SET** and **REF.SET** button together for 5 seconds in order to switch back on.

9. Display Off function

1) 5 minutes after no buttons or doors are operated by customer, all the display LED except for;

[Basic Mode] : LOCK icon

[Dispenser Mode] : WATER, ICE or LOCK ICE which is selected by the user

2) Under the LED off status it returns to normal display mode when customers operate buttons or doors.

1. Basic Model

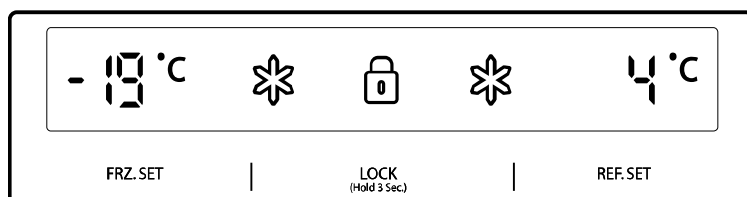

- All the modes active in LOCK condition (Push the LOCK button)

Mode	How to enter	Remark
A/S Forced Defrosting	REF.SET button 5 times while keep pressing FRZ.SET button.	
Pull Down	LOCK button 10 times while keep pressing REF.SET button.	
Error Display	LOCK button 5 times while keep pressing FRZ.SET button.	

2. Dispenser Model

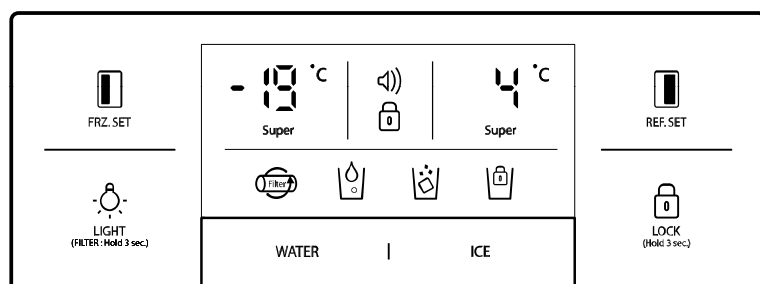

- All the modes active in LOCK (Push the LOCK button)

Mode	How to enter	Remark
A/S Forced Defrosting	REF.SET button 5 times while keep pressing FRZ.SET button.	
Pull Down	ICE button 5 times while keep pressing REF.SET & FRZ.SET button.	
Error Display	WATER button 5 times while keep pressing FRZ.SET button.	

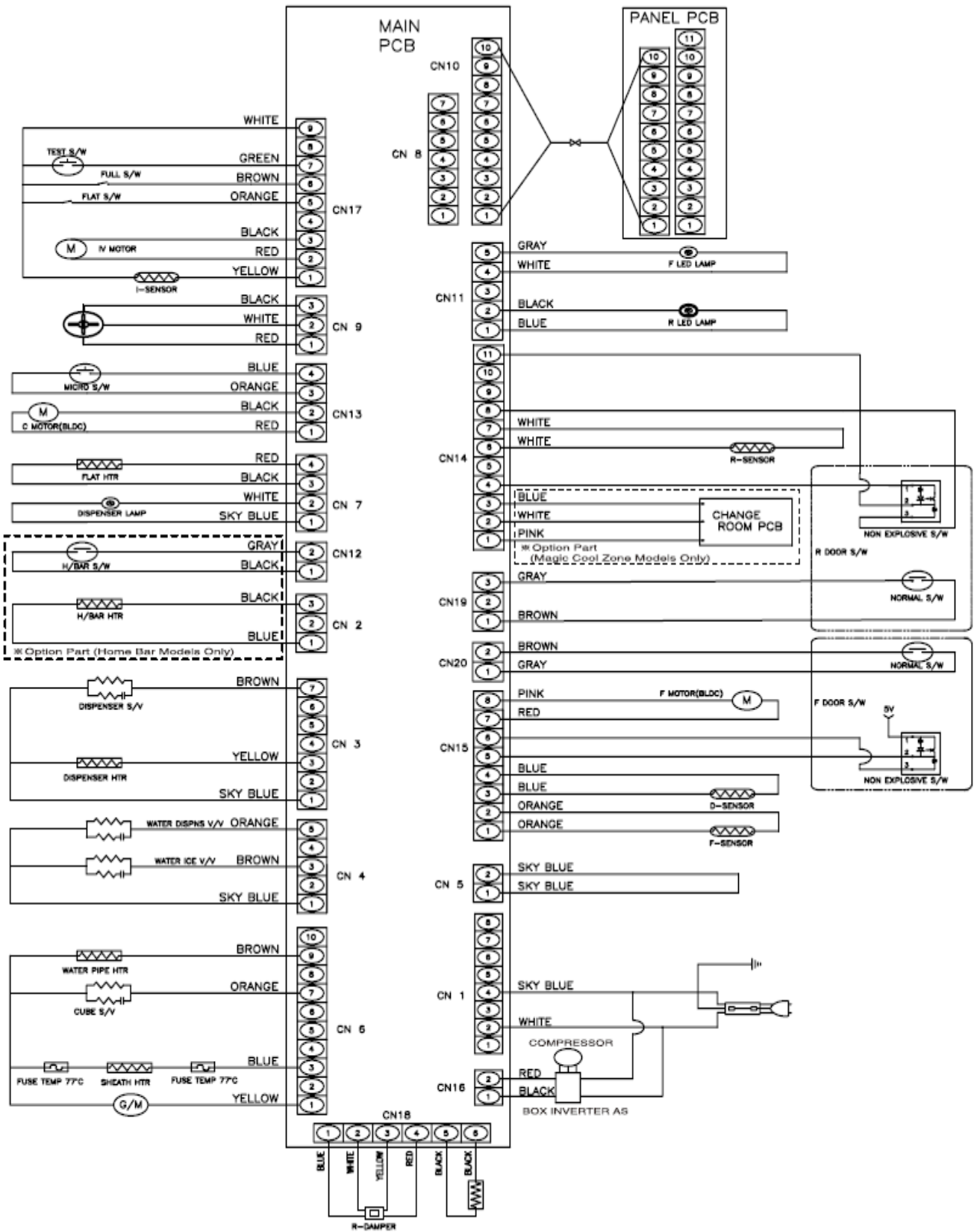

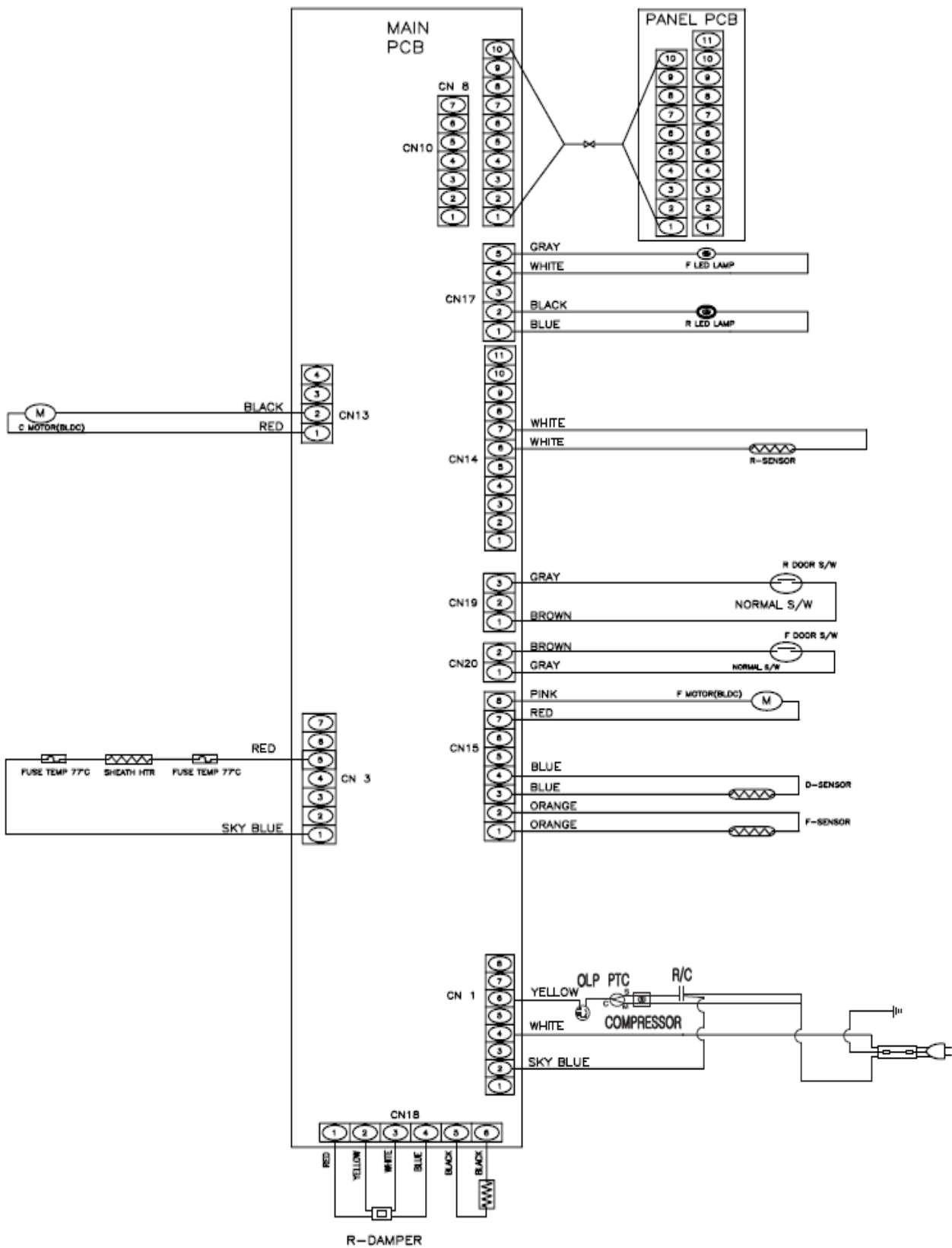

1. Inner lamp changing method

Disassembling Procedure

Freezer LED changing



Separate back side of a LED cover using (-) driver.



Separate LED cover and loosen 2 fixing screws for LED plate.



Disconnect harness of LED plate and change LED.

Refrigerator LED changing



Same as disassemble of a freezer.



Same as disassemble of a freezer.



Same as disassemble of a freezer.

Dispenser Type Freezer LED changing

◆ Separate Geared-Motor Box. (Refer 'Geared-Motor separation' part)



Separate back side of a LED cover located at bottom of Geared-Motor Box using (-) driver.



Separate cover and loosen 2 fixing screws for LED plate.



Disconnect harness from LED plate and change LED.

Ice maker changing



Loosen 2 fixing screws at roof of a freezer and pull a ice maker toward forward direction to separate it.



Disconnect harness connected to a ice maker and separate ice maker from a freezer.

Geared-Motor changing

◆ Separate ice maker.



Disconnect 2 kinds of harness which is connected with a Geared-Motor box at upper part of a freezer.



Loosen 4 fixing screws for a Geared-Motor box.

3.Freezer cooler area changing method

Disassembling Procedure

- ◆ Pull out food stuffs and rack inside of a freezer

Separate cooler fan cover – Dispenser Model

- ◆ Separate ice maker & Geared-Motor box.



Separate heater housing for water supply pipes.



Loosen fixing screw for a fan cover of a cooler.



Separate cover & water supply port (silicon rubber) by loosening screw at cover of a water supply pipe at back side of a refrigerator.



Grip cooling air discharge port at fan cover of a cooler by hand and separate it from lock.



Push back a water supply pipe located at back side of a freezer and go to back side of a refrigerator and pull out a water supply pipe.



Lift up right side of a cooler fan cover to forward direction and tilt it to disconnect and pull out fan harness located at left side of a cooler fan cover.



Remove screw cap of a fan cover located at upper rear side of a freezer.



Separate fan cover of a cooler.

4. Cooler fan / Fan separation

Disassembling Procedure

Cooler fan / Fan motor separation

◆ Separate cooler fan cover.



Loosen 4 fixing screws for a fixture f motor located at rear side of a cooler fan cover.

Separate 4 hooks to separate a fixture f motor.



Pull out fan assembled at inner side of a fixture fan motor to vertical direction. [Fan separation]

Fan fixing rings are fixed with lock tight. (Kinds of bond)

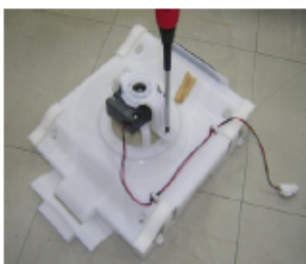

Loosen 2 fixing screws for fixture f motor B from back side of a fixture fan motor.



Motor can be separated by separation of a fixture f motor B.

Caution when disassemble/assemble fan & fan motor.

- Assemble motor so that there is no tilt or loosening. (To prohibit noise generating problem)
- When fixing a fan, fix it using fan fixing rings to protect moving or separation and apply lock tight. (Kinds of bond)
- After fixing a fan, rotates fan by hand to check interference with surrounding parts. When there is interference with surrounding parts, fix fan or motor again.

Disassemble drawing for fan & fan motor

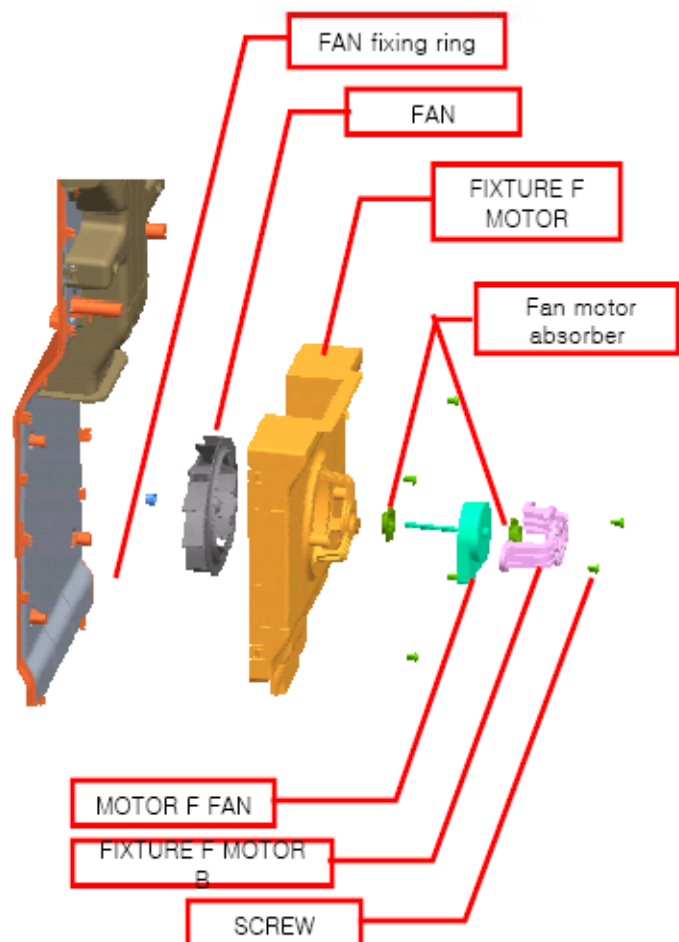

5. Cooler front cover separation

Disassembling Procedure



Remove a screw cap at center of a return cover located at bottom of a cooler front cover.



Loosen a screw at center of a return cover.



Separate hooks using (-) driver by twisting it which is assembled at return cover and front cover.



Pull upper part of a return cover and press it to downwards.

Separate a return cover through bottom of a freezer.



Grip upper part of a duct cover which is assembled at center of a cooler front cover and pull it out to forward direction to separate.



Loosen a fixing screw at cooler front cover.



Grip upper part of a cooler front cover by hand and pull it forward direction to separate it.



Figure of a freezer room after cooler front cover is removed.

Evaporator in detail

cooler(EVA)



cooler housing connection



D-sensor housing

Defrost heater +temp. fuse housing



D-sensor

Temp. fuse



EVA upper area

Defrost heater



EVA bottom area

6. Refrigerator Damper changing method

Disassembling Procedure

- ◆ Pull out food stuffs and rack from refrigerator .

Damper cover disassemble



Open window of a damper cover and bend it lightly at center part to separate window.







Loosen 2 screws inside of a damper cover.

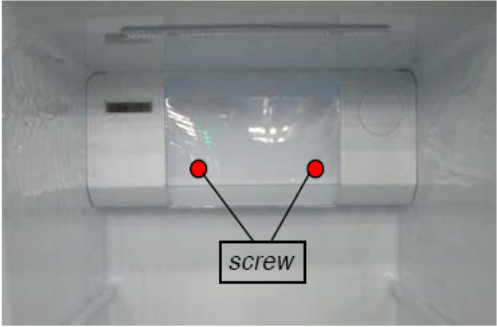
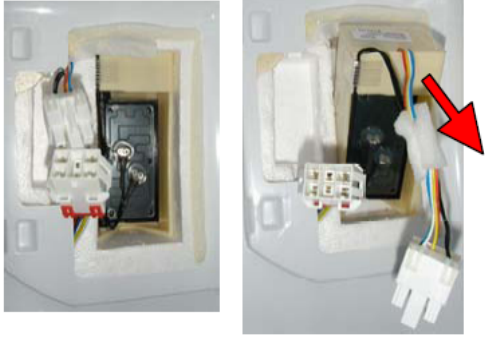
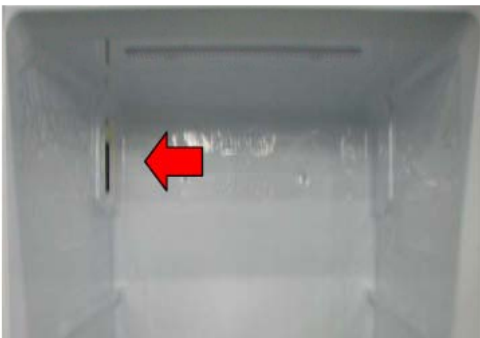

Grip lower side of a damper cover and pull it forward to separate it.

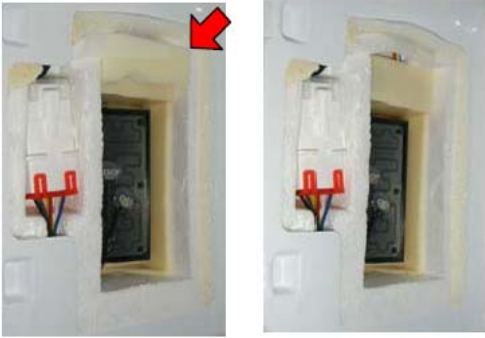
7. Refrigerator Damper changing method

No	Procedure	No	Procedure
1	 <p>Remove the R Damper As. (Unscrew 2 point with + driver.)</p>	4	 <p>Disconnect and pull out. (Be careful not to damage the styrofoam.)</p>
2	 <p>You can see the electric damper on the left.</p>	5	 <p>Exchange the new damper.</p>
3	 <p>Peel off tape and sealing substance.</p>	6	 <p>After exchange sealing tightly for better performance.</p>

8. C-Fan Motor changing method

Disassembling Procedure



C-Fan motor housing

Bell mouth



Separate C-fan motor housing at upper right part of a machine room.



Push and pull forward lock of a bell mouth and separate bell mouth ass'y. (Be careful blade of a fan not to be deformed during disassemble)



Loosen screws at upper, lower part of a bell mouth.



Separate a blade of a fan from a C-Fan motor shaft.



Loosen screws of a motor cover and separate cover and pull out C-fan motor.



Make a space to pull out bell mouth by pushing dryer lightly which is located in front of a bell mouth to a compressor side.

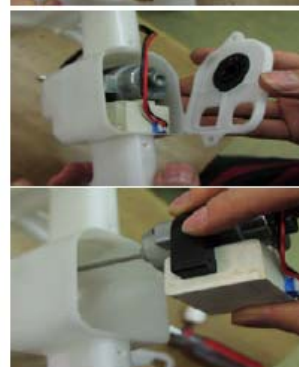

1. Faulty Start (Lights OFF, Front PCB Power Dead)

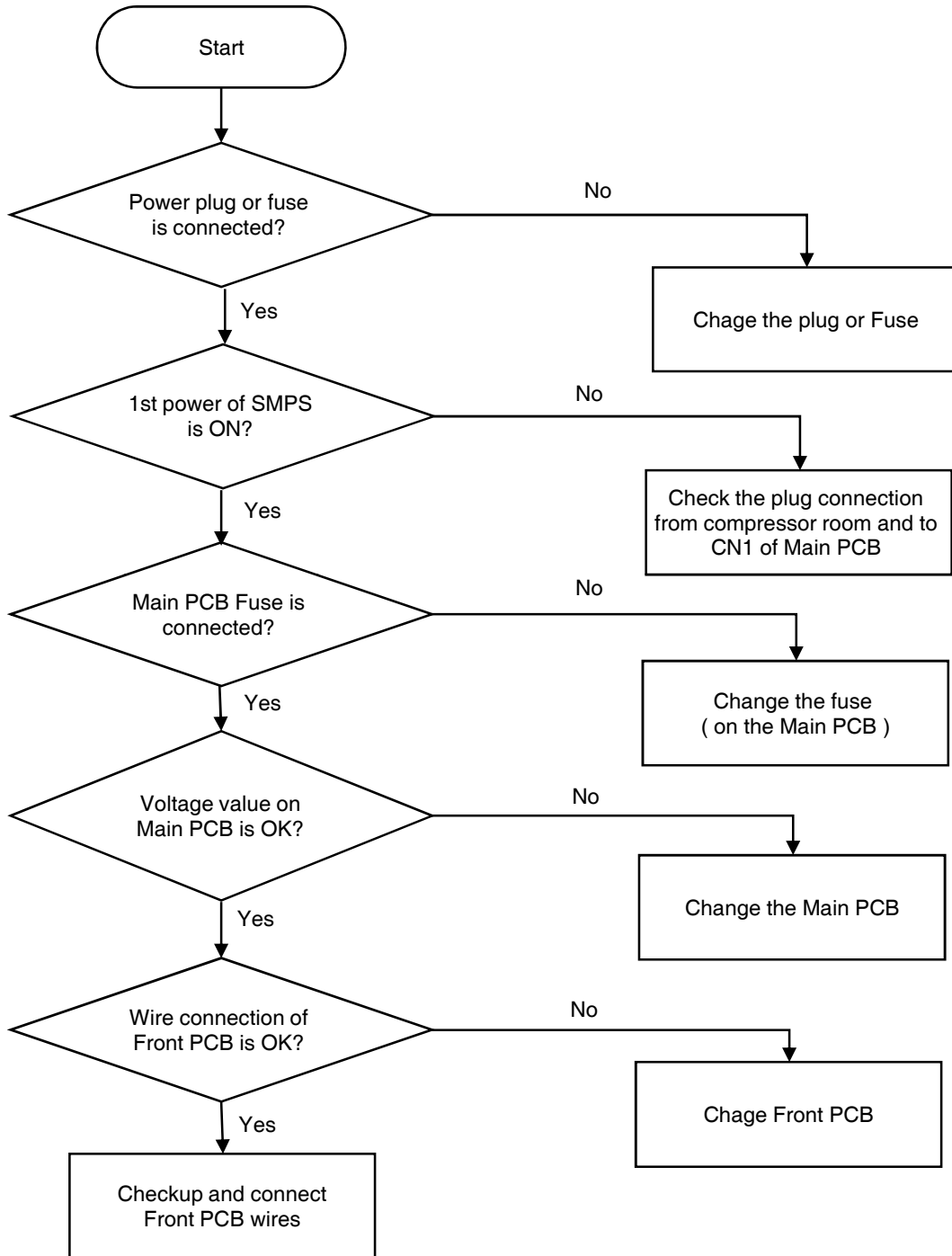

2. Freezing or cooling failure (Weak cooling)

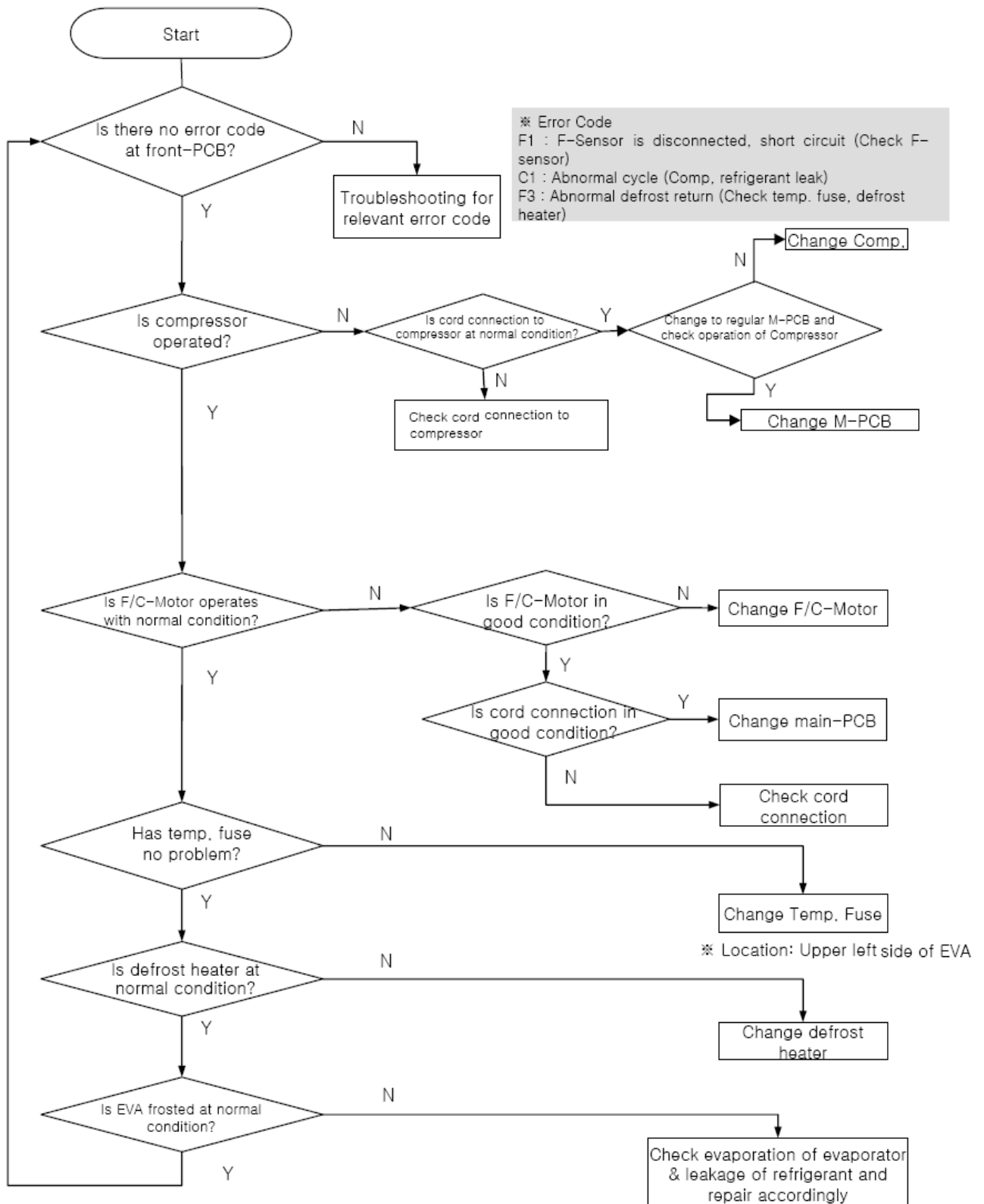

3. Ice formation on Freezer Louver

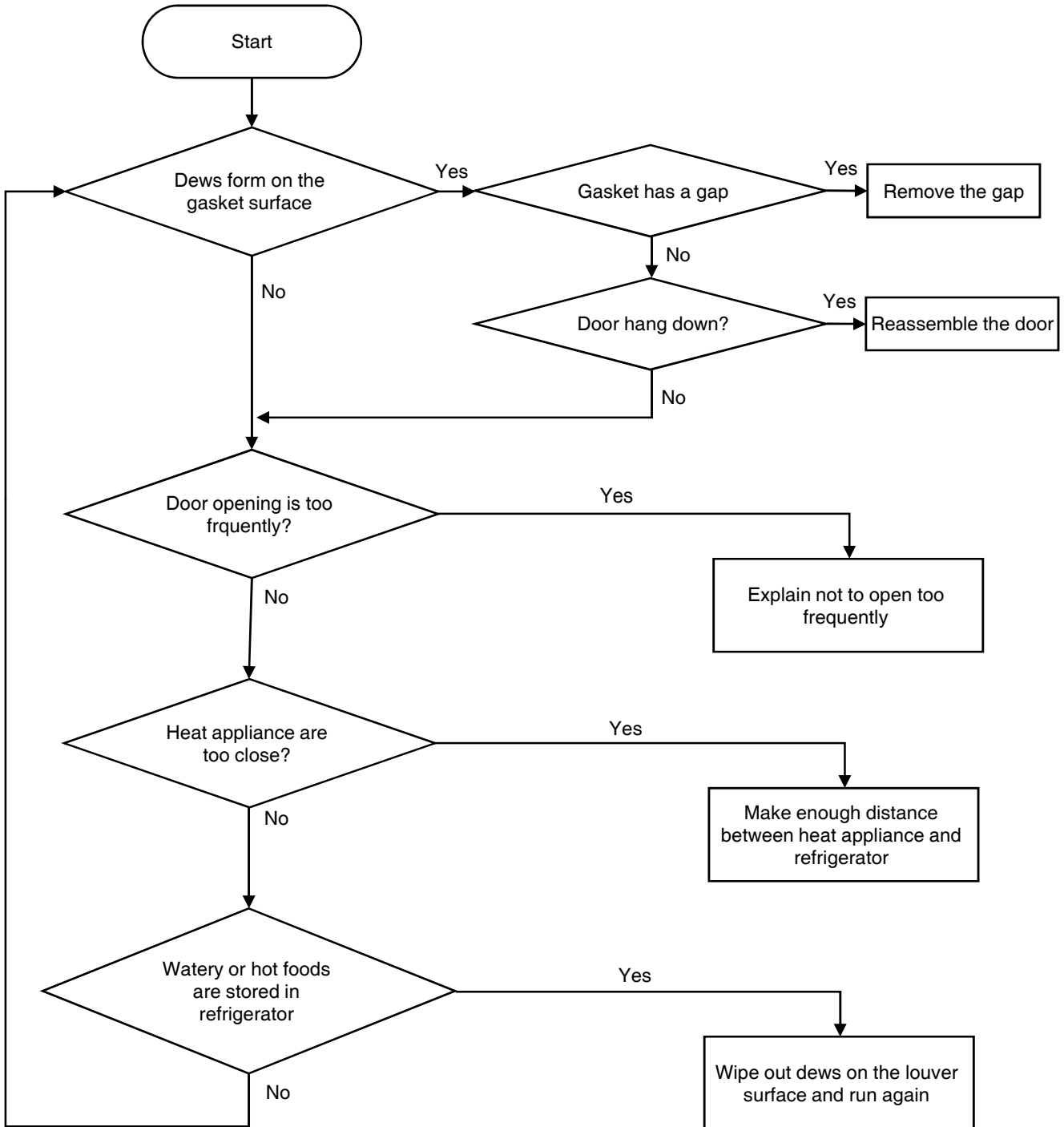

4. Disconnection / Breaking of Interior Lights Wire

4-1. Freezer Door

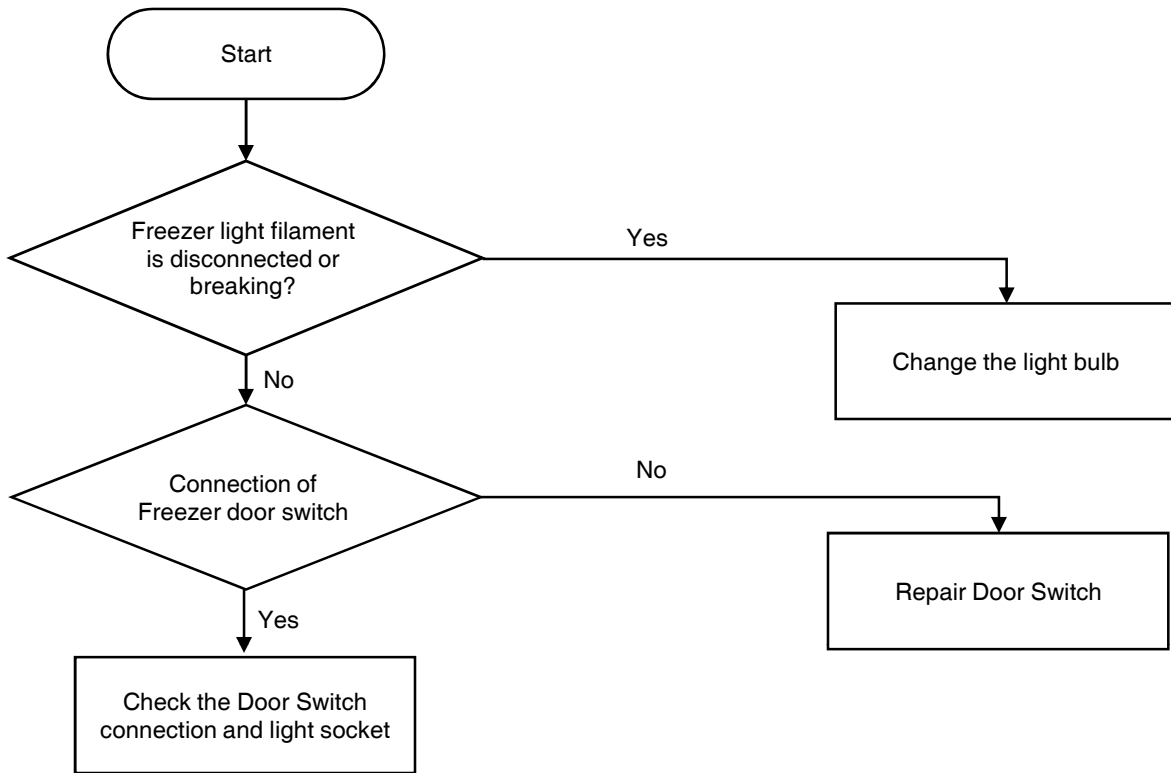

4-2. Refrigerator Door

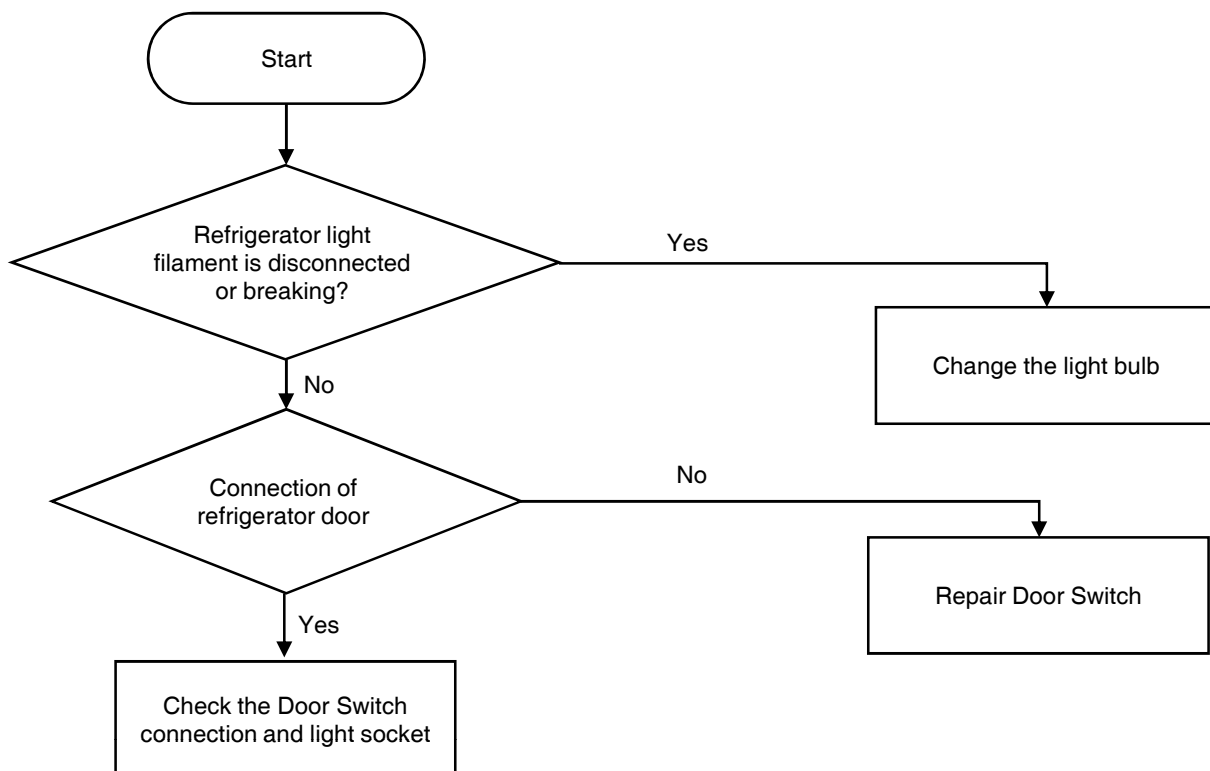

6. Dews on Refrigerator Compartment

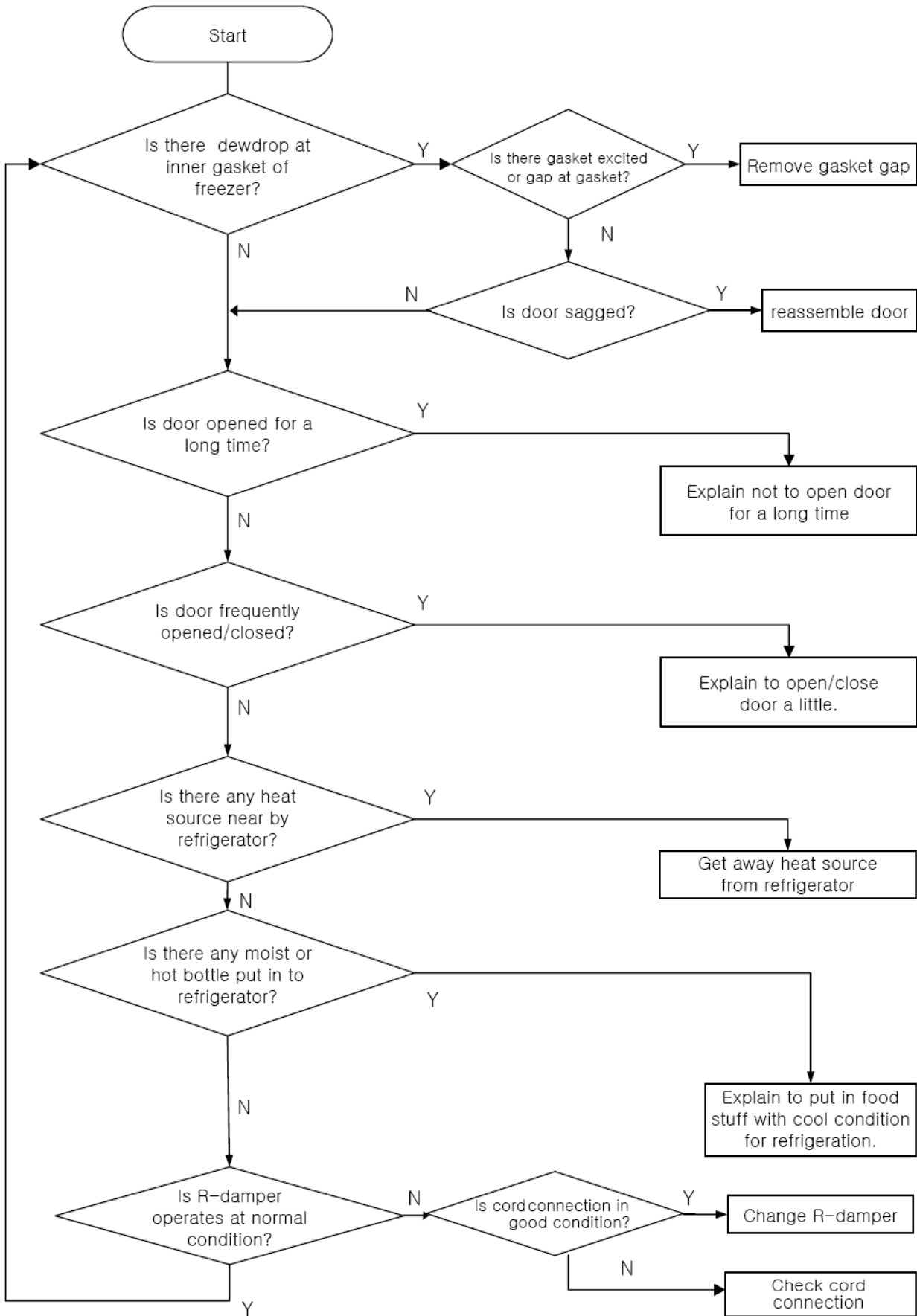

5. Refrigeration failure (Foods does not get cool or cold soon)

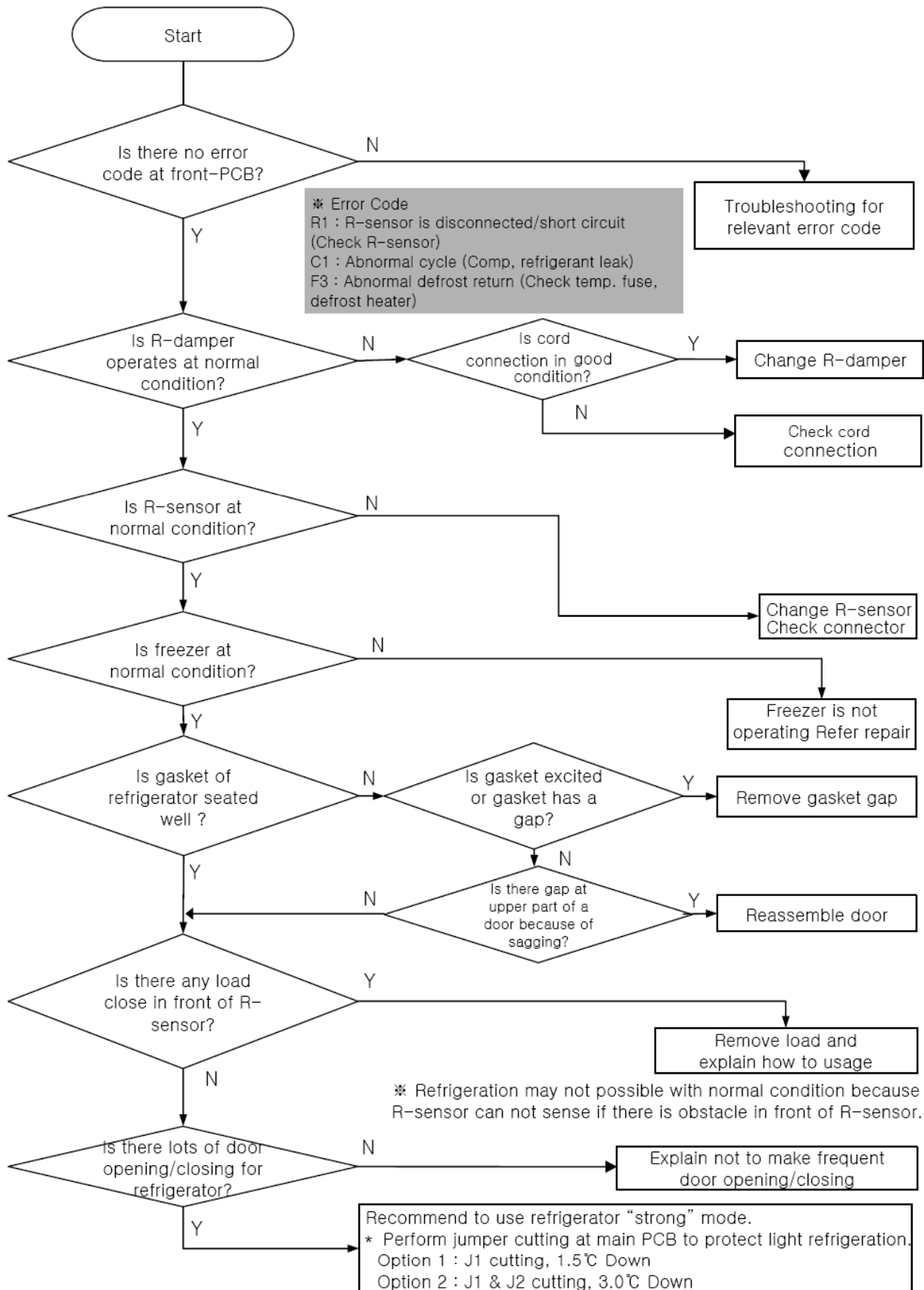

7. Cold of Vegetable Case

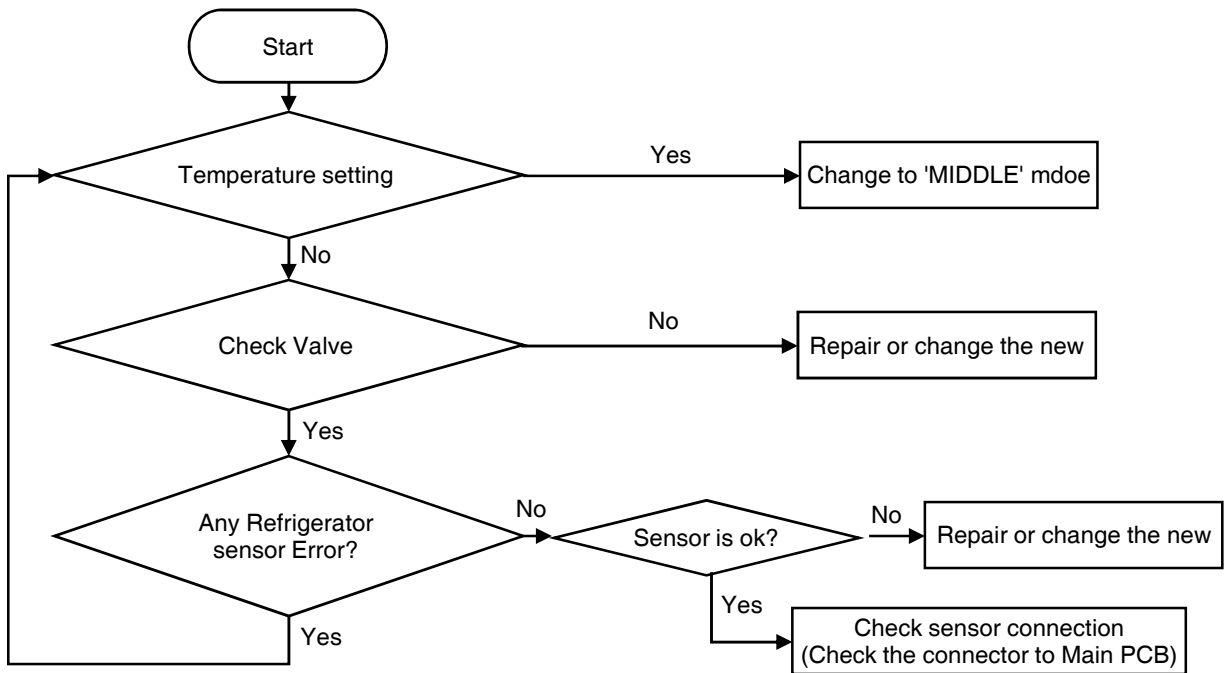
**Remark**

- Compressor sound is somewhat normal because it works like a heart to circulate the refrigerant in the pipes.
- Rattling or metallic touch sound of motor, piston of compressor can be heard when it starts or stops.

8. Operation Noise of Refrigerator

8-1. Refrigerant Flow Sound

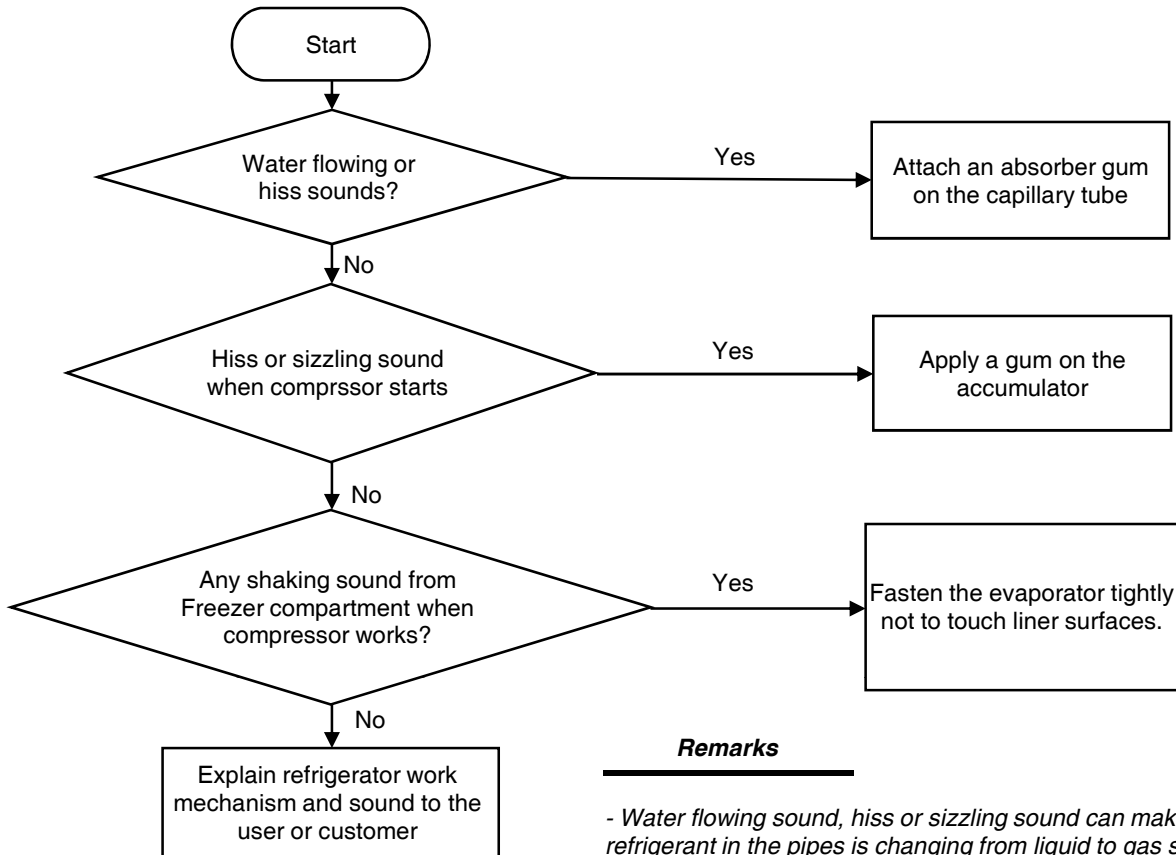

Remarks

- Water flowing sound, hiss or sizzling sound can make while refrigerant in the pipes is changing from liquid to gas state when compressor starts or stops.
- It is normal sound.

8-2. Fan Noise

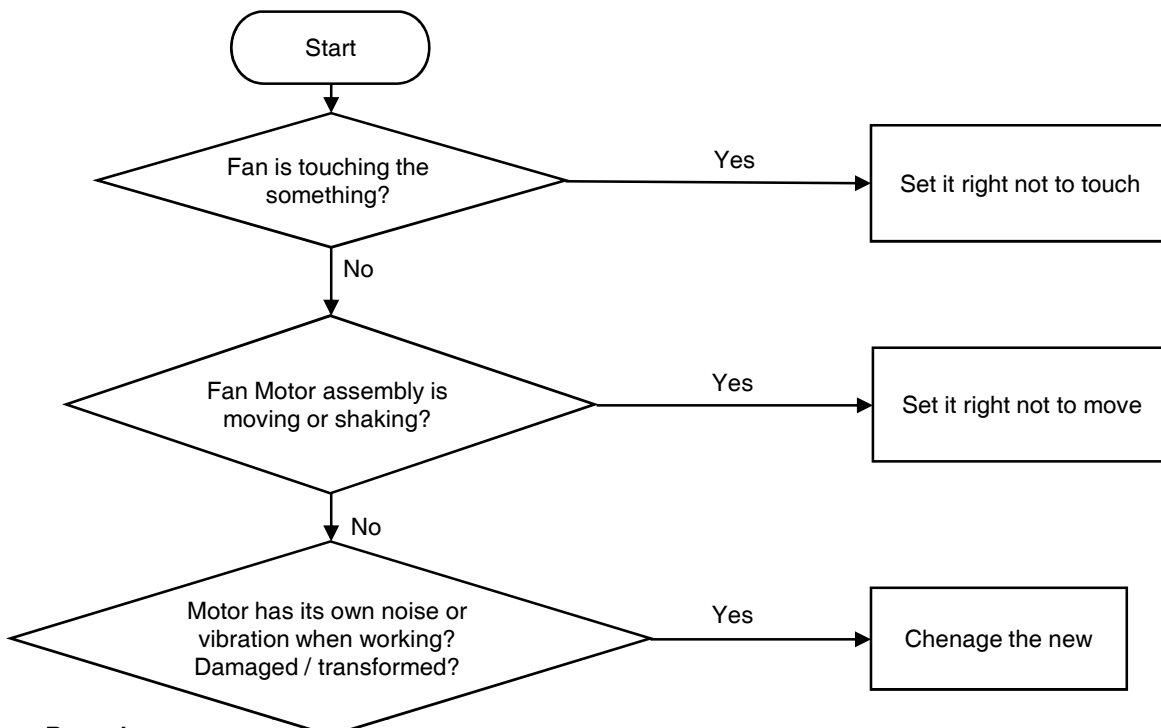

Remarks

- The fan is sending out cold air to circulate each corner of the compartment.
- When the air is touching the surface of louver or liner wall, such sound can make.

8-3. Pipe Noise

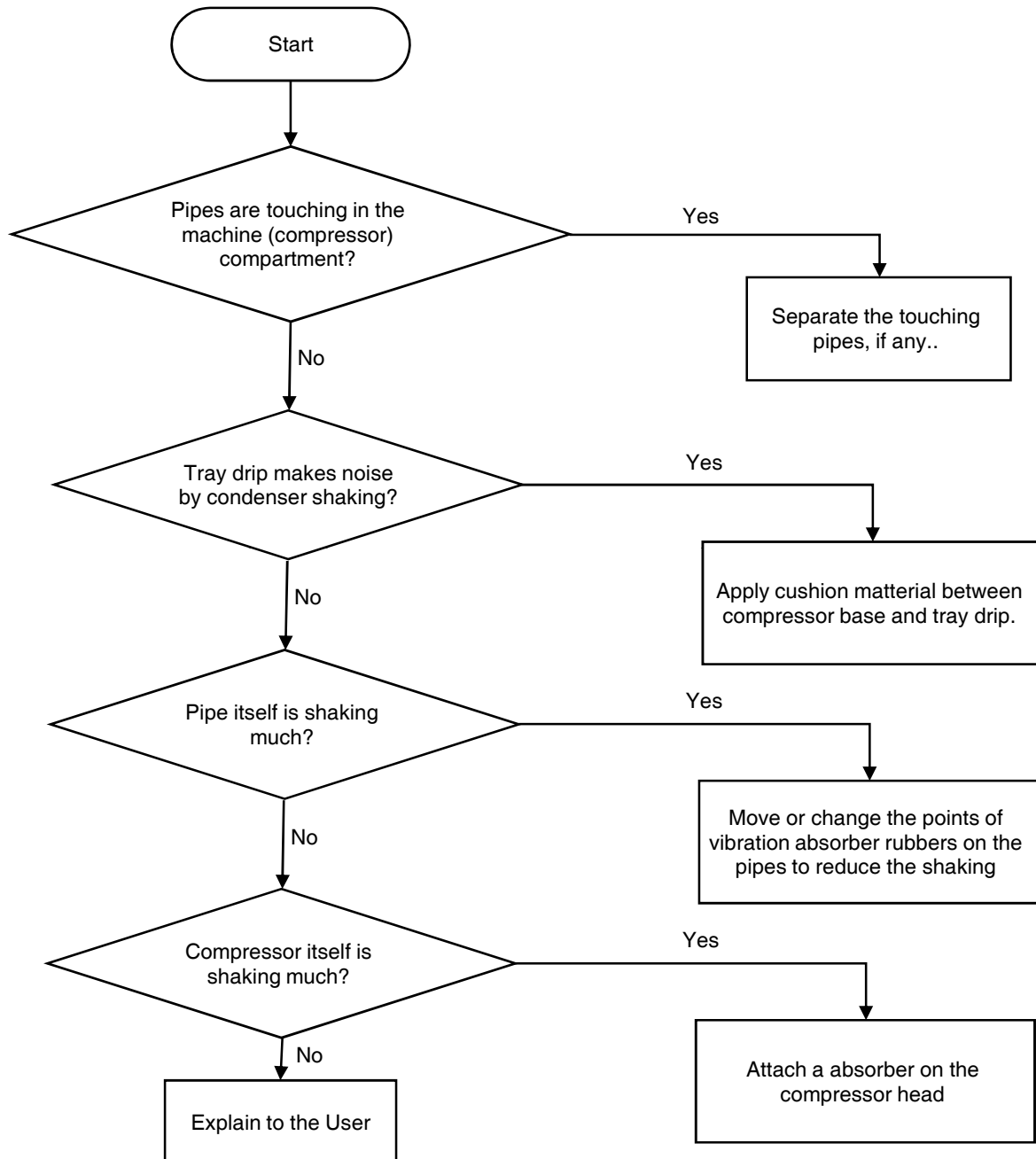
**Remarks**

- Refrigerant is erupting rapidly from the compressor to circulate pipes, so pipe shaking noise can make to some degree.
- In case compressor vibration is sent to a pipe directly, apply vibration absorber rubbers to welding pionts of pipepe and comprrsor or to a much bent piont on the pipe.

9. Door opening alarm continues after closing

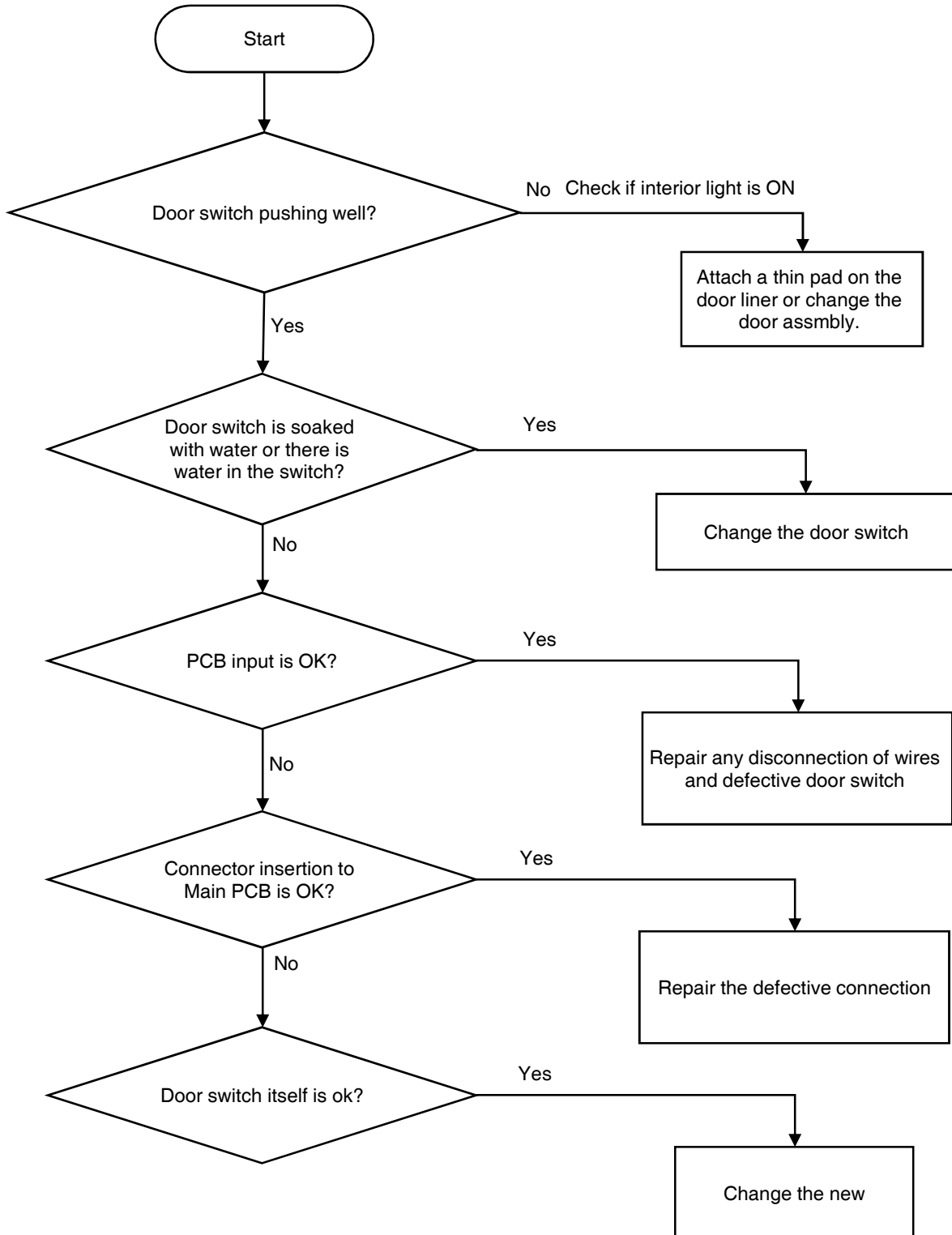

1. Summary of Heavy Repair

Process	Contents	Tools
Remove refrigerant Residuals	Cut charging pipe ends (Comp. & Dryer) and discharge refrigerant from drier and compressor.	Nipper, side cutters
Parts replacement and welding	Confirm refrigerant (R-134a or R-600a) and oil for compressor and drier. Confirm N2 sealing and packing conditions before use. Use good one for welding and assembly. Weld under nitrogen gas atmosphere. Repair in a clean and dry place.	Pipe Cutter, Gas welder, N2 gas
Vacuum	Evacuate for more than forty minutes after connecting manifold gauge hose and vacuum pump to high (drier) and low (compressor) pressure sides.	Vacuum pump , Manifold gauge.
Refrigerant charging and charging inlet welding	Weigh and control the bombe in a vacuum conditions with electronic scales and charge through compressor inlet (Process tube). Charge while refrigerator operates). Weld carefully after inlet pinching.	Bombe (mass cylinder), refrigerant manifold gauge, electronic scales, punching off flier, gas welding machine
Check refrigerant leak and cooling capacity	Check leak at weld joints. Note :Do not use soapy water for check. Check cooling capacity - Check condenser manually to see if warm. - Check hot pipe manually to see if warm. - Check frost formation on the whole surface of the evaporator.	Electronic Leak Detector, Driver.
Compressor compartment and tools arrangement	Remove flux from the silver weld joints with soft brusher wet rag. (Flux may be the cause of corrosion and leaks.) Clean tools and store them in a clean tool box or in their place.	Copper brush, Rag, Tool box
Transportation and installation	Installation should be conducted in accordance with the standard installation procedure. (Leave space of more than 5 cm from the wall for compressor compartment cooling fan mounted model.)	

2. Precautions During Heavy Repair

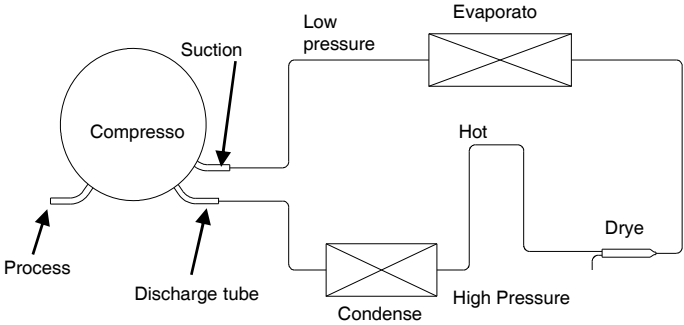
Items	Precautions
Use of tools.	- Use special parts and tools for R-134a or R-600a.
Removal of retained refrigerant.	<p>1) Remove retained refrigerant more than 5 minutes after turning off a refrigerator. (If not, oil will leak inside.)</p> <p>2) Remove retained refrigerant by cutting first high pressure side (drier part) with a nipper and then cut low pressure side. (If the order is not observed, oil leak will happen.)</p> 
Replacement of drier.	- Be sure to replace drier when repairing pipes and injecting refrigerant.
Nitrogen blowing welding.	- Weld under nitrogen atmosphere in order to prevent oxidation inside a pipe. (Nitrogen pressure : 0.1~0.2 kg/cm2.)
Others.	<p>1) Nitrogen only should be used when cleaning inside of cycle pipes inside and sealing.</p> <p>2) Check leakage with an electronic leakage tester.</p> <p>3) Be sure to use a pipe cutter when cutting pipes.</p> <p>4) Be careful not the water let intrude into the inside of the cycle.</p>

3. Practical Work for Heavy Repair

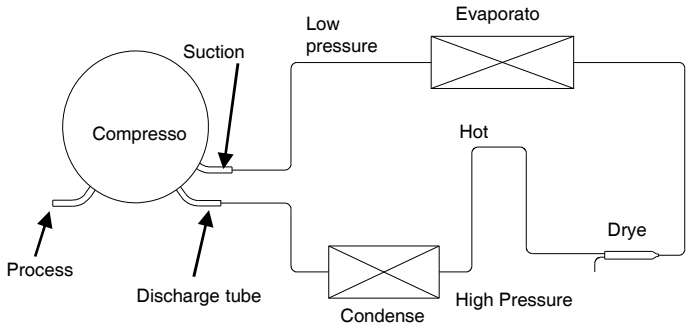
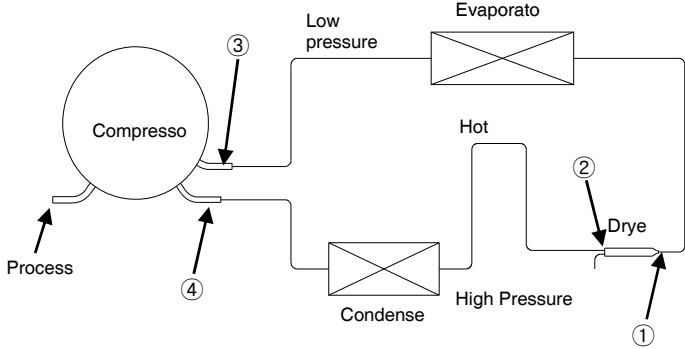
Items	Precautions
<p>1. Removal of residual refrigerant.</p>	<p>1) Remove residual refrigerant more than 5 minutes later after turning off the refrigerator. (If not, compressor oil may leak inside.) 2) Remove retained refrigerant slowly by cutting first high pressure side (drier part) with a nipper and then cut low pressure side.</p> 
<p>2. Nitrogen blowing welding.</p>	 <p>* When replacing a drier: Weld 1 and 2 parts by blowing nitrogen (0.1~0.2kg/cm²) to high pressure side after assembling a drier.</p> <p>* When replacing a compressor: Weld 3 and 4 parts by blowing nitrogen to the low pressure side. Note) For other parts, nitrogen blowing is not necessary because it does not produce oxidized scales inside pipe because of its short welding time.</p> <p>- KEYPOINTING Welding without nitrogen blowing produces oxidized scales inside a pipe, Which affect on performance and reliability of a product.</p>

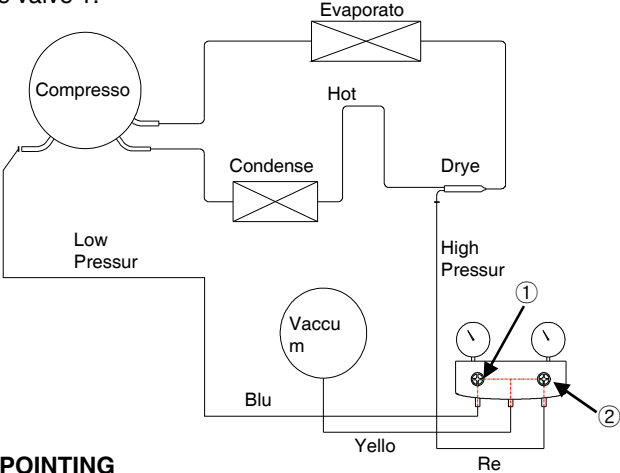
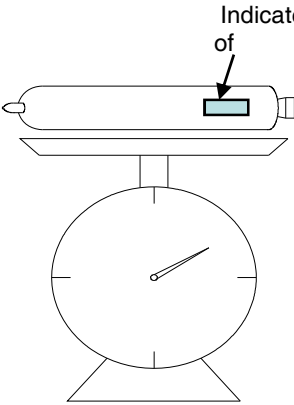
Items	Precautions
<p>3.Vacuum degassing</p>	<p>* Pipe Connection Connect a red hose to the high pressure side and a blue hose to the low pressure side.</p> <p>* Vacuum Sequence Open 1,2 valves and evacuate for 40 minutes. Close valve 1.</p>  <p>KEYPOINTING</p> <ol style="list-style-type: none"> 1) If power is applied during vacuum degassing, vacuum degassing shall be more effective. 2) Operate compressor while charging refrigerant. (It is easier and more certain to do like this.)
<p>4.Refrigerant charging</p>	<p>* Charging sequence</p> <ol style="list-style-type: none"> 1) Check the amount of refrigerant supplied to each model after completing vacuum degassing. 2) Evacuate bombe with a vacuum pump. 3) Measure the amount of refrigerant charged. <ul style="list-style-type: none"> - Measure the weight of an evacuated bombe with an electronic scale. - Charge refrigerant into a bombe and measure the weight. Calculate the weight of refrigerant charged into the bombe by subtracting the weight of an evacuated bombe.  <p>- KEYPOINTING</p> <ol style="list-style-type: none"> 1) Be sure to charge the refrigerant at around 25C. 2) Be sure to keep -5g in the winter and +5g in summer. <p>Calculation of amount of refrigerant</p> <p>the amount of refrigerant charged = a weight after charging - a weight before charging (a weight of an evacuated cylinder)</p>

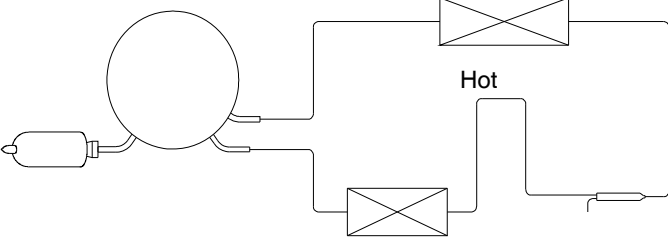
Item	Precautions
<p>4. Refrigerant charging</p>	<p>4) Refrigerant Charging Charge refrigerant while operating a compressor as shown above. 5) Pinch a charging pipe with a pinch-off plier after completion of charging. 6) Braze the end of a pinched charging pipe with copper brazer and take a gas leakage test on the welded parts.</p> 
<p>5. Gas-leakage test</p>	<p>* Take a leakage test on the welded or suspicious area with an electronic leakage tester.</p>
<p>6. Pipe arrangement in each cycle</p>	<p>* Check each pipe is placed in its original place before closing a cover back-M/C after completion of work.</p>

< Standard Regulations for Heavy Repair >

- 1) Observe the safety precautions for gas handling.
- 2) Use JIG (or wet towel) in order to prevent electric wires from burning during welding.
(In order to prevent insulation break and accident.)
- 3) The inner case shall be melted and insulation material (polyurethane) shall be burnt if not cared during welding inner case parts.
- 4) The copper pipe shall be oxidized by overheating if not cared during welding.
- 5) Not allow the aluminum pipes to contact to copper pipes. (In order to prevent corrosion.)
- 6) Make sure that the inner diameter should not be distorted while cutting a capillary tube.
- 7) Be sure that a suction pipe and a filling tube should not be substituted each other during welding.
(High efficiency pump.)

Brzing Reference Drawings

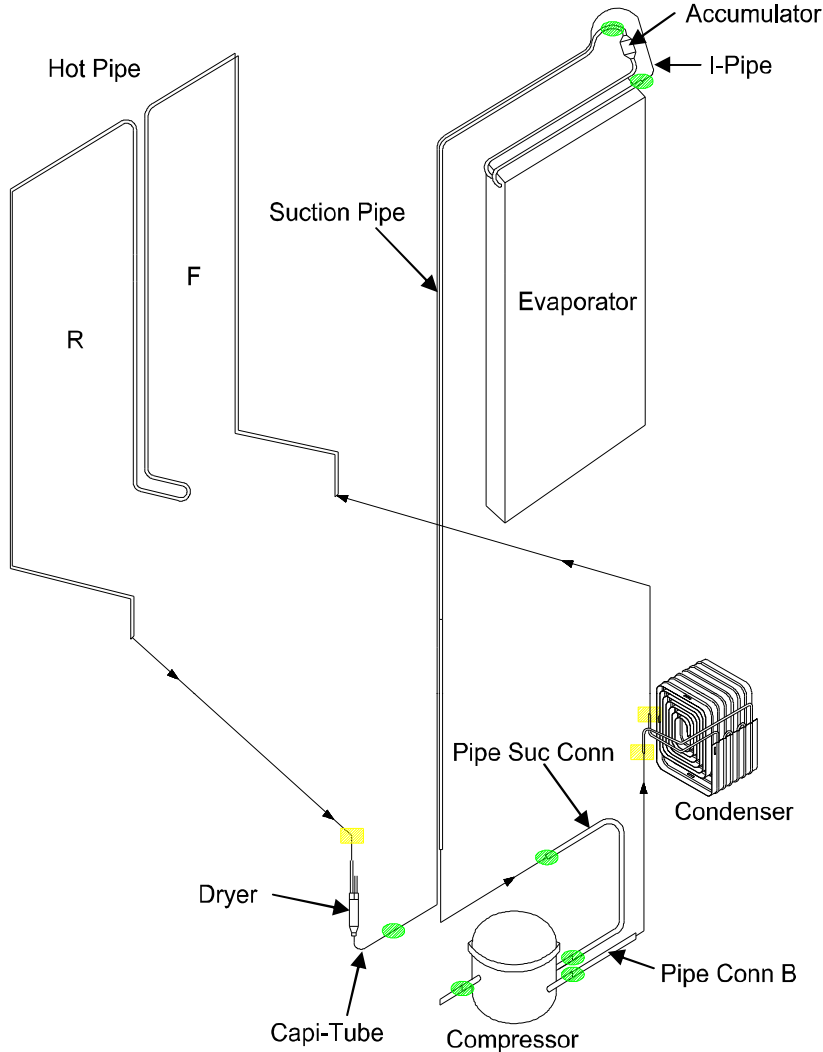

► Welding Point

●	Copper Welding (Ag 5%)	7 Points
■	Silver Welding (Ag 35%)	3 Points

► Flow of Refrigeration Cycle

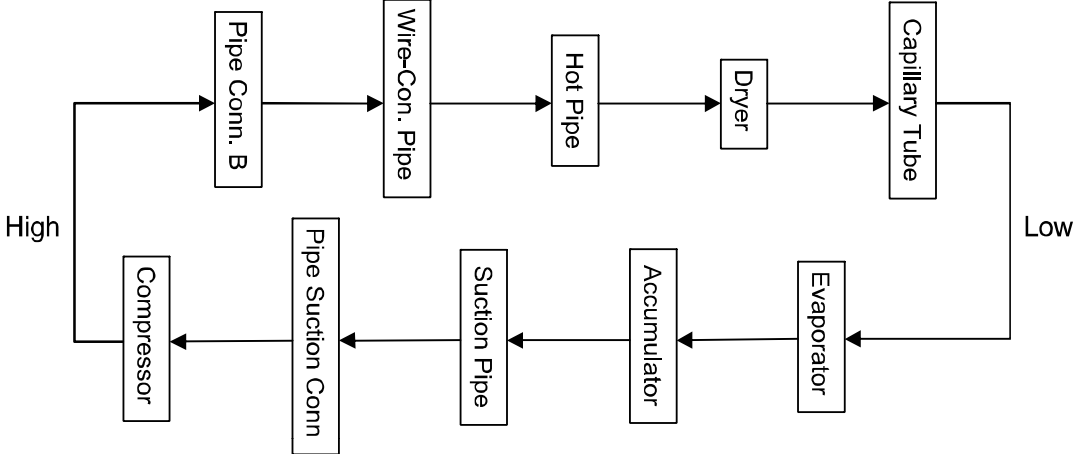

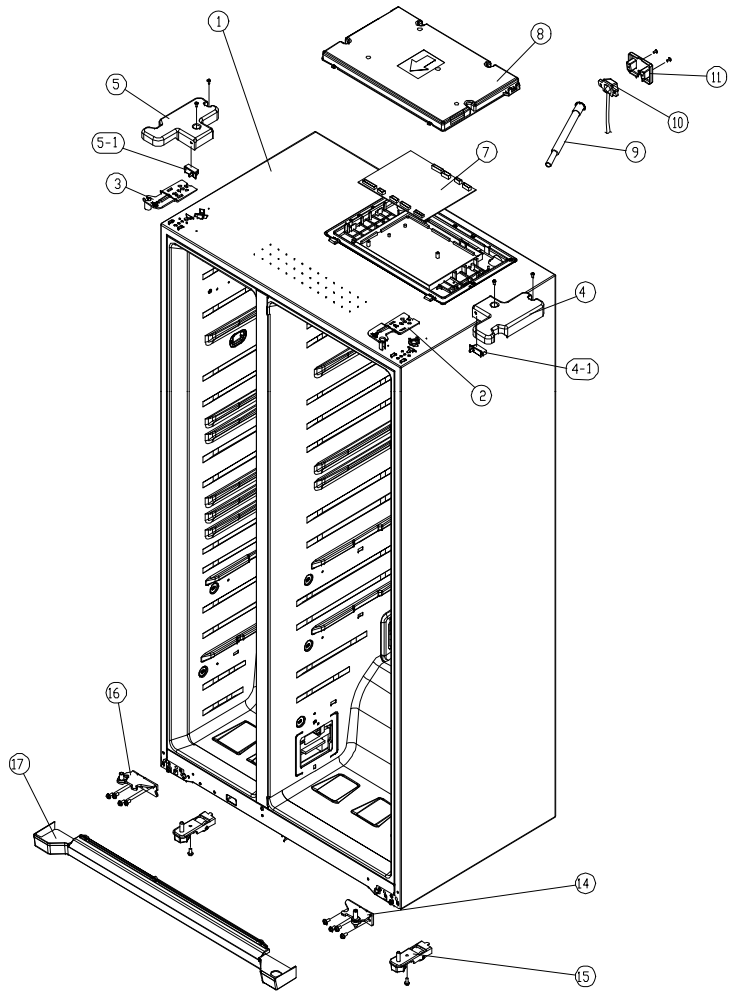

NO	PART-CODE	PART NAME	SPEC.	Q'ty		
				Basic	I & W	I & W + H/bar
1	-	ASSY CAB URT	-	1	1	1
2	3012933100	HINGE *T *R	PO T3.0+PAINT	1	1	1
3	3012933000	HINGE *T *L	PO T3.0+PAINT	1	1	1
4	3001436800	COVER HI *T *R AS	PP + SWITCH	1	1	1
4-1	30128125601	SWITCH H/BAR DR AS	SP101B-2DI	1	1	1
5	3001436700	COVER HI *T *L AS	PP + SWITCH	1	1	1
5-1	30128125601	SWITCH H/BAR DR AS	SP101B-2DI	2	2	2
7	3014HR070	PCB MAIN AS	FRX-621B..	1	x	x
	30143HJ080		FRX-601D..(Inverter Comp.)	x	1	x
	30143HJ060		FRX-601F..(Inverter Comp.)	x	x	1
8	3011446001	COVER M/PCB BOX	PP(FB-72)	1	1	1
9	3013226800	HOSE ICE MAKER TUBE AS	220~240V/5W	x	x	1
10	3012540200	GUIDE CAB W/TUBE A AS	X22.. MODEL	x	x	1
11	3001428611	COVER GUIDE CAB W/TUBE AS	PP	x	x	1
14	3012933500	HINGE *U *R AS		1	1	1
15	3010673800	BRACKET ADJ FT AS		2	2	2
16	3012933400	HINGE *U *L AS		1	1	1
17	3001440200	COVER CAB BRKT AS	PP	1	1	1

- Some parts can be chaged for improving their performance without notice.

No	Date	Note

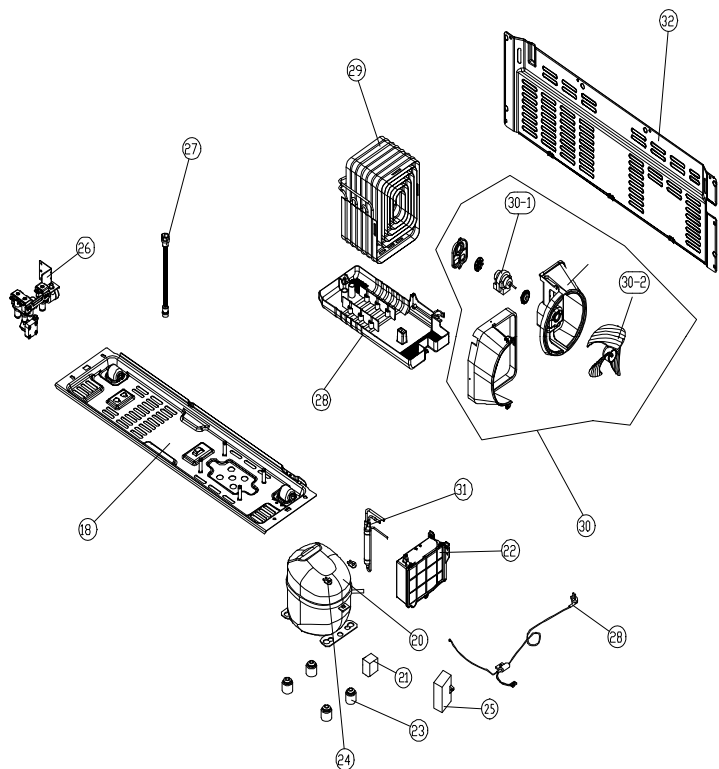

NO	PART-CODE	PART NAME	SPEC.	Q'ty		
				Basic	I & W	I & W + H/bar
18	3010359600	BASE COMP AS	-	1	1	1
19	3011346701	CORD POWER AS	CP-2PIN	1	1	1
20	3956114M80	COMPRESSOR	LQ140NAEM(220~240V/50Hz)	1	x	x
	3959115280		EU4A5Q-L2X, Inverter Comp.	x	1	1
21	3018133900	SWITCH P RELAY AS	4TM205RFB, 330M(LQ140NAEM)	1	x	x
	3018133800		4TM319SFB(EU4A5Q)	x	1	1
22	3814300300	BOX INVERTER AS	PP(EU4A5Q Only)	x	1	1
23	3010101600	ABSORBER COMP	NBR	4	4	4
24	3016002500	COMP WASHER	SK-5 T0.8	4	4	4
25	3016406100	CAPACITOR RUN	400VAC/5 μF (WIRE,P2)	1	x	x
26	3015402300	VALVE WATER AS	220~240V(X22...MODEL)	x	1	1
27	3013201700	HOSE DRN B	PE FRB-5970NB	x	1	1
28	3011199L00	CASE VAPORI AS	FRX-621B	1	1	1
29	3014467200	PIPE WICON AS	TWS OD4.76*T0.7	1	1	1
30	3018410500	MOUTHBELL AS	FRX-621B	1	1	1
30-1	3015920900	MOTER C FAN	D4612AAA31	1	1	1
30-2	3011836300	FAN	PP OD3.17*D150	1	1	1
31	3019808100	DRYER AS	C1220T-M OD19.05*L135	1	1	1
32	3001436500	COVER MACH RM AS		1	1	1

- Some parts can be chaged for improving their performance without notice.

No	Date	Note

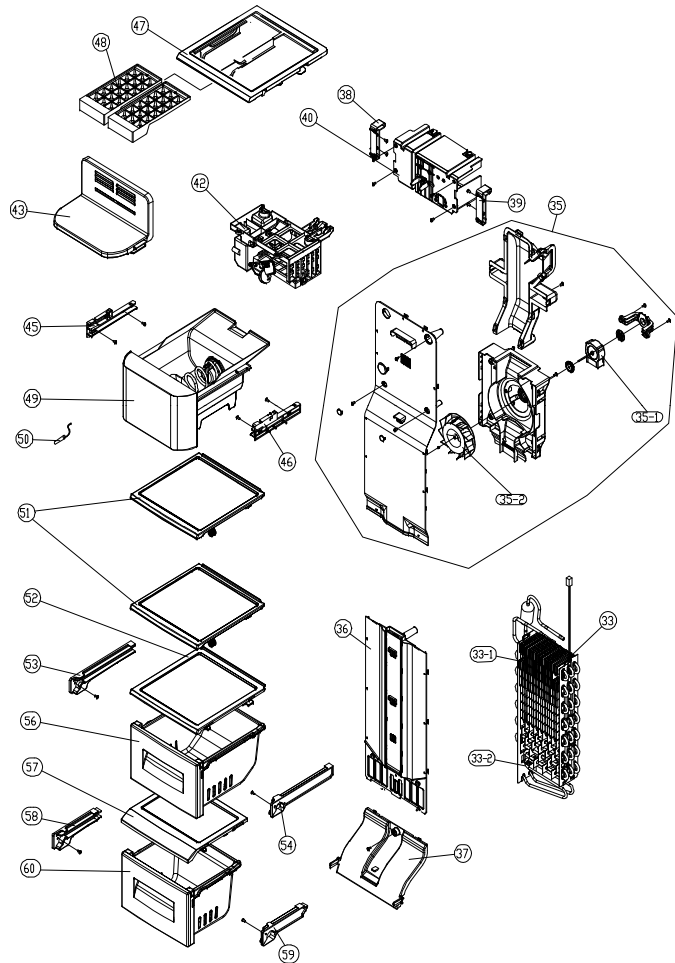

NO	PART-CODE	PART NAME	SPEC.	Q'ty		
				Basic	I & W	I & W + H/bar
33	3017068900	EVA AS	220-240V, 280W	1	1	1
33-1	3014809500	SENSOR D AS	PBN-43	1	1	1
33-2	3012824210	HEATER SHEATH AS	220-240V, 280W	1	1	x
35	3018928600	LOUVER F A AS	FRY-621B	1	1	1
35-1	3015920700	MOTOR F FAN AS		1	1	x
35-2	3011836400	FAN F		1	1	1
36	3018928900	LOUVER F B AS	FRY-621B	1	1	1
37	3001434700	COVER F RETURN	HIPS	1	1	4
38	3012517800	GUIDE G MOTR BRKT*L	ABS	x	1	1
39	3012517900	GUIDE G MOTR BRKT*R	ABS		1	1
40	3010673600	BRACKET GEARED MOTR AS	FRX-601D, 220-240V		1	1
42	3012231400	FRAME I/MAKER AS	FRX-601D		1	1
43	3001435000	COVER I/CRUSHER*T	HIPS		1	1
45	3012538200	GUIDE I/CRUSHER *L	ABS		1	1
46	3012538100	GUIDE I/CRUSHER *R	ABS		1	1
47	3017851700	SHELF F ICE AS	FRX-621B	1	x	x
48	3011186300	CASE ICING	PP	2	x	x
49	3011199K00	CASE I/CRUSHER AS	FRX-601D	x	1	1
50	3014809300	SENSOR F AS	PT-38	1	1	1
51	3017851200	SHELF F AS		2	2	4
52	3001438000	COVER F CASE*T AS		1	1	4
53	3012514512	GUIDE CASE A *L AS	FR-S580EG(PP)	1	1	x
54	3012514612	GIDUE CASE A *R AS	FR-S580EG(PP)	1	1	1
56	3011124000	CASE F*T AS		1	1	1
57	3001434500	COVER F CASE *U	HIPS	1	1	1
58	3012529712	GUIDE CASE C *L AS	FRU-5711(PP)	1	1	1
59	3012529812	GUIDE CASE C *R AS	FRU-5711(PP)	1	1	1
60	3011124100	CASE F*U AS	FRX-621B	1	1	1

- Some parts can be chaged for improving their performace without notice.

No	Date	Note

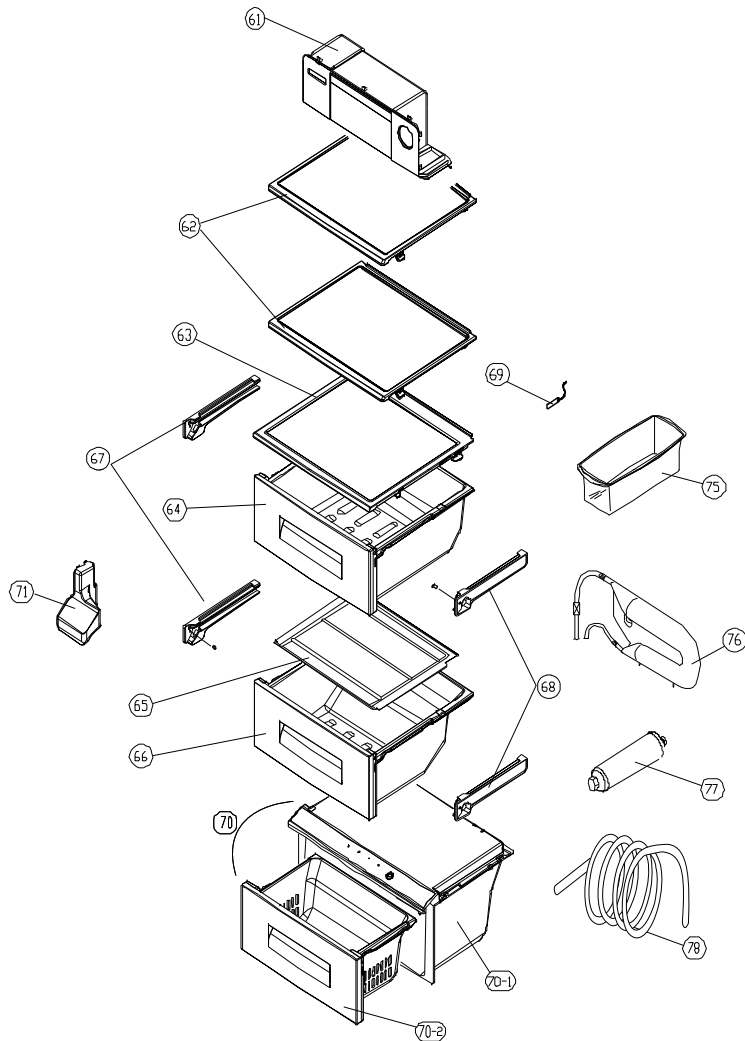

NO	PART-CODE	PART NAME	SPEC.	Q'ty		
				Basic	I & W	I & W + M/C Zone
61	3001436900	COVER DAMPER AS	FRX-621B..	1	1	1
62	3017851300	SHELF R AS	FRX-621B..	2	2	2
63	3001437200	COVER VEGETB CASE AS	FRX-621B..	2	2	1
64	3011199N00	CASE VEGETB* T AS	.	x	x	1
65	3011446600	COVER V/CASE A	GPPS	x	x	1
66	3011199P00	CASE VEGETB* M AS	FRX-621B..	1	1	1
67	3012514512	GUIDE CASE A *L AS	FR-S580EG(PP)	1	1	2
68	3012514612	GIDUE CASE A *R AS	FR-S580EG(PP)	1	1	2
69	3014809400	SENSOR R AS	PBN-43B	1	1	1
70	3010573700	BOX CHANGE RM AS	FRX-601G..	x	x	1
70-1	3001438100	COVER CHANGE RM AS	FRX-621B..	1	1	x
	3001437001		FRX-601G..	x	x	1
70-2	3011124200	CASE VEGETB *U AS	FRX-621B..	1	1	x
	3011199M00	CASE CHANGE RM AS	FRX-601G..	x	x	1
71	3001434700	COVER F RETURN	HIPS	1	1	1
75	3011171310	CASE EGG AS	CASE+VINYL	1	1	1
76	3018201000	TANK WATER AS	FRU-541D	x	1	1
77	3019974800	S/PART FILT WATER AS	FRX-601D..	x	1	1
78	3019974020	S/PART W/TUBE AS	FRX-601D..	x	1	1

- Some parts can be chaged for improving their performace without notice.

No	Date	Note

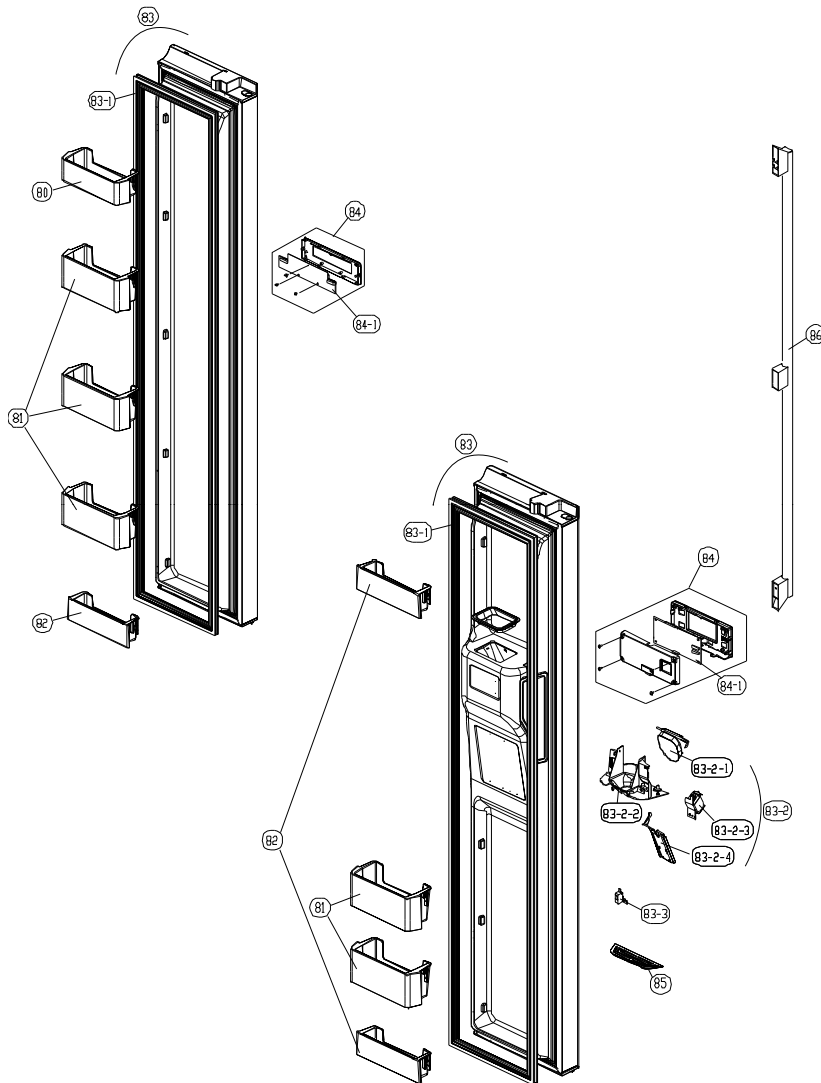

NO	PART-CODE	PART NAME	SPEC.	Q'ty	
				Basic	I & W
80	3019058000	POCKET F*T	GPPS	1	x
81	3019057900	POCKET F*M	GPPS	3	2
82	3019058100	POCKET F*U	GPPS	1	2
83	30100A7H00	ASSY F DR	FRX-62PB, TSH5L	1	x
	30100A7H10		FRX-62PB, MWH4L		
	30100A7H40		FRX-62PB, SUG7E		
	30100B7240		FRX-60PD, TSH5L	x	1
	30100B7250		FRX-60PD, MWH4L		
	30100B7280		FRX-60PD, SUG7E		
83-1	3012318860	GASKET F DR AS	FRX-621B	1	1
83-2	3010574300	BOX DISPNS I/SHUT AS	220-240V/50Hz	x	1
83-2-1	3001436601	COVER I/FLAP AS	FRX-601D	x	1
83-2-2	3010573300	BOX DISPNS I/SHUT	ABS	x	1
83-2-3	3015403000	VALVE SOL DISPNS	220-240V/50Hz	x	1
83-2-4	3013703100	LEVER DISPNS BOX AS	FRX-601D	x	1
84	3001433620	COVER F PCB AS	FRX-621B..	1	x
	3014247000	PANEL *F CONTL AS	FRX-601G..	x	1
84-1	30143HJ170	PCB FRONT AS	FRX-621B..	1	x
	30143HJ160		FRX-601G..	x	1
85	3012407800	GRILLE DISPS	ABS	x	1
86	3012652110	HANDLE AS	FRX-60PF	1	1

- Some parts can be chaged for improving their performance without notice.

No	Date	Note

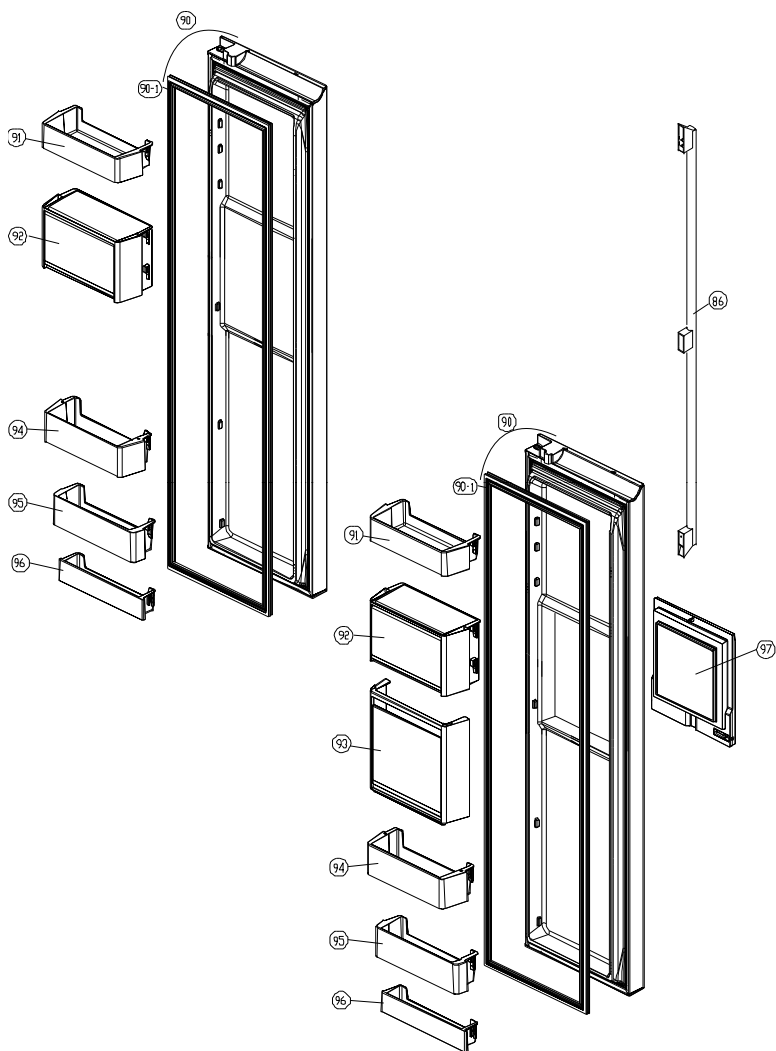

NO	PART-CODE	PART NAME	SPEC.	Q'ty	
				Basic	With H/Bar
86	3012652110	HANDLE AS	FRX-60PF	1	1
90	30100B7740	ASSY R DR	FRX-62PB, TSH5L	1	x
	30100B7750		FRX-62PB, MWH4L		
	30100B7780		FRX-62PB, SUG7E		
	30100B7330		FRX-60PF, TSH5L	x	1
	30100B7340		FRX-60PF, MWH4L		
	30100B7370		FRX-60PF, SUG7E		
90-1	3012318960	GASKET R DR AS	PVC+MAGNET	1	1
91	3019058420	POCKET R*T	GPPS	1	1
92	3019058800	POCKET MULTI AS	FRX-621B	1	1
93	3011199J00	CASE H/BAR	FRX-601G	x	1
94	3019058600	POCKET R H/BAR	GPPS	1	1
95	3019058300	POCKET R*M	GPPS	1	1
96	3010058500	POCKET R*U	GPPS	1	1
97	3001707720 3001707730	DOOR H/BAR AS	SILVER	x	1
			WHITE		

- Some parts can be chaged for improving their performance without notice.

No	Date	Note