

© ELECTROLUX ITALY S.p.A.
Spares Operations Europe
Corso Lino Zanussi, 30
I - 33080 PORCIA /PN (ITALY)

Fax +39 0434 394096

Edition: 06-2010

Publication
number

599 73 10 96

EN

Washing machines

**guide to diagnostics for
electronic controls**

EWM0931x

Contents

1	INTRODUCTION.....	5
1.1	Purpose of this manual.....	5
1.2	Warnings.....	5
1.3	How to proceed.....	5
2	WM APPLIANCE CONTROL PANELS.....	6
3	DIAGNOSTIC SYSTEM.....	7
3.1	Accessing diagnostic.....	7
3.2	Quitting the diagnostics system.....	7
3.3	Diagnostic test phases.....	8
3.4	Selector efficiency check.....	9
3.4.1	Programme selector.....	9
3.4.2	Temperature selector.....	10
4	ALARMS.....	11
4.1	Displaying the alarms to the user.....	11
4.1.1	Styling TC4-Z3.....	11
4.1.2	Styling TC5 TC6-Z5 Z6 - S6.....	11
4.2	Reading the alarms.....	12
4.2.1	Displaying the alarm.....	13
4.2.2	Example of alarm display.....	13
4.2.3	Operation of alarms during the diagnostic cycle.....	13
4.2.4	Rapid reading of alarms.....	14
4.2.5	Deleting the last alarms.....	14
4.3	ALARM SUMMARY TABLE.....	15
4.4	Notes on the behaviour of certain alarms.....	18
5	CANNOT ACCESS THE DIAGNOSTICS PROGRAMME.....	19
5.1	None of the LEDs on the circuit board light up.....	19
5.2	Some of the LEDs on the circuit board light up.....	19
6	TROUBLESHOOTING BASED ON ALARM CODES.....	20
	E11: Water fill difficulty during washing.....	20
	E13: Water leaks.....	22
	E21: Drain difficulty.....	24
	E23: Problems with the component (triac) controlling the drain pump.....	26
	E24: Sensing circuit of the component (triac) controlling the drain pump faulty.....	28
	E32: The analogue pressure switch causes an error during calibration.....	29
	E35: Water level too high.....	30
	E38: Internal pressure chamber is clogged.....	31
	E41: Door open (device with 3 connections).....	32
	E42: Problems opening door (device with 3 connections).....	34
	E44: Door closed "sensing" circuit faulty.....	37
	E45: Problems with the "sensing" circuit of the component (triac) controlling the door delay system.....	37
	E51: Motor power triac short-circuited.....	38
	E52: No signal from motor tachometric generator (<i>first part</i>).....	39
	E52: No signal from motor tachometric generator (<i>second part</i>).....	41
	E53: Problems with the "sensing" circuit of the component (triac) powering the motor.....	43
	E54: Motor relay contacts sticking.....	44
	E62: Overheating during washing.....	45
	E66: Heating element power supply relay faulty.....	46
	E68: Washing heating element leakage.....	47
	E69: Washing heating element damaged.....	48
	E6A: Heating relay sensing faulty.....	49
	E6H: Heating element power relay faulty (incongruence between sensing and relay status).....	49
	E71: Washing NTC probe faulty.....	50
	E74: NTC probe improperly positioned.....	51
	E83: Error reading the programme selector code.....	52
	E86: Programme selector configuration error.....	52
	E91: Communication error between the display board and the main circuit board.....	53
	E92: protocol incongruence.....	54
	E93: Appliance configuration error.....	54
	E94: Incorrect configuration of washing cycle.....	54
	E97: Incongruence between control selector version and configuration data.....	54
	E9C: Display board configuration error.....	54
	EC4: AGS current sensor faulty error.....	55
	EF1: Drain hose blocked/kinked/too high; drain filter clogged/dirty.....	55

EF2: Excessive detergent dosing; drain hose kinked/blocked; drain filter dirty/clogged	55
EF3: Aqua Control device triggered.....	55
EF5: Unbalanced load, spin phases skipped.	55
EF6: Reset appliance.....	55
EH1: Mains frequency incorrect.....	56
EH2: Supply voltage too high	56
EH3: Supply voltage too low.....	56
7 OPERATING CIRCUIT DIAGRAM WM WITH AQUA CONTROL	57
7.1 Key to circuit diagram WM	58
7.2 Main circuit board connectors	59
7.3 Burns on the main circuit board EWM0931x.....	60

1 INTRODUCTION

1.1 Purpose of this manual

The purpose of this manual is to explain, simply and schematically, the steps any Technician should take when faced with the problems indicated by the various alarm codes on appliances with electronic controls in the EWM0931x series, PROMETEO version.

Depending on the appliance configuration, the alarms may be entirely or partially displayed to the user: the latter solution is usually adopted.

The diagnostics system is used by Service Technicians to:

- ◆ Read alarms
- ◆ Delete the alarm stored
- ◆ Test the appliance operation

1.2 Warnings



- **Any work on electrical appliances must only be carried out by qualified technicians.**
- **The selector on this platform is not fitted with an ON/OFF switch, You have to unplug the appliance to cut off the power supply, before accessing internal components.**
- **Unplug the appliance before accessing internal components.**
- **If the heating element needs replacing, replace it with one featuring the same characteristics (2 thermal fuses) so as not to compromise the safety of the appliance. It is strictly forbidden to remove/exchange the NTC probes from one heating element to another.**
- **Always empty the appliance of all the water before laying it on its side.**
- **Never place the appliance on its right side (electronic control system side): some of the water in the detergent dispenser could leak onto the electrical/electronic components and cause these to burn.**
- **When replacing components, please refer to the code shown in the list of spare parts relating to the appliance.**

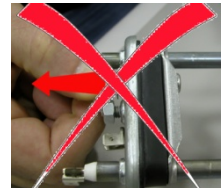

1.3 How to proceed

1. Identify the type of control in question (**page 6**) and access the diagnosis cycle (**see page 7**)
2. Read the alarm stored (**page 12**) and consult the instructions regarding the “alarm codes”, **page 15-17**.
3. Delete the alarms stored (**page 14**)
4. If you are unable to access the diagnosis mode, consult the chapter entitled “The diagnostics system cannot be accessed” (**page 19**)
5. Should the main electronic board need to be replaced, make sure there are no burns (**see page 60**)
6. After any intervention, check the appliance is operating correctly using the diagnostic cycle (**page 8**)
7. Delete any alarm that may have been stored during the diagnostics operations (**page 14**)

2 WM APPLIANCE CONTROL PANELS

These are the stylings available at the time of printing of this Service Manual. Others may be developed in future.

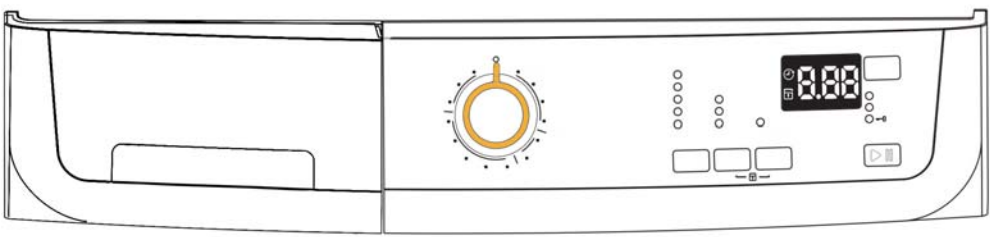
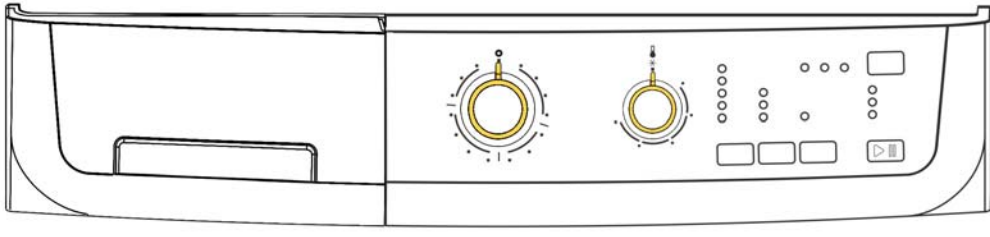
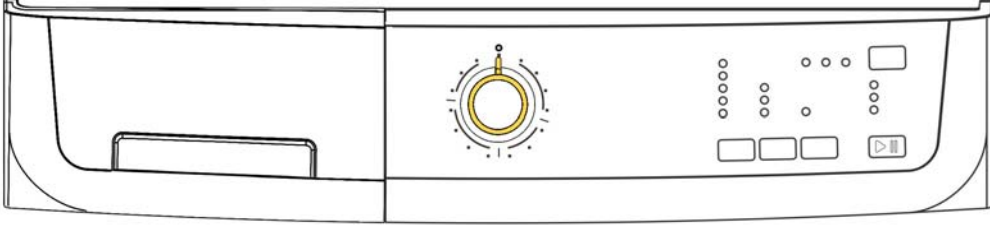
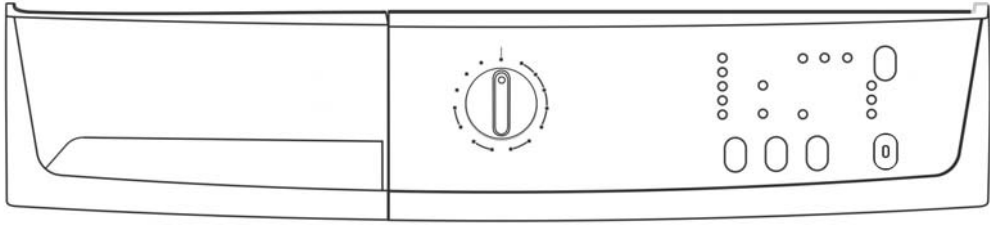
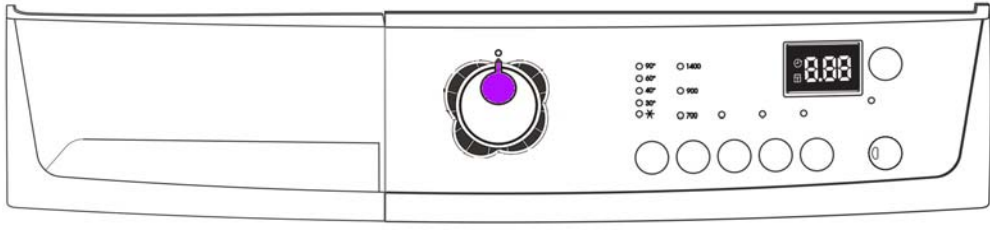
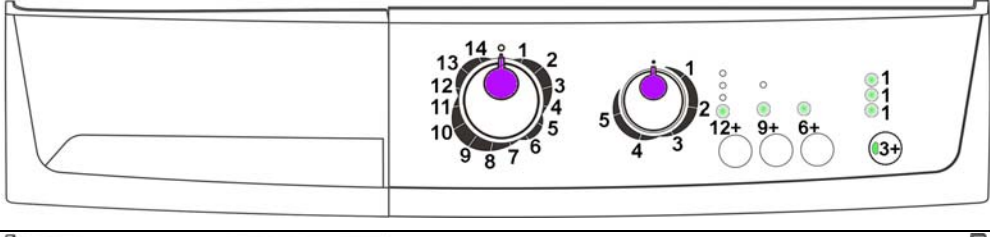
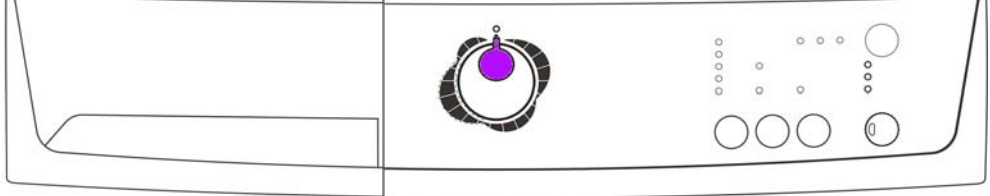
ELECTROLUX	TC4	
	TC5	
	TC6	
SIMPSON	S6	
SMART	Z3	
	Z5	
	Z6	

3 DIAGNOSTIC SYSTEM

3.1 Accessing diagnostic

All versions

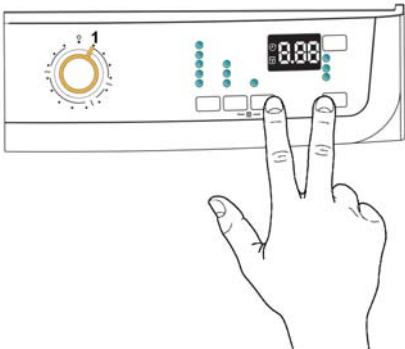
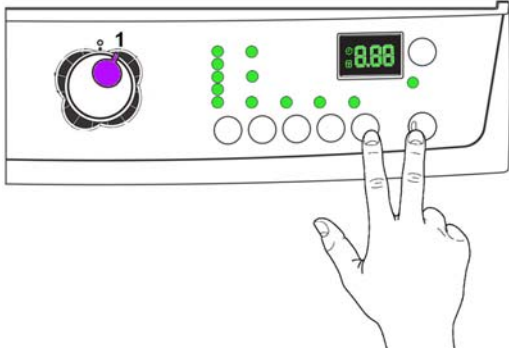
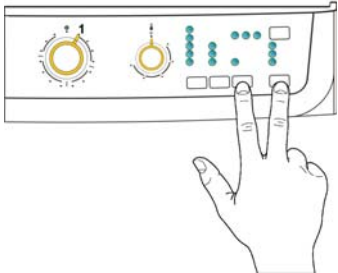
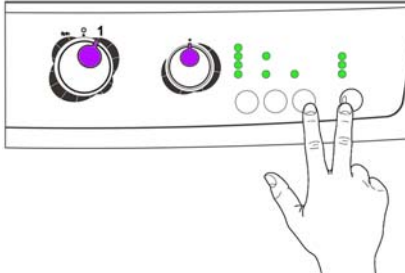
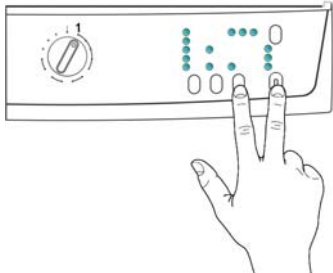
<p style="text-align: center;">TC4</p> 	<p style="text-align: center;">Z3</p> 	
<p style="text-align: center;">TC5-TC6</p> 	<p style="text-align: center;">Z5-Z6</p> 	<p style="text-align: center;">S6</p> 
<ol style="list-style-type: none"> 1. Set the selector knob to position 0 (zero). 2. Press the START/PAUSE button and the nearest option button simultaneously (as shown in the figure). 3. Holding down both buttons, switch the appliance on by turning the programme selector by one position clockwise. 4. Hold the buttons down until the LEDs start to flash (at least 2 seconds). <p>In the first position, the operation of the buttons and the related LEDs is checked; turn the programme selector knob clockwise to run the diagnostic cycle for the operation of the various components and to ready any alarms.</p>		

3.2 Quitting the diagnostics system

→ To quit the diagnostics system, turn the selector knob to position 0, turn the appliance back on and return the knob to position 0.

















3.3 Diagnostic test phases

Irrespective of the type of electrical board and of the selector configuration, once the diagnostics system has been activated, turn the selector knob **clockwise** to run a check of the various components (as described in table 1) and read the alarms.

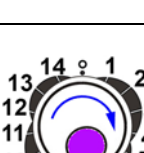
A control code for the selector (or the second selector, where applicable) is shown at the same time: in stylings TC4 and Z3 on the display for **two** seconds, before displaying what is described in the last column of the table below, whereas in stylings TC5/6, Z5/6 and S6 the code is displayed by lighting the LEDs for **three** seconds (see table 2 and 3).

All alarms are enabled in the diagnostic cycle.

TABLE 1

Selector position	Components activated	Working conditions	Function tested	Display, where featured
1 	- All the LEDs light up in sequence. - When you press a button, the corresponding group or LED lights up.	Always active	User interface functions	
2 	- Door safety interlock - Wash solenoid	Door closed Water level below anti-flooding level Maximum time 5 mins	Water fill to wash compartment	 Water level in the tub (mm)
3 	- Door safety interlock - Pre-wash solenoid	Door closed Water level below anti-flooding level Maximum time 5 mins	Water fill directly to tub	 Water level in the tub (mm)
4 	- Door safety interlock - Pre-wash and wash solenoid	Door closed Water level below anti-flooding level Maximum time 5 mins	Water fill to conditioner compartment	 Water level in the tub (mm)
6 	- Door safety interlock - Wash solenoid if the water level in the tub does not cover the heating element - Heating element	Door closed Water level above the heating element. Maximum time 10 mins or up to 90°C. (*)	Heating	 Temperature in °C measured using the NTC probe
7 	- Door safety interlock - Wash solenoid if the water level in the tub does not cover the heating element - Motor (55 rpm clockwise, 55 rpm anticlockwise, pulse at 250 rpm)	Door closed Water level above the heating element	Check for leaks from the tub	 Drum speed in rpm/10
8 	- Door safety interlock - Drain pump - Motor up to 650 rpm then at maximum spin speed (**)	Door closed Water level lower than anti-boiling level for spinning	Drain, Calibration of analogue pressure switch and spin	 Drum speed in rpm/10
9	----	----	----	
10 	- Reading/Deleting the last alarm	----	----	

(*) In most cases, this time is sufficient to check the heating. However, the time can be increased by repeating the phase without draining the water: pass for a moment to a different phase of the diagnostic cycle and then back to the heating control phase (if the temperature is higher than 80°C, heating does not take place).

(**) The check at the maximum speed occurs without control of the AGS and no garments must be inside the appliance.

3.4 Selector efficiency check

Diagnostic testing also provides the opportunity to check the efficiency of the selectors.

3.4.1 Programme selector

In the control panel illustrated below, the LEDs (lit) are combined with values.

When the knob is turned, some LEDs light up, and by summing up the values with which they are combined, you obtain the position of the knob (if the selector is efficient).

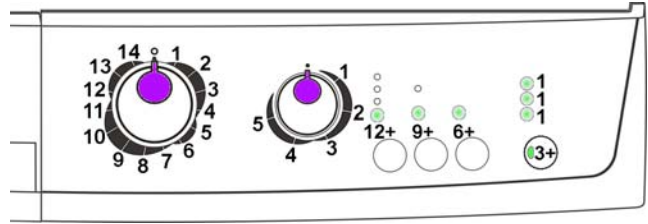

The table below includes all the possible selector control combinations:

0		1	
2		3	
4		5	
6		7	
8		9	
10		11	
12		13	
14			

3.4.2 Temperature selector

The same description as the programme selector applies to the temperature selector.

TABLE 3			
0			
1			
2			
3			
4			
5			

4 ALARMS

4.1 Displaying the alarms to the user

4.1.1 Styling TC4-Z3

The alarms are displayed by the flashing red LED of the START/PAUSE button and simultaneously through the Display.

The alarms displayed to the user are listed below:

- ↔ **E10 - Water fill difficulty (tap closed)**
- ↔ **E20 - Drain difficulty (filter dirty)**
- ↔ **E40 - Door open**

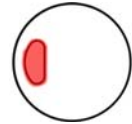

4.1.2 Styling TC5 TC6-Z5 Z6 - S6

The alarms are displayed by the flashing red LED of the START/PAUSE button and by one of the three LEDs above the START/PAUSE button.

The table below illustrates the various combinations of LED lightings.

E10		E20		E40	
Water fill difficulty (tap closed)		Drain difficulty (filter dirty)		Door open	

The aforementioned alarms (for both versions) can be remedied directly by the end user.

On the other hand, the alarms listed below (for both versions):

- ↔ **EF0 – Water leakage (Aqua Control System)**
- ↔ **EH0 – Voltage or frequency outside the normal values**

are displayed to the user, but technical assistance is required to remedy them.

The alarms are enabled during the execution of the washing programme. With the exception of alarms associated with the configuration and the power supply voltage/frequency, which are also displayed during the programme selection phase.

The door can normally be opened (except where specified) when an alarm condition has occurred, on the condition that:

- The level of the water in the tub is below a certain level.
- The water temperature is lower than 55°C.
- The motor has stopped.

Certain alarm conditions require that a drain phase be performed before the door can be opened for safety reasons:

- Cooling water fill if the temperature is higher than 65°C.
- Drain until the analogue pressure switch is on empty, during a max. 3-minute time.

4.2 Reading the alarms

The last three alarms stored in the FLASH memory of the PCB can be displayed:

- Enter the diagnostic mode.
- Irrespective of the type of PCB and configuration, turn the programme selector knob **clockwise** to the **tenth position**.
- The last alarm is displayed.
- To display the previous alarms, press the button to the left of the START/PAUSE button in sequence (as shown in the figure).

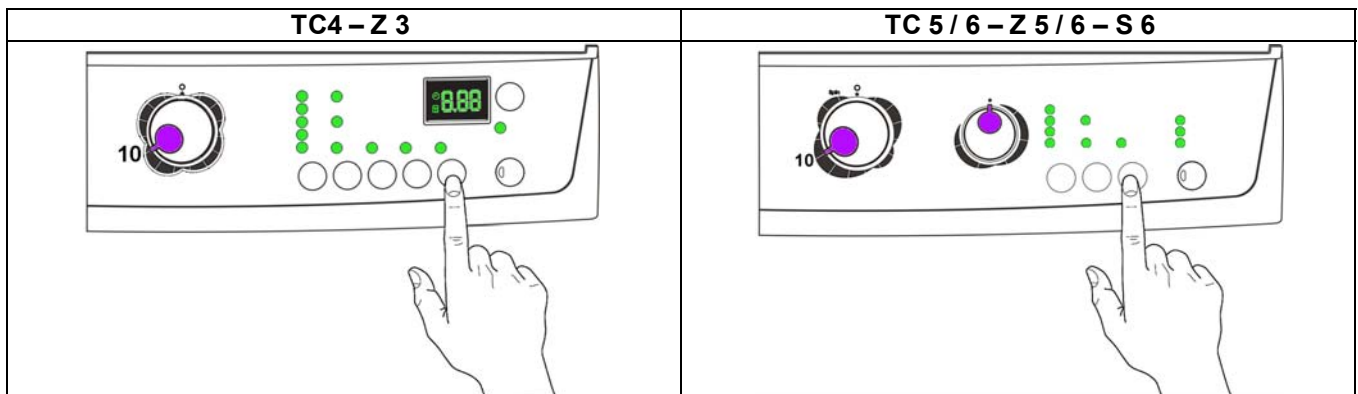
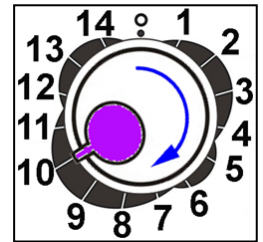

- To return to the last alarm, press the START/PAUSE button

4.2.1 Displaying the alarm

The alarm is displayed by a repeated flashing sequence of the START/PAUSE button with red and green light (0.5 seconds on, 0.5 seconds off with a 2.5 second pause between the sequences).

- START/PAUSE button indicator with red light → indicates the first digit of the alarm code (family)
- START/PAUSE button indicator with green light → indicates the second digit of the alarm code (number within the family)

These two LEDs are featured in all models.

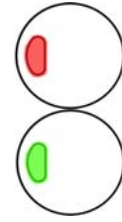

















Notes:

- The first letter of the alarm code “E” (Error) is not displayed, since this letter is common to all alarm codes.
- The alarm code families are shown in hexadecimal; in other words:
 - **A** is represented by **10** flashes
 - **B** is represented by **11** flashes
 - ...
 - **F** is represented by **15** flashes
- Configuration errors are shown by the flashing of all LEDs (user interface not configured).

4.2.2 Example of alarm display

For example, in the case of alarm E43 (problem with the door safety TRIAC) ; the following will be displayed:

- the sequence of four flashes of the START/PAUSE button with the red light indicates the first number **E43**;
- the sequence of three flashes of the START/PAUSE button with the green light indicates the second number **E43**;

START/PAUSE button with red light			START/PAUSE button with green light		
ON/OFF	Time (Sec.)	Value	ON/OFF	Time (Sec.)	Value
	0.5	1		0.5	1
	0.5			0.5	
	0.5	2		0.5	2
	0.5			0.5	
	0.5	3		0.5	3
	0.5			0.5	
	0.5	4		2.5	Pause
	0.5				
	1.5	Pause			

4.2.3 Operation of alarms during the diagnostic cycle

All alarms are enabled during the components diagnostic cycle.

4.2.4 Rapid reading of alarms

The last alarm can be displayed even if the programme selector is not in the tenth position (diagnostics) or if the appliance is in normal operating mode (e.g. during the execution of the washing programme):

- Press the **START/PAUSE** button and the nearest **option button** simultaneously (as if you were entering DIAGNOSTIC mode) for at least 2 seconds: the LEDs initially switch off, and then display the flashing sequence indicating the last alarm.
- The alarm continues to be displayed for the amount of time required, and then the display returns to its normal operation.
- The alarm reading system is as described in para. 4.2
- While the alarm is being displayed, the appliance continues to perform the cycle or, if in the programme selection phase, it maintains the previously selected options in memory.

4.2.5 Deleting the last alarms

Before deleting any alarms, make a note of the last alarm on the “Service Order” form.

- Delete them after reading them, to check whether the alarms re-occur during the diagnostic cycle.
- Delete them after repairing the appliance, to check whether they re-occur during testing.

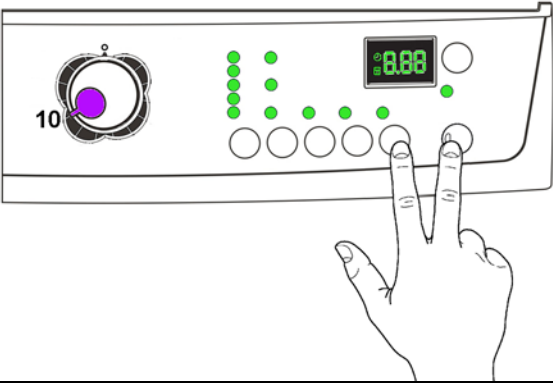
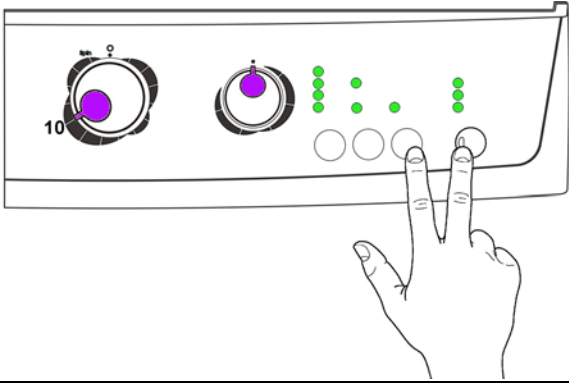
TC 4 – Z 3	TC 5 / 6 – Z 5 / 6 – S 6
	
<ol style="list-style-type: none"> 1. Select diagnostic mode, turn the programme selector to the tenth position (reading of alarms) 2. Press the START/PAUSE button and the nearest option button simultaneously (as shown in the figure). 3. Hold down the buttons until the LEDs stop flashing and the LCD display shows “E00” (at least 5 seconds). 	<ol style="list-style-type: none"> 1. Select diagnostic mode, turn the programme selector to the tenth position (reading of alarms) 2. Press the START/PAUSE button and the nearest option button simultaneously (as shown in the figure). 3. Hold the buttons down until the LEDs stop flashing (at least 5 seconds).

N.B. This operation will also delete all the stored alarms.

4.3 ALARM SUMMARY TABLE

Alarm	Description	Possible fault	Machine status/action	Reset	Page
E00		No alarm		-----	-----
E11	Water fill difficulty during washing	Tap closed or water pressure too low; Drain hose improperly positioned; Water fill solenoid valve faulty; Leaks from water circuit on pressure switch; Pressure switch faulty; Wiring faulty; Main PCB faulty.	Cycle is paused with door locked	START/RESET	20
E13	Water leaks	Drain hose improperly positioned; Water pressure too low; Water fill solenoid valve faulty; Water circuit on pressure switch is leaking/clogged; Pressure switch faulty.	Cycle is paused with door locked	START/RESET	22
E21	Drain difficulty during washing	Drain hose kinked/clogged/improperly positioned; Drain filter clogged/dirty; Wiring faulty; Drain pump faulty; Pressure switch faulty; Main PCB faulty.	Cycle paused (after 2 attempts)	START/RESET	24
E23	Faulty triac for drain pump	Wiring faulty; Drain pump faulty; Main PCB faulty.	Safety drain cycle - Cycle stops with door open	RESET	26
E24	Malfunction in sensing circuit on triac for drain pump (wrong input voltage to micro-processor)	Main circuit board faulty.	Safety drain cycle - Cycle stops with door unlocked	RESET	28
E31	Malfunction in electronic pressure switch circuit (frequency of signal from pressure switch outside limits)	Wiring; Electronic pressure switch; Main PCB;	Cycle stops with door locked	RESET	28
E32	Calibration error of the electronic pressure switch (The electronic pressure switch generates a signal with unstable frequency during the drain phase)	Drain hose kinked/clogged/improperly positioned; Solenoid valve faulty; Drain filter clogged/dirty; Drain pump faulty; pressure chamber; Leaks from water circuit on pressure switch; pressure switch; Wiring; main PCB;	Cycle paused	START/RESET	29
E35	Overflow	Water fill solenoid valve faulty; Leaks from water circuit on pressure switch; Wiring faulty; Pressure switch faulty; Main PCB faulty.	Cycle interrupted. Safety drain cycle. Drain pump continues to operate (5 min. on, then 5 min. off. etc.)	RESET	30
E38	Internal pressure chamber is clogged (water level does not change for at least 30 sec. of drum rotation)	Motor belt broken; Water circuit on pressure switch clogged.	Heating phase is skipped	ON/OFF RESET	31
E41	Door open (after 20 sec.)	Check whether the door is closed properly; Wiring faulty; Door safety interlock faulty; Main circuit board faulty.	Cycle paused	START/RESET	32
E42	Problems with door lock Door still locked after 4' 25".	Wiring faulty; Door safety interlock faulty; Electrical current leak between heating element and earth; Main PCB faulty.	Cycle paused	START/RESET	36
E43	Faulty triac supplying power to door delay system	Wiring faulty; Door safety interlock faulty; Main circuit board faulty.	(Safety drain cycle) Cycle blocked	RESET	40

Alarm	Description	Possible fault	Machine status/action	Reset	Page
E44	Faulty sensing by door delay system	Main circuit board faulty.	(Safety drain cycle) Cycle blocked	RESET	42
E45	Faulty sensing by triac on door delay system (wrong input voltage to micro-processor)	Main circuit board faulty.	(Safety drain cycle) Cycle blocked	RESET	42
E51	Motor power triac short-circuited.	Current leakage from motor or from wiring; Main PCB faulty;	Cycle stops with door open (after 5 attempts)	ON/OFF	43
E52	No signal from motor tachometric generator	Wiring faulty; Motor faulty; Main circuit board faulty.	Cycle stops with door locked (after 5 attempts)	ON/OFF	44
E53	Motor triac sensing circuit faulty (wrong input voltage to micro-processor)	Main circuit board faulty.	Cycle blocked	RESET	48
E54	Motor relay contacts sticking (high voltage level when the relay switches to OFF)	Current leakage from motor or from wiring; Main PCB faulty;	Cycle blocked (after 5 attempts)	RESET	49
E62	Overheating during washing (temperature higher than 88°C for more than 5 min.)	Wiring faulty; NTC probe for wash cycle faulty; Heating element faulty; Main PCB faulty.	Safety drain cycle Cycle stops with door open	RESET	50
E66	Heating element power relay faulty (incongruence between sensing and relay status)	Main PCB faulty;	Safety water fill Cycle stops with door closed	ON/OFF RESET	51
E68	Earth-leakage (value of grid voltage different from main value)	Earth-leakage between heating element and earth.	Heating phase is skipped	START/RESET	52
E69	Heating element interrupted	Wiring faulty; Heating element for washing interrupted (thermal fuse open)	-----	START ON/OFF RESET	53
E6A	Heating relay sensing faulty	Main PCB faulty.	Cycle stops with door locked	RESET	54
E6H	Heating element power relay faulty (incongruence between sensing and relay status)	Earth-leakage between heating element and earth. Main PCB faulty.	Safety water fill Cycle stops with door closed	ON/OFF RESET	54
E71	NTC probe for wash cycle faulty (short-circuited or open)	Wiring faulty; NTC probe for wash cycle faulty; Main PCB faulty.	Heating phase is skipped	START/RESET	55
E74	NTC probe for wash cycle improperly positioned	Wiring faulty; NTC probe for wash cycle improperly positioned; NTC probe faulty; Main PCB faulty.	Heating phase is skipped	START/RESET	56
E83	Error in reading selector	Main PCB faulty (Incorrect configuration data).	Cycle cancelled	START/RESET	57
E86	Selector configuration error	Display board	-----	START ON/OFF RESET	57
E91	Communication error between main PCB and display	Wiring faulty; Control/display PCB faulty Main PCB faulty.	-----	RESET	58

Alarm	Description	Possible fault	Machine status/action	Reset	Page
E92	Communication incongruence between main PCB and display (incompatible versions)	Incorrect control/display PCB; Incorrect PCB (do not correspond to the model).	Cycle blocked	ON/OFF	59
E93	Appliance configuration error	Main PCB faulty (Incorrect configuration data);	Cycle blocked	ON/OFF	59
E94	Incorrect configuration of washing cycle	Main PCB faulty (Incorrect configuration data);	Cycle blocked	ON/OFF	59
E97	Incongruence between programme selector and cycle configuration	Main PCB faulty (Incorrect configuration data).	Cycle blocked	RESET	59
E9C	Display board configuration error	Display board	-----	START ON/OFF RESET	59
EC4	AGS current sensor faulty.	Main board faulty.	Spin speed reduced to safety speed of 150 rpm	RESET	60
EF1	Drain filter clogged (drain phase too long)	Drain filter clogged/dirty. Drain hose blocked/kinked/too high;	Warning displayed at the end of cycle	START/RESET	60
EF2	Overdosing of detergent (too much foam during drain phases)	Excessive detergent dosing; Drain hose kinked/blocked; Drain filter clogged/dirty.	Warning displayed after 5 attempts or by the specific LED	RESET	60
EF3	Aqua control system intervention	Water leaks onto base frame; Aqua control system faulty.	Appliance drains	ON/OFF RESET	60
EF5	Unbalanced load	Final spin phases skipped	-----	START/RESET	60
EF6	Reset	If it continues, replace the main board.	No action to be taken	-----	60
EH1	Supply frequency of appliance outside the limits	Problems with the power supply network (incorrect/disturbed); Main PCB faulty.	Wait for nominal frequency conditions	ON/OFF	61
EH2	Supply voltage too high	Problems with the power supply network (incorrect/disturbed); Main PCB faulty.	Wait for nominal voltage conditions	ON/OFF	61
EH3	Supply voltage too low	Problems with the power supply network (incorrect/disturbed); Main PCB faulty.	Wait for nominal voltage conditions	ON/OFF	61

4.4 Notes on the behaviour of certain alarms

- **Configuration alarm E93:** when this alarm is detected (on switching on the appliance), the appliance stops, the LEDs in the START/PAUSE button start to flash, displaying the complete code (family plus alarm), the display shows the alarm code provided the relevant configuration part is intact. It will not be possible to access diagnostics mode and the only available option is to turn the appliance off.
- **Configuration alarm E94:** the LEDs in the START/PAUSE button start to flash, displaying the complete code (family plus alarm) and the code is also shown on the display. The diagnostics mode cannot be accessed and the "quick alarm viewing" mode cannot be used.
- **Alarms EH1-EH2-EH3:** in the event of problems with the supply voltage, the appliance remains in alarm status until the mains frequency or voltage returns to acceptable values or the appliance is switched off (programme selector set to "0"). Only the family of the alarm "H" is displayed if the problem occurs during normal appliance operation. The family plus the alarm are displayed if the problem occurs when the appliance is switched on. The LEDs in the START/PAUSE button flash and the code is shown on the display at the same time. The diagnostics mode cannot be accessed and the "quick alarm viewing" mode cannot be used: the alarm can only be read in full when the situation has normalised.
- **Alarms E51- E52:** all the alarms are displayed during diagnostic testing: normally, when shifting from one control phase to another, the appliance quits the alarm mode and executes the selected phase. This is not the case for alarms E51 (motor power supply TRIAC short-circuiting) and E52 (no signal from motor tachometric generator): the only choice to quit the alarm mode is to turn the programme selector to position "0" (reset).

5 CANNOT ACCESS THE DIAGNOSTICS PROGRAMME

5.1 None of the LEDs on the circuit board light up

Are the power supply cable and the connection on the main PCB (connector J4) working properly?	No →	Replace/repair the power supply cable, check the connection
Yes ↓		
Is the communication wiring between the main board (connector J10) and the display board (connector J3) working properly? (insert and remove)	No →	Replace/repair wiring
Yes ↓		
Does the programme selector knob function mechanically?	No →	Replace/repair knob Replace display board
Yes ↓		
Change the main circuit board Is the appliance working correctly?	No →	Replace display board
Yes ↓		
Run the diagnostics programme.		

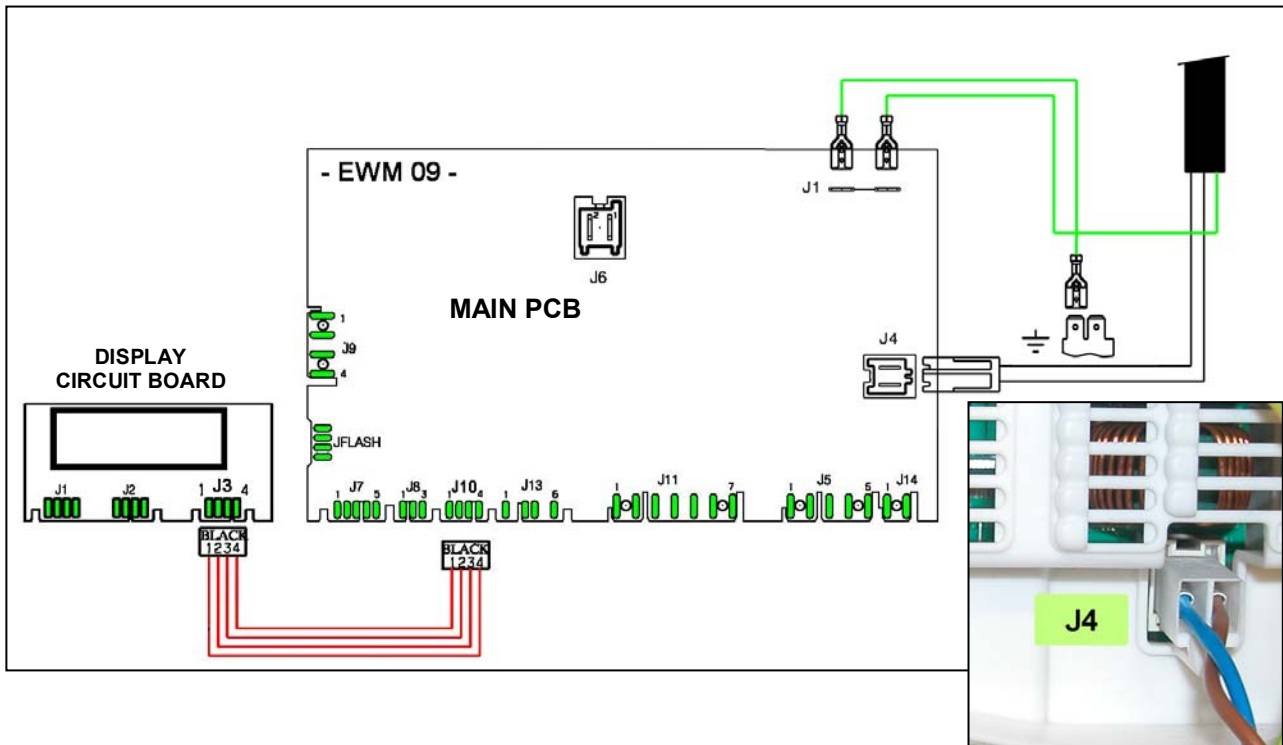

5.2 Some of the LEDs on the circuit board light up

Are the keys unobstructed through the control panel slots and do they activate the various buttons correctly?	No →	Sort out any mechanical problems (control panel/buttons/pins)
Yes ↓		
Change the circuit board and run the diagnostics programme		

6 TROUBLESHOOTING BASED ON ALARM CODES

E11	E11: Water fill difficulty during washing	E11
	Maximum water fill time for every level of the pressure switch (the time is reset every time the level is achieved)	

Checks to perform: Check that all the connectors are inserted correctly

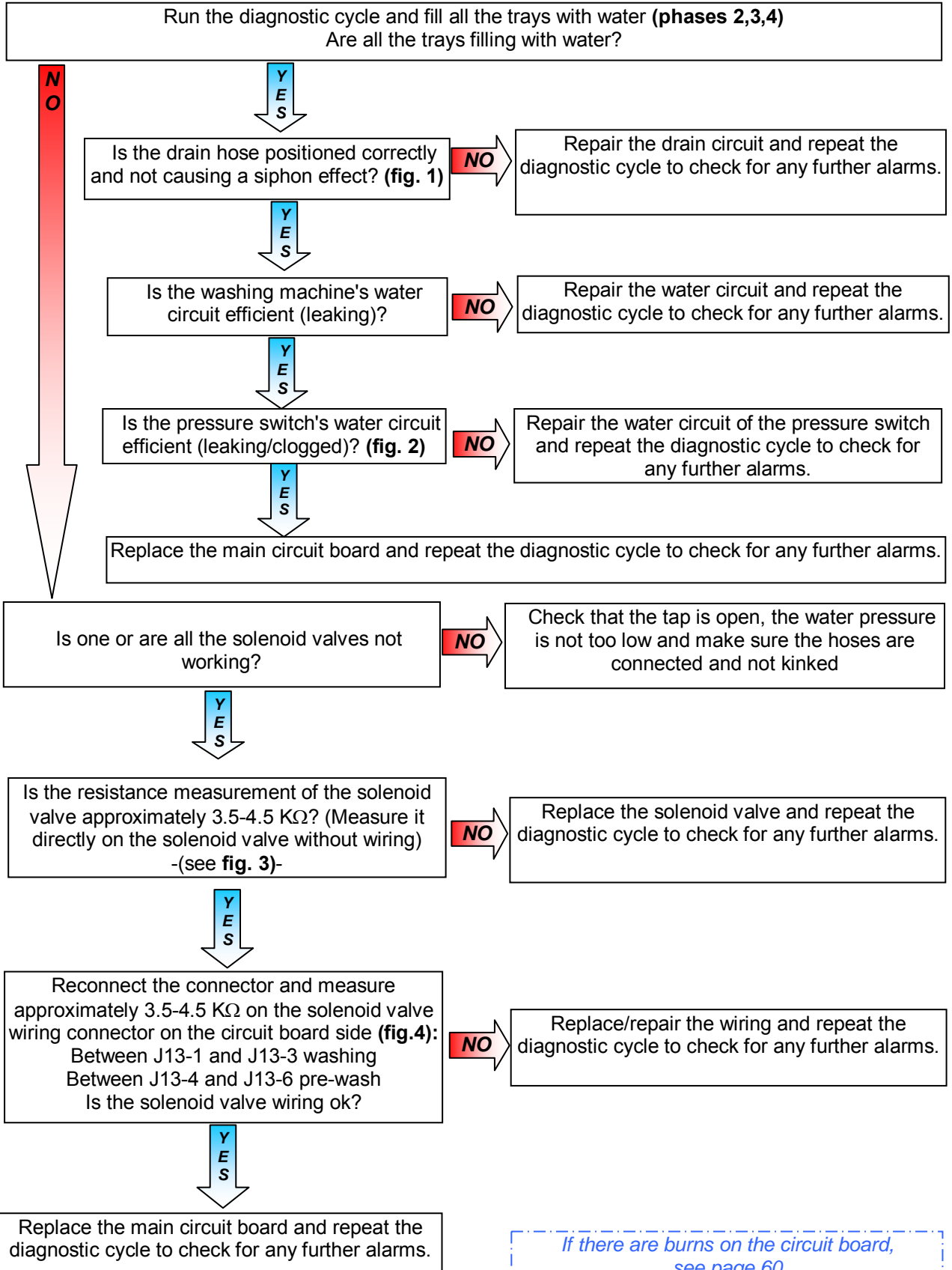

E11

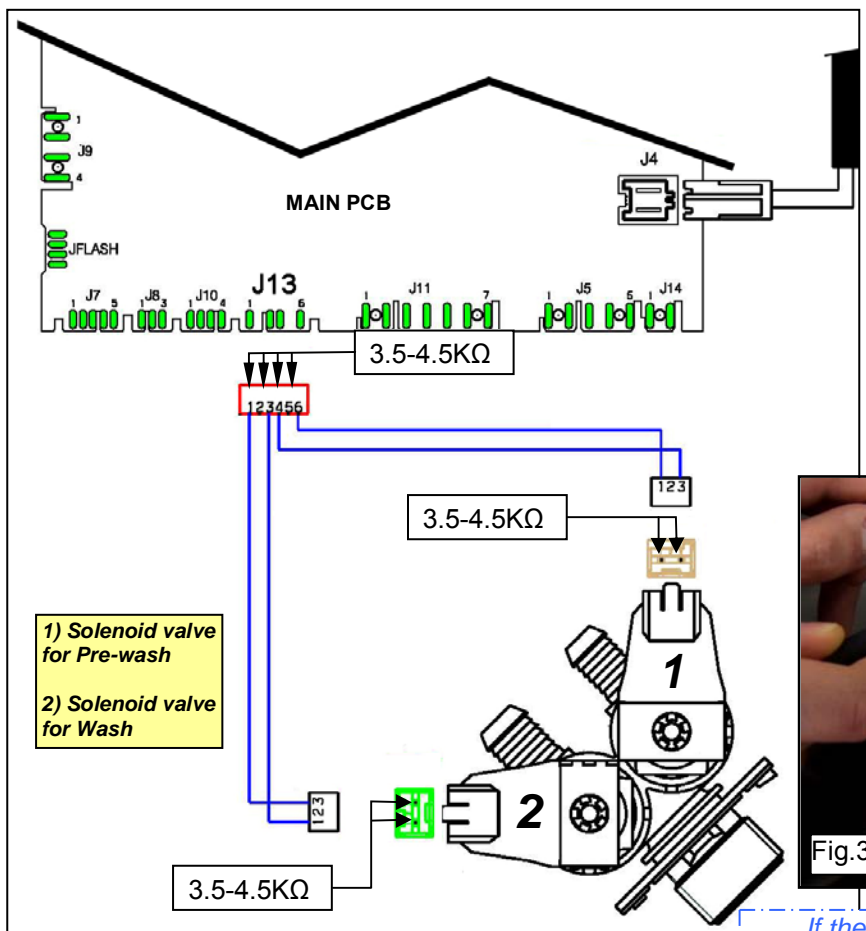
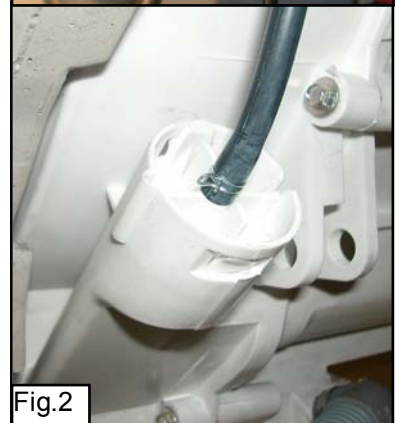
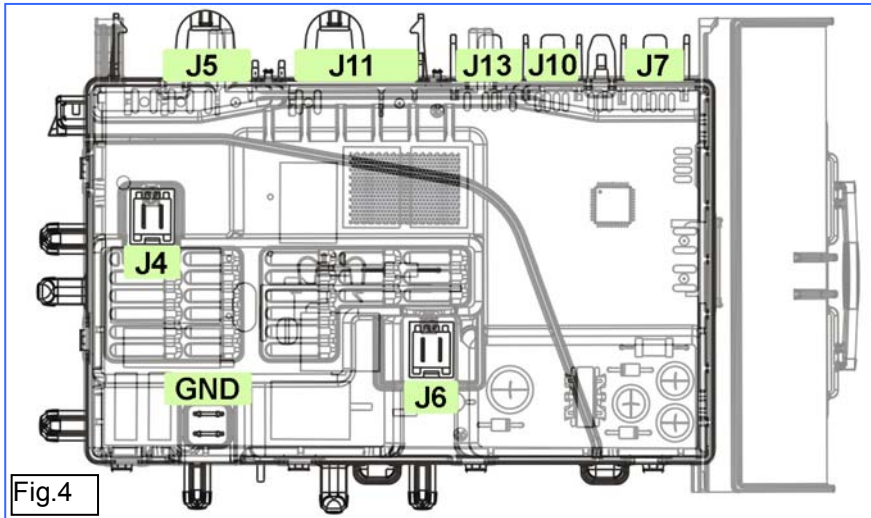
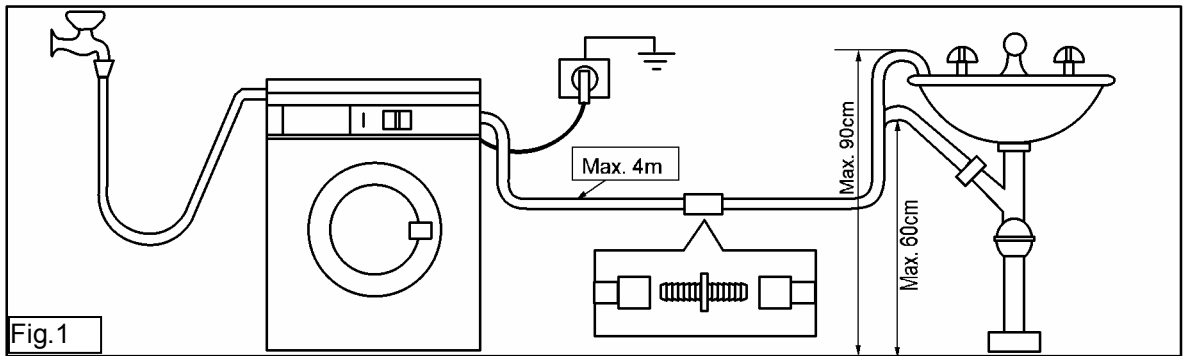

If there are burns on the circuit board, see page 60

E13	E13: Water leaks Maximum overall water fill time exceeded (sum of all water fills between one drain phase and the next to avoid exceeding the maximum volume)	E13
------------	---	------------

Checks to perform: *Check that all the connectors are inserted correctly*

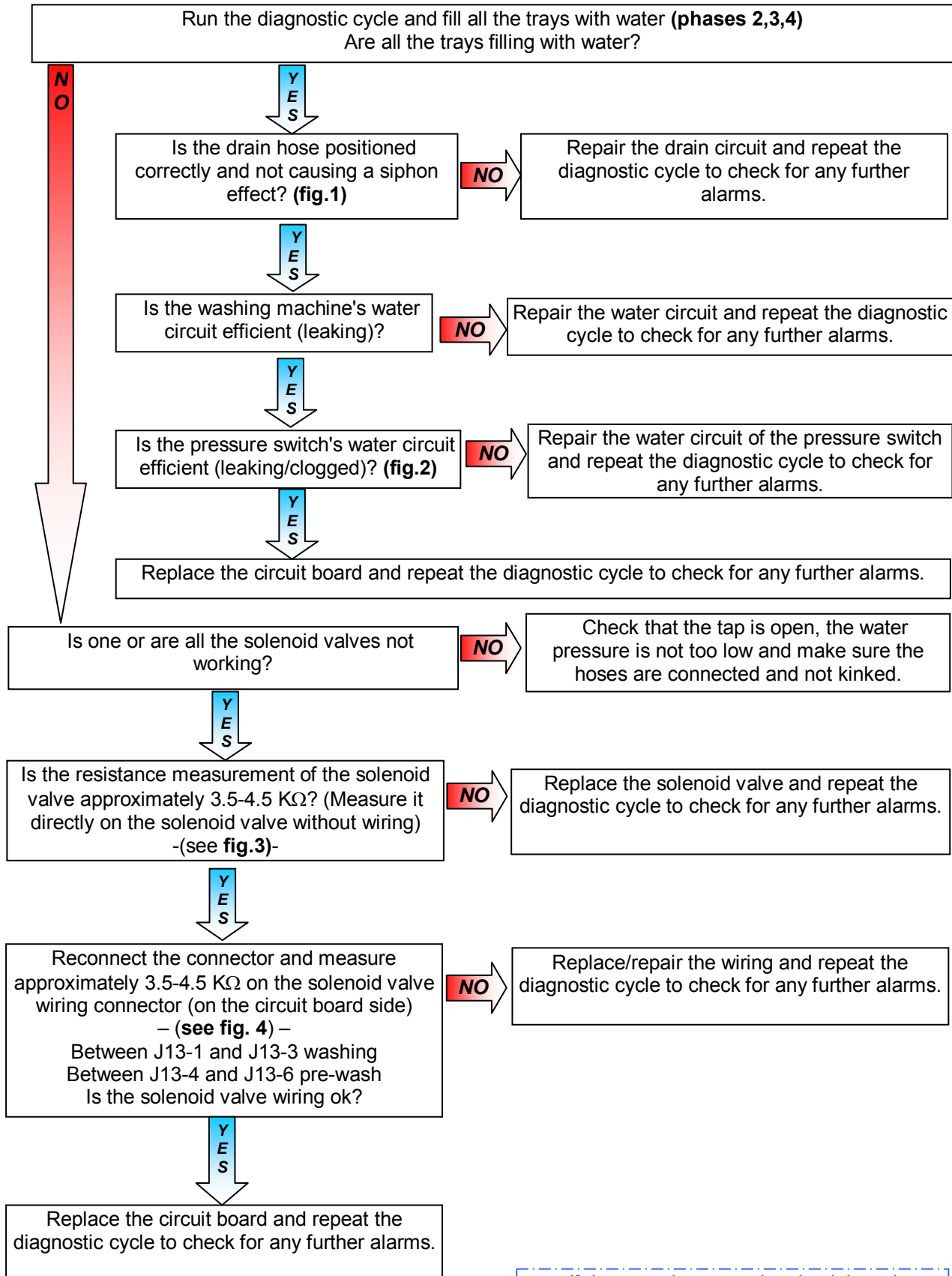

If there are burns on the circuit board, see page 60

E13

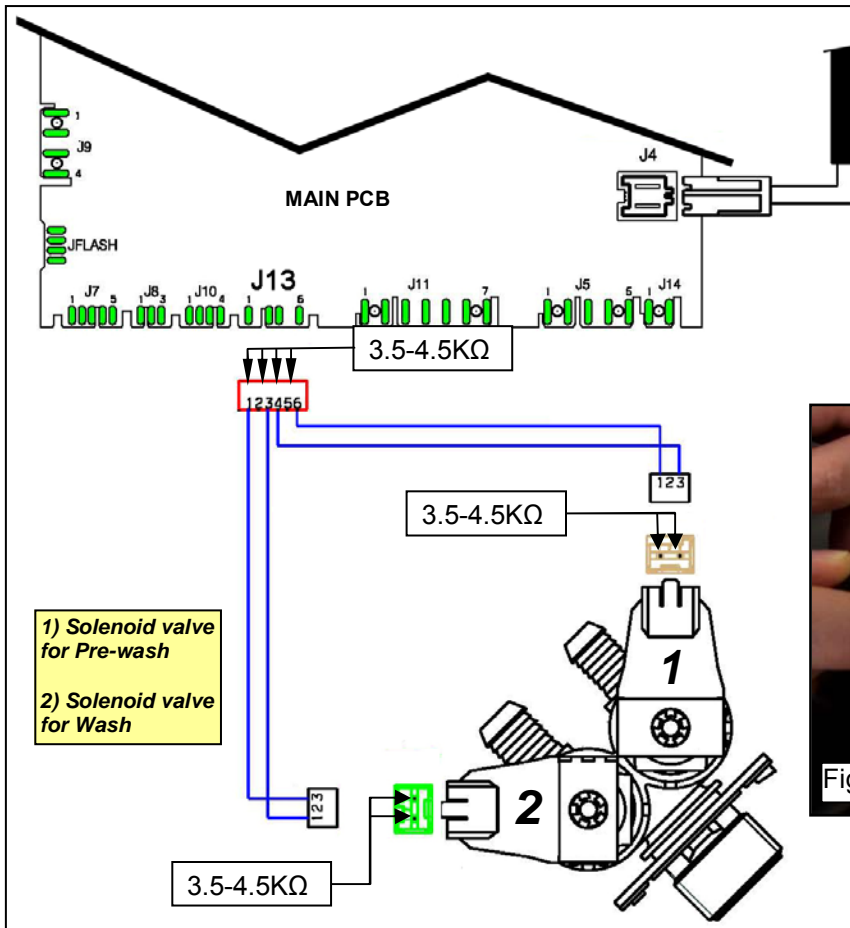
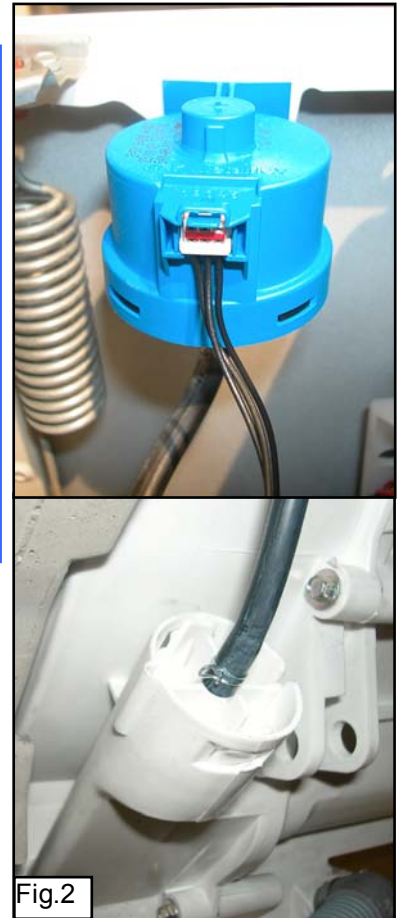
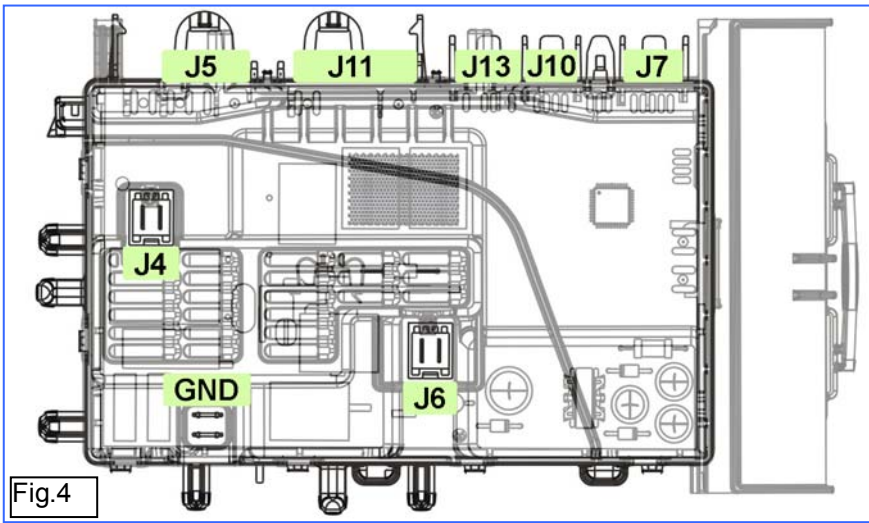
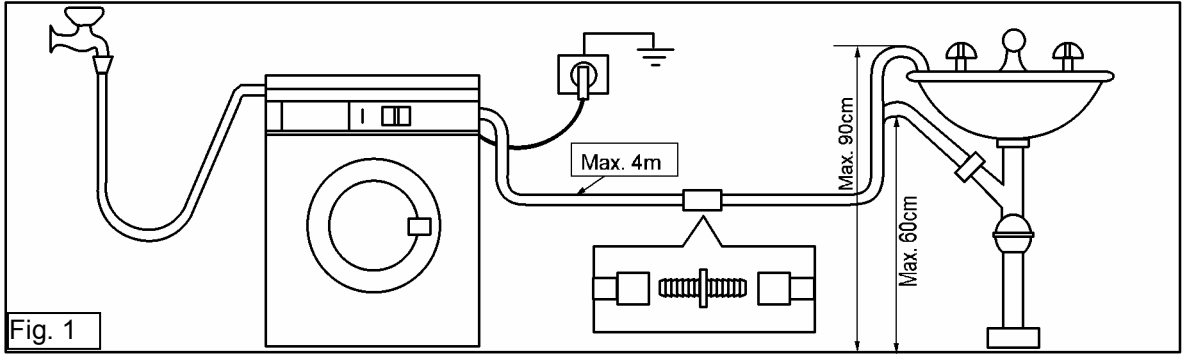

If there are burns on the circuit board, see page 60

E21	E21: Drain difficulty	E21
	Maximum drain time exceeded (measured for every cycle phase)	

Checks to perform: Check that all the connectors are inserted correctly

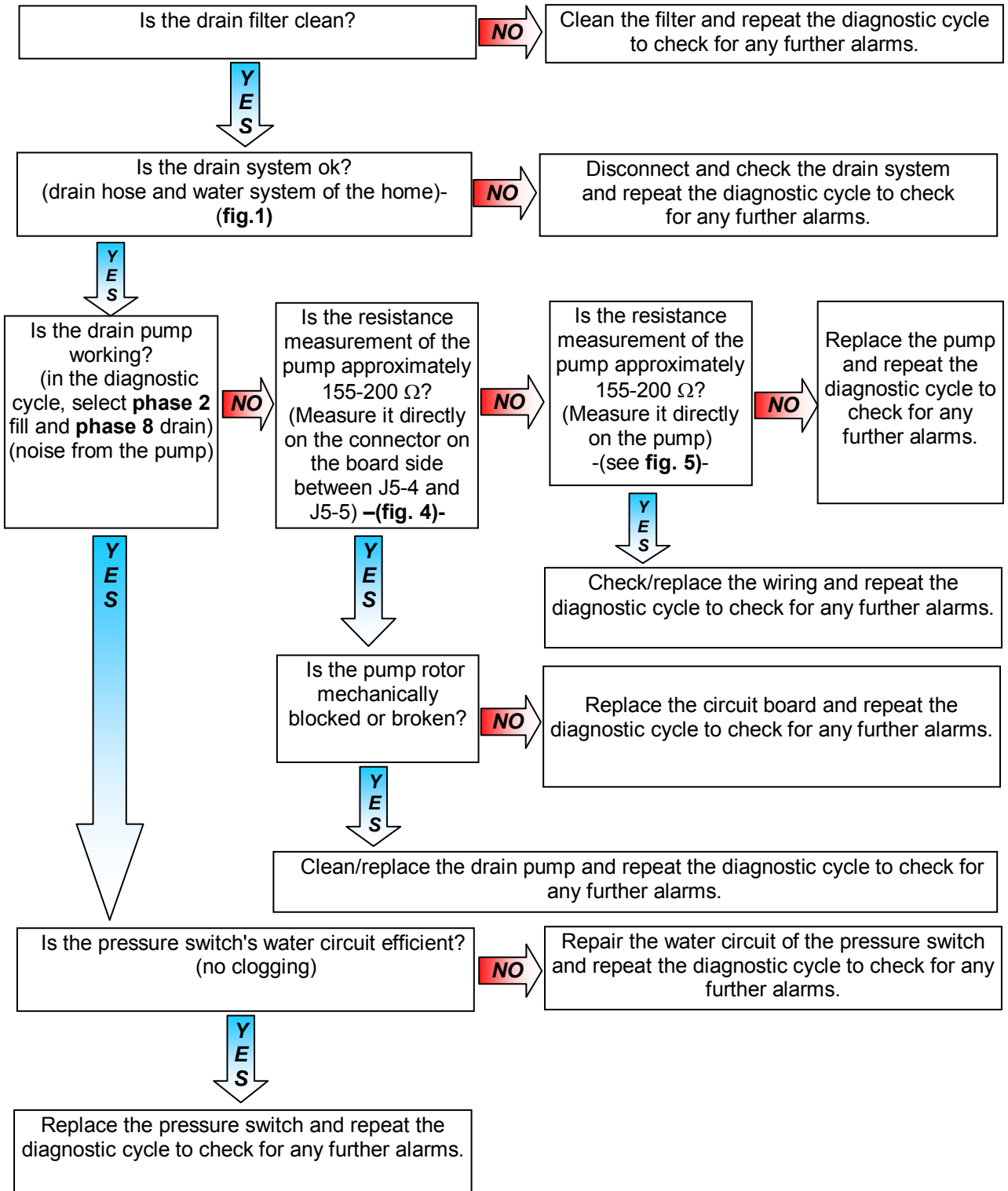

If there are burns on the circuit board, see page 60

E21

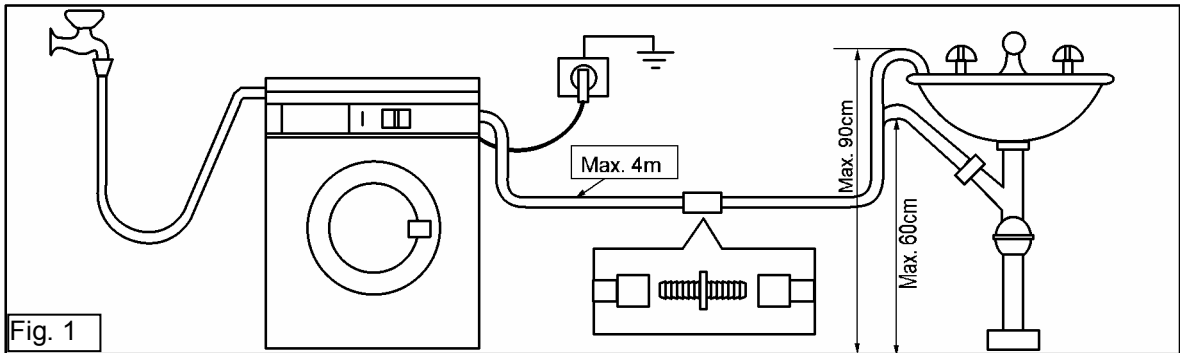

Fig. 1

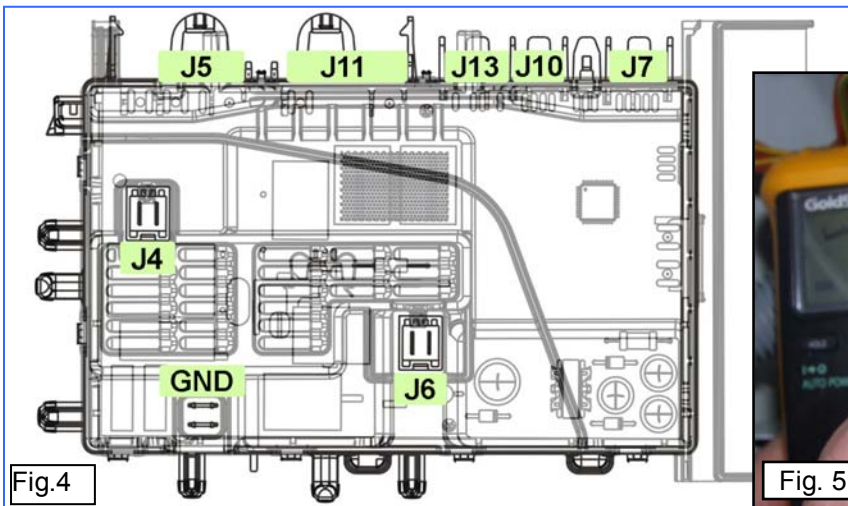

Fig. 4

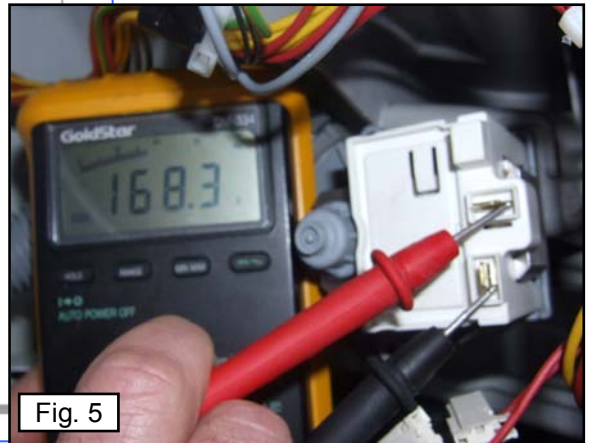
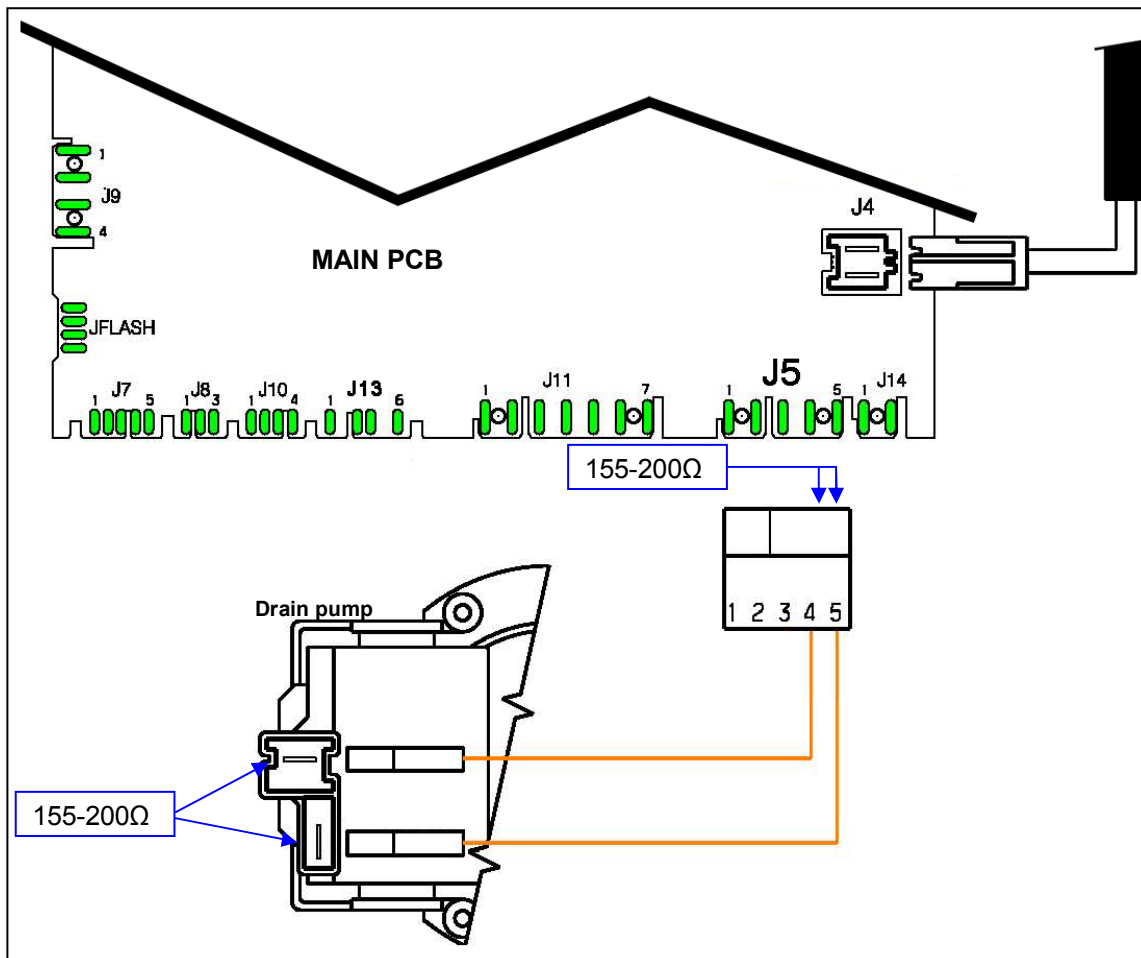

Fig. 5



If there are burns on the circuit board, see page 60

E23

E23: Problems with the component (triac) controlling the drain pump

E23

Checks to perform: Check that all the connectors are inserted correctly

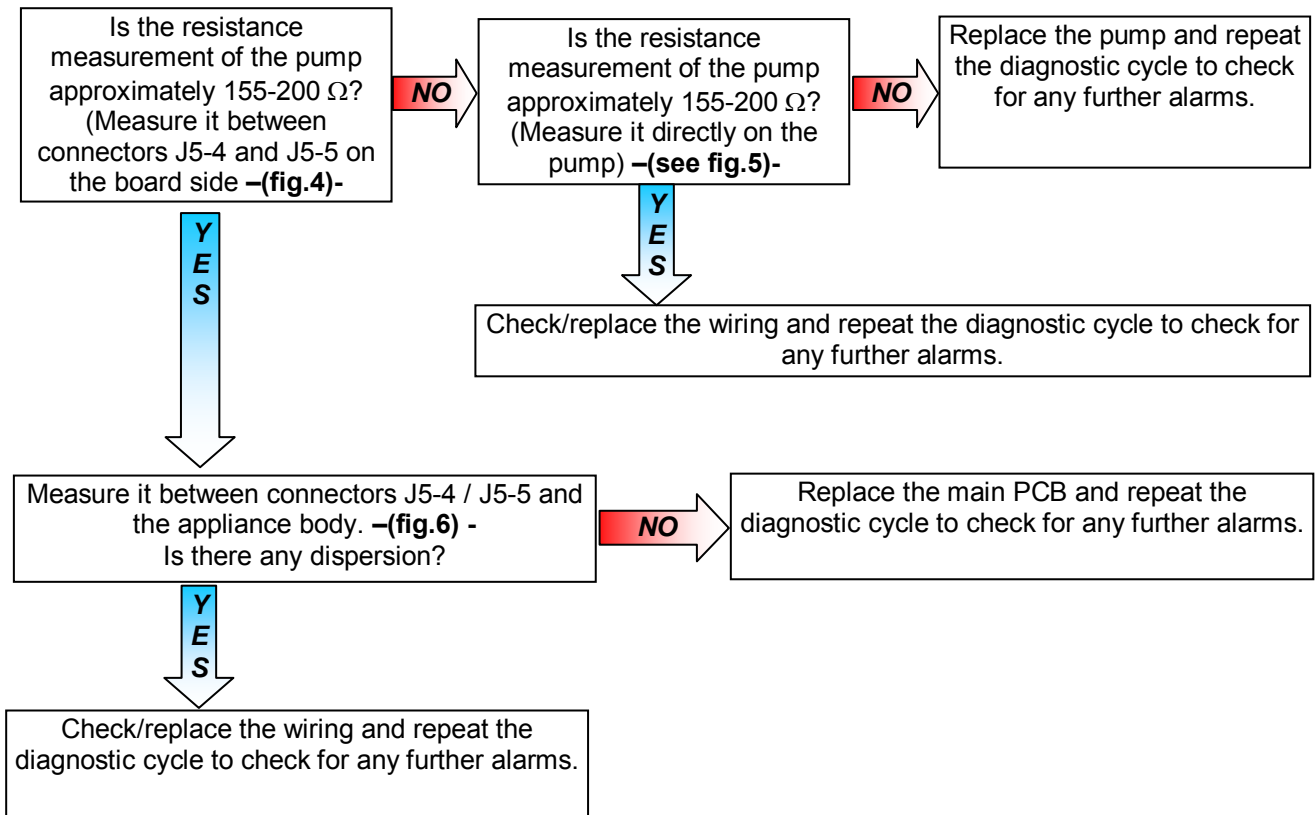

If there are burns on the circuit board, see page 60

E23

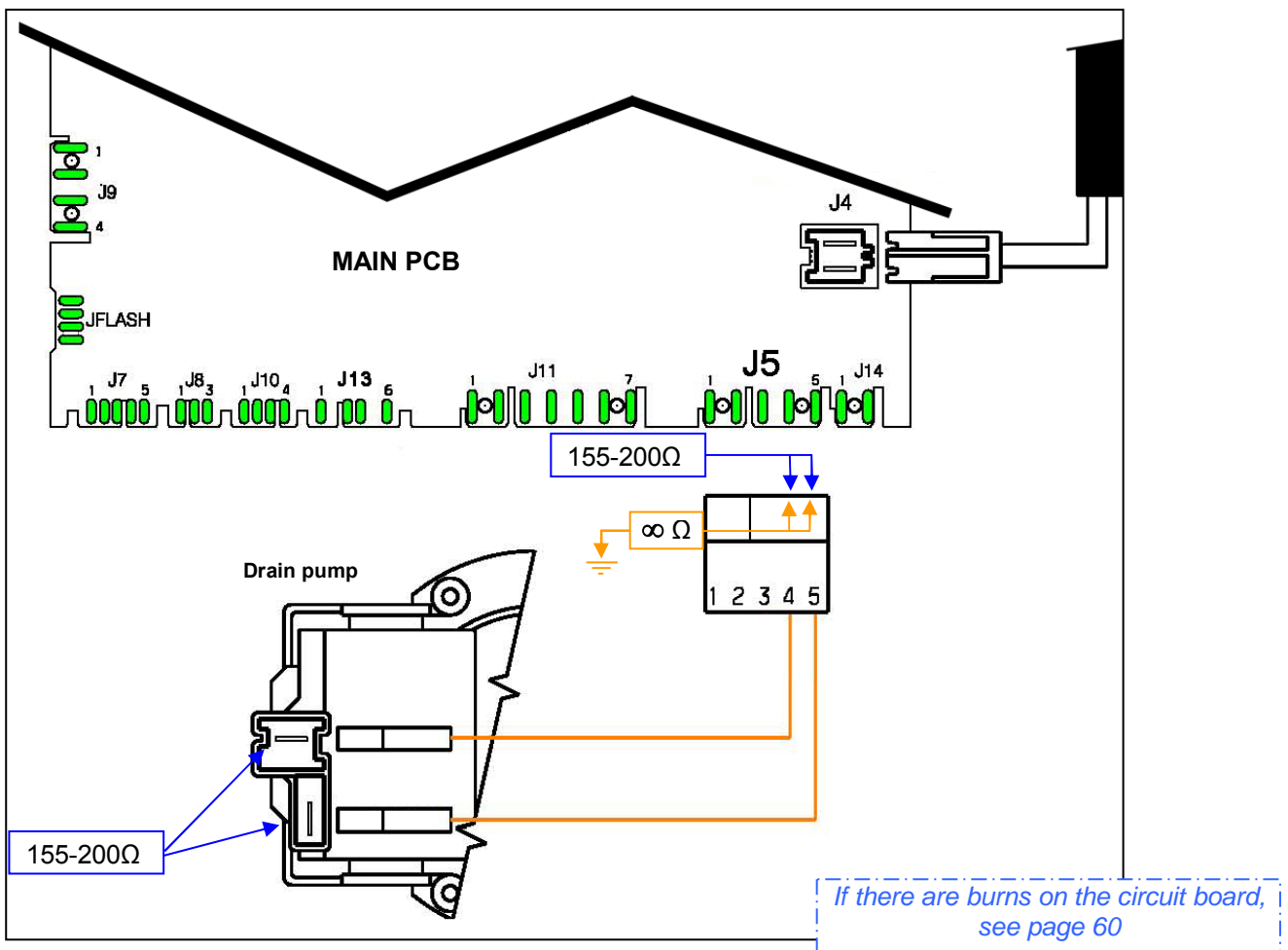
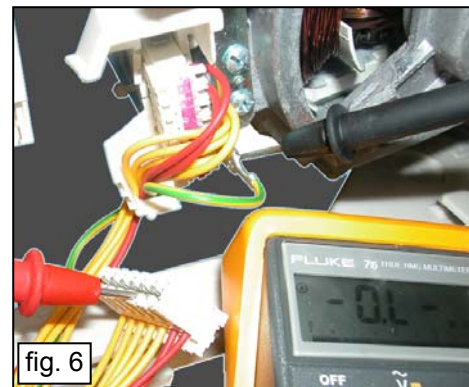
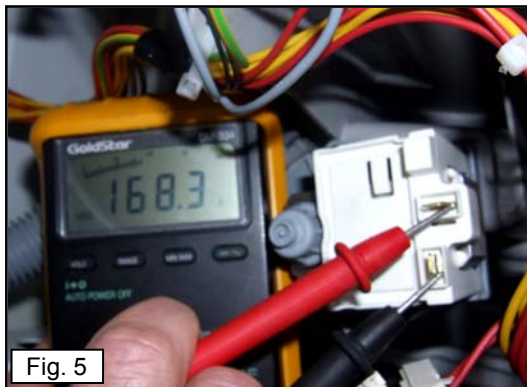
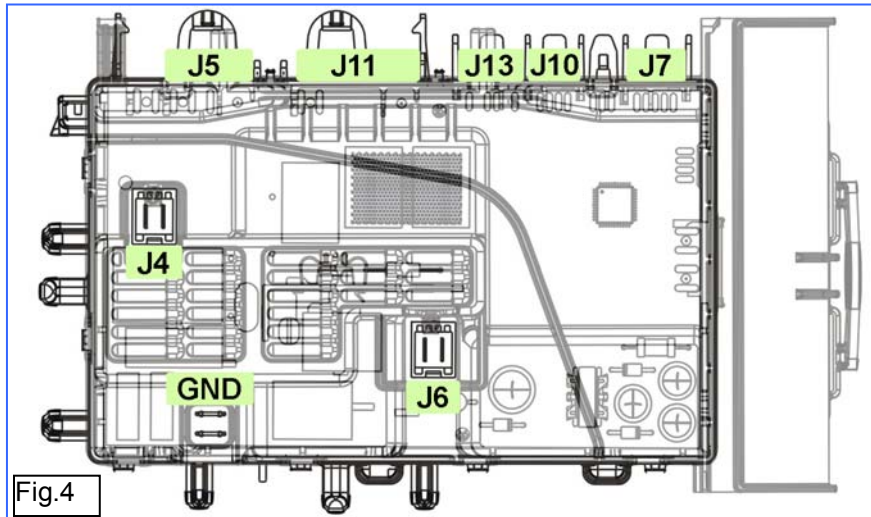

E24	E24: Sensing circuit of the component (triac) controlling the drain pump faulty	E24
------------	--	------------

Checks to perform: Check that all the connectors are inserted correctly

Replace the circuit board and repeat the diagnostic cycle to check for any further alarms.

If there are burns on the circuit board, see page 60

E31	E31: The analogue pressure switch provides the main PCB with a signal outside the limits	E31
------------	---	------------

Checks to perform: Check that all the connectors are inserted correctly

Measure that the circuit is closed between J7-1, J7-2, J7-3 and the connector of the analogue pressure switch (they are three independent wires (see fig. 7).
Is the wiring between the main circuit board and the analogue pressure switch ok and is it connected correctly on both sides?

NO →

Reconnect and/or replace the wiring and repeat the diagnostic cycle to check for any further alarms.

YES
↓

Replace the analogue pressure switch and repeat the diagnostic cycle to check for any further alarm codes.
Is the appliance displaying the alarm code again?

YES
↓

Replace the main circuit board and repeat the diagnostic cycle to check for any further alarm codes.

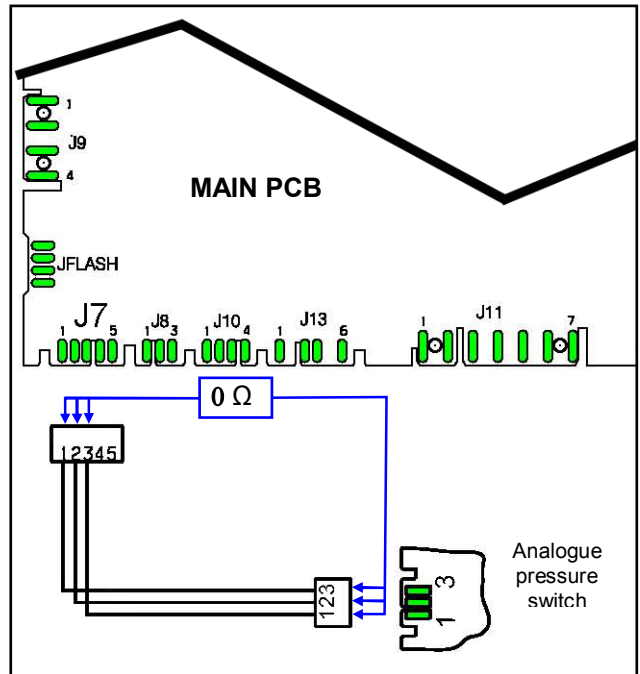

If there are burns on the circuit board, see page 60

E32	E32: The analogue pressure switch causes an error during calibration (At the start of every cycle, the appliance drains to empty the tub and creates a level 0 to check the calibration of the analogue pressure switch)	E32
------------	--	------------

Checks to perform: Check that all the connectors are inserted correctly

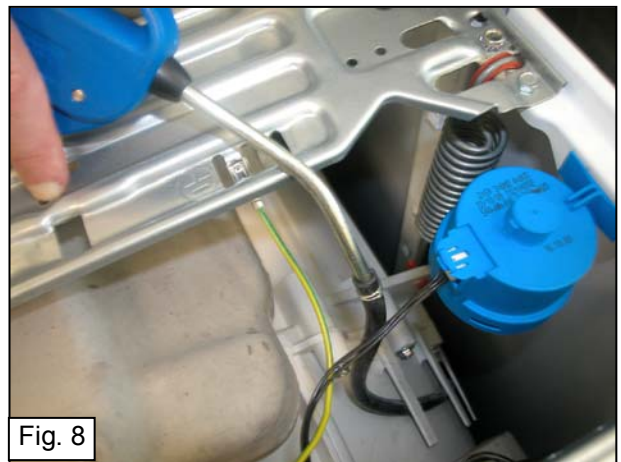
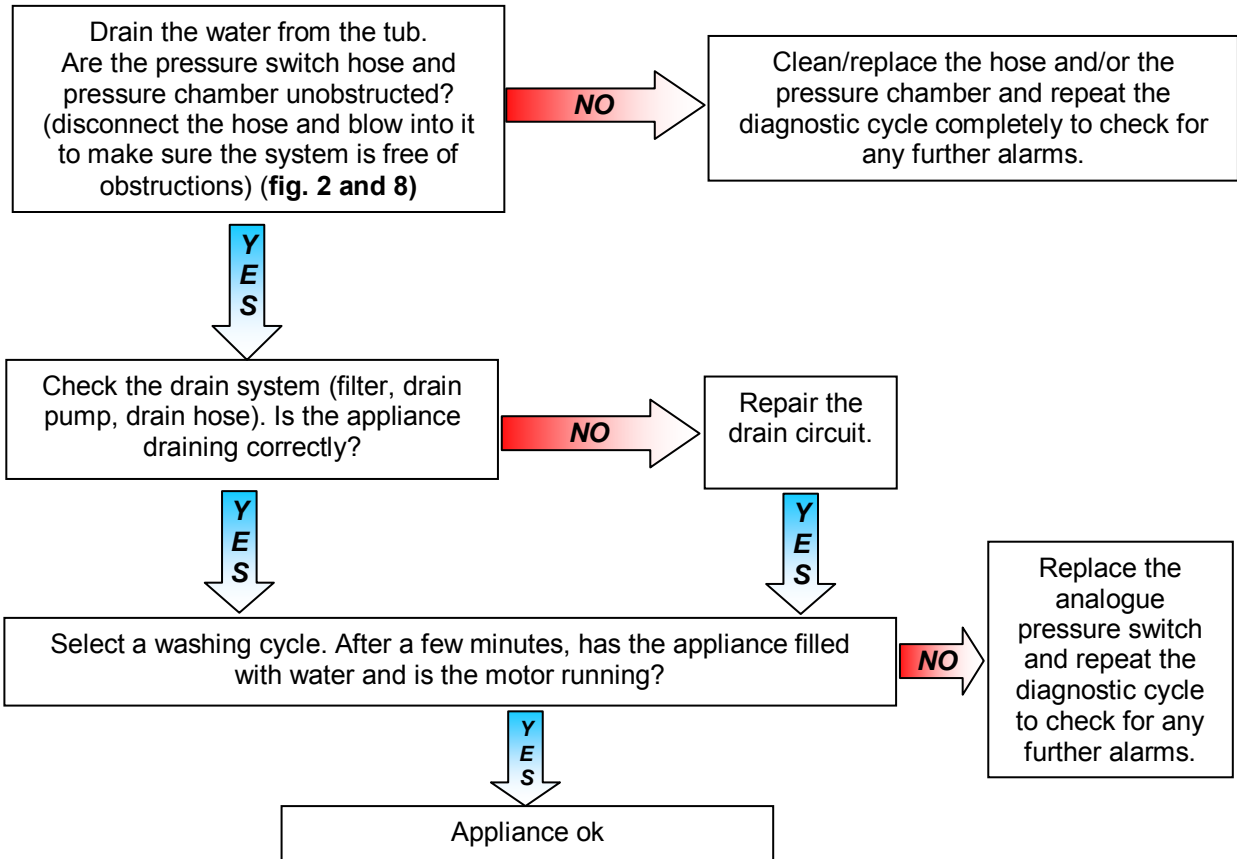

If there are burns on the circuit board, see page 60

E35	E35: Water level too high	E35
	The main circuit board measures a water level, using the electronic pressure switch, of more than 300 mm for longer than 15 secs.	

Checks to perform: Check that all the connectors are inserted correctly

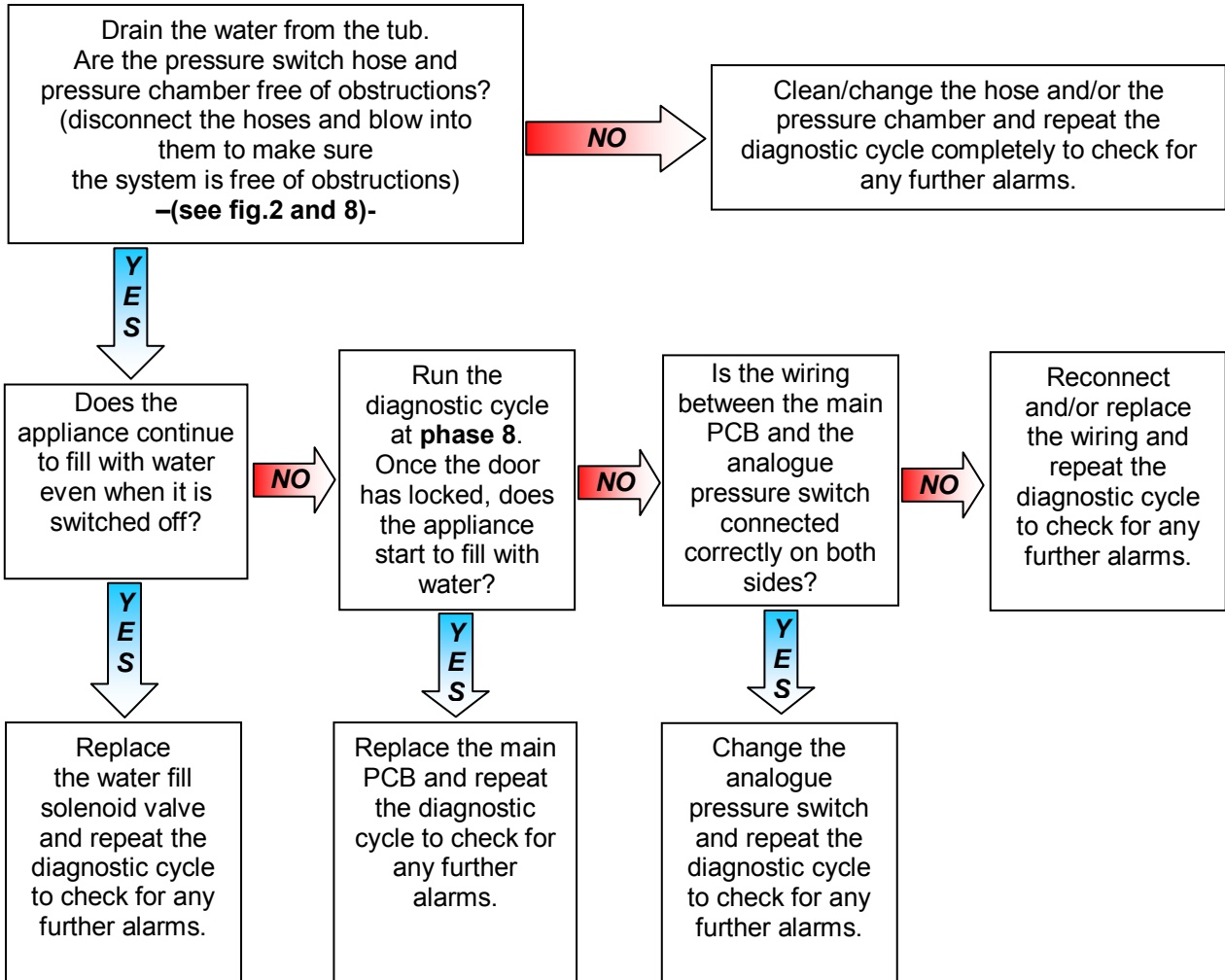

Fig.2

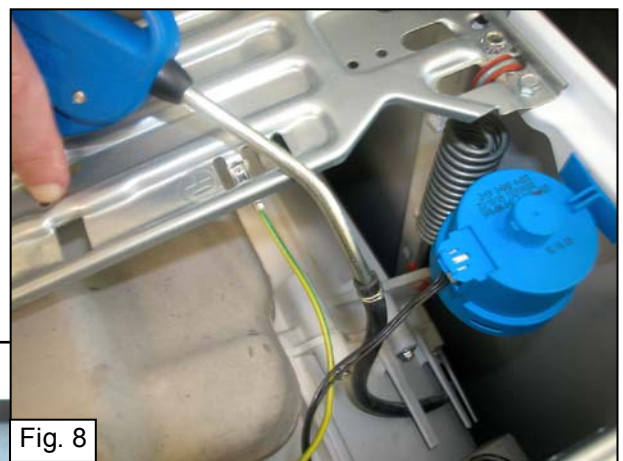
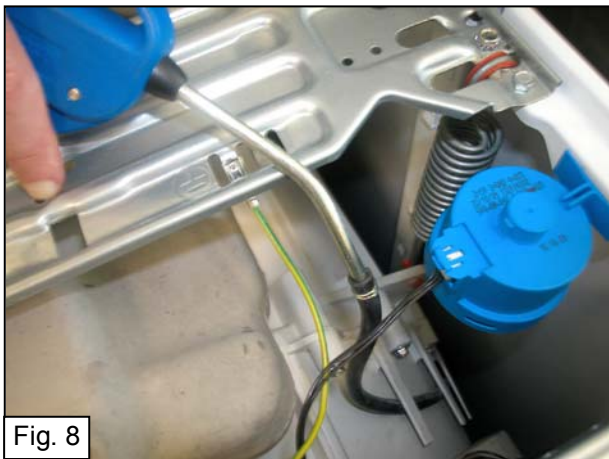
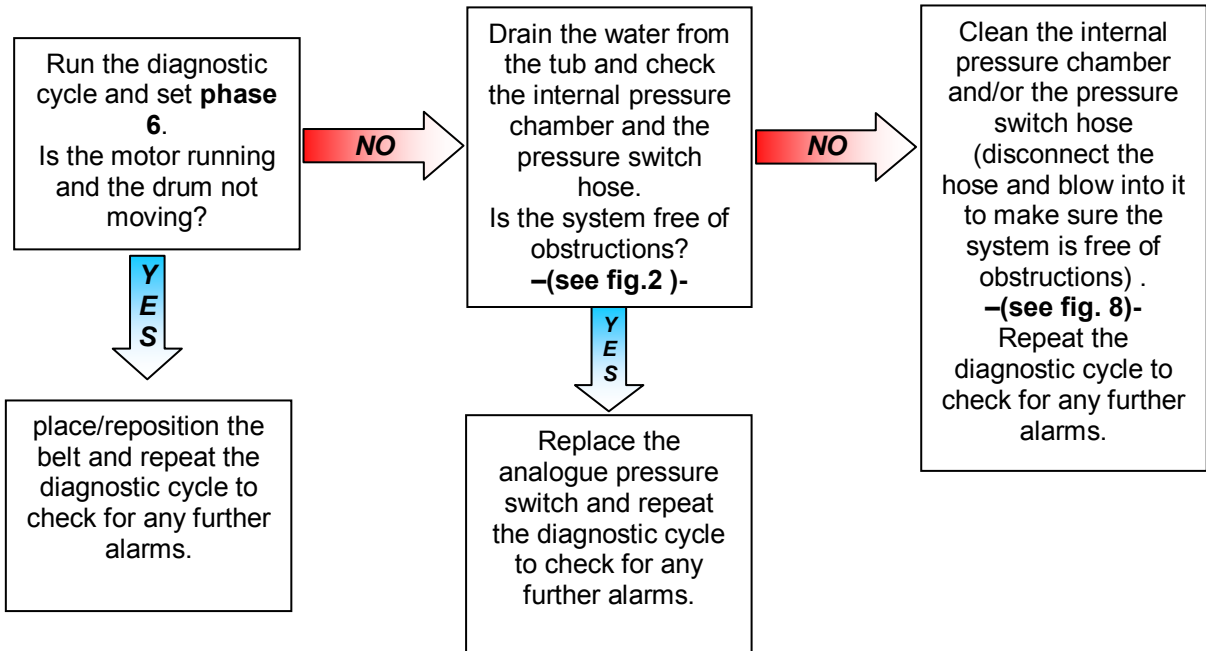

Fig. 8

If there are burns on the circuit board, see page 60

E38	E38: Internal pressure chamber is clogged	E38
	The analogue pressure switch is not able to measure any variation in the water level for at least 30 secs during drum rotation.	

Checks to perform: Check that all the connectors are inserted correctly



If there are burns on the circuit board, see page 60

E41	E41: Door open (device with 3 connections)	E41
	Maximum time exceeded (PTC = 15 seconds)	

Checks to perform: Check that all the connectors are inserted correctly

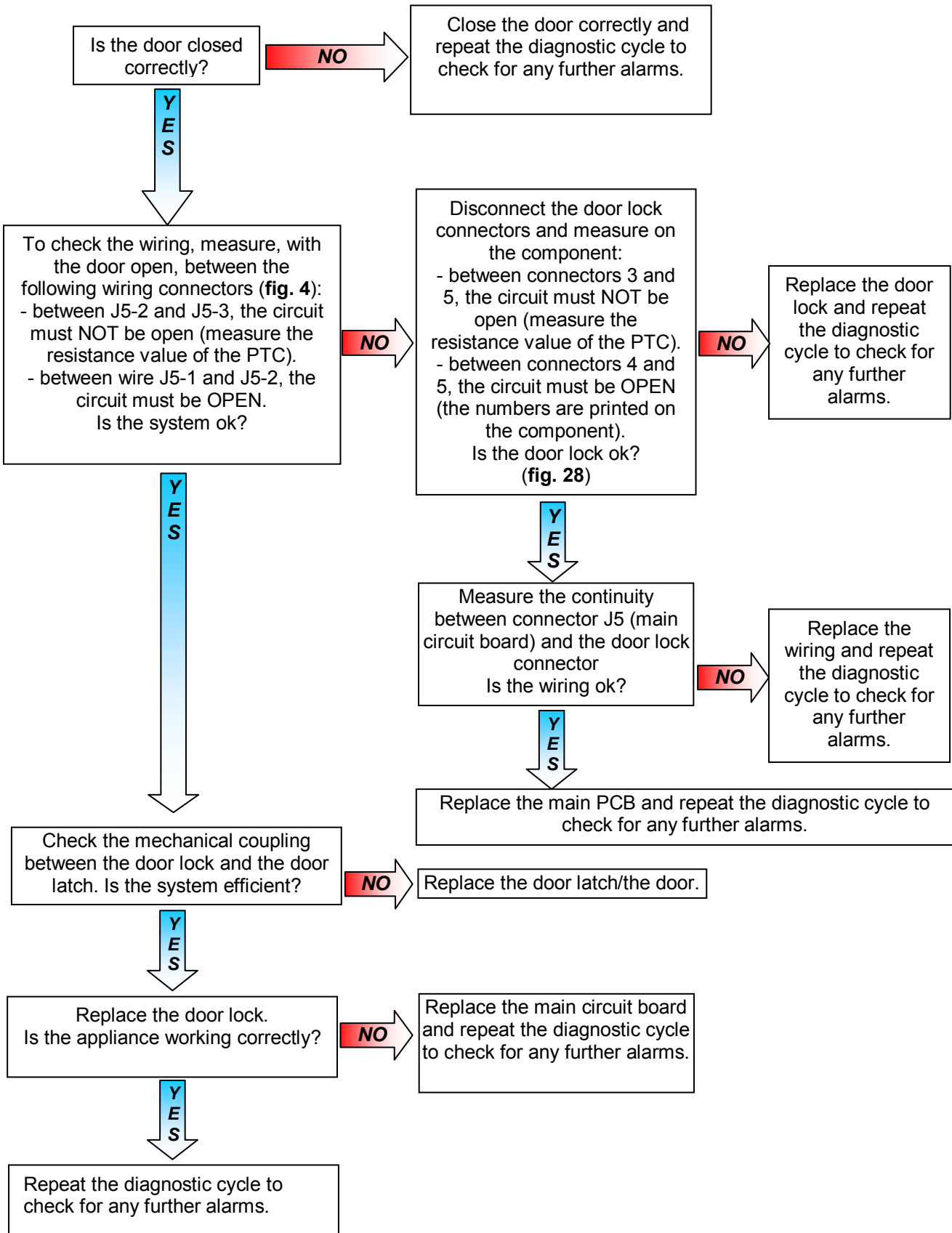

If there are burns on the circuit board, see page 60

E41 (device with 3 connections)

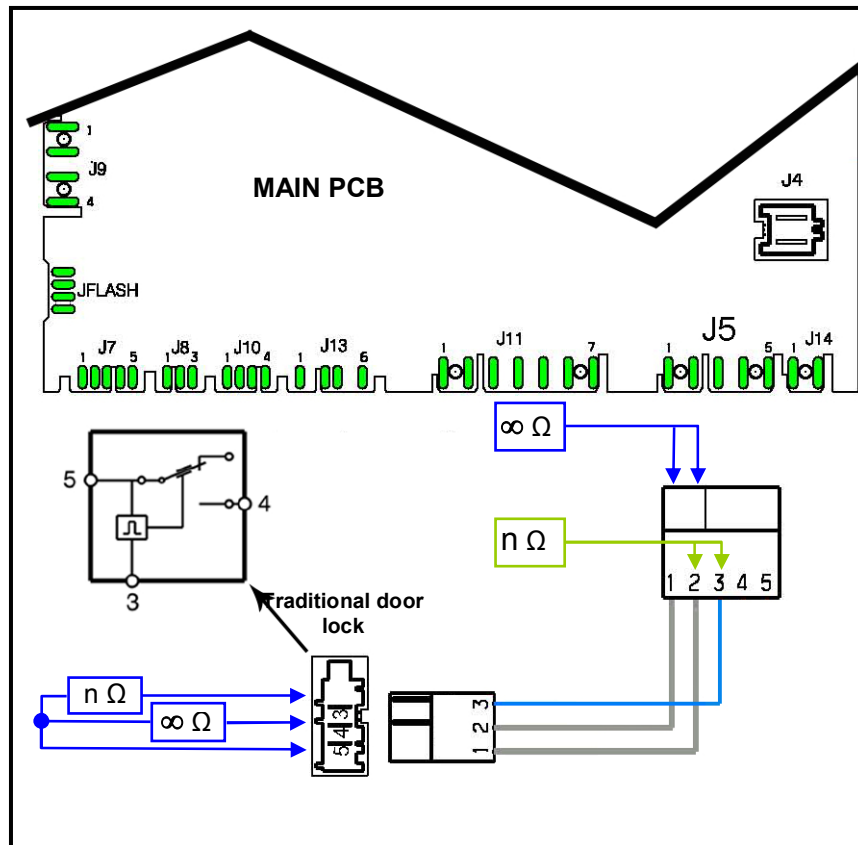
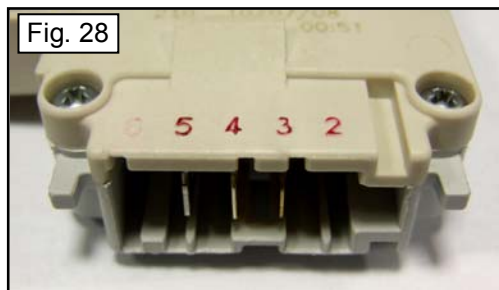
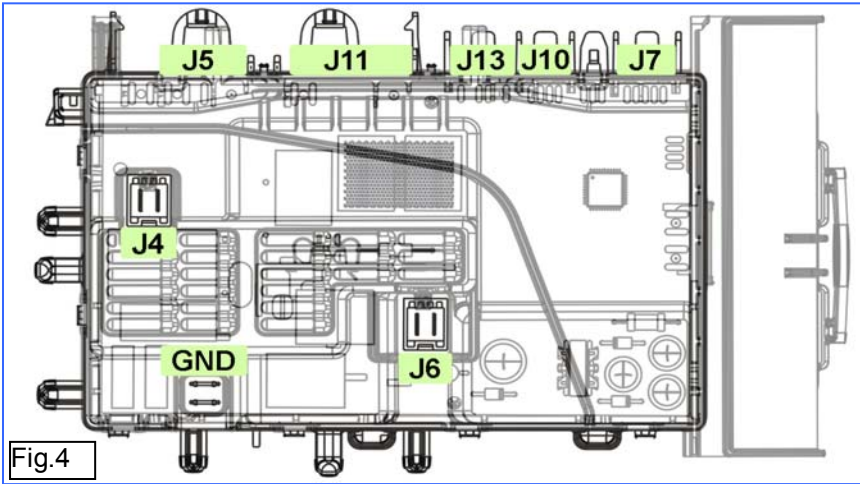

If there are burns on the circuit board, see page 60

E42	E42: Problems opening door (device with 3 connections)	E42
	Maximum time exceeded (255 seconds)	

Checks to perform: Check that all the connectors are inserted correctly

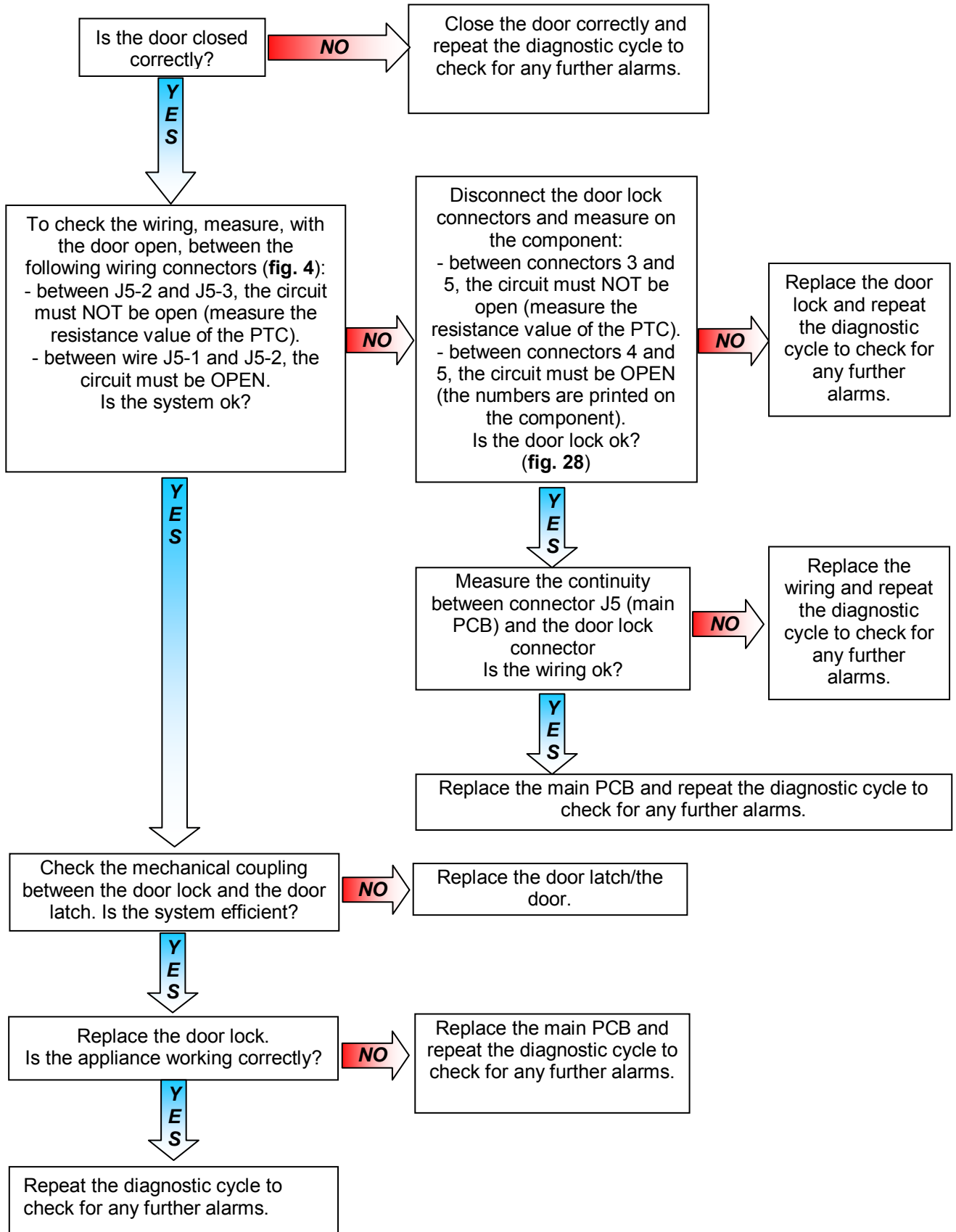

If there are burns on the circuit board, see page 60

E42 (device with 3 connections)

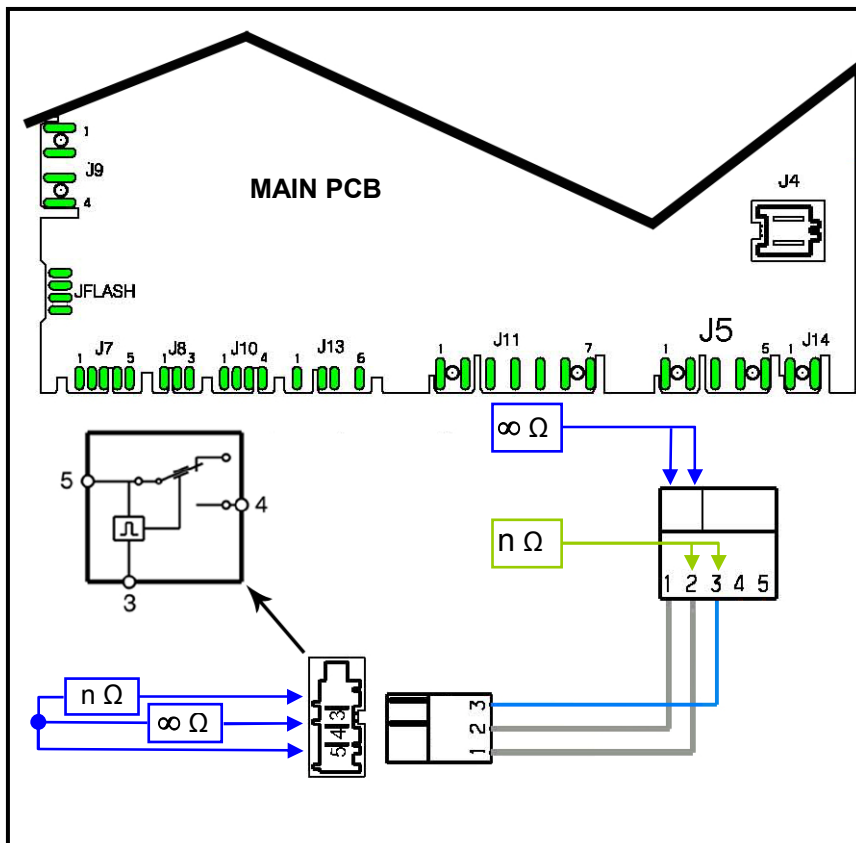
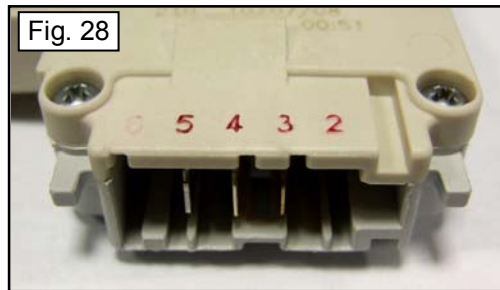
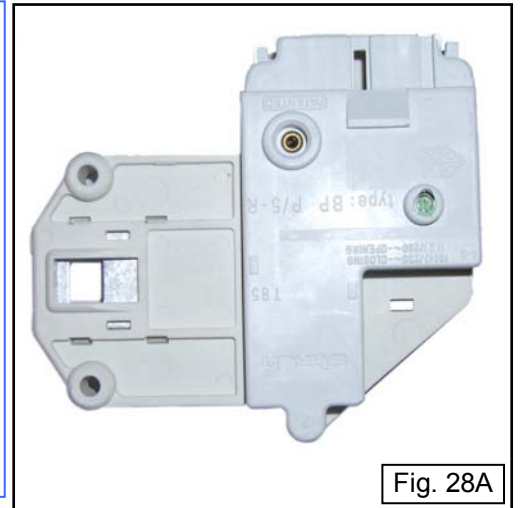
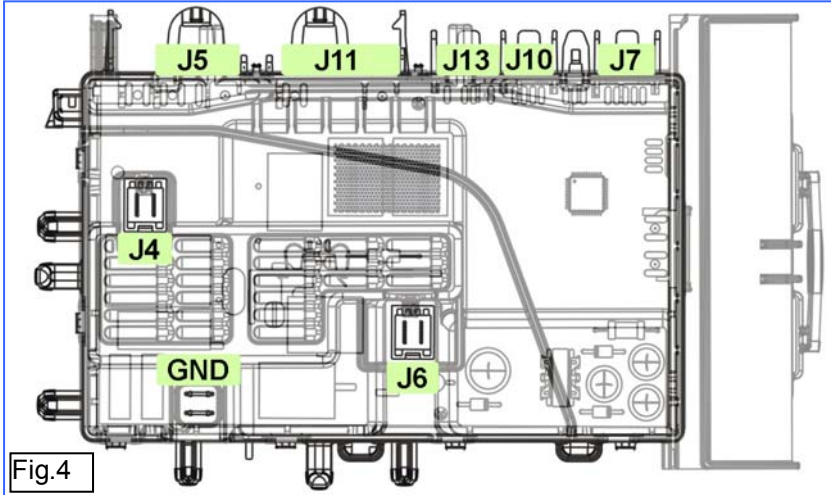

If there are burns on the circuit board, see page 60

E43	E43: Problems with the component (triac) controlling the door delay system (device with 3 connections)	E43
------------	---	------------

Checks to perform: Check that all the connectors are inserted correctly

To check the wiring, with the door open, measure between the following wiring connectors (fig. 4):

- between wire J5-2 and J5-3, the circuit must NOT be open (measure the resistance value of the PTC).
- between wire J5-1 and J5-2, the circuit must be OPEN.

Is the system ok?

YES

Replace the circuit board and repeat the diagnostic cycle to check for any further alarms.

NO

Disconnect the door lock connectors and measure on the component (fig. 28):

- between connectors 3 and 5, the circuit must NOT be open (measure the resistance value of the PTC).
- between connectors 4 and 5, the circuit must be OPEN (the numbers are printed on the component).

Is the door interlock ok?

YES

Measure the continuity between connector J5 (main PCB) and the door lock connector

Is the wiring ok?

YES

Replace the circuit board and repeat the diagnostic cycle to check for any further alarms.

NO

Replace the door lock and repeat the diagnostic cycle to check for any further alarms.

NO

Replace the wiring and repeat the diagnostic cycle to check for any further alarms

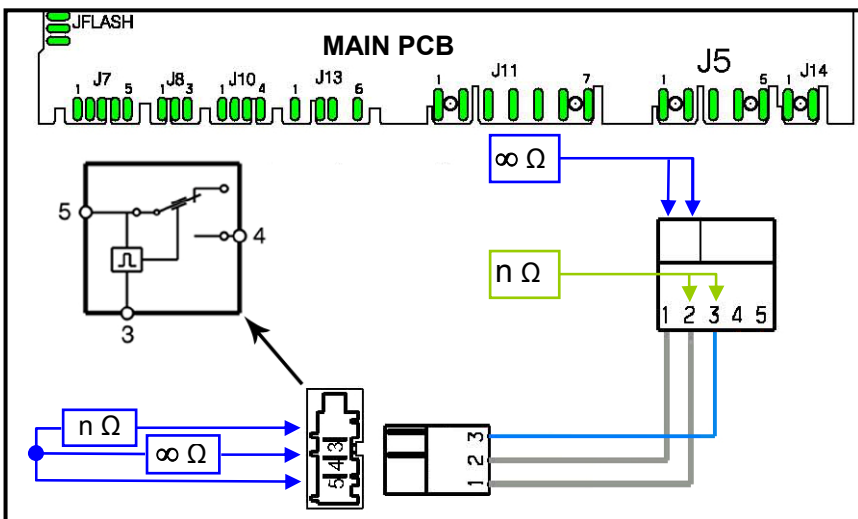
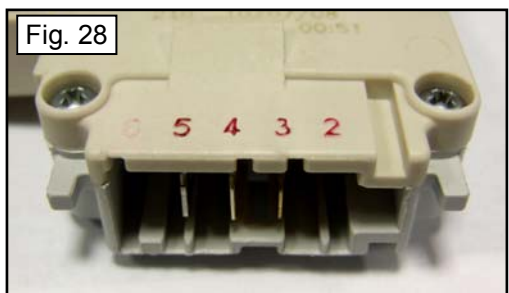
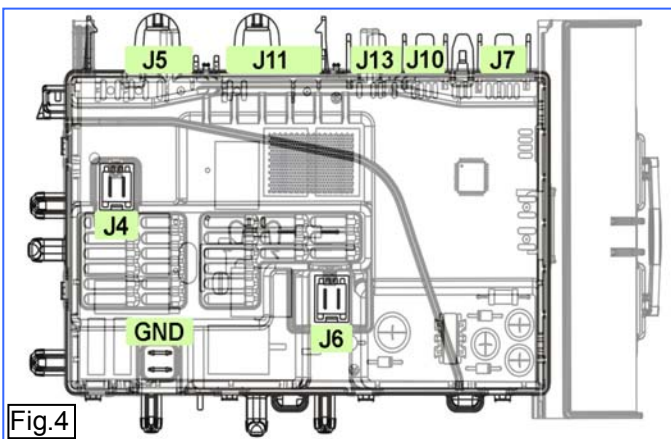

If there are burns on the circuit board, see page 60

E44	E44: Door closed "sensing" circuit faulty	E44
------------	--	------------

Checks to perform: Check that all the connectors are inserted correctly

Replace the circuit board and repeat the diagnostic cycle to check for any further alarms.

E45	E45: Problems with the "sensing" circuit of the component (triac) controlling the door delay system	E45
------------	--	------------

Checks to perform: Check that all the connectors are inserted correctly

Replace the circuit board and repeat the diagnostic cycle to check for any further alarms.

*If there are burns on the circuit board,
see page 60*

E51: Motor power triac short-circuited		
E51	Activation of the protection system for the triac short-circuit (after 5 attempts separated by a 5-minute pause, during the cycle, immediately if recognised at the start of the cycle or during diagnostics)	E51

Checks to perform:

Check that all the connectors are inserted correctly

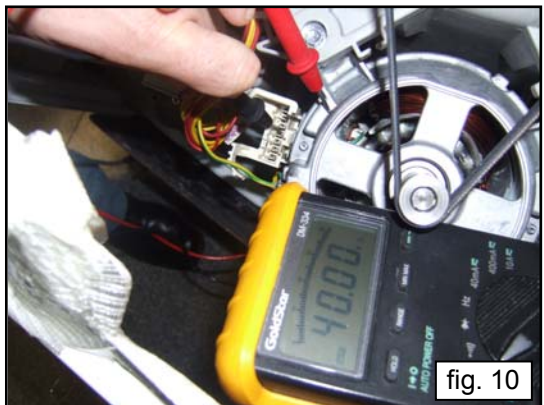
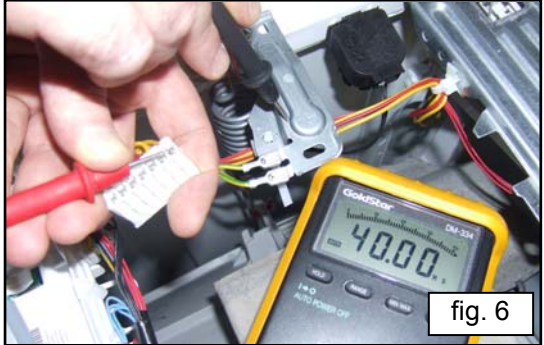
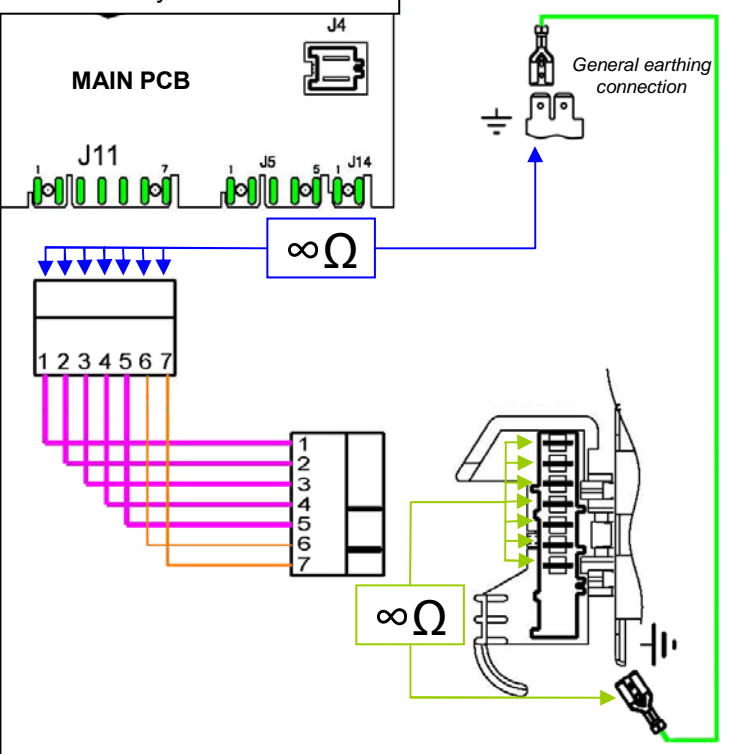
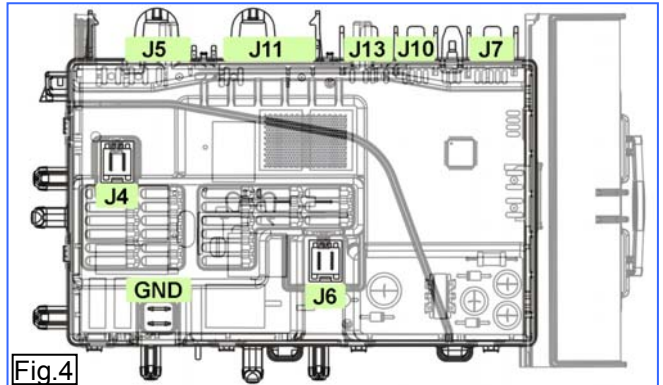
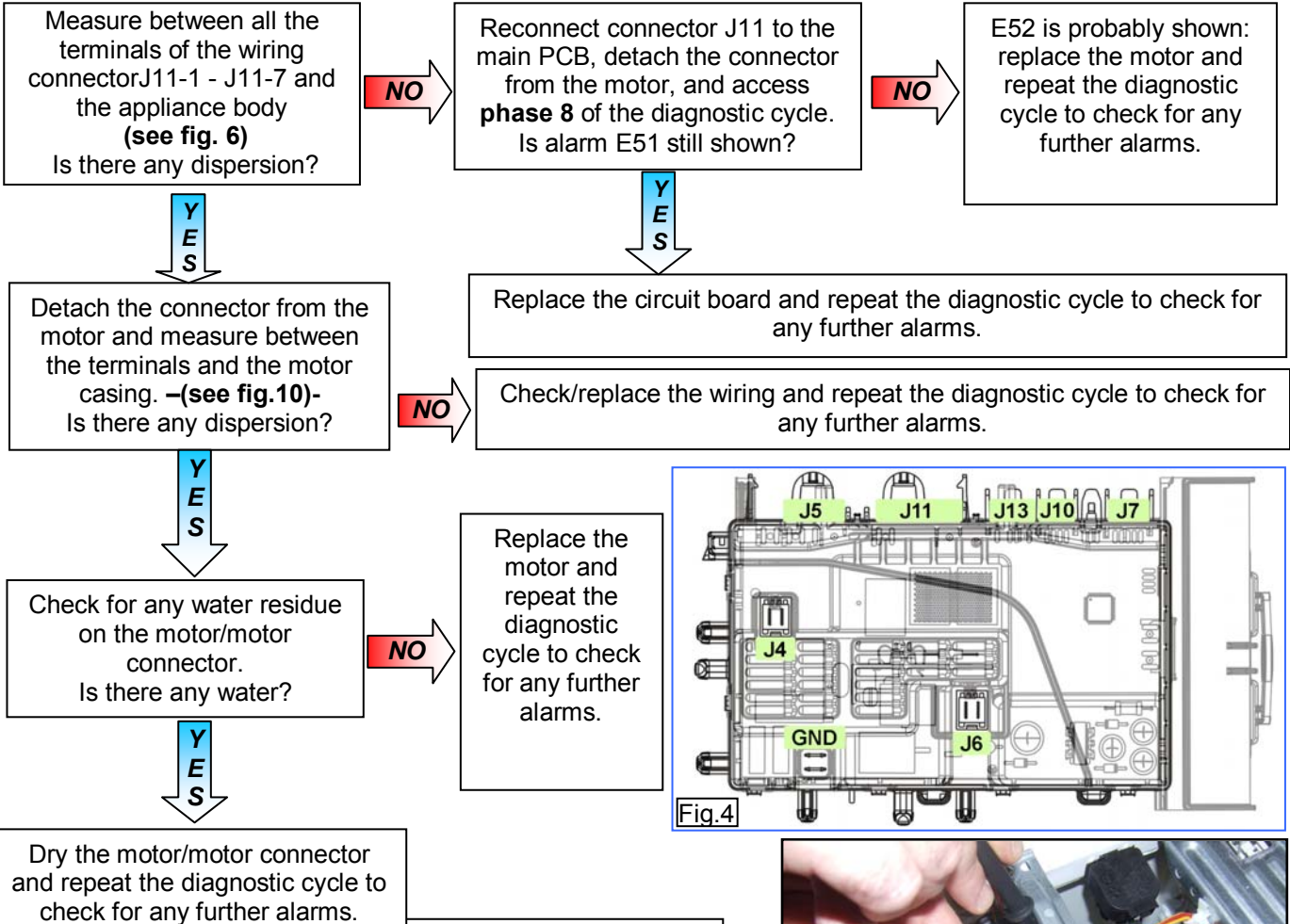

If there are burns on the circuit board, see page 60

E52	E52: No signal from motor tachometric generator (first part)	E52
	Cycle interrupted after 5 attempts during the cycle, immediately if recognised at the start of the cycle or during diagnostics.	

Checks to perform:

Check that all the connectors are inserted correctly

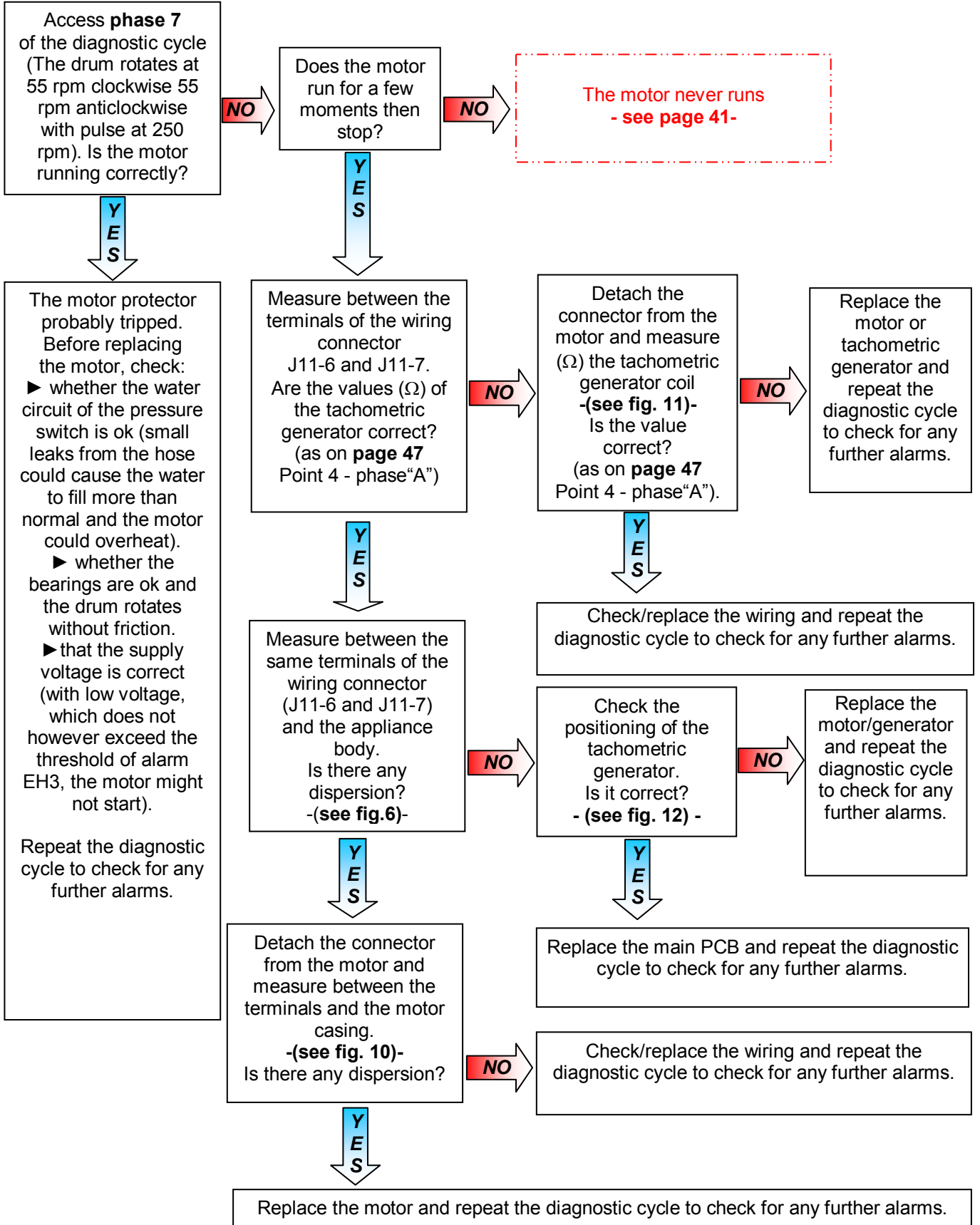

If there are burns on the circuit board, see page 60

E52

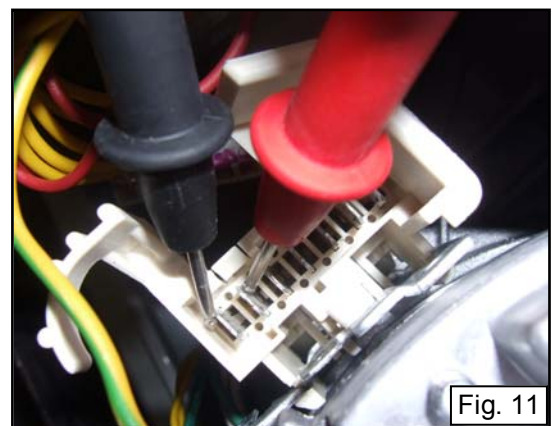
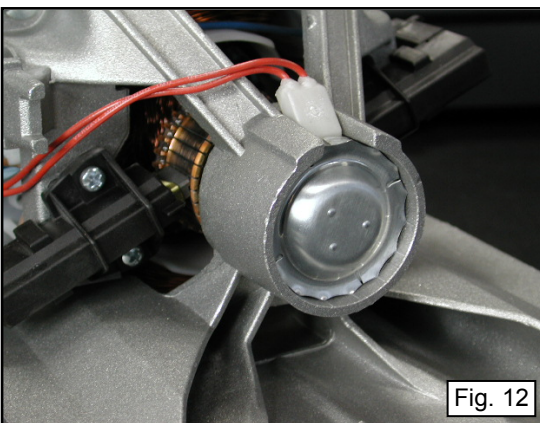
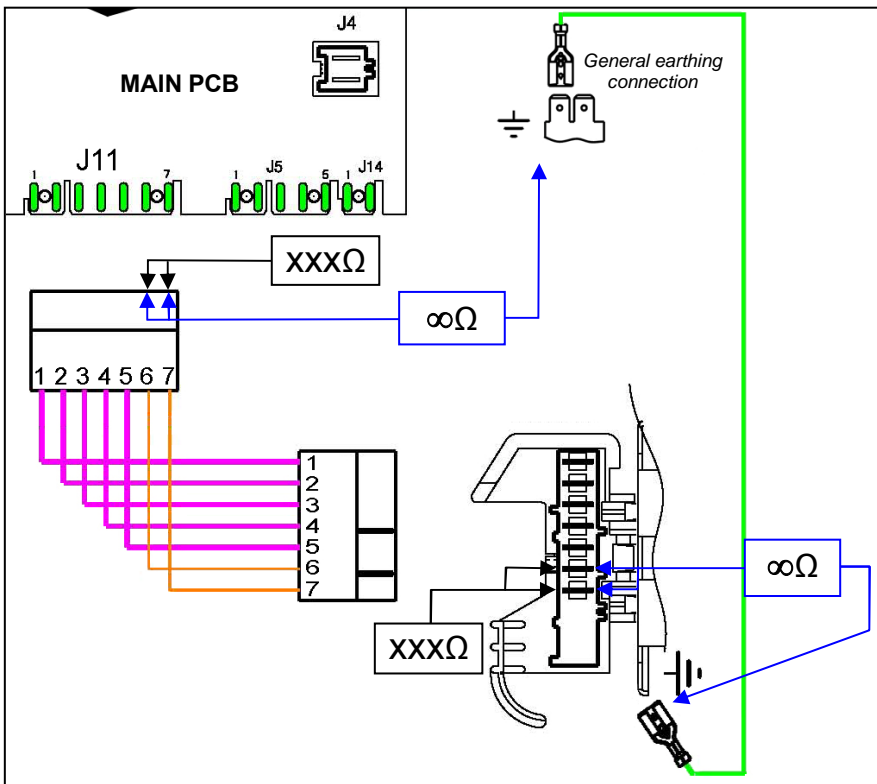
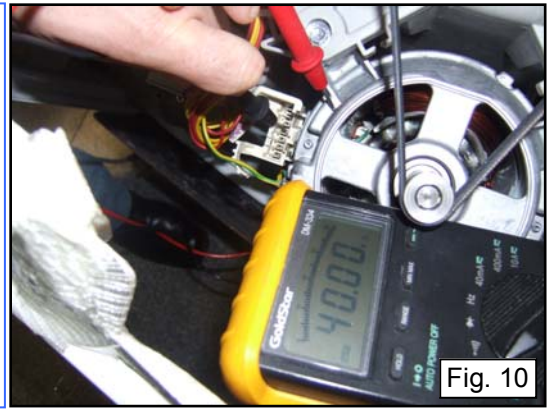
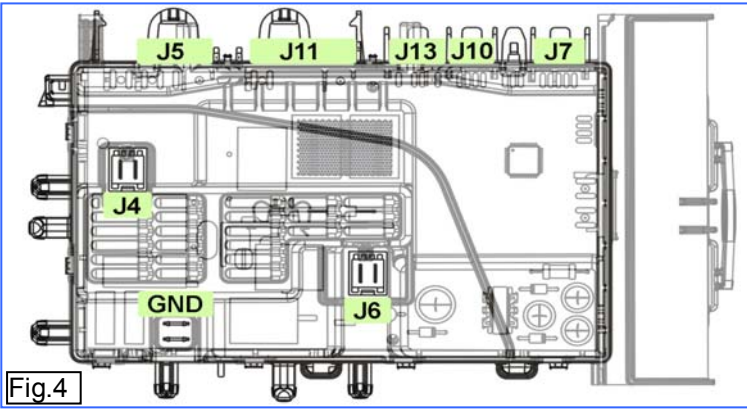

If there are burns on the circuit board, see page 60

E52	E52: No signal from motor tachometric generator (second part) Cycle interrupted after 5 attempts during the cycle, immediately if recognised at the start of the cycle or during diagnostics.	E52
------------	---	------------

Checks to perform: Check that all the connectors are inserted correctly

The motor never runs

To check the wiring, measure (Ω) between the following wiring connectors of the main PCB (fig.4) and compare the values with the correct ones (see page 47: point 4 - motor parameters)

- between J11-2 and J11-5, a value as in point - **B** (Stator) must be found
- between J11-1 and J11-5, where featured, a value as in point 4 - **D** must be found (half field stator).
- between J11-3 and J11-4, a value as in point - **C** (rotor) must be found.

Are the values correct?

NO →

Check the motor as on page 47. Is the motor ok?

NO →

Replace the motor and repeat the diagnostic cycle to check for any further alarms.

YES

Check/replace the wiring and repeat the diagnostic cycle to check for any further alarms.

YES

Replace the circuit board and repeat the diagnostic cycle to check for any further alarms.

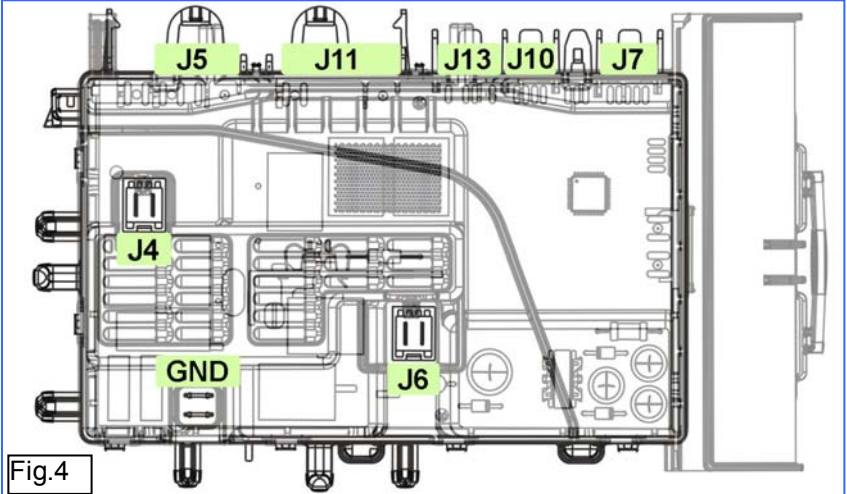

Fig.4

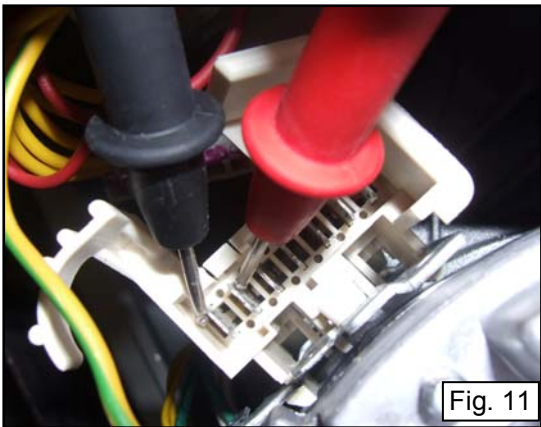
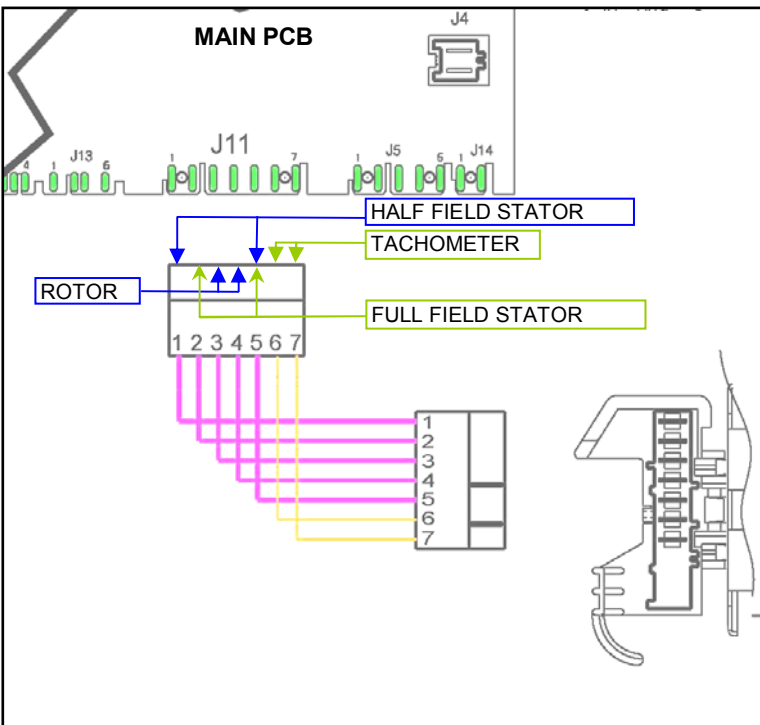
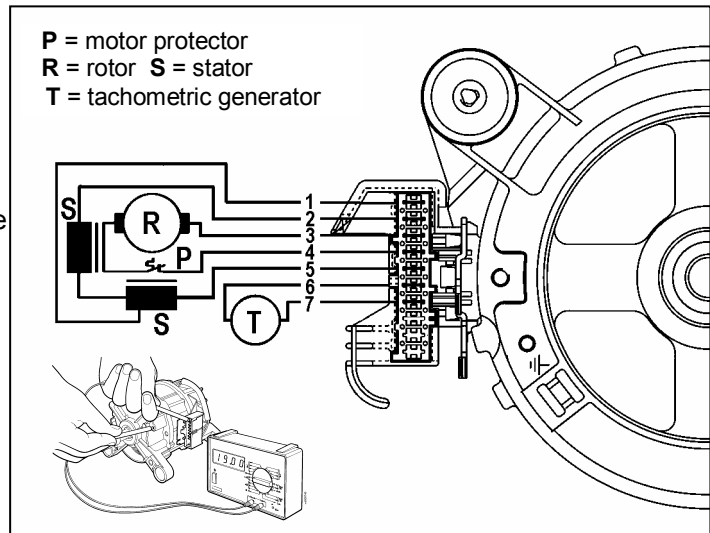

Fig. 11

If there are burns on the circuit board, see page 60

How to check collector motors

- 1) Check the connection blocks (wiring) and for the presence of any protruding/kinked terminals.
- 2) Check for the presence of any marks / residue / water or detergent deposits on the motor and where these come from.
- 3) Then check for any windings / earthed parts or parts with poor earthing insulation. Use a tester with a minimum capacity of 40 M Ω : between each individual terminal and the motor casing, read ∞ (**fig. 10**)
- 4) Then check each individual winding according to the following table (**fig. 11**).



	MOTOR TERMINAL BLOCK	CONTROLS:	MOTOR WELLING
A	6-7	Generator tachimeter winding	103 Ω
B	2-5	Stator winding (all fields)	1,62 Ω
C	3-4	Rotor winding (plus heat protector)	1.24 Ω
D	1-5	Stator winding (half-field presence terminal 1)	0.8 Ω

The tolerance for the resistance values for the windings is $\pm 7\%$

Note: when checking the rotor winding, the measurement must be made along the entire profile, turning the shaft very slowly and checking for the presence of any short circuits between visible blades. Also check the condition of the brushes.

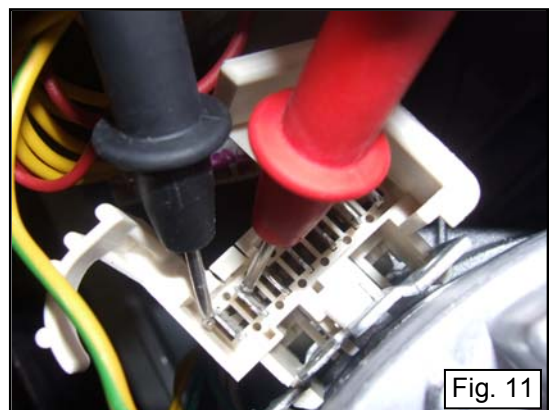
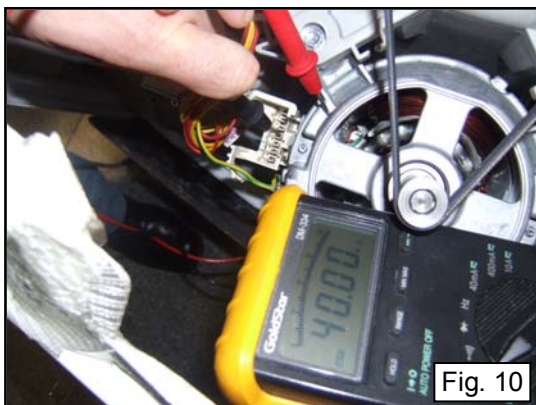

E53	E53: Problems with the "sensing" circuit of the component (triac) powering the motor	E53
------------	---	------------

Checks to perform: Check that all the connectors are inserted correctly

Replace the circuit board and repeat the diagnostic cycle to check for any further alarms

*If there are burns on the circuit board,
see page 60*

E54	E54: Motor relay contacts sticking	E54
	Voltage value on the motor circuit even when this should not be operating	

Checks to perform: Check that all the connectors are inserted correctly

Measure between all the terminals of the wiring connector J11-1 - J11-5 and the appliance body - see page 47 - point 3
Is there any dispersion? - (see fig. 6) -

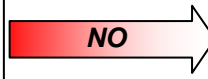

Replace the circuit board and repeat the diagnostic cycle to check for any further alarms.



Detach the connector from the motor and measure between the terminals and the motor casing. -(see fig. 10) -
Is there any dispersion?

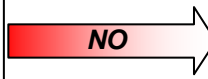

Check/replace the wiring and repeat the diagnostic cycle to check for any further alarms.



Replace the motor and repeat the diagnostic cycle to check for any further alarms.

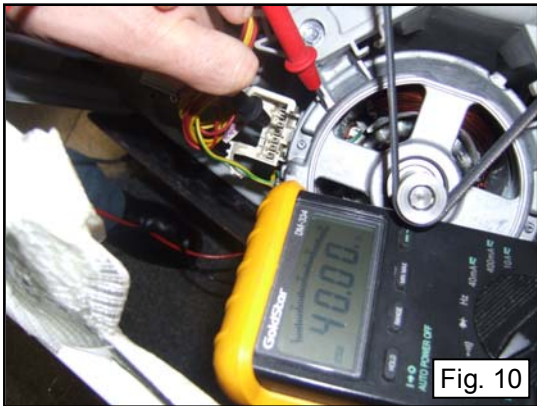

Fig. 10

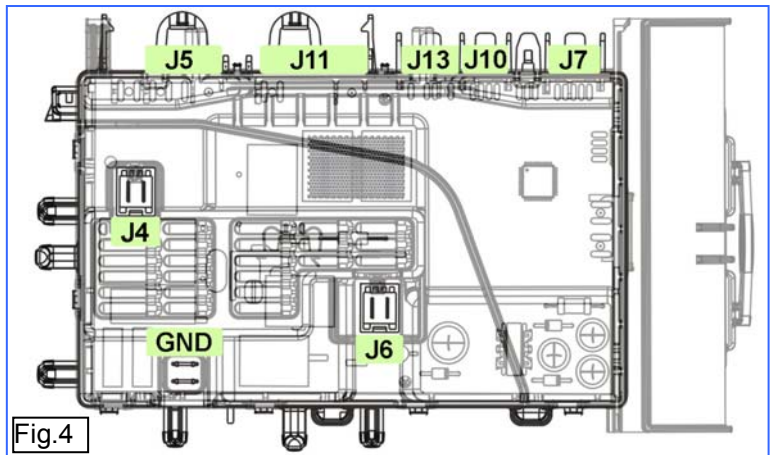

Fig.4

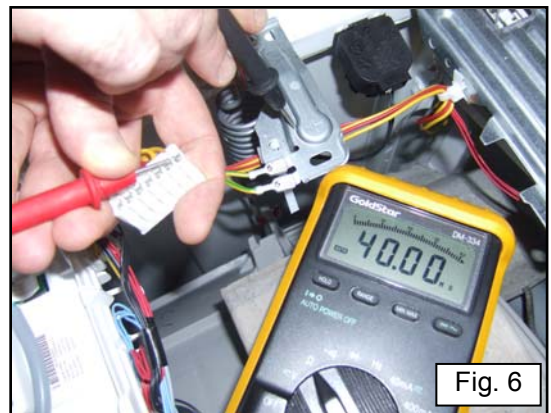
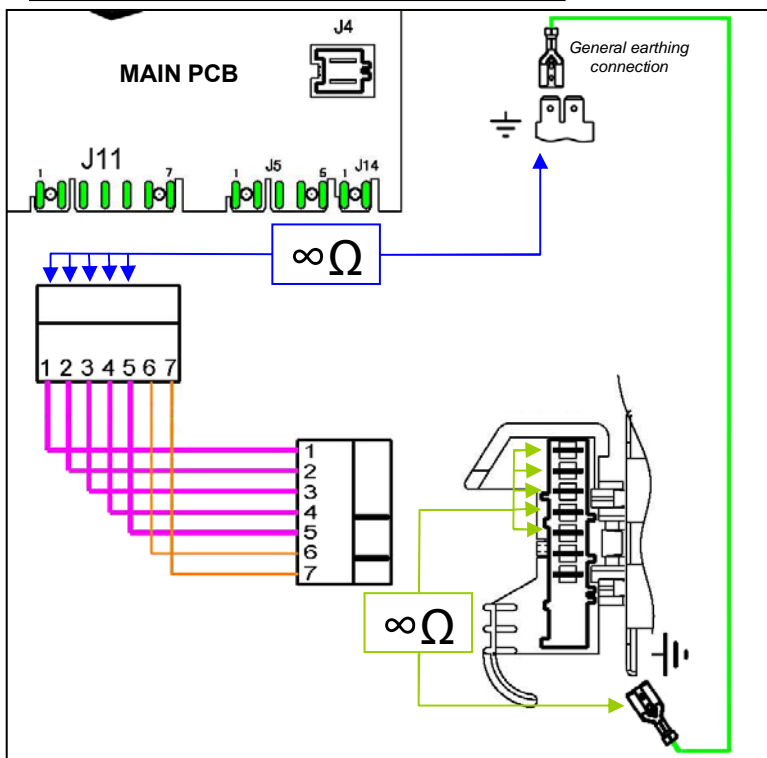
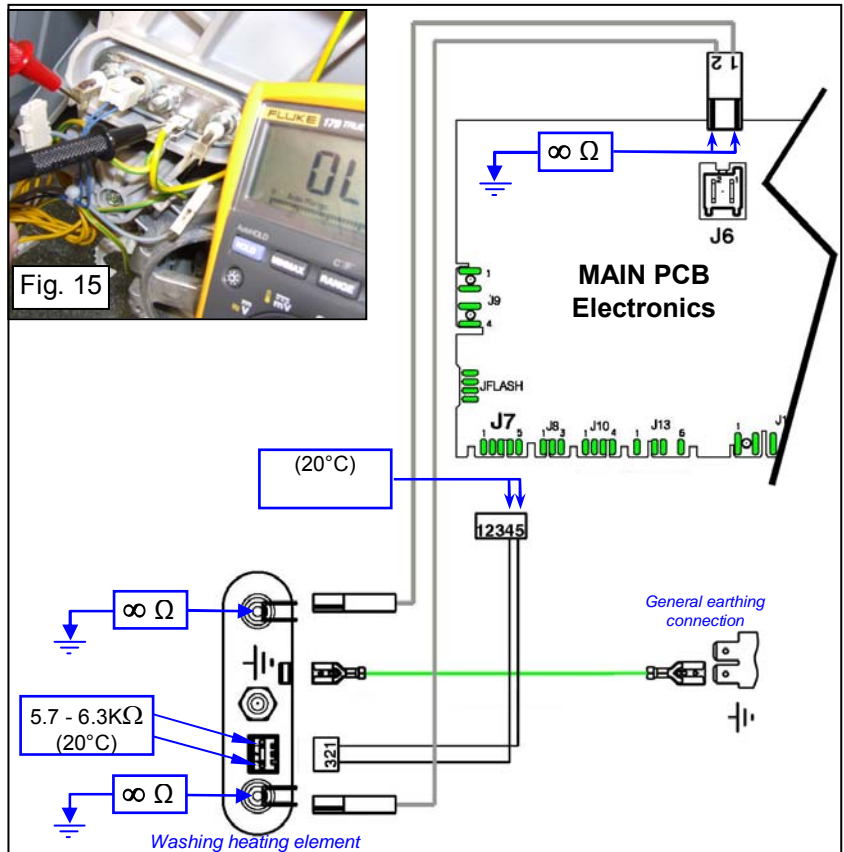
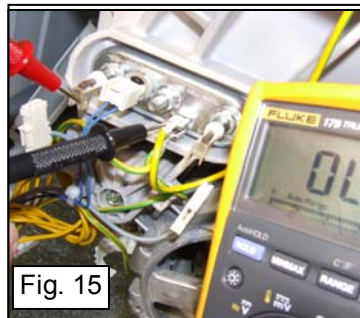
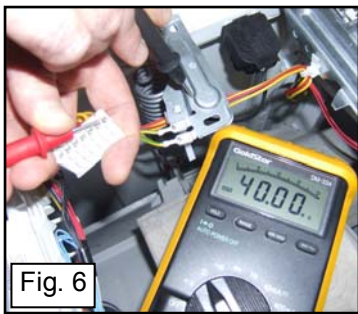
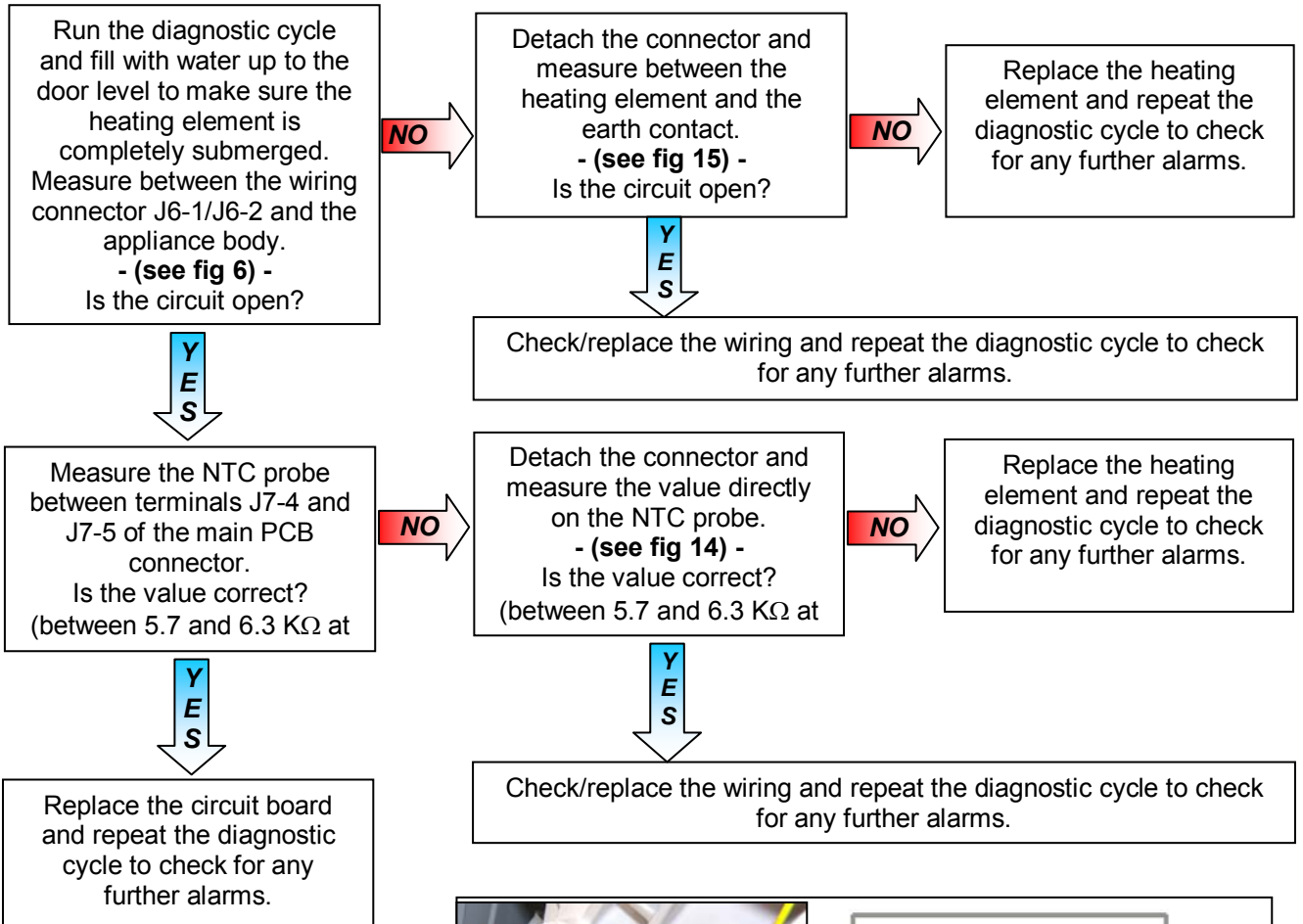

Fig. 6

If there are burns on the circuit board, see page 60

E62	E62: Overheating during washing	E62
The temperature of the NTC probe exceeds 88°C for more than 5 mins.		

Checks to perform: Check that all the connectors are inserted correctly



If there are burns on the circuit board, see page 60

E66 **E66: Heating element power supply relay faulty** **E66**

Checks to perform: Check that all the connectors are inserted correctly

Measure between the connector J6-1/J6-2 of the main PCB and the appliance body. (Fig. 6)
Is there any dispersion?

NO

Replace the circuit board and repeat the diagnostic cycle to check for any further alarms.

YES

Detach the connector J6 and measure between the heating element and the earth contact.
- fig. 15- Is the circuit open?

NO

Replace the heating element and repeat the diagnostic cycle to check for any further alarms.

YES

Check/replace the wiring and repeat the diagnostic cycle to check for any further alarms.

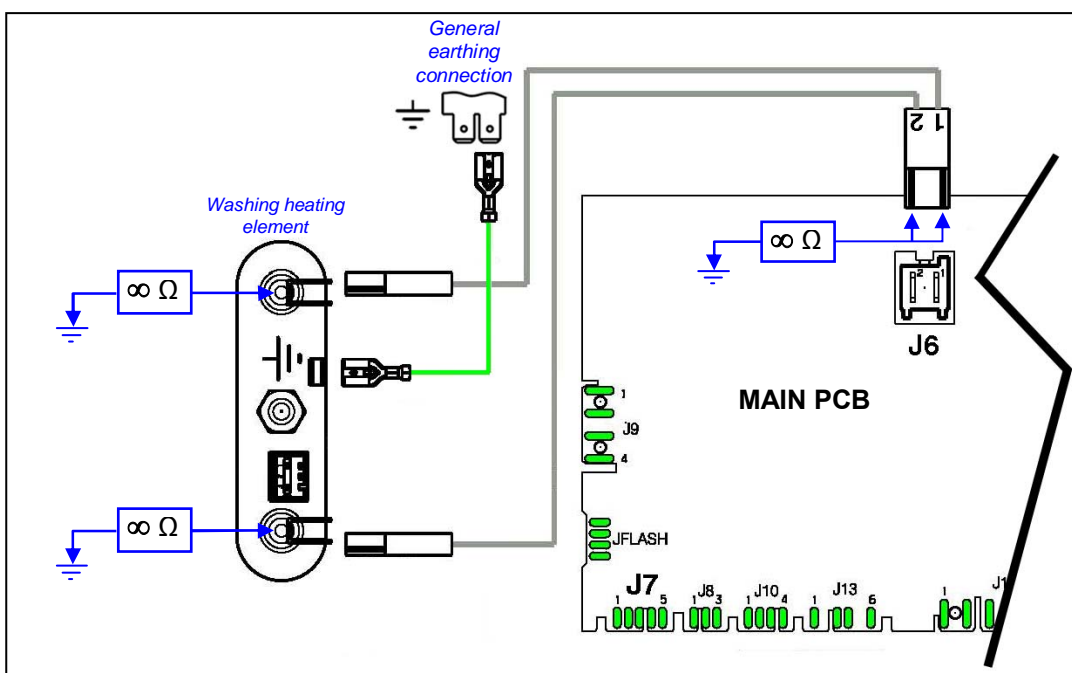
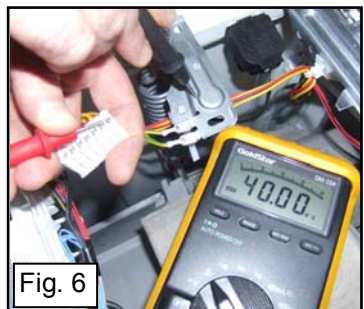
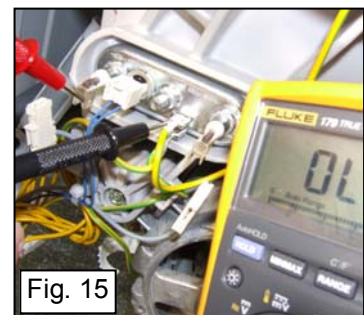
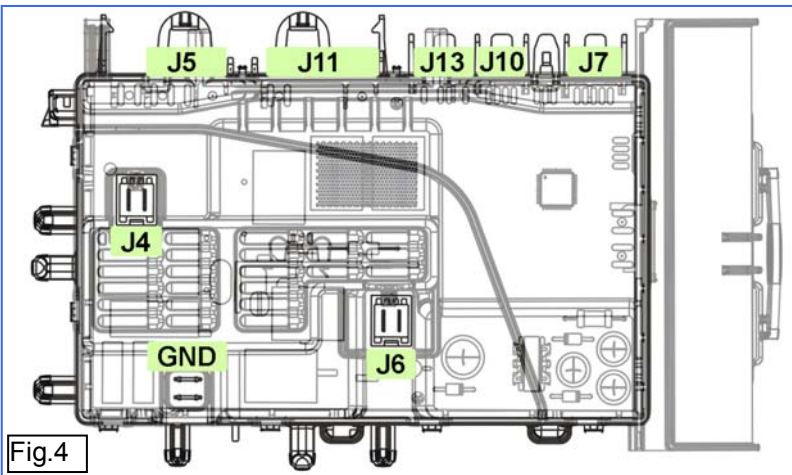

If there are burns on the circuit board, see page 60

E68	E68: Washing heating element leakage	E68
------------	---	------------

Checks to perform: Check that all the connectors are inserted correctly

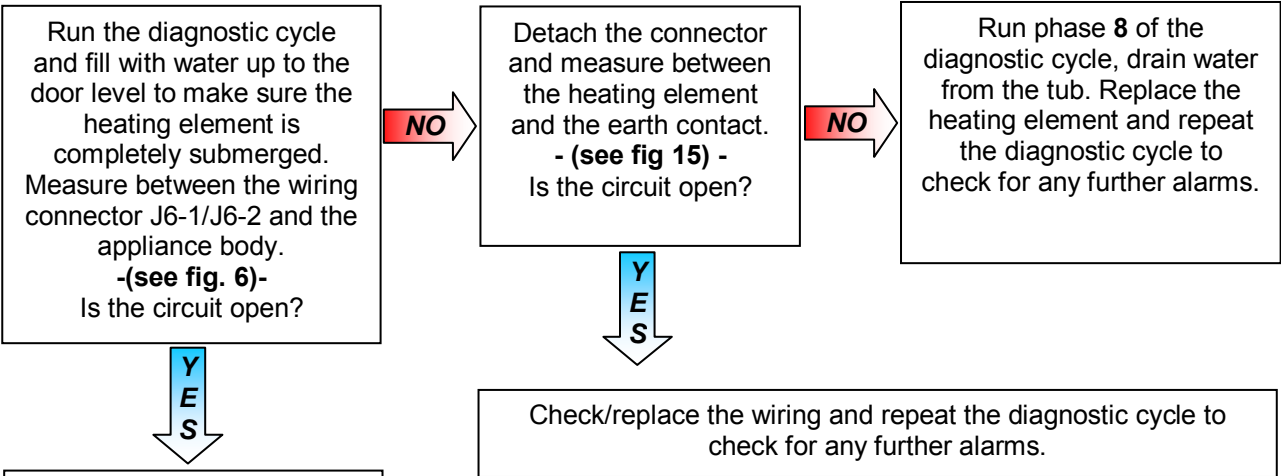

Replace the main circuit board and repeat the diagnostic cycle to check for any further alarms

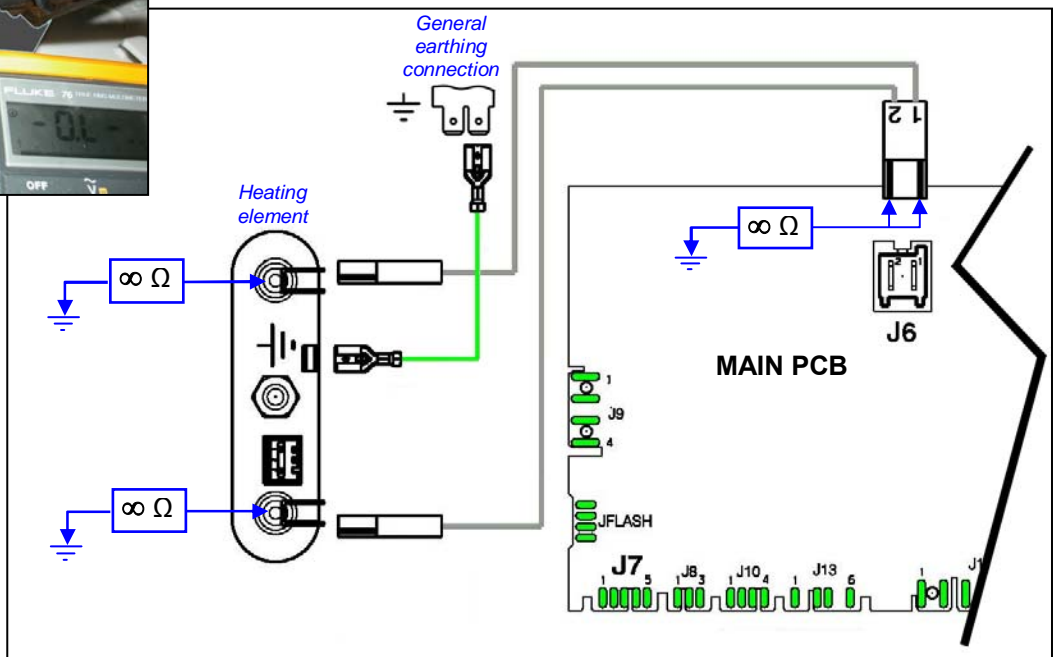
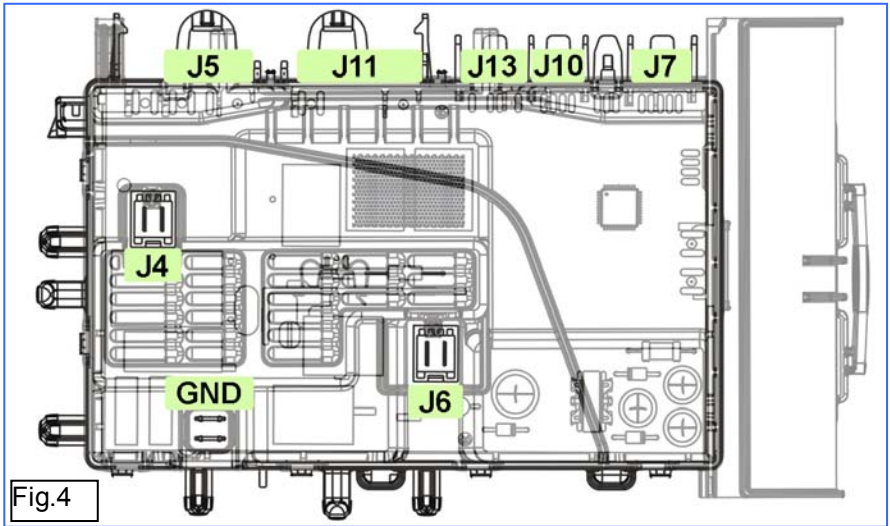
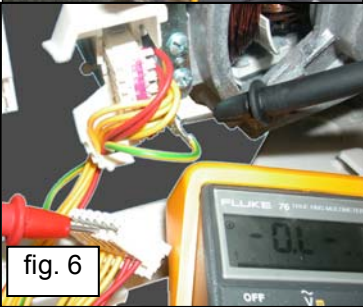
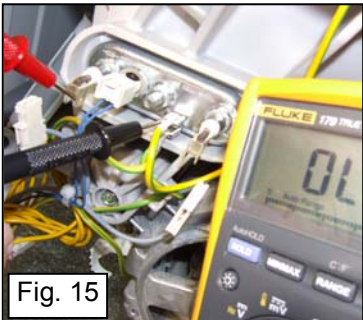

If there are burns on the circuit board, see page 60

E69	E69: Washing heating element damaged	E69
------------	---	------------

Checks to perform: *Check that all the connectors are inserted correctly*

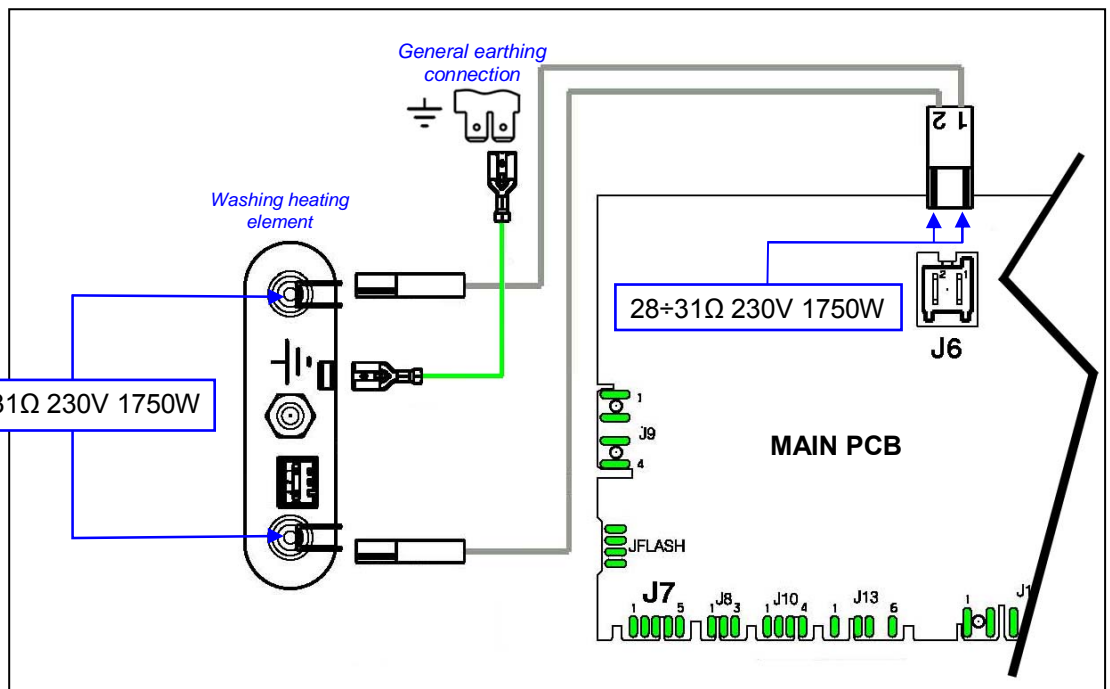
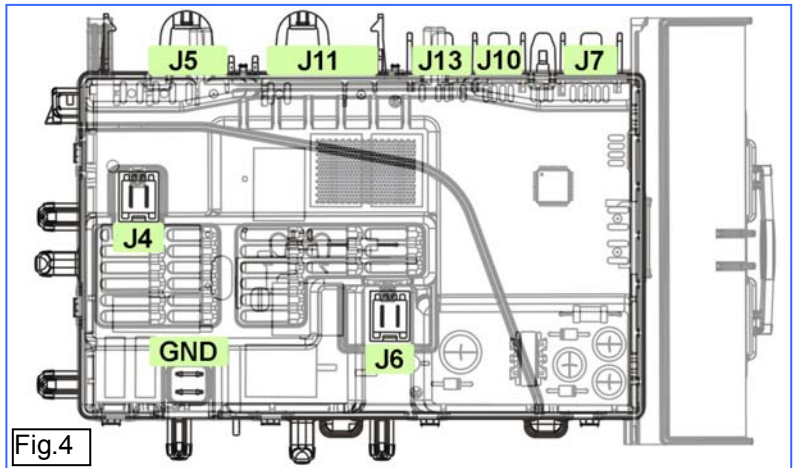
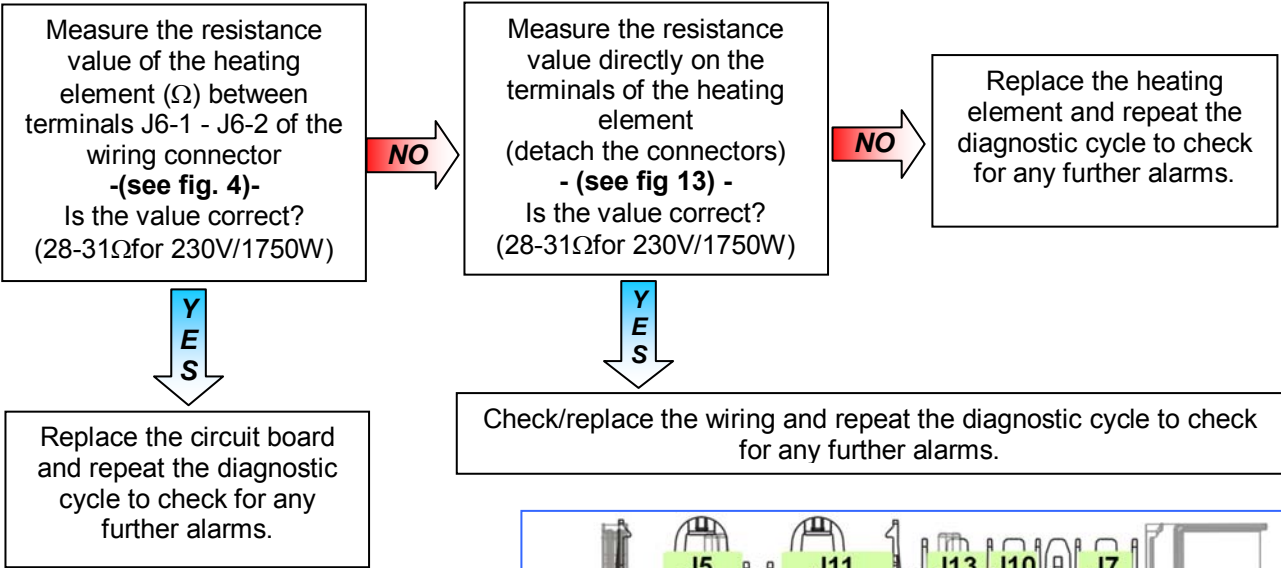

If there are burns on the circuit board, see page 60

E6A	E6A: Heating relay sensing faulty	E6A
------------	--	------------

Checks to perform: Check that all the connectors are inserted correctly

Replace the circuit board and repeat the diagnostic cycle to check for any further alarms

If there are burns on the circuit board, see page 60

E6H	E6H: Heating element power relay faulty (incongruence between sensing and relay status)	E6H
------------	--	------------

Checks to perform: Check that all the connectors are inserted correctly

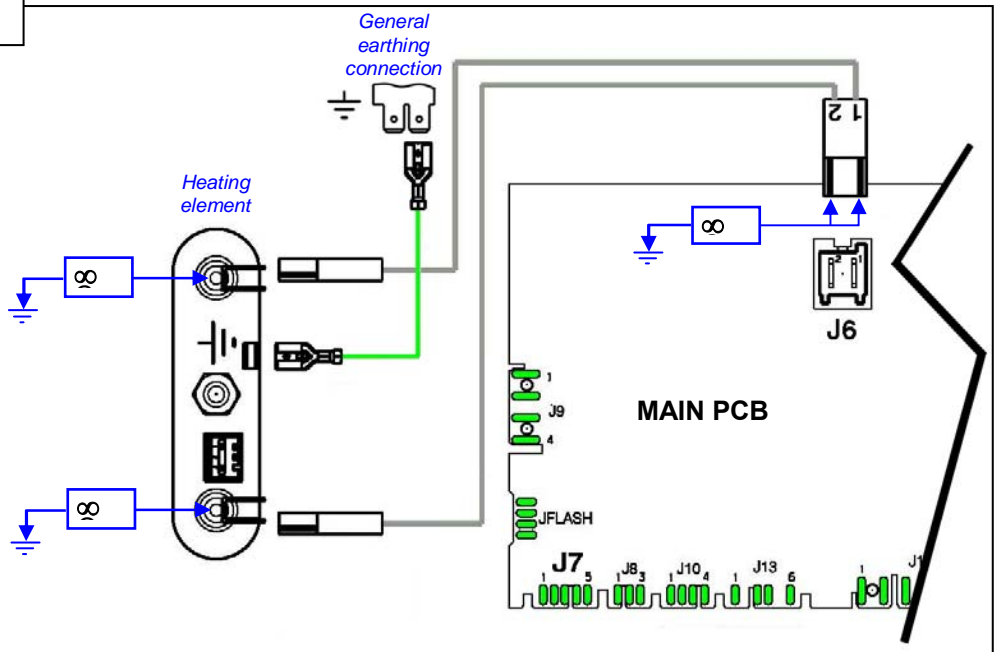
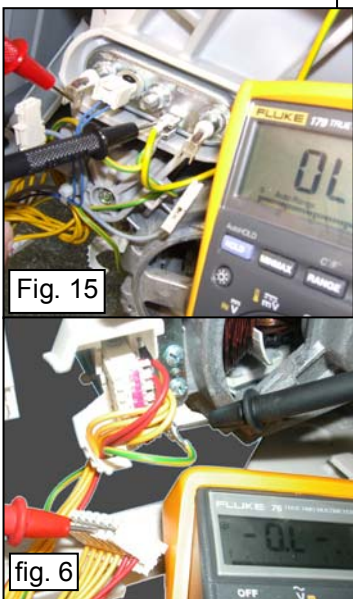
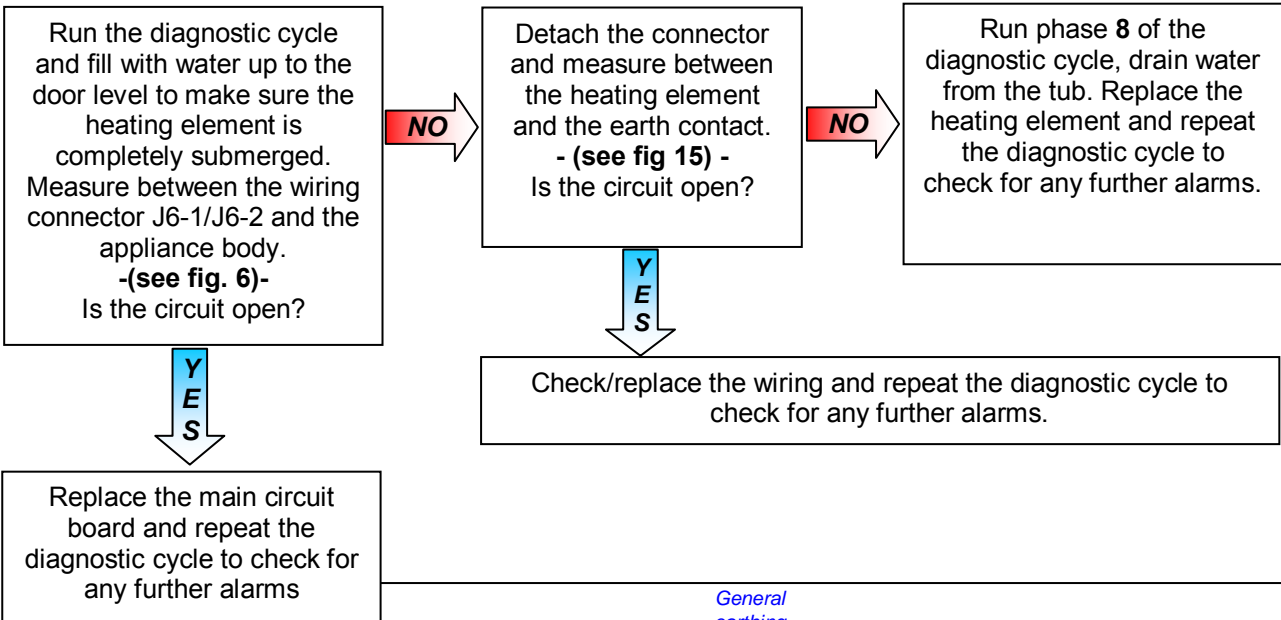

If there are burns on the circuit board, see page 60

E71	E71: Washing NTC probe faulty	E71
Voltage value out of range (short-circuit or open circuit)		

Checks to perform: Check that all the connectors are inserted correctly

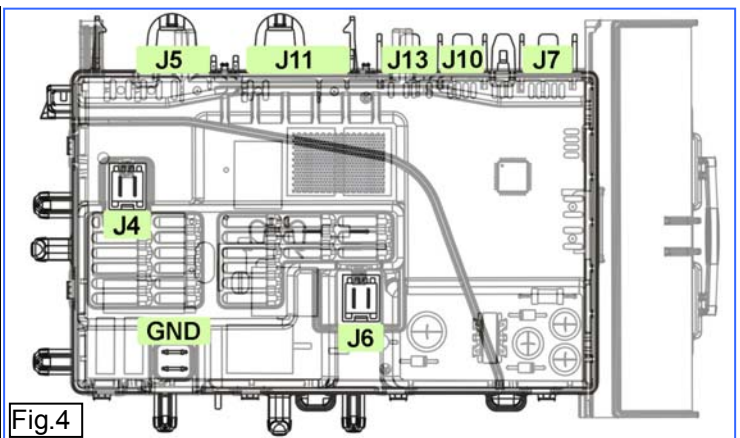
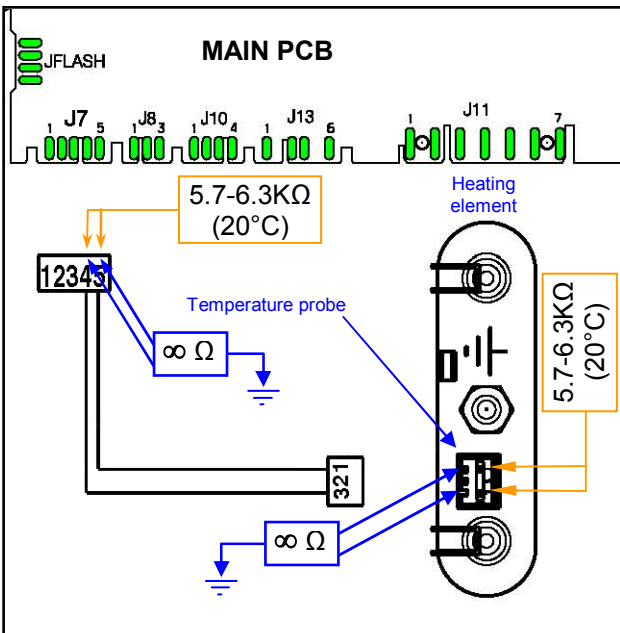
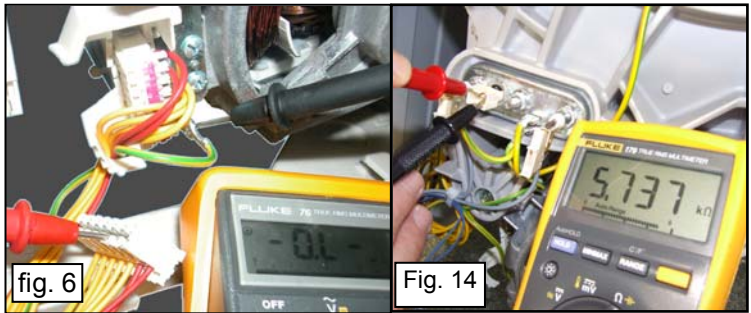
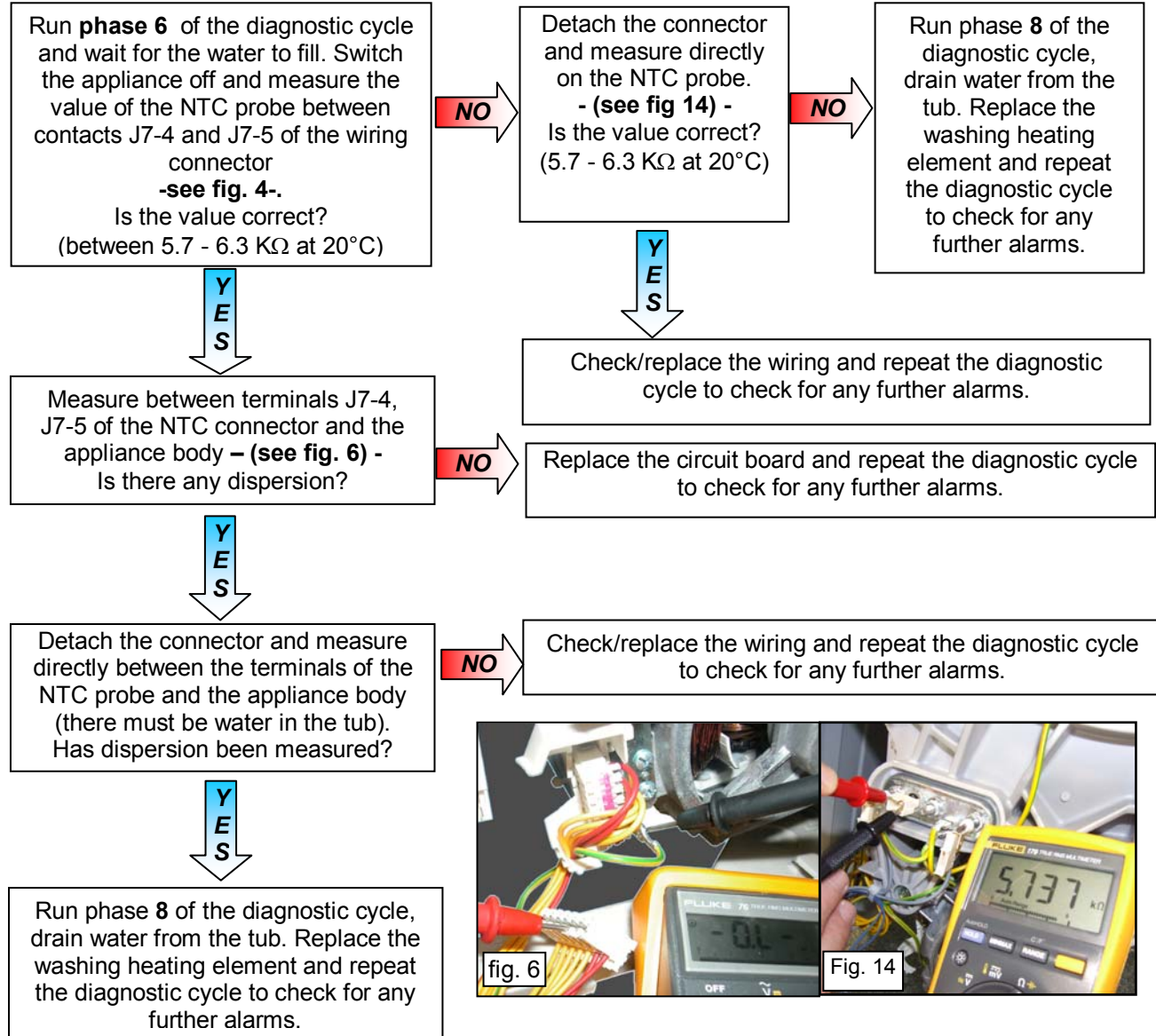

If there are burns on the circuit board, see page 60

E74 **E74: NTC probe improperly positioned** **E74**

Checks to perform: Check that all the connectors are inserted correctly

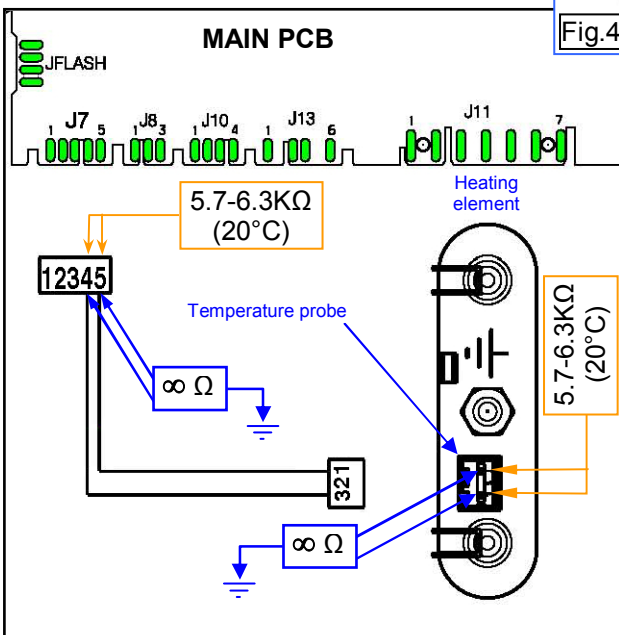
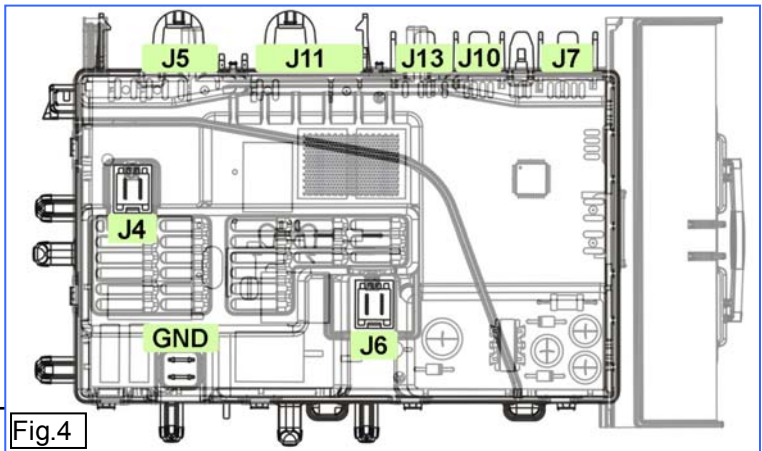
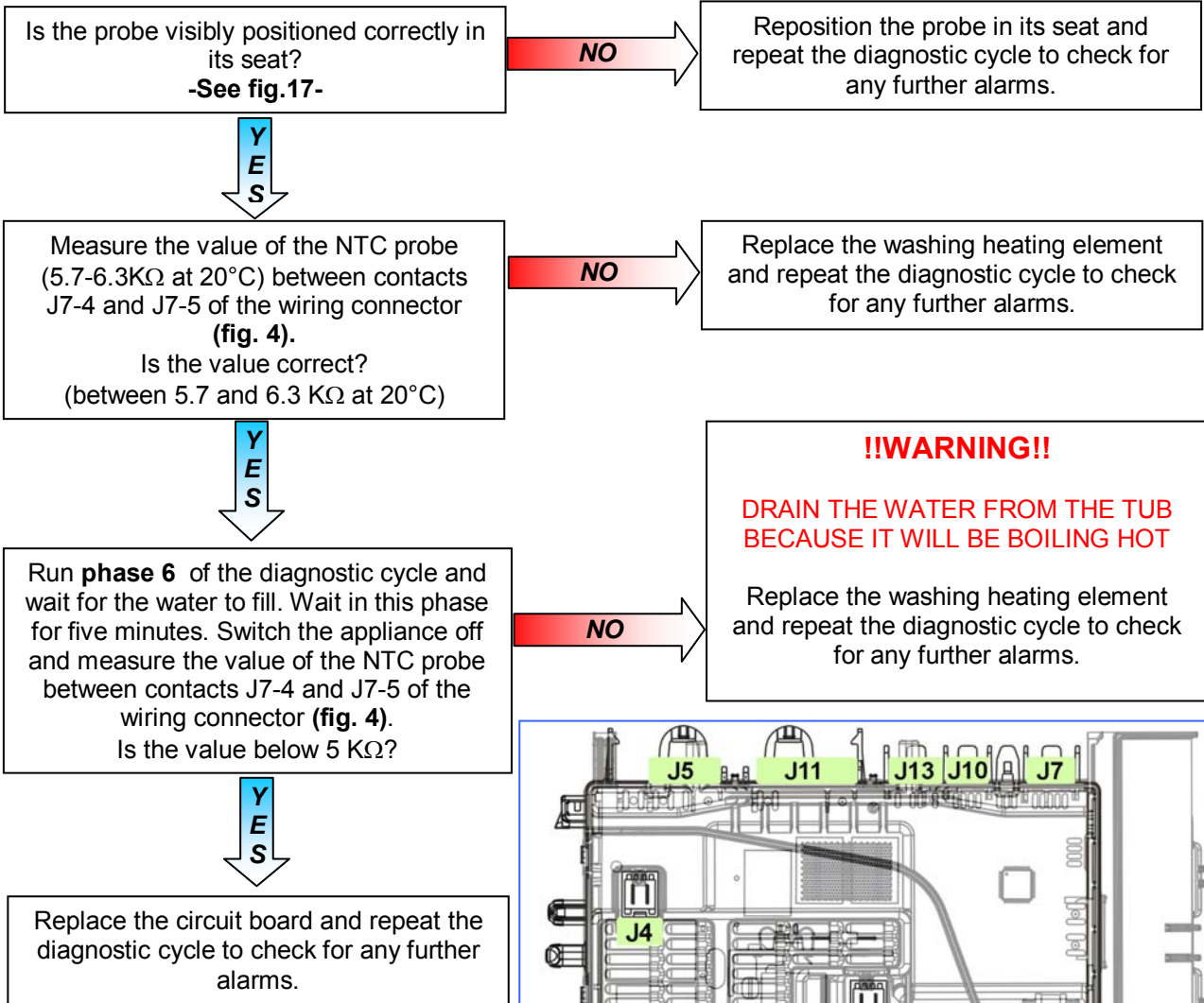

If there are burns on the circuit board, see page 60

E83	E83: Error reading the programme selector code	E83
	Selector position code not envisaged by the configuration data or configuration error	

Checks to perform: Check that all the connectors are inserted correctly

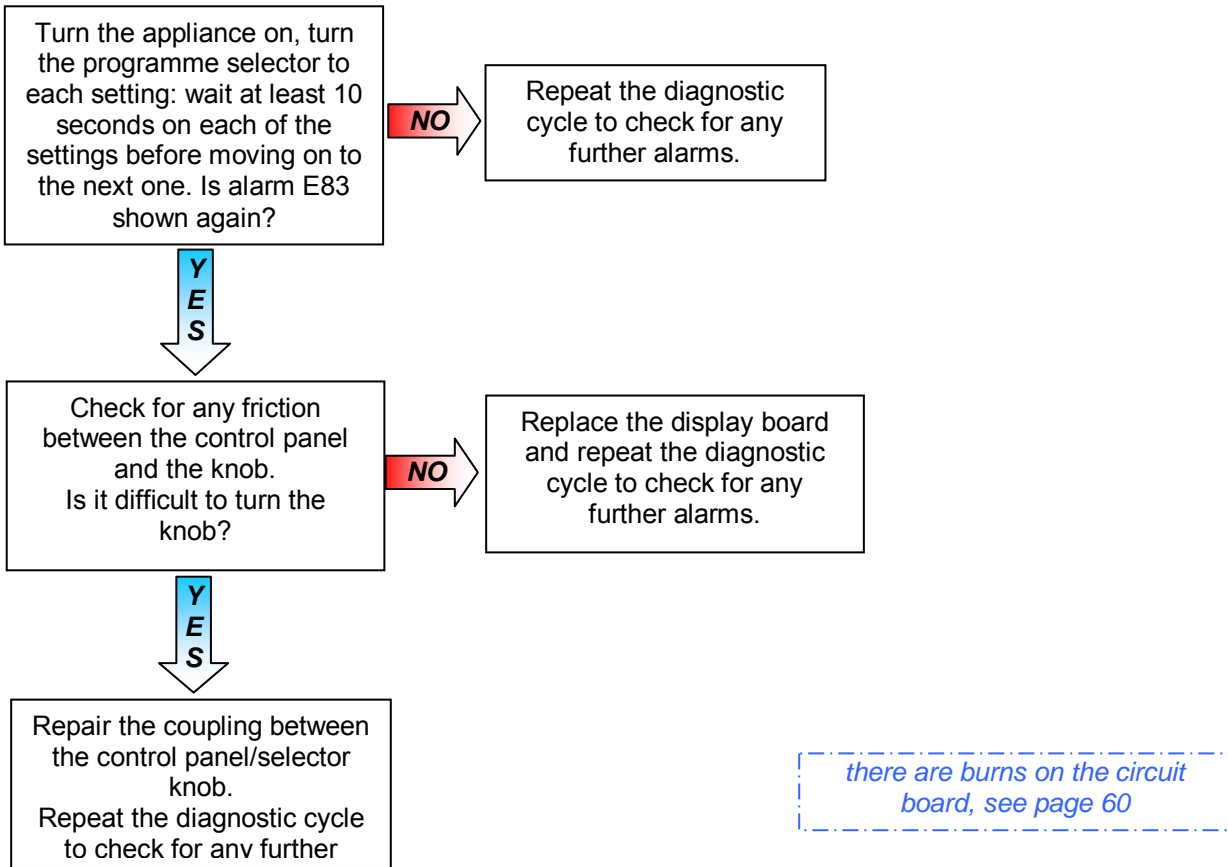

E86	E86: Programme selector configuration error	E86

Checks to perform: Check that all the connectors are inserted correctly

Replace the display board and run the diagnostic cycle to check for any further alarms.

If there are burns on the circuit board, see page 60

E91	E91: Communication error between the display board and the main circuit board	E91
	Incongruence between configuration values on starting the appliance	

Checks to perform: Check that all the connectors are inserted correctly

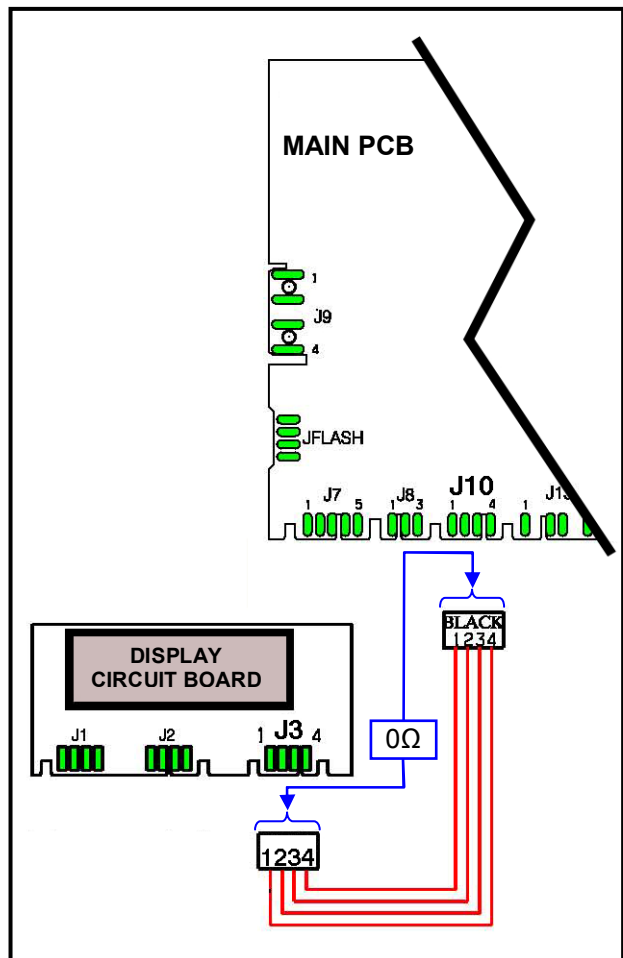
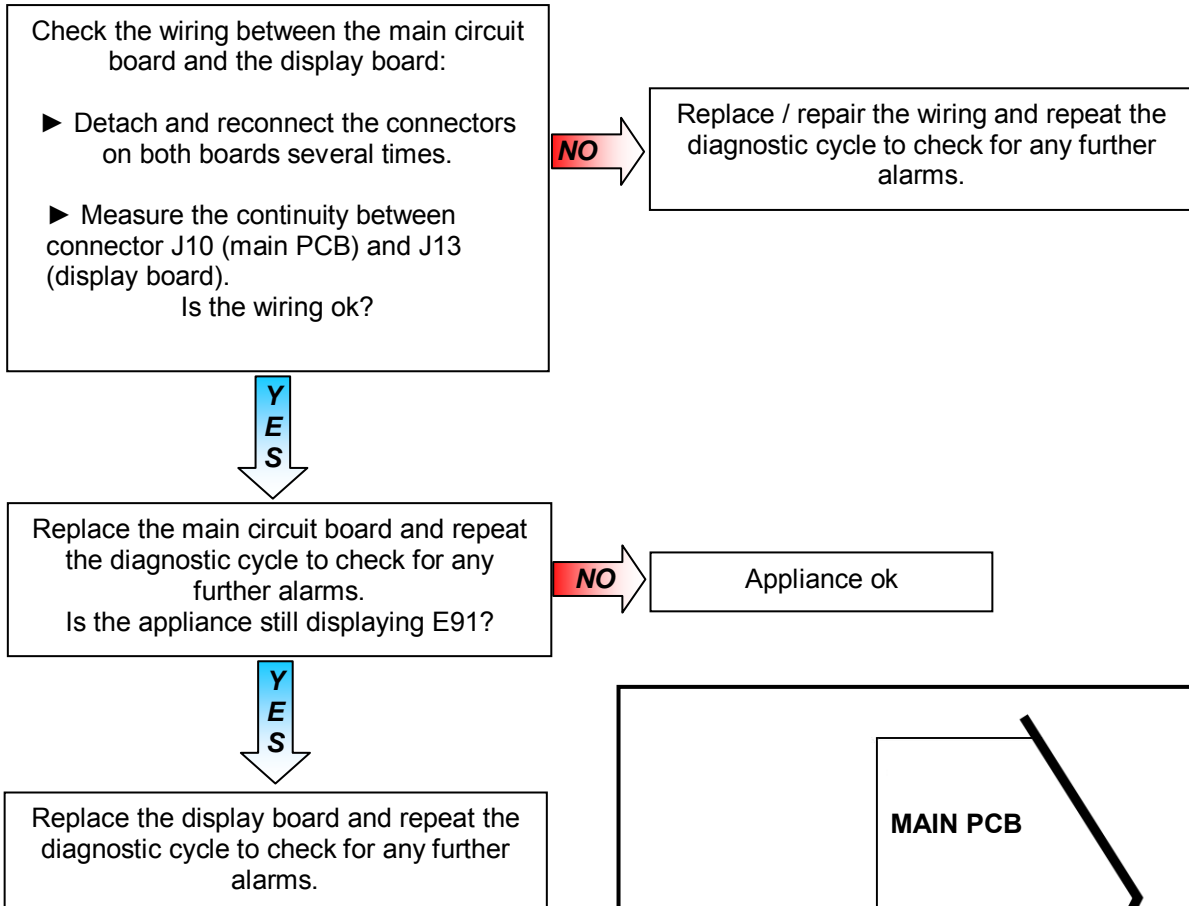

If there are burns on the circuit board, see page 60

E92	E92: protocol incongruence	E92
	Incongruence between configuration values on starting the appliance	

Checks to perform: *Check that all the connectors are inserted correctly*

Possible incorrect configuration.
Replace the circuit board and repeat the diagnostic cycle to check for any further alarms.

E93	E93: Appliance configuration error	E93
	Incongruence between configuration values on starting the appliance	

Checks to perform: *Check that all the connectors are inserted correctly*

Possible incorrect configuration.
Replace the circuit board and repeat the diagnostic cycle to check for any further alarms.

E94	E94: Incorrect configuration of washing cycle	E94
	Incongruence between configuration values on starting the appliance	

Checks to perform: *Check that all the connectors are inserted correctly*

Possible incorrect configuration.
Replace the circuit board and repeat the diagnostic cycle to check for any further alarms.

E97	E97: Incongruence between control selector version and configuration data	E97
	Discrepancy between programme configuration data and selector recognition data	

Checks to perform: *Check that all the connectors are inserted correctly*

Possible incorrect configuration.
Replace the circuit board and repeat the diagnostic cycle to check for any further alarms.

E9C	E9C: Display board configuration error	E9C

Checks to perform: *Check that all the connectors are inserted correctly*

Possible incorrect configuration.
Replace the circuit board and repeat the diagnostic cycle to check for any further alarms.

EC4	EC4: AGS current sensor faulty error	EC4
	Spin speed reduced to safety speed of 150 rpm	

Checks to perform: Check that all the connectors are inserted correctly

Replace the main PCB and run the diagnostic cycle to check for any further alarms.

If there are burns on the circuit board, see page 65

EF1	EF1: Drain hose blocked/kinked/too high; drain filter clogged/dirty	EF1
------------	--	------------

This warning only appears at the end of the cycle. The appliance detected long drainage phases during the cycle. (E.g.: More than 20 seconds when draining after rinses). Check/clean the drain filter.

EF2	EF2: Excessive detergent dosing; drain hose kinked/blocked; drain filter dirty/clogged	EF2
------------	---	------------

This is an excessive detergent dosing warning. The system detected too much foam was forming during the drain phases. Advise the Customer to use the correct quantity of detergent and to make sure the filter and drain circuit are clean.

EF3	EF3: Aqua Control device triggered	EF3
------------	---	------------

This warns about the presence of water at the bottom of the appliance. Check for any water leaks and that the Aqua Control device float is positioned correctly.
It can also be caused by excessive overheating of the drain pump. Check for any items which may obstruct the normal operation of the rotor.

EF5	EF5: Unbalanced load, spin phases skipped.	EF5
------------	---	------------

This is an unbalanced load warning. The appliance detected an extremely unbalanced load during the spin phases. Advise the customer to load more washing into the drum and not just individual garments.

EF6	EF6: Reset appliance.	EF6
------------	------------------------------	------------

No action to be performed, if continues, replace the main PCB

EH1	EH1: Mains frequency incorrect	EH1
	Power supply frequency out of configured range	

Checks to perform: Check that all the connectors are inserted correctly

Important!
The appliance remains in alarm status until the mains frequency returns to the correct values or the appliance is switched off (programme selector set to "0"). Only the family of the alarm is displayed and the diagnostics mode cannot be accessed. The complete alarm can only be read when the situation has normalised.

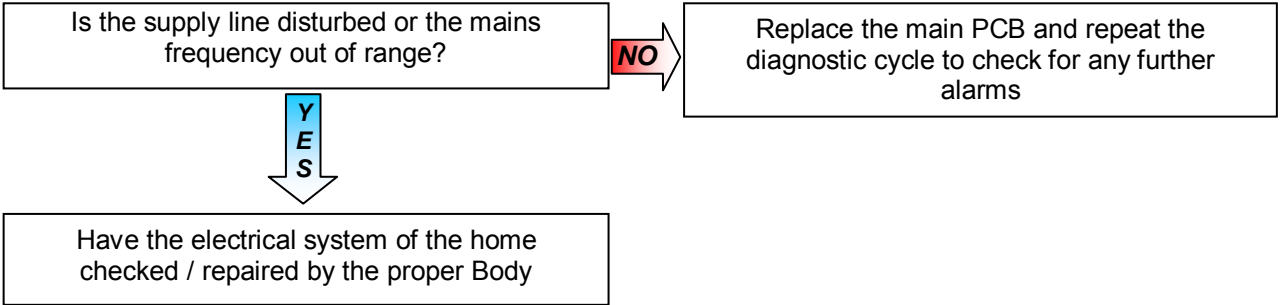

EH2	EH2: Supply voltage too high	EH2
	Value of the supply voltage higher than that configured (for more than 10 seconds)	

Checks to perform: Check that all the connectors are inserted correctly

Important!
The appliance remains in alarm status until the mains voltage returns to the correct values or the appliance is switched off (programme selector set to "0"). Only the family of the alarm is displayed and the diagnostics mode cannot be accessed. The complete alarm can only be read when the situation has normalised.

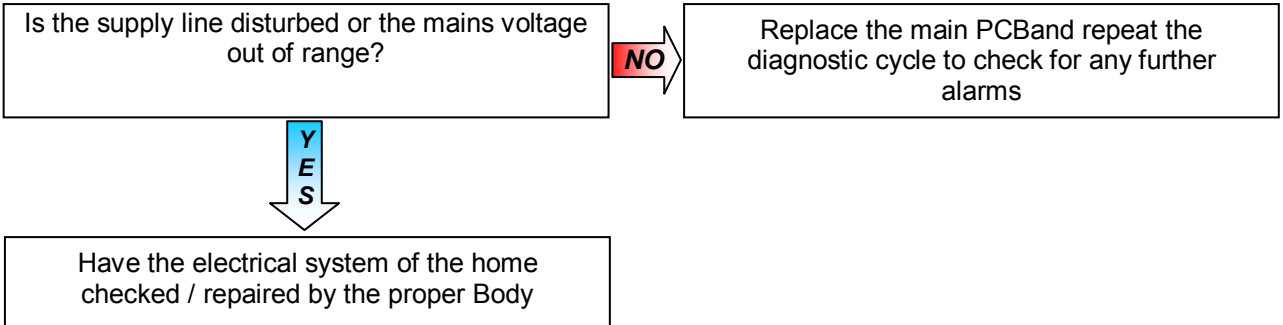

EH3	EH3: Supply voltage too low	EH3
	Value of the supply voltage higher than that configured	

Checks to perform: Check that all the connectors are inserted correctly

Important!
The appliance remains in alarm status until the mains voltage returns to the correct values or the appliance is switched off (programme selector set to "0"). Only the family of the alarm is displayed and the diagnostics mode cannot be accessed. The complete alarm can only be read when the situation has normalised.

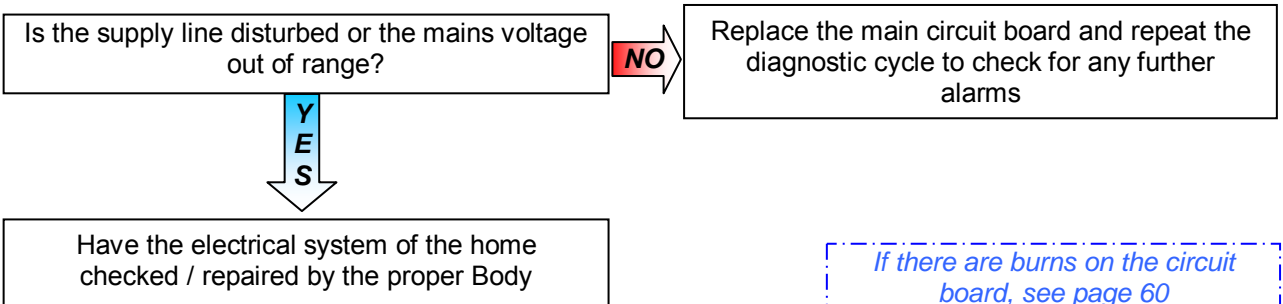

7 OPERATING CIRCUIT DIAGRAM WM WITH AQUA CONTROL

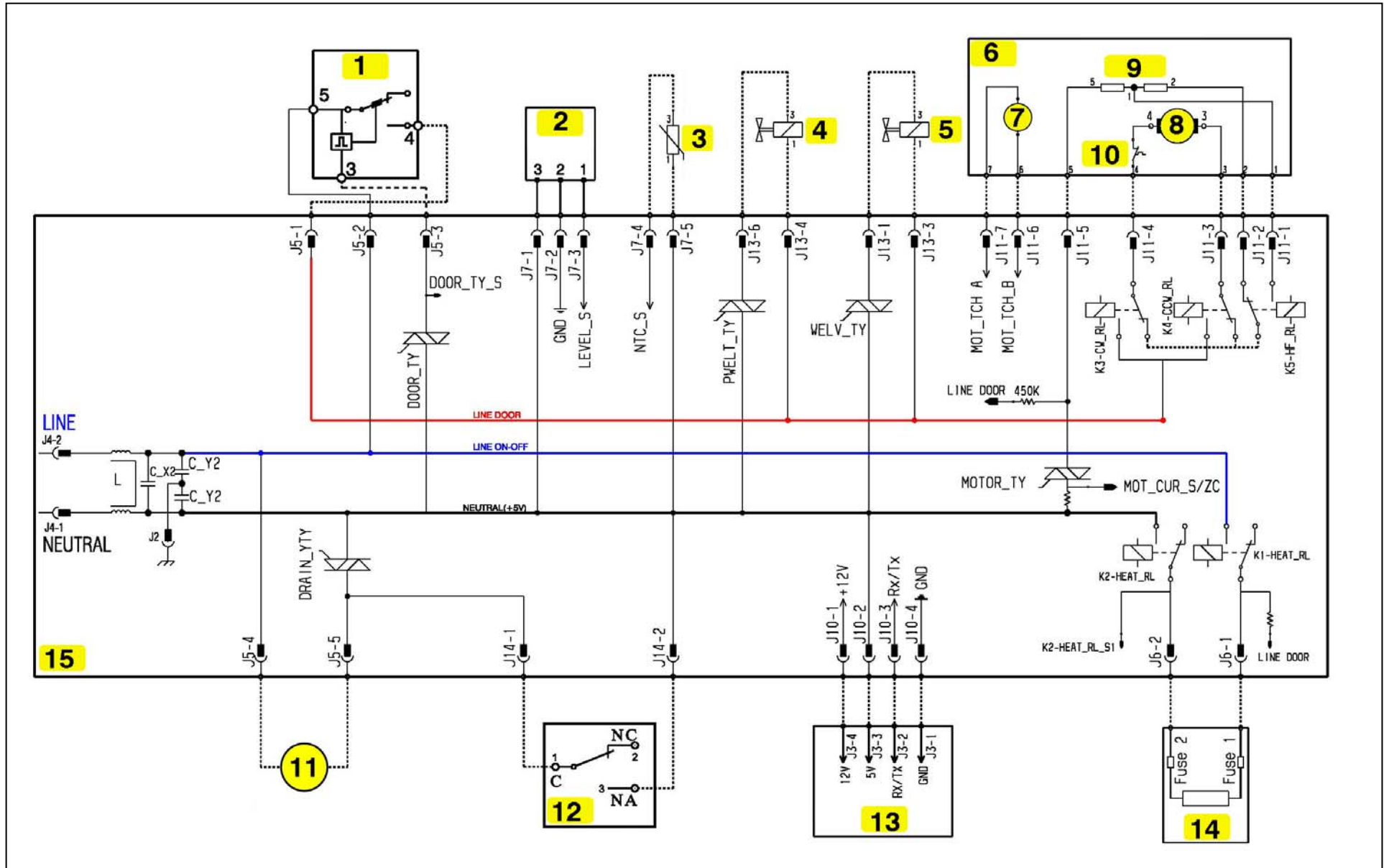

7.1 Key to circuit diagram WM

Appliance electrical components	PCB components		
<ol style="list-style-type: none"> 1. Traditional door lock 2. Analogue pressure switch 3. NTC temperature probe 4. Pre-wash solenoid 5. Wash solenoid 6. Motor with half-field 7. Motor tachometric generator 8. Rotor (motor) 9. Stator (motor) 10. Overheating cut-out (motor) 11. Drain pump 12. Aqua control 13. Display board 14. Heating element (with thermal fuses) 15. Main PCB 	<table style="width: 100%; border: none;"> <tr> <td style="width: 50%; vertical-align: top;"> <p>DOOR_TY DRAIN_YTY PWELWT_TY WELV_TY K1 K2 K3 K4 K5</p> </td> <td style="width: 50%; vertical-align: top;"> <p>Door interlock Triac Drain pump Triac Pre-wash solenoid Triac Wash solenoid Triac Heating element relay (Line) Heating element relay (Neutral) Motor relay: clockwise rotation Motor relay: anti-clockwise rotation Motor relay: half-range power supply (some models)</p> </td> </tr> </table>	<p>DOOR_TY DRAIN_YTY PWELWT_TY WELV_TY K1 K2 K3 K4 K5</p>	<p>Door interlock Triac Drain pump Triac Pre-wash solenoid Triac Wash solenoid Triac Heating element relay (Line) Heating element relay (Neutral) Motor relay: clockwise rotation Motor relay: anti-clockwise rotation Motor relay: half-range power supply (some models)</p>
<p>DOOR_TY DRAIN_YTY PWELWT_TY WELV_TY K1 K2 K3 K4 K5</p>	<p>Door interlock Triac Drain pump Triac Pre-wash solenoid Triac Wash solenoid Triac Heating element relay (Line) Heating element relay (Neutral) Motor relay: clockwise rotation Motor relay: anti-clockwise rotation Motor relay: half-range power supply (some models)</p>		

7.2 Main circuit board connectors

J9	J7
Serial interface: J9-1 ASY_IN J9-2 ASY_OUT J9-3 +5V J9-4 GND	J7-1 Analogue pressure switch (+5V) J7-2 Analogue pressure switch (GND) J7-3 Analogue pressure switch (signal) J7-4 NTC temperature probe J7-5 NTC temperature probe
J10	J13
Communication with display board: J10-1 Vee 12V J10-2 5V J10-3 Rx/Tx J10-4 GND	J13-1 Wash solenoid valve (triac) J13-3 Solenoid valves (line) J13-4 Solenoid valves (line) J13-6 Pre-wash solenoid valves (triac)
J11	J5
J11-1 Motor (stator - half field) J11-2 Motor (stator full field) J11-3 Motor (rotor) J11-4 Motor (rotor) J11-5 Motor (triac) J11-6 Motor (tachometric generator) J11-7 Motor (tachometric generator)	J5-1 Door lock (Sensing Line) J5-2 Door lock (Line) J5-3 Door lock (Triac) J5-4 Drain pump (Line) J5-5 Drain pump (Triac)
J4	J6
U4-1 line (neutral) U4-2 line	J6-1 heating element (Line Relay) J6-2 heating element (Neutral Relay)
J1	
J1 GND	

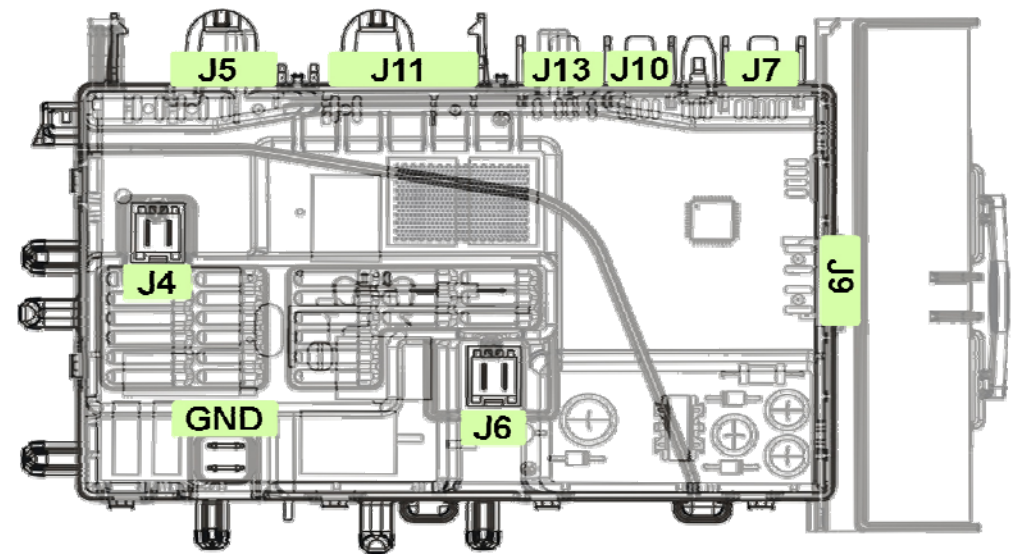

7.3 Burns on the main circuit board EWM0931x

In the event of burns on the main circuit board, check whether the problem was caused by another electrical component (short-circuits, poor insulation, water leaks). Use the figures that follow to pinpoint the component which may have caused the problem, depending on the area of the burns.

The type of board illustrated is the one with the largest number of components; Some boards do not feature all of these components.

