



©Electrolux Home Products Italy S.p.A.

Corso Lino Zanussi, 30  
I - 33080 Porcia – PN -

Fax: + 39 0434 394096

SOI

Edition: 03-2008 Rev 0.0

Publication  
number

**599 72 66-60**

EN

**Condensation tumble  
dryer with rotating  
compressor**

**ENV06 AEG HP**



# CONTENTS

1	Introduction.....	4
1.1	Installation.....	4
2	Technical characteristics .....	5
2.1	Technical data .....	5
2.2	Circuit board .....	5
3	Control panel .....	6
3.1	Styling .....	6
3.2	Programme selector .....	6
3.3	Buttons.....	6
3.4	Symbols on the LCD.....	7
3.5	Drying level.....	8
3.6	Spin setting.....	8
3.7	Long anti-crease.....	9
3.8	Disabling or enabling the buzzer momentarily .....	9
3.8.1	Disabling or enabling the buzzer permanently.....	9
3.9	Time-controlled programme .....	10
3.10	Delayed start button .....	10
3.11	Start / Pause button.....	10
3.12	Child safety lock .....	11
3.13	Deleting the TANK FULL alarm permanently.....	11
3.14	Adjusting conductivity.....	12
3.14.1	Indications displayed.....	12
3.15	Cycle end alarms.....	13
4	How to operate the appliance.....	14
4.1	How a cycle works.....	14
4.2	Operation in PAUSE mode.....	14
4.3	Power failure.....	15
5	Construction .....	16
5.1	The principle of the heat pump in the drying circuit.....	16
5.2	Components .....	18
5.3	Drum .....	19
5.4	Air seal and drum pin support.....	19
5.5	Water circuit.....	20
5.6	Drum rotation principle .....	20
6	Electrical components .....	21
6.1	Electronic control .....	21
6.2	Main circuit board functions.....	22
6.3	Electronic control memory: general structure.....	23
6.4	Conductivity sensor .....	24
6.5	Terminal board with integrated anti-disturbance filter .....	24
6.6	Compressor .....	25
6.7	Heat protection .....	25
6.8	Compressor motor capacitor .....	25
6.9	Compressor cooling fan.....	26
6.10	Drum motor .....	26
6.11	Drum motor capacitor.....	26
6.12	Tank loading pump.....	27
6.13	Process power fan.....	27
6.14	Power fan capacitor.....	27
6.15	NTC probe.....	28
6.16	Door switch.....	28
6.17	Door lock .....	28
7	Wiring diagram .....	29
8	Diagnostics system.....	30
8.1	Accessing diagnostics .....	30

8.2	Quitting the diagnostics system.....	30
9	Alarms .....	35
9.1	Displaying the alarms to the user .....	35
9.2	Viewing alarms during normal operation .....	35
9.3	Reading the alarms.....	35
9.3.1	Viewing any other alarms.....	36
9.3.2	Deleting the last alarm .....	36
9.3.3	Notes on the behaviour of certain alarms .....	36
9.4	Alarm Summary Table .....	37
10	Troubleshooting .....	42
10.1	The diagnostics programme cannot be accessed .....	42
10.2	The LEDs do not light up after the buttons are pressed .....	43
10.3	The drying cycle is long and the washing is still damp. ....	44
11	Accessing components.....	45
11.1	door .....	45
11.2	Fluff filters .....	45
11.2.1	Door fluff filter.....	45
11.2.2	Lower fluff filter.....	45
11.2.3	Evaporator fluff filters .....	46
11.2.4	Evaporator water fluff filter .....	46
11.3	Compressor fan motor.....	47
11.4	Door lock .....	47
11.5	Door micro-switch.....	47
11.6	Door fastening latch and door micro-switch latch .....	48
11.7	Drum lamp.....	48
11.8	Tank.....	48
11.9	Worktop.....	49
11.10	Control support and control panel assembly.....	49
11.11	Main circuit board.....	50
11.11.1	Removing the board .....	50
11.11.2	Removing the selector pin .....	50
11.11.3	Removing the selector dial .....	50
11.11.4	Buttons spring.....	50
11.12	Sides.....	51
11.13	Water conduits .....	51
11.14	Condensation pump / float switch .....	52
11.14.1	Pump .....	52
11.14.2	Float micro-switch.....	52
11.15	Drum rotation motor .....	53
11.16	Heat pump circuit NTC .....	54
11.17	Conductivity circuit brushes .....	55
11.17.1	Drum brush.....	55
11.17.2	Rear brush.....	55
11.18	Rear air channel .....	56
11.19	Motor protector .....	57
11.20	Removing the chassis for servicing.....	58
11.21	Air conduit .....	59
11.22	Front air seal .....	59
11.23	Conduit rollers .....	59
11.24	Rear air seal .....	60
11.25	Checking the heat pump performance .....	61
11.26	Servicing the heat pump circuit.....	62
11.26.1	Compressor replacement .....	62
11.26.2	Filling .....	62
11.27	Door reversibility.....	63

# 1 Introduction

Purpose of this manual

The purpose of this manual is to provide technicians (who already have the basic skills required to carry out repairs on tumble dryers) with technical information on this condensation tumble dryer with electronic control. The electronic control is made up of a main circuit board with integrated selector - certain models have an LCD display. They are supplied ready-assembled and tested by the manufacturer.

The manual deals with the following topics:

- Technical characteristics
- Control panel
- Description of operation
- Construction
- Electrical components and wiring diagram
- Guide to diagnostics
- Alarms
- Access

Warnings

	Any work on electrical appliances must only be carried out by qualified technicians. Unplug the appliance before accessing internal components.
-----------------------------------------------------------------------------------	-------------------------------------------------------------------------------------------------------------------------------------------------

## 1.1 Installation

The appliance must be installed so that it is perfectly level (using a spirit level), to allow for the correct flow of condensation water into the purpose-provided tank.

The feet must never be removed. A gap must always be left between the bottom of the tumble dryer and the floor to prevent the appliance from overheating.

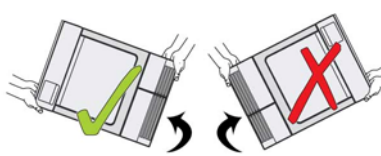

	If the appliance has to be placed on its side for maintenance or another reason, lie it on its left side. When you replace it in its vertical position, wait for two hours before switching it on so that the oil inside the compressor can flow away completely. Otherwise the compressor could incur some serious damage.
-------------------------------------------------------------------------------------	-----------------------------------------------------------------------------------------------------------------------------------------------------------------------------------------------------------------------------------------------------------------------------------------------------------------------------

## 2 Technical characteristics

### 2.1 Technical data

Dimensions of appliance	Height: 85 cm Width: 60 cm Depth: 58 cm
Supply voltage	Volts: 220-240 Hz: 50/60
No. buttons	7
No. LEDs	1 on models with large LCD
Type of display	LCD
Buzzer	buzzer integrated in the circuit board
Serial port	DAAS-EAP communication protocol up to 230400 baud
Programme selector	21 positions with integrated ON/OFF switch
Drying system	damp condensation with heat exchanger
Humidity control	conductivity sensor
Motor	capacitor-run asynchronous monophas motor
Heating unit	Heat pump
Heat pump gas	R134a 300g
Temperature control	NTC probe
Tank capacity	Condensation tank approx. 4 l
Tank loading pump	with asynchronous motor

### 2.2 Circuit board

The electronic control is made up of a main circuit board with integrated selector and on certain models LCD display, which are supplied ready-assembled and tested by the manufacturer.

The pictures of the boards may differ slightly from those actually fitted on the appliance.



### 3 Control panel

#### 3.1 Styling

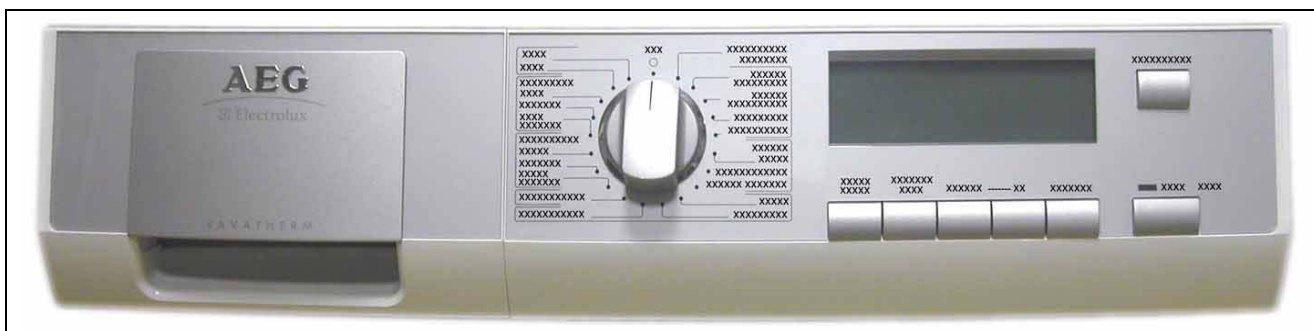

#### 3.2 Programme selector

The selector dial has 15 positions on models with a small LCD (TC3) and 21 positions on models with a large LCD (TC2).

All models have an integrated ON/OFF switch and are an integral part of the board.

The symbols represent the various drying options for the various fabric types COTTON, SYNTHETIC, SILK and WOOL.

All positions can be configured, depending on the model.



#### 3.3 Buttons





1. Configurable button
2. Configurable button
3. Configurable button
4. Configurable button
5. Configurable button









6. Start / Pause button
7. Delay start button
8. LCD
9. Programme selector

### 3.4 Symbols on the LCD





#### Cycle options icon

	Final humidity level		Fabric spin speed
	Long anti-crease cycle		



#### Cycle icon

	Ready-to-iron		Wardrobe dry
	Light drying		Heavy drying
	Extra strong drying		Drying phase
	Cooling phase		Anti-crease phase

#### Alarms

	Empty out the water collection tank		Clean the filters
	Clean the heat exchanger		Child Lock
	Buzzer		

#### Timer

	Delayed start		Time remaining / Alarm code
-------------------------------------------------------------------------------------	---------------	-------------------------------------------------------------------------------------	-----------------------------



### 3.5 Drying level

Press the button indicated in the figure to adjust the final drying level.



One bar - minimum drying.



Two bars - medium drying.



Three bars - maximum drying.



No bars - drying is automatic.

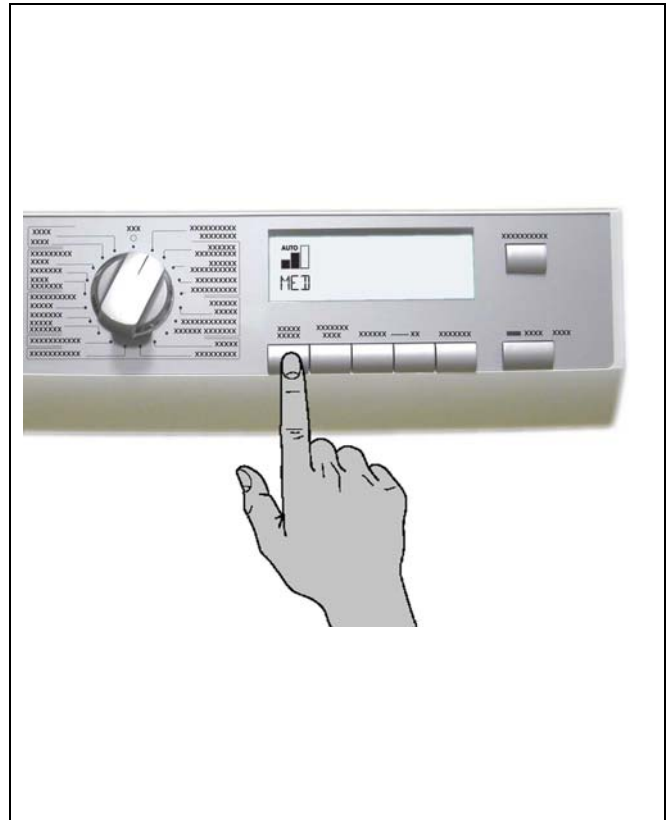

### 3.6 Spin setting

Select this option to modify the drying time.

The tumble dryer takes into account the speed of the washing machine spin cycle. The values vary from a minimum of 800 rpm to a maximum of 1,800 rpm (depending on the chosen programme) in 200 rpm steps.



Minimum spin speed 800 rpm.



Maximum spin speed 1800 rpm.

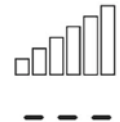

Automatic speed setting.

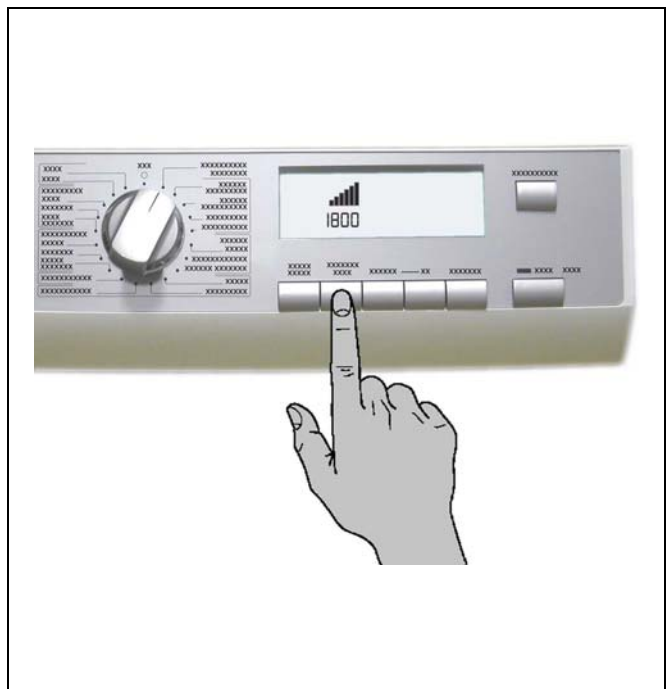

### 3.7 Long anti-crease

This option extends the normal anti-crease time (30 min.) at the end of the drying time by a further 60 minutes.

During this phase the drum turns at intervals. This ensures that the washing remains soft and free from creases.

This phase lasts for a total of 90 minutes.

The washing can be removed from the drum at any time during the anti-crease phase.

When this option is enabled, the corresponding icon is lit.

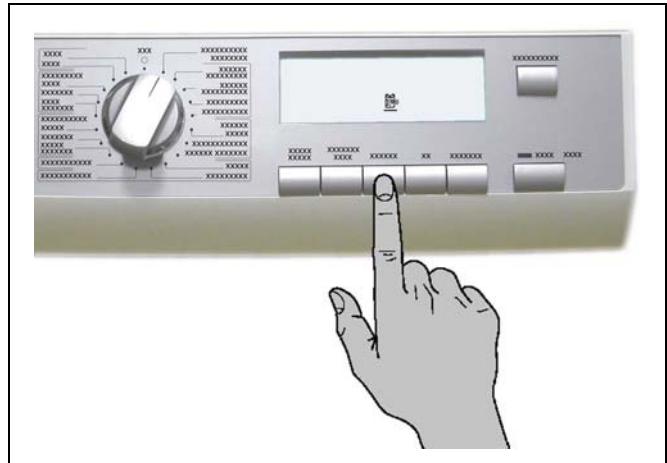

### 3.8 Disabling or enabling the buzzer momentarily

Option to be selected when the tumble dryer is in selection status (set-up).

Press this button to enable the buzzer: enabling is indicated by the icon lighting up.

To disable this option, press the button again.

Even if the buzzer is disabled, an alarm will still sound.

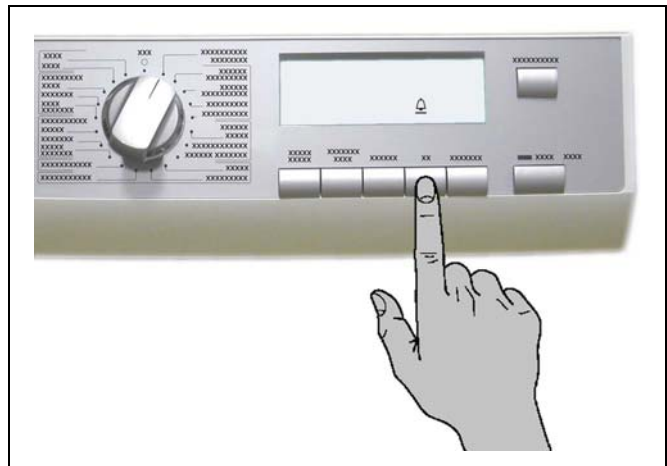

#### 3.8.1 Disabling or enabling the buzzer permanently

If this option is selected, the buzzer will remain disabled or enabled for subsequent cycles too.

Press buttons 1 and 2 simultaneously for 5 seconds. The icon representing the buzzer will be disabled and a beep will sound.

To restore the buzzer, press the same combination of buttons until the buzzer emits a beep.

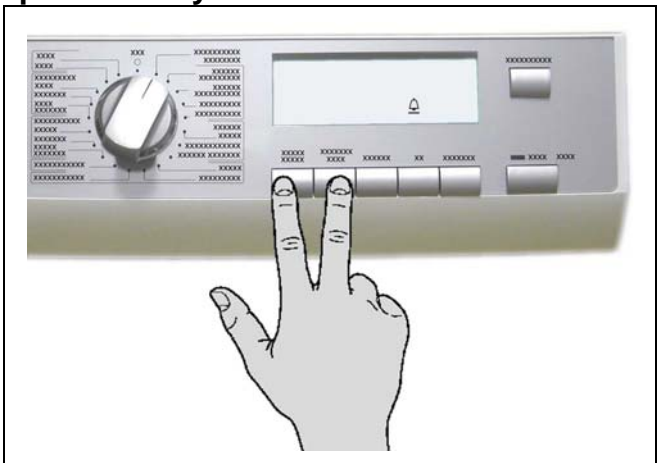

### 3.9 Time-controlled programme

Select the time-controlled programme to set a customised drying cycle irrespective of the level of humidity of the washing.

The time changes in 10-minute steps, up to a maximum of 3 hours.

If no choice is made, the programme will last 10 minutes.

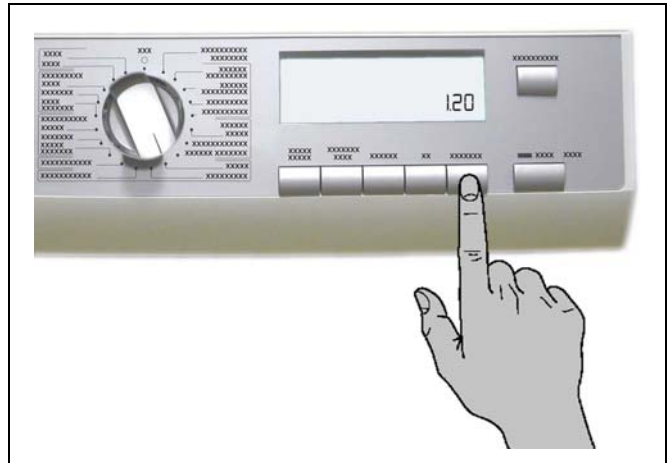

### 3.10 Delayed start button

If you press this button before the START button is pressed, a delayed start can be selected.

The time varies up to a maximum of 20 hours. It is shown on the Display.

The delay increases each time the button is pressed:

For the first two hours, the time increases by half an hour. After two hours, it increases by an hour at a time.

To reset the delay time, move the selector dial one or more positions or press the button until the Display shows 0.00.

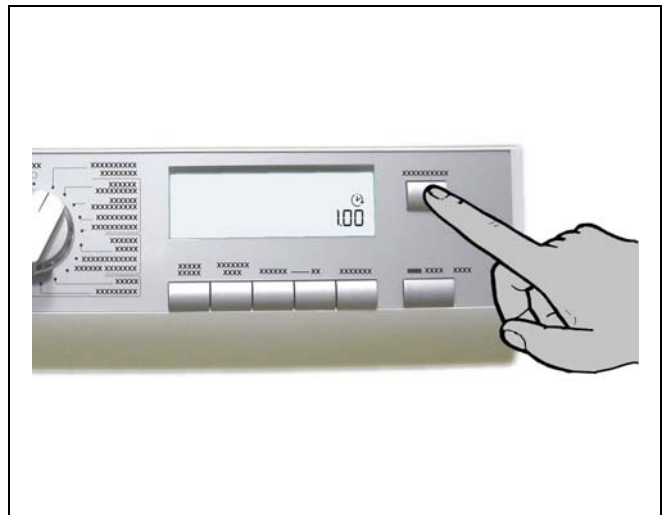

### 3.11 Start / Pause button

- Start

When a drying programme is selected on the dial, the icons for the operating phases (drying, cooling, anti-crease) light up and the START/PAUSE LED flashes.

Once any options have been selected, press this button to start the cycle. The relevant LED and the icon for the phase in progress will remain lit.

- Pause

If a drying cycle is under way, press the START/PAUSE button and the tumble dryer will suspend the cycle under way and go into PAUSE mode; the relevant LED flashes.

When you press the START/PAUSE button again, the drying cycle will recommence from the point at which it stopped.

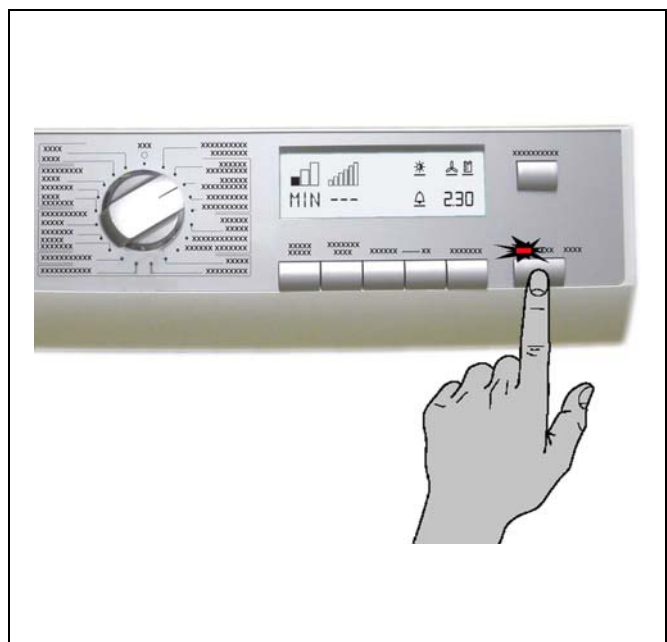

### 3.12 Child safety lock

To prevent a programme from being started or changed by accident, it is possible to set a child lock.

This function enables all buttons and the programme dial to be locked.

To enable or disable this function, press the EXTRA ANTI-CREASE and BUZZER buttons simultaneously for 5 seconds.

- Before starting the programme: the appliance cannot be used.
- After the programme has started: the selected programme cannot be changed.

The display shows the symbol  indicating that the child lock has been enabled.

The child lock device does not deactivate at the end of the programme.

In order to start a new programme you must first deactivate the child lock.

To disable this protection, press the above two buttons again.

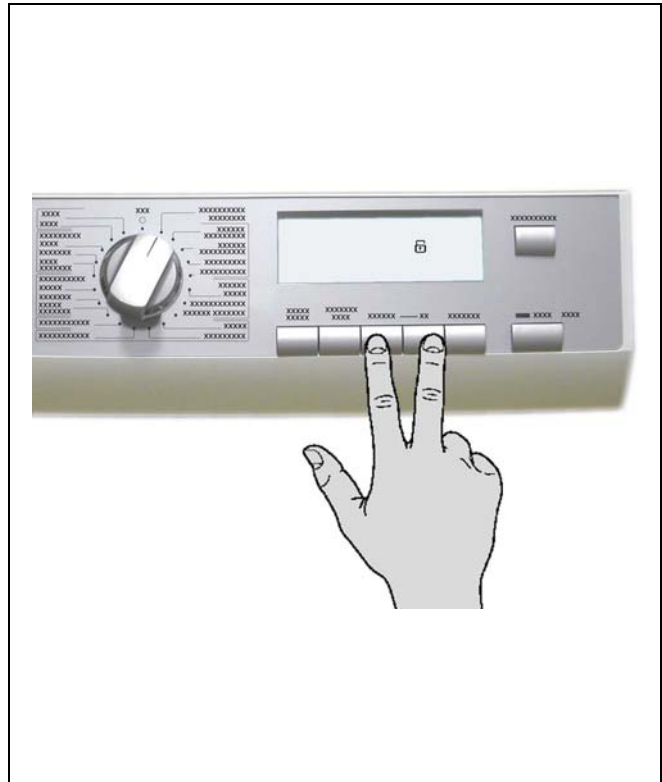



### 3.13 Deleting the TANK FULL alarm permanently

In appliances fitted with the automatic water drain kit, the  TANK FULL alarm can be deleted permanently.

1. Turn the programme selector to any programme.
2. Press the drying level and spin load (U/Min) buttons simultaneously for approximately 5 seconds.

The current setting is displayed:

- the symbol  indicates that the warning message is disabled.
- The symbol  indicates that the warning message is enabled.

On delivery of the appliance, the alarm message is enabled.

This alarm appears at the end of every drying cycle, or, during normal cycles if the condensation water tank is full.

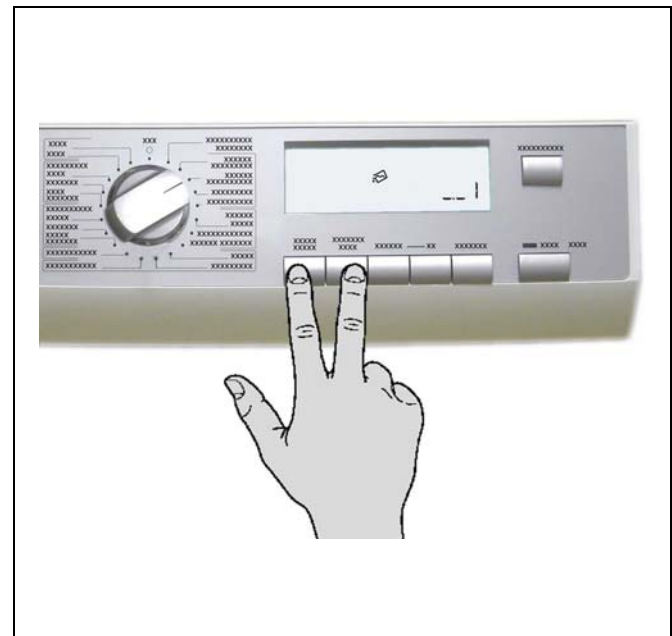

### 3.14 Adjusting conductivity

The "conductivity" of the water used for washing varies from area to area: the conductivity sensor is set to a standard value; significant variations in conductivity level may have a negative effect on the final results of drying (washing that is too dry or still damp).

These variations can be noted particularly in "slightly damp" and "ready-to-iron" cycles; "wardrobe dry" cycles are practically never influenced by changes in conductivity.

#### To modify this setting:

1. turn the appliance on by turning the programme selector to any position.
2. Press the Drying level and TIME-CONTROLLED DRYING buttons simultaneously for approximately 5 seconds. The current setting is displayed.

To modify the conductivity value, press the start/pause button. The conductivity level changes and is indicated by the lighting up of the horizontal segments in the last digit.

#### To store this setting:

Press the above buttons simultaneously until the buzzer sounds (about 5 seconds).

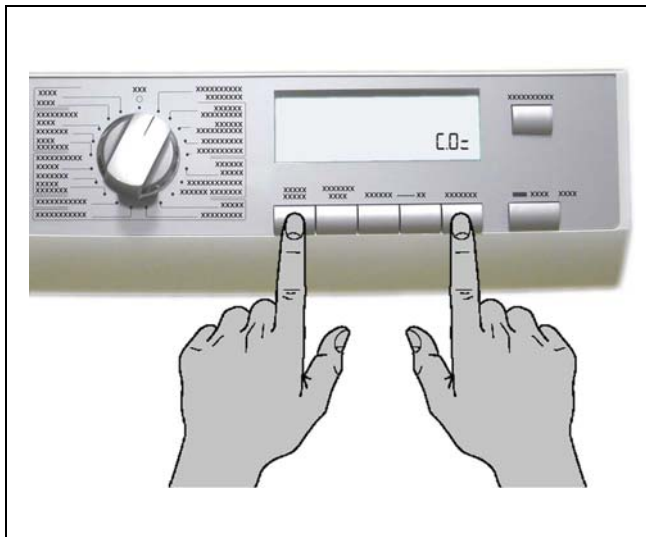

#### 3.14.1 Indications displayed

Display	Conductivity level	Approximate value (µS/cm)
C.O. _	LOW	< 300
C.O. =	MEDIUM	300 – 600
C.O. E	HIGH	> 600

The normal factory setting is medium level, but some models may have a different configuration.

Ask your local water supplier for details of the conductivity level of your water supply.

### 3.15 Cycle end alarms



#### Clean the heat exchanger:

It lights up after 5 drying cycles to remind the user to clean the filters at the bottom and the heat exchanger.



#### Clean Filter

It lights up at the end of every cycle to advise the user to clean the fluff filter on the door and on the filler opening.



#### Tank full

It lights up during the drying cycle if the electronic circuit has detected the closure of the float micro-switch or at the end of the cycle to advise the user to empty the tank.

#### Start / Pause button LED

It flashes green when the cycle is on pause; it lights up green without flashing when the cycle is running regularly. If an alarm is present, three beeps will sound, and will be repeated after a few seconds. The red LED will flash.



## 4 How to operate the appliance

When the selector is moved from the OFF position to a drying programme, the icons or LEDs for the drying phases light up and the START/PAUSE LED flashes.

The various options can be selected during this phase and the relevant icon will light up.

The Display shows the maximum drying cycle time.

If the user has selected an option that is not compatible with the chosen programme, the Buzzer sounds and the Display shows Err while the LEDs flash.

When one or more options are selected, the Display shows an increase or a decrease in the amount of time. If the position of the selector is changed after the options have been selected, but before the START/PAUSE button has been pressed, the options will be reset.

### 4.1 How a cycle works

A drying cycle starts after a drying programme has been chosen using the selector, any options (where necessary) have been selected, and the START/PAUSE button has been pressed.

The LED for the START/PAUSE button will remain lit and at the same time the icon relating to the phase in progress will light up, while the Display will show the maximum drying time.

A drying cycle is made up of the phases described below.

- DRYING

If the cycle is automatic, the duration is obtained from the time used to remove humidity, up to the final degree of humidity characterising the cycle.

If the cycle is time-controlled, the duration will depend on the time set.

- COOLING

This has a maximum duration of 10 minutes for timed cycles, whereas for automatic ones it may be less, according to the temperature inside the drum.

- ANTI-CREASE

This has a duration of 30 minutes.

The programme cannot be changed after the drying programme has started.

If the position of the selector is changed, the START/PAUSE button LED will start flashing and the buzzer will indicate that this operation is not possible, and the Display will show the message Err.

If any of the buttons are pressed, the START/PAUSE button LED will start flashing and the buzzer will indicate that this operation is not possible, and the Display will show the message Err.

The options allowed for each cycle can only be entered after a drying programme has been selected and the selector is positioned at the start of the cycle, or during a cycle after first pressing the START/PAUSE button. To reset a drying cycle the selector must be turned to the OFF position.

### 4.2 Operation in PAUSE mode

If a drying cycle is running, when the START/PAUSE button is pressed the tumble dryer stops the cycle in progress and the START / PAUSE button LED flashes. In models featuring a display panel, the time remaining until the end of the cycle is displayed.

If the selector dial is turned, the buzzer will sound to indicate this operation is not allowed.

In this status, only certain options can be changed. Please see the OPTIONS table in the instruction booklet.

If you press the button for an option that is not allowed in the current programme, the buzzer will sound to indicate that the operation is not allowed. The display will show the message Err.

When you press the START/PAUSE button again, the drying cycle will recommence from the point at which it stopped.

### 4.3 Power failure

The following table shows how the tumble dryer reacts in the event of a power failure during a drying cycle.

Before the power failure	After the power failure
Selection (set-up)	Selection (set-up)
Drying cycle	Pause
Cycle paused	Pause
Anti-crease cycle	End of cycle
Delay start cycle	Delay start cycle paused
Delay start cycle paused	Delay start cycle paused
End of cycle	End of cycle
Tank full alarm	Tank full alarm



## 5 Construction

### 5.1 The principle of the heat pump in the drying circuit

The cycle of the tumble dryer heat pump consists in evaporating, compressing, condensing and expanding the refrigerant R134a (fill quantity 270 g).

The refrigerant is located in the steamer (4) and is initially in the liquid state, while the temperature of the moist air arriving from the drum (14) is higher than the boiling point of the coolant. In these circumstances, there is a heat transfer from the heat source to the refrigerant, allowing the latter to evaporate. Due to this cooling, the moisture contained in the air condenses and flows into the collection tray (13), and is then pumped into the condensation tank (15).

The compressor (9) continuously suctions the refrigerant steam, which is compressed repeatedly and then heated. The fluid transfers heat to the capacitor (3). The latter thus re-heats the air suctioned through the fan (2), air which is now dry, and which is conveyed along the drum again, absorbing moisture.

The refrigerant fluid, which is now a liquid again, loses pressure and temperature through the capillary tube (7), enough for the evaporator (13) to absorb heat again from the moist air coming from the drum (14). The equilibrium of the entire system is achieved through the intervention of the NTC situated on the capacitor outlet, which activates the compressor cooling fan (10) through the circuit board. This cycle is repeated incessantly in a closed loop.

If the collection tray (13) contains water, the micro switch intervenes and activates the condensation pump (12), which conveys the water to the tank (15). If it is full, the water that spills out ends up in the tank and is conveyed back to the collection tray (13) along a flexible hose (not shown in the diagram). This moves the float up and activates the micro switch again. The circuit board recognises according to the time (the pump needs between 15 and 40 seconds to empty the trap) whether the trap has been emptied or whether there is water spilling out of the tank, in which case the electronic control shuts off the power supply to the appliance and lights the LED indicating the tank full alarm.

1. Fan
2. Capacitor
3. Steamer
4. Capillary tube
10. Compressor
11. Condensation pump
12. Collection tray
13. Drum
14. Condensation tank

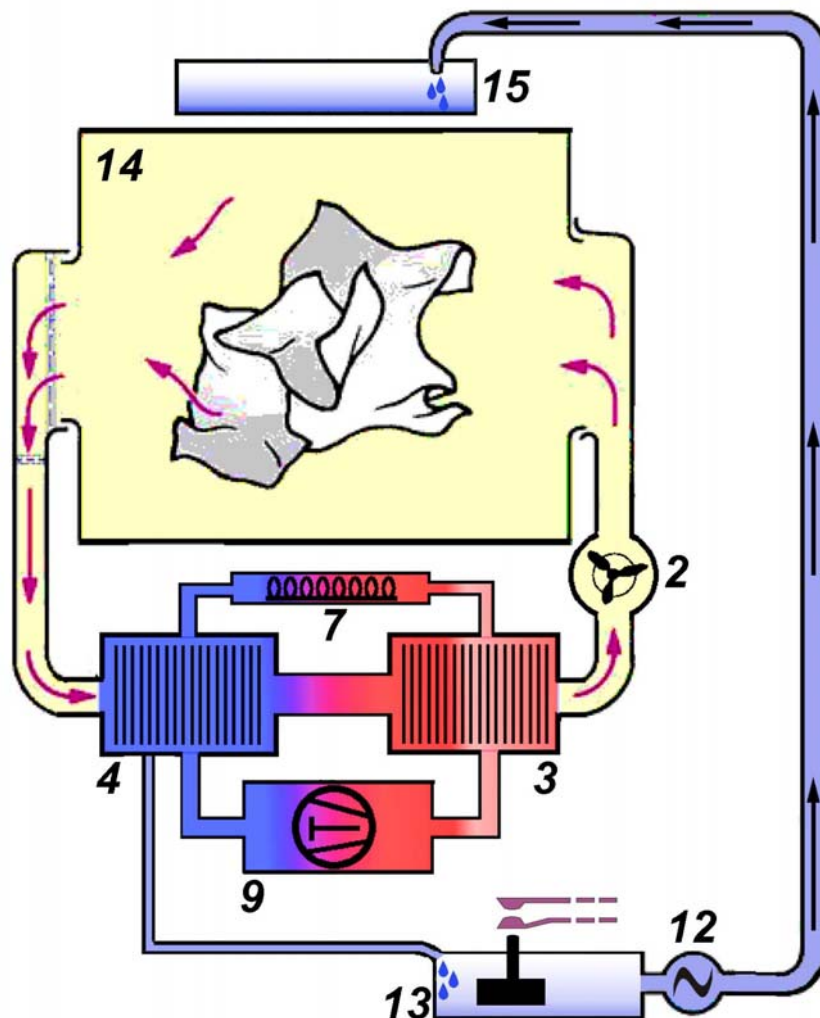

1. Drying dry air
2. Air recirculation power fan
3. Capacitor
4. Steamer
5. Fluff filter
6. Moist air
7. Capillary tube
8. Cold dry air
9. Compressor
10. Compressor cooling fan
11. Drum rotation motor
12. Condensation pump
13. Water collection tray
14. NTC
15. Float micro-switch.

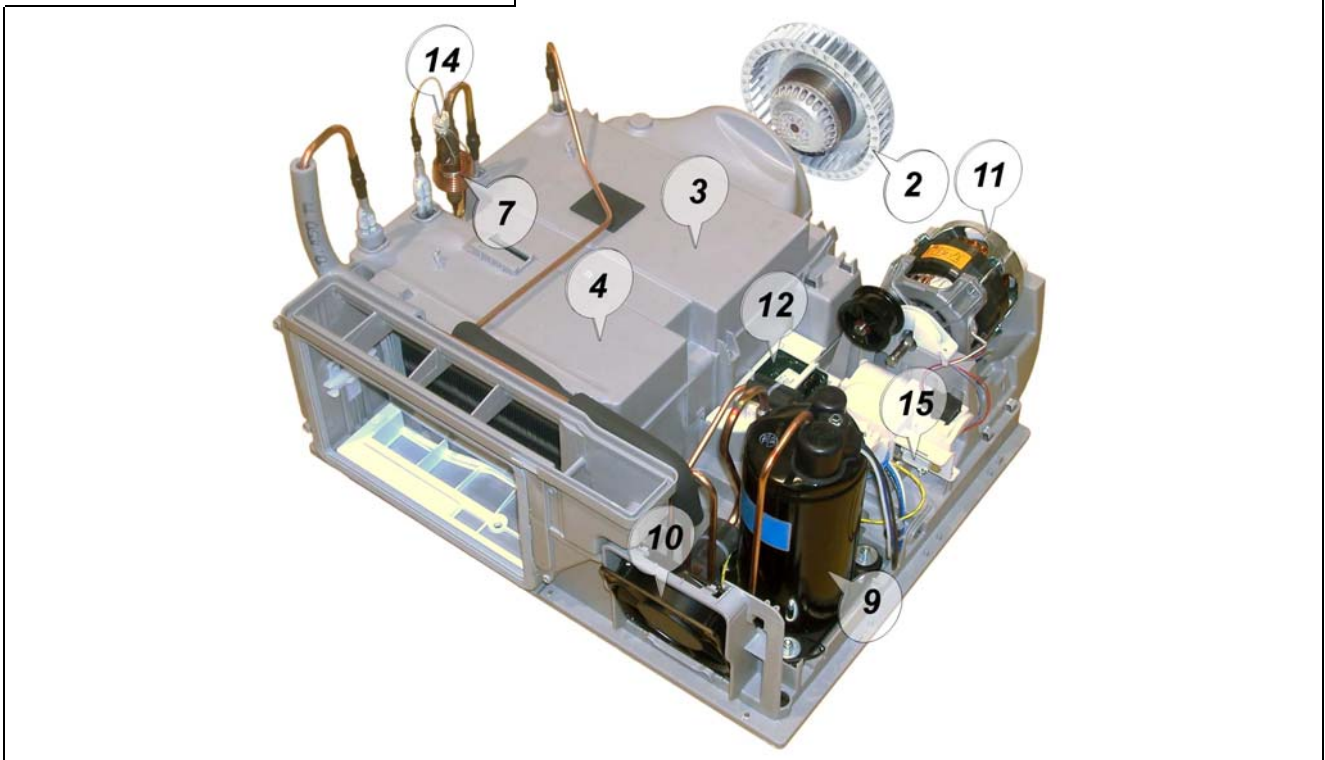
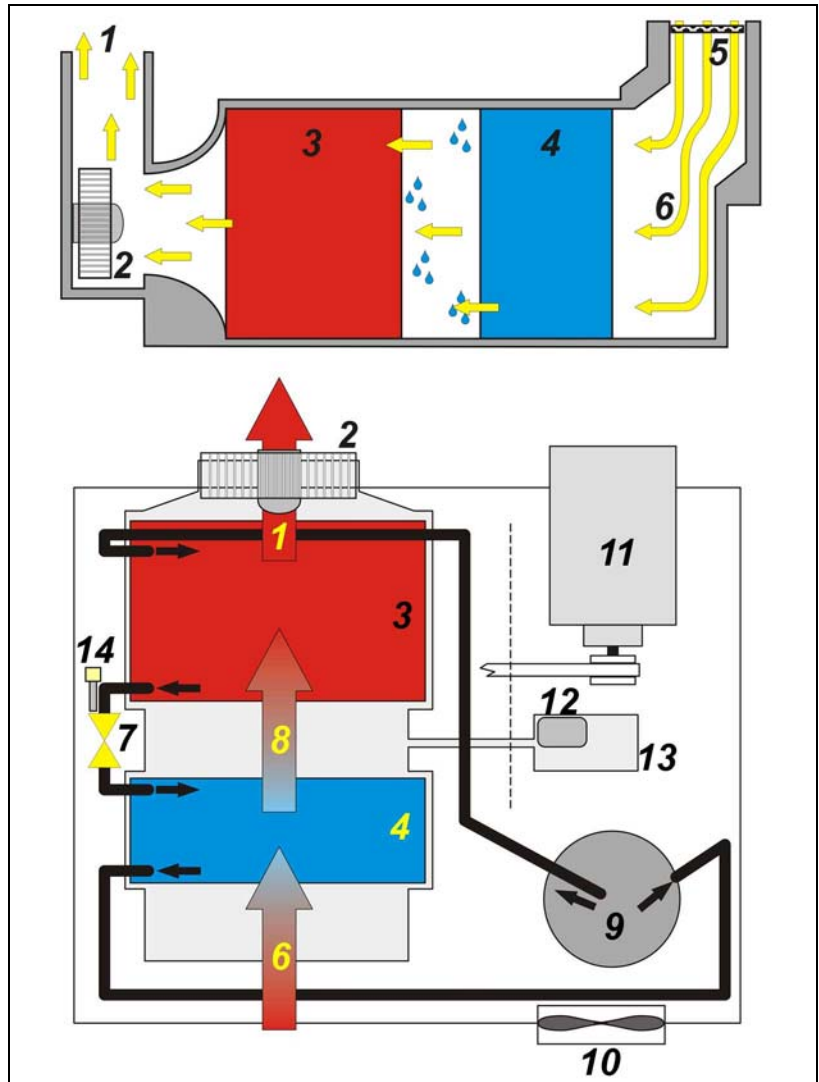

## 5.2 Components

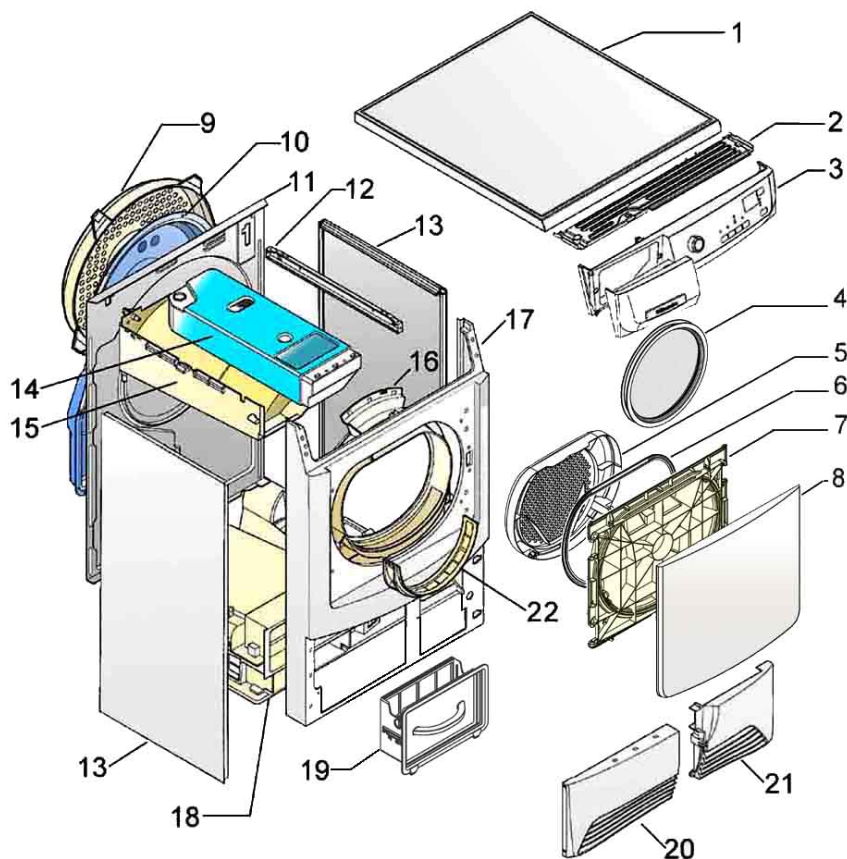

- |                           |                        |
|---------------------------|------------------------|
| 1. Worktop                | 12. Crossbar           |
| 2. Support for controls   | 13. Sides              |
| 3. Control panel          | 14. high tank          |
| 4. Fluff filter           | 15. Tank support       |
| 5. Fluff filter support   | 16. Conduit            |
| 6. Door seal              | 17. Front              |
| 7. Internal door frame    | 18. Base               |
| 8. External door frame    | 19. Fluff filter       |
| 9. Back panel cover guard | 20. Hatch              |
| 10. Back panel cover      | 21. Kick plate         |
| 11. Back panel            | 22. Front fluff filter |

The front and sides are made of painted sheet metal, whereas the back is in zinc-coated sheet metal. These parts are fastened using self-tapping screws and are connected to the base. The shaped base, in carboran, supports all the main elements.

### 5.3 Drum

The drum is made up of two flanges, one front (1), one rear (2), a drum casing (3) and 3 blades (4) which move the washing around during drum rotation.

There is an insulation strip (5) more or less in the centre, above which the contact strip is positioned (6) and which, together with the blades, constitutes the humidity control system.

1. Front flange
2. Rear flange
3. Drum casing
4. Blades
5. Insulation strip
6. Brush contact strip

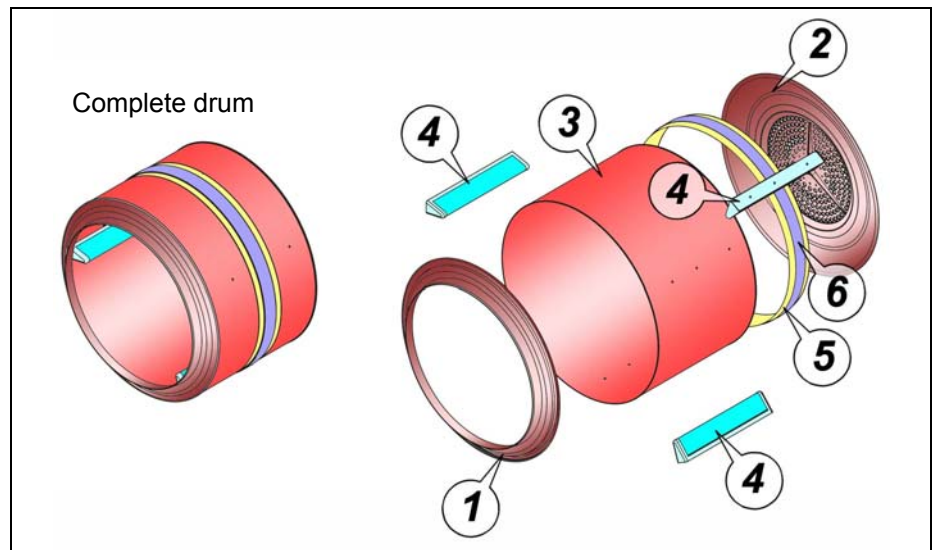

### 5.4 Air seal and drum pin support

#### Rear air seal

1. Rear gasket (fixed to the back panel)
2. Drum
3. Back panel

#### Rear drum support

4. Antifriction washer
5. Fixing ring (Benzing)
6. Back panel
7. Drum pin
8. Support with bushing (fixed to the back panel)

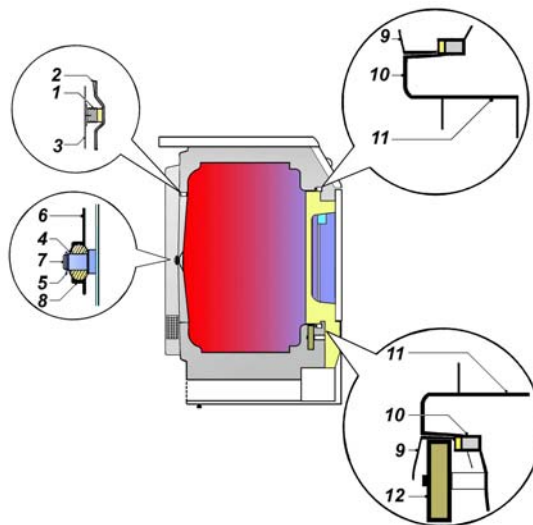

#### Front drum support and air seal

9. Drum
10. Felt washer with tubular support
11. Conduit

#### Bottom drum support

9. Drum
10. Felt washer with tubular support
11. Conduit
12. Support roller for drum movement

## 5.5 Water circuit

1. Water overflow drain tube (transparent)
2. Tank water fill tube (red)
3. Pump

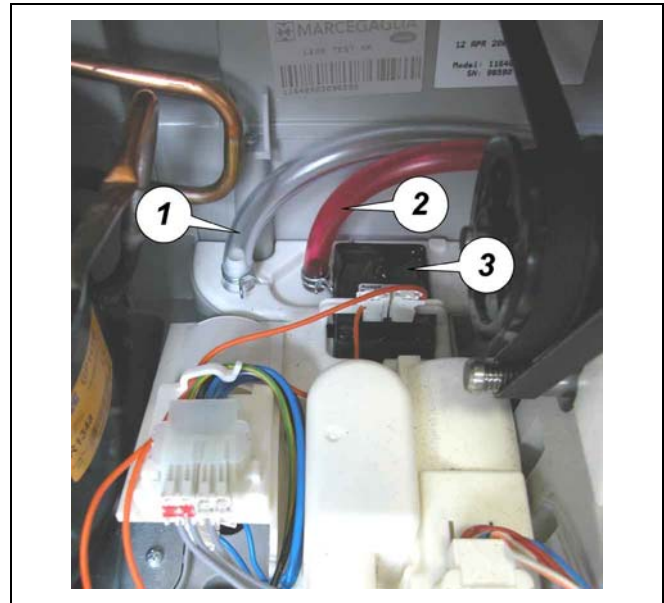

The condensation water from the trap is conveyed to the tank by the pump (3) immersed in the trap through the tube (2).  
When the tank is full, the overflow is collected in the tank and is conveyed back to the trap along the tube (1).

## 5.6 Drum rotation principle

1. Motor
2. Belt tensioner spring
3. Belt tensioner
4. Belt

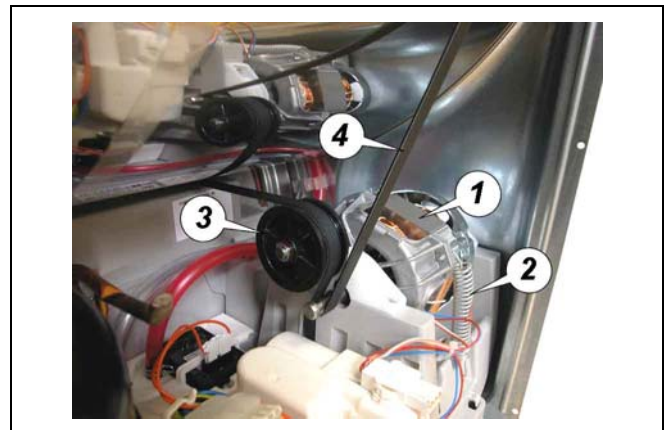

The drum rotation occurs through a belt (4), which is moved by the motor pulley (1) secured to the base. There is a belt tensioner (3) on the motor casing, which increases the angle at which the belt winds onto the drum and works together with the belt tensioner spring (2).

Two-way rotation of the drum is determined by the circuit board, which reverses the direction of power supplied to the motor briefly. The drum rotating in the opposite direction allows the washing to unwind. During these times, the heater unit is cut out.

When the hatch is opened to check the heat exchanger, a micro switch is activated, which cuts off the electricity supply to the tumble dryer.

## 6 Electrical components

### 6.1 Electronic control

The electronic control is made up of a main circuit board in a plastic box, secured behind the control support on which the LCD is positioned, already assembled and tested by the manufacturer.

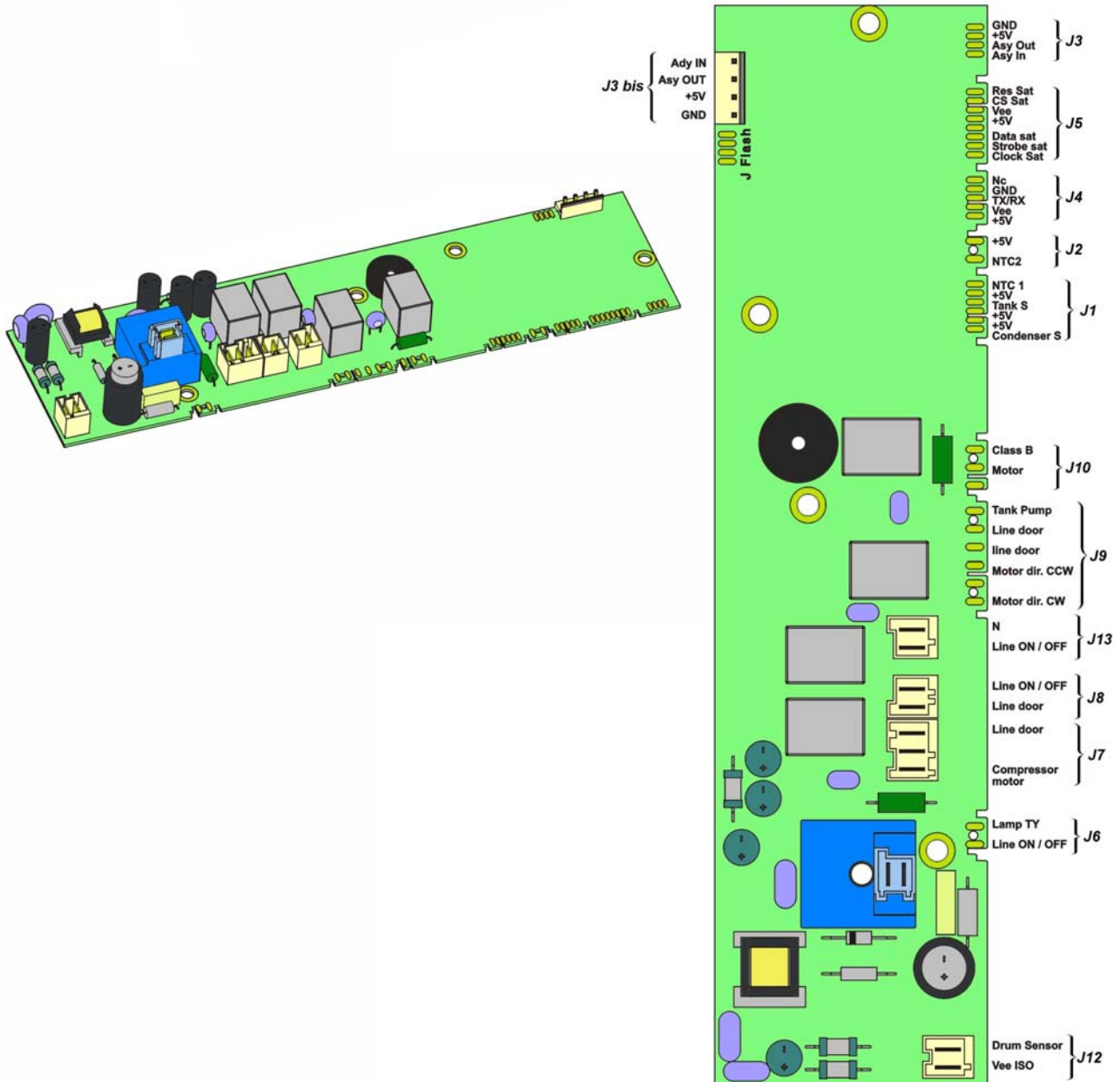

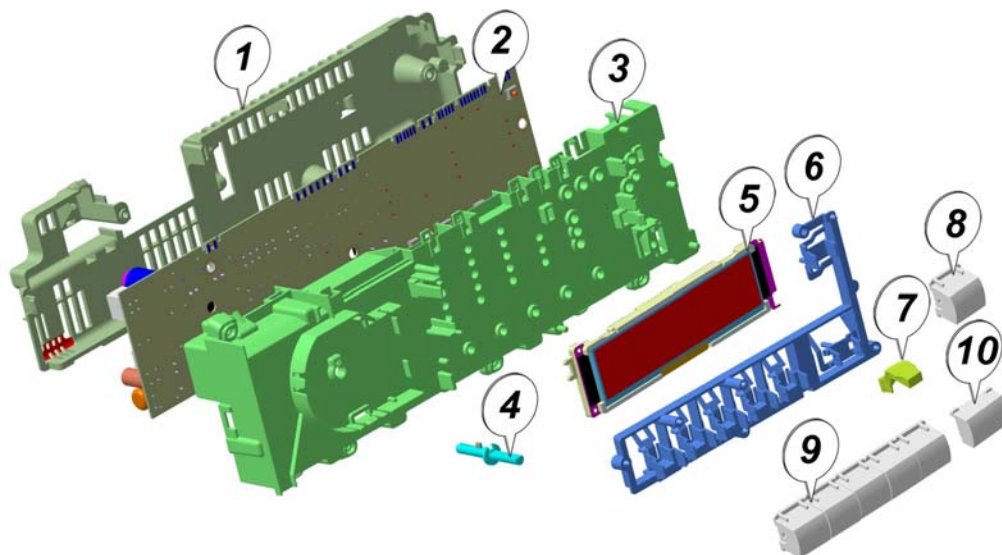

- |                           |                                        |
|---------------------------|----------------------------------------|
| 1. rear board protection  | 6. Buttons spring                      |
| 2. PCB                    | 7. START/PAUSE button LED diffuser.    |
| 3. front board protection | 8. Delay start button.                 |
| 4. selector pin           | 9. Series of programme option buttons. |
| 5. LCD                    | 10. START / PAUSE button               |

## 6.2 Main circuit board functions

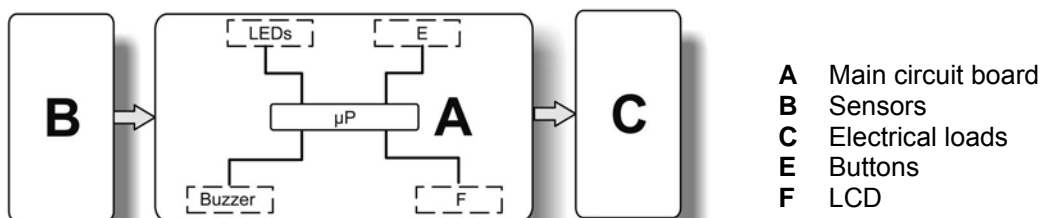

Acquires the commands for the drying cycle set-up through the selector and the various options.

Powers up all the main components: drum rotation motor, condensation water loading pump, heating unit (compressor), compressor cooling fan, main air recirculation fan and door lock.

Controls the status of the door, the air temperature inside the tumble dryer (by means of an NTC probe), the degree of humidity in the washing (by means of the conductivity sensor) and the level of water in the tank through the micro switch plus float situated in the condensation water collection tray in the base.

The buzzer is integrated into the main circuit board.

### 6.3 Electronic control memory: general structure

The main circuit board features an EEPROM memory outside the micro-processor, which allows the recording of the configuration data, the description of the cycle, the status of the appliance in the event of a power failure and the alarms.

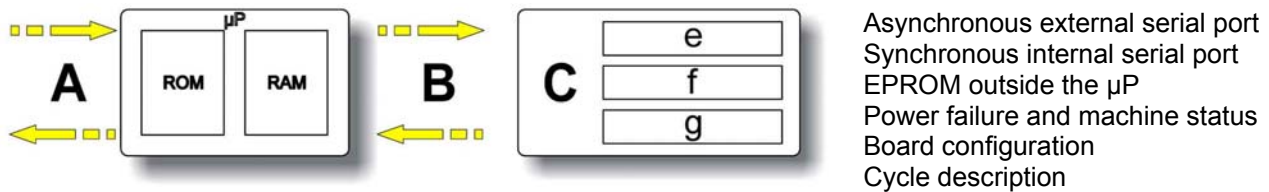

- **ROM**

This area of the memory contains the "firmware" code comprising the appliance functions:  
management of electrical loads (motor, pump, heating unit);  
management of sensors (NTC, conductivity sensor, door switch status);  
management of the user interface;  
management of the serial port;  
management of power failures and alarms;  
execution of the drying programme.

In normal appliances, this area is of the Read Only Memory type, and therefore cannot be modified.

- **RAM**

This memory contains the variables, that is to say all the dynamic information used during running of the programme:

machine status  
cycle selected  
alarms

The memory is deleted every time the power supply stops (in the event of a power failure or when the appliance is turned off).

The contents of the memory can be read using a computer connected via a DAAS interface.

- **EEPROM**

This memory contains various types of data:

Power failure and machine status, that is to say the information required to start the appliance up again in the event of a power failure;

Drying cycle configuration (CCF): this file describes the various steps in the drying cycle for each family of appliances;

Machine configuration: data contained in this section of the memory are those that define the configuration of each individual appliance.

The following are defined in this file:

programmes  
number and functions of buttons  
LED functions  
buzzer operation  
working limits (voltage/frequency)  
machine identification (PNC + ELC + Serial number)  
heating unit power  
preferential direction of rotation of the motor



## 6.4 Conductivity sensor

These electronics use a conductivity sensor, comprising an electronic circuit (located inside the main circuit board) and a part outside the board comprising wiring cables, two brushes, the blades and the drum.

The resistance is measured between the drum (1) and the blades (2).

This value is determined by the quantity, the type of fabric and the humidity level of the washing in the drum.

The brush (3) is in contact with the drum blades via the contacts (5) secured to the contact strip (4) which in turn is insulated from the drum by an insulation strip. The carbon brush (6) in contact with the drum pin is inserted into the drum pin protection (7). The connection between this sensor and the electronic circuit is made through the unit which acts as the earthing system for the appliance's electrical circuit.

When empty, the drum presents infinite resistance between the drum strip and the sensor positioned on the insulated drum blades. The resistance value can be measured again as soon as some damp washing is placed inside it. The value is approximately between  $1M. \div 25M$ . This value is transformed into an oscillation of between approximately  $260Hz \div 0Hz$ , which is read and processed by the electronic circuit (fuzzy logic) and determines the duration and final humidity level of the chosen cycle.

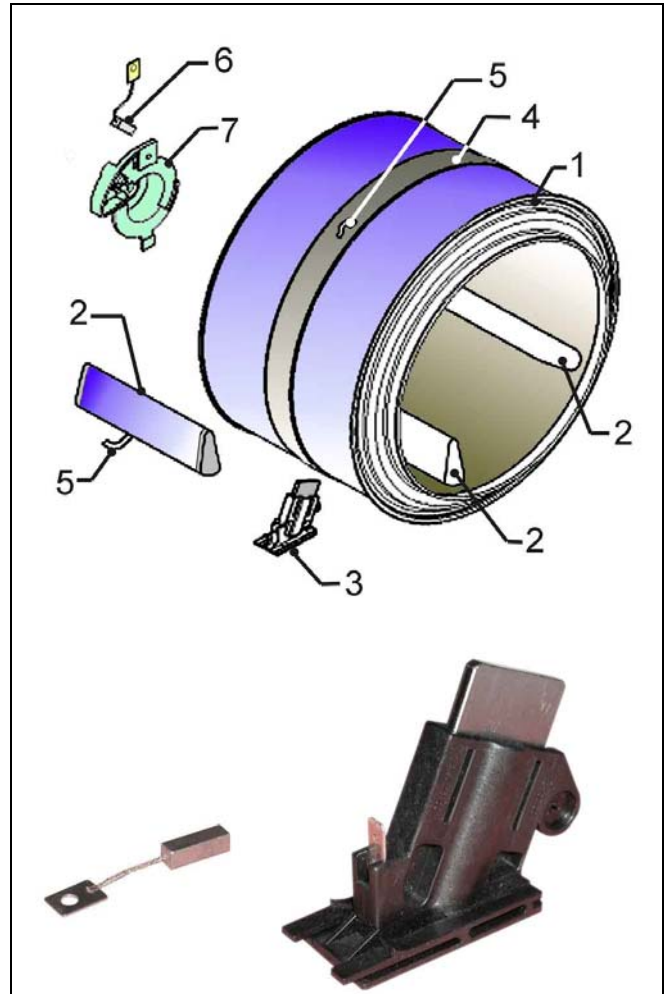

## 6.5 Terminal board with integrated anti-disturbance filter

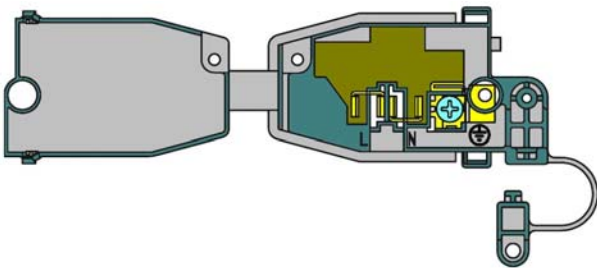

<p>YELLOW label  <math>CX = 0.25 \mu F</math>  <math>CY = 0.27 \mu F</math>  <math>R = 1 M\Omega</math></p>	
<p>FAWN label  <math>C = 0.1 \mu F</math></p>	
<p>CYAN label  <math>CX = 0.25 \mu F</math>  <math>CY = 0.0047 \mu F</math>  <math>R = 1 M\Omega</math></p>	
<p>WHITE label  <math>CX = 0.1 \mu F</math>  <math>CY = 0.0025 \mu F</math>  <math>R = 2.2 M\Omega</math></p>	

The anti-disturbance filter (inserted into the terminal board) is designed to prevent any radio disturbance generated inside the tumble dryer from entering the power supply line.

This device only works correctly if connected to a proper earthing system.

## 6.6 Compressor

The compressor activates the refrigerant fluid circuit (R134a).

Power absorption 670 Watt.  
Main coil resistance  $6.56 \Omega \pm 5\%$   
Auxiliary coil resistance  $5.62 \Omega \pm 5\%$   
Total weight 7.7 kg  
Oil 180 cm<sup>3</sup> NMOC Ze – Gles RB68EP



- A Line.
- B Heat protection.
- C Running capacitor.
- D Auxiliary coil.
- E Primary coil.

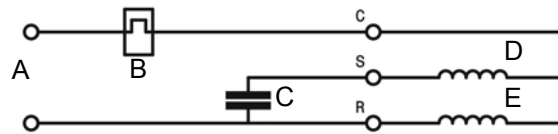

## 6.7 Heat protection

The heat protection is formed by a bimetallic strip which intervenes when the motor - due to excess effort - increases current absorption and consequently rises in temperature.



## 6.8 Compressor motor capacitor

The capacitor enhances the performance of the compressor motor.

18  $\mu$ F 400V



## 6.9 Compressor cooling fan

Axial fan on ball bearings

Power absorption 23 W  
2,600 / 3,000 rpm.



## 6.10 Drum motor

The motor unit is made up of a belt tensioner and the 140W asynchronous, monophasic motor with thermal cut-out.

The motor is powered by the main circuit board through a relay (which determines the rotation direction) and a triac.

It is possible to get an idea of the efficiency of the motor by measuring the resistance of the coils:

Coil A  $28.8 \Omega \pm 7\% \sim$  (contacts 1-3)

Coil B  $28.8 \Omega \pm 7\% \sim$  (contacts 2-3)

- A Connector.
- B Heat protection.
- C Primary coil.
- D Auxiliary coil.
- E Running capacitor.

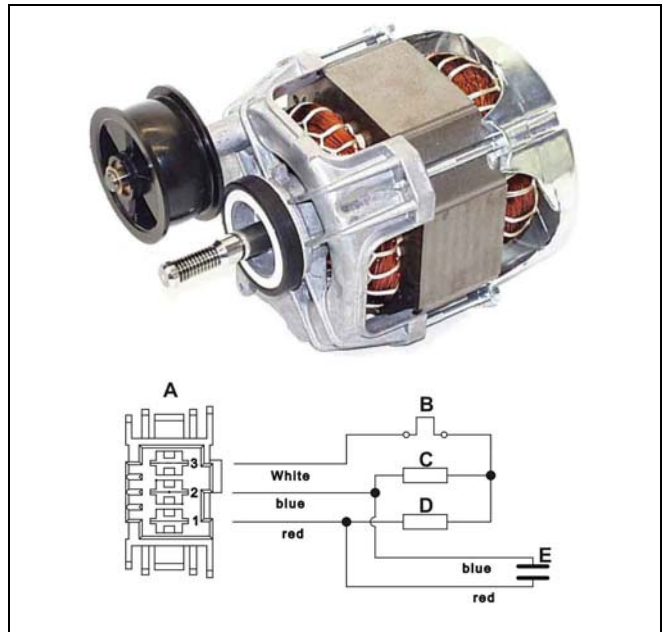

## 6.11 Drum motor capacitor

The drum rotation motor capacitor is connected to points (1) and (2) of the connector and it has a capacity of  $8 \mu\text{F}$ .



### 6.12 Tank loading pump

The pump is activated by a synchronous motor with a power of approximately 17 W. It is used to pump condensation water from the collection tray to the tank. The pump is powered by a triac.

Resistance measured at the tips of the coil ~ 750  $\Omega$



### 6.13 Process power fan

The fan which conveys hot dry air inside the drum is activated by a motor fan secured directly to the inside of the rear air channel.

Power absorption 150 W  
2,450 rpm



### 6.14 Power fan capacitor

The power fan capacitor is connected to points (1) and (2) of the terminal board and it has a capacity of 5  $\mu\text{F}$ .



## 6.15 NTC probe

This probe is secured to the capacitor outlet. It comprises a resistor, inserted in a metal capsule, with a value that decreases as the temperature increases.

The electronic circuit reads the value of the resistor and activates the compressor cooling fan in order to keep the temperature of the refrigerant gas at the capacitor outlet constant.

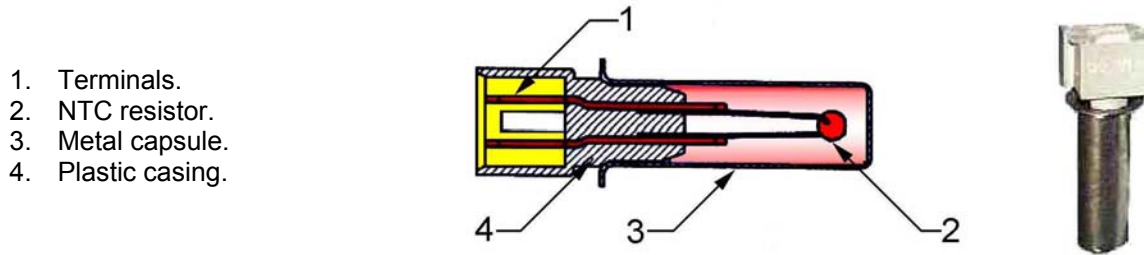

1. Terminals.
2. NTC resistor.
3. Metal capsule.
4. Plastic casing.

TEMPERATURE (°C)	RESISTOR (Ω)		
	Rated value	Maximum value	Minimum value
20	6050	6335	5765
60	1250	1278	1222
80	640	620	660

## 6.16 Door switch

The door switch powers the electrical components after the door has been closed and after the selector has been turned (ON/OFF closed). The switch is located above the door opening and it is closed, when the door itself is closed, by means of a pin located on the door itself.

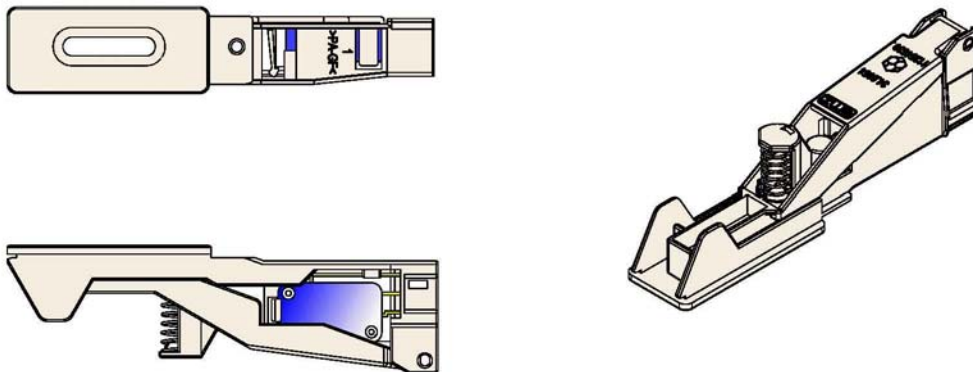

## 6.17 Door lock

Depending on the version, the door lock may be mechanical with manual door opening or electronic with the door opening when a button is pressed. In the second case the door is opened by an electromagnetic coil which releases the fastening latch by means of a lever.

The door lock is fitted with a child safety device which, in case of need, allows the door to be opened by pushing from the inside.

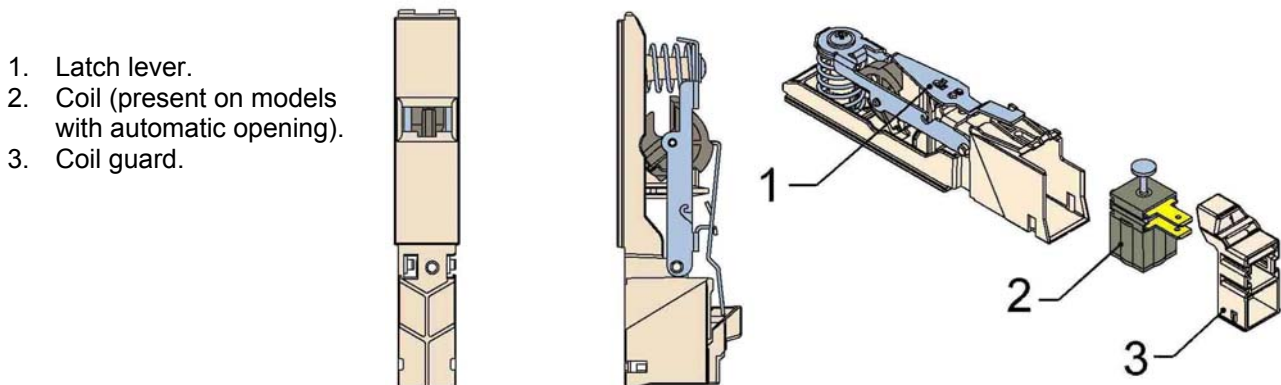

1. Latch lever.
2. Coil (present on models with automatic opening).
3. Coil guard.

# 7 Wiring diagram

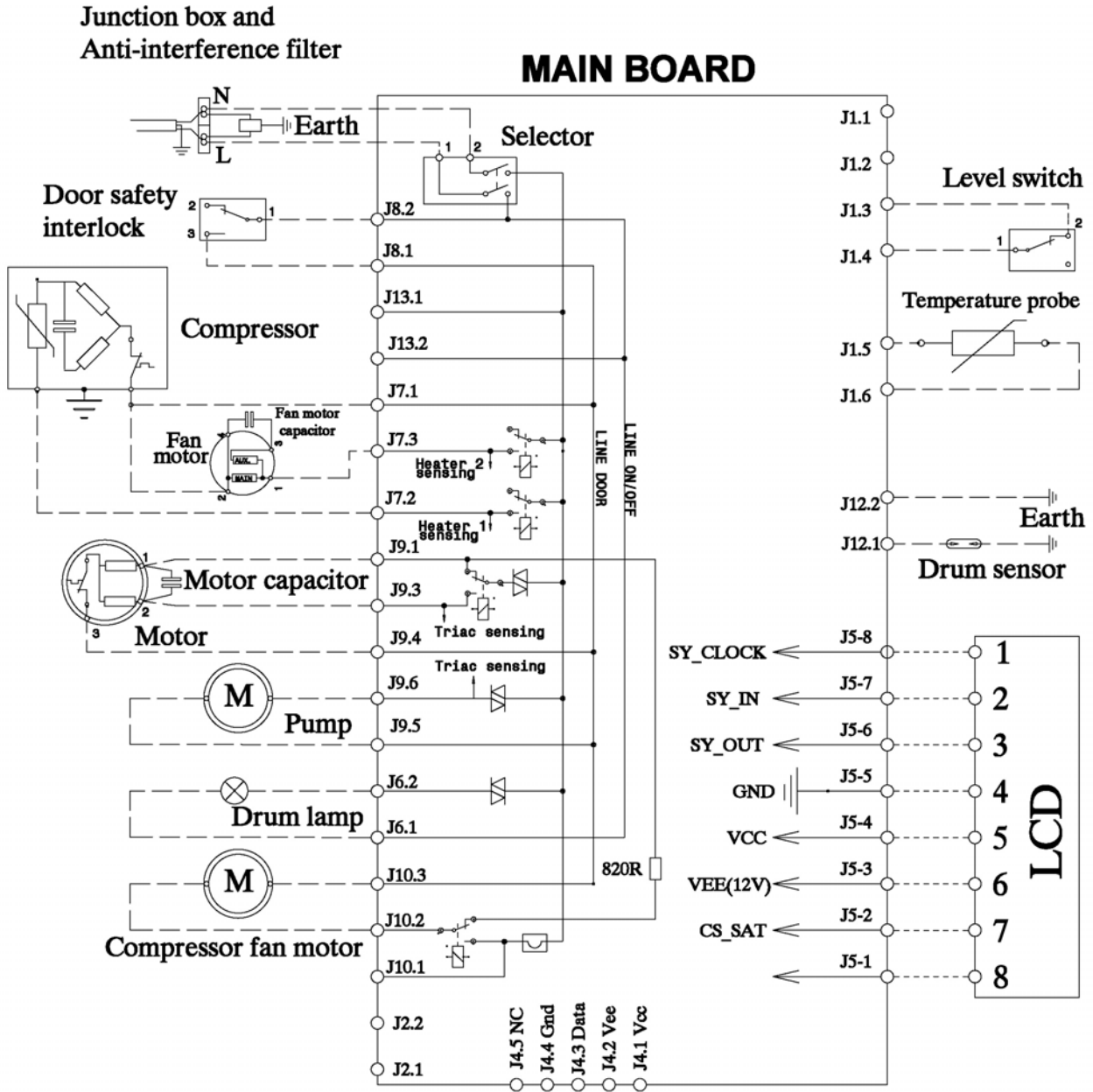

## 8 Diagnostics system

This mode allows to check appliance operations and to read alarms.

### 8.1 Accessing diagnostics

- The appliance must be turned off.
- Turn the appliance on, turning the programme selector by one position in a clockwise direction.
- Wait until the LEDs light up and the buzzer sounds, then press the START/PAUSE button and the first button to the left of it simultaneously.
- Keep pressing the buttons until the LEDs start to flash and the buzzer sounds.

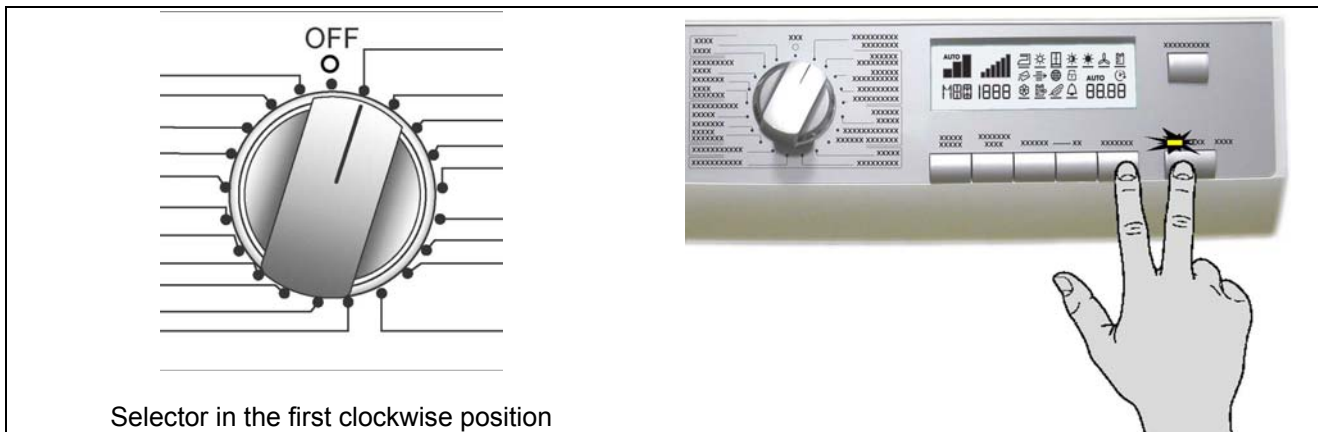

Warning: this operation must be carried out within 5 seconds!

### 8.2 Quitting the diagnostics system

To quit the diagnostics system, turn the programme selector to position zero, turn the appliance on so as to reset all the functions, then turn the appliance off again.



- The alarms are active during diagnostic testing of components.  
If an alarm appears, move the selector to the first position to exit the alarm status and, if necessary, continue the test (if the alarm is not triggered again).
- To check the correct functioning of the float switch and pump, the trap should be filled with approximately 0.7 litres of water.
- In order to test the conductivity sensor properly in case of a short-circuit, create a short-circuit between the blade and the drum.  
The time available to create the short-circuit, when in this phase, is just one second; consequently, arrange the short-circuit before moving the selector.  
If the short-circuit is not created properly, the circuit board will display alarm E32 (sensor frequency too low). To exit this alarm, move the selector to the first position.

Selector positions for diagnostics on appliances with conductivity sensor



When entering the various functions in diagnostics mode, in those models featuring an LCD, wording is displayed at the bottom right of the screen (such as C7 – C5 etc.). These are merely the coding of the selector and have no relevance to the test in progress.

**Position 1**

User interface test	Purpose of the test:	to test the correct functioning of all the LEDs and switches.
	Components activated:	all the LEDs and the LCD display.
	Behaviour	<p>All the LEDs light up in sequence.</p> <p>When any button is pressed the corresponding icon lights up.</p> <p>The code is shown on the LCD display and a buzzer sounds.</p> <p>All the icons in the LCD display flash.</p>
	Operating conditions:	there is a control for the test performance (always active).

**Position 2**

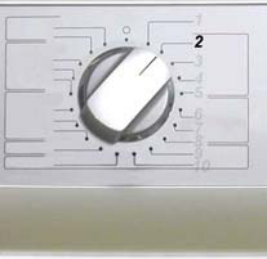
Float micro-switch. Condensation collection tray pump.	Purpose of the test:	to test the pump that conveys condensation water to the tank and the micro-switch of the condensation water collection tray.
	Components activated:	if the condensation water collection tray is full, the float micro-switch recognises this condition and activates the loading pump.
	Behaviour:	<p>000 flashes on the LCD until the condensation water collection tray micro-switch trips to the "tray full" position.</p> <p>When the micro-switch trips to the "tray full" position, the LCD displays III.</p>
	Operating conditions:	door closed (timeout 10 secs.)

**Position 3**

Anti-clockwise drum rotation.	Purpose of the test:	to test the drum rotation motor in an anti-clockwise direction.
	Components activated:	<p>motor TRIAC and direction relay.</p> <p>In this position, the pump which conveys condensation water to the tank is also activated (request made by the assembly line).</p>
	Behaviour:	the LEDs are on and the drum rotates in an anti-clockwise direction.
	Operating conditions:	door closed (timeout 10 mins.)



#### Position 4

Reduced clockwise drum rotation.



Purpose of the test:	to test the drum motor in a clockwise direction.
Components activated:	drum rotation motor TRIAC. The motor runs at low speed.
Behaviour:	the phase LEDs are on, the drum rotates in steps clockwise.
Operating conditions:	door closed (timeout 10 mins.)

#### Position 5

Clockwise drum rotation.  
Power fan

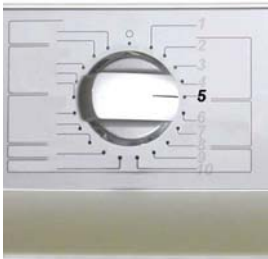

Purpose of the test:	to test the motor in a clockwise direction. The power fan TRIAC. The power fan operation.
Components activated:	clockwise drum rotation motor. Power fan.
Behaviour:	The drying temperature NTC1 is displayed on the LCD.
Operating conditions:	door closed (timeout 10 secs.)



#### Position 6

Clockwise drum rotation.  
Power fan.  
Compressor.

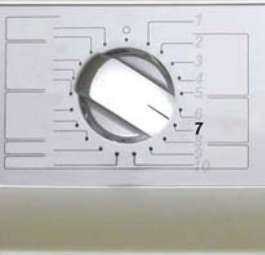

Purpose of the test:	to test the motor in a clockwise direction. The power fan TRIAC. The power fan operation. The compressor operation. Compressor cooling fan.
Components activated:	clockwise drum rotation motor. Power fan. Compressor motor. Compressor cooling fan.
Behaviour:	the drying temperature NTC1 is displayed on the LCD.
Operating conditions:	door closed (timeout 10 secs.)
	 <p>On completion of the test, the compressor will only start up again after a 5-minute pause.</p>

### Position 7

Conductivity sensor, short-circuited drum.	Purpose of the test:	to check the conductivity sensor in short-circuit conditions.
	Components activated:	conductivity sensor unit (brushes - wiring - board).
	Behaviour:	<p>the test lasts 4 seconds, during which 000 flashes on the LCD.</p> <p>If the result is correct at the end, III flashes on the LCD.</p> <p>if it is not correct, 000 continues to flash on the LCD and the alarm E32 is shown.</p>
	Operating conditions:	door closed.
		Prepare the short-circuit before performing the test.

### Position 8

Conductivity sensor, open-circuited drum.	Purpose of the test:	to check the conductivity sensor in open-circuit conditions.
	Components activated:	conductivity sensor unit (brushes - wiring - board).
	Behaviour:	<p>the test lasts 4 seconds, during which 000 flashes on the LCD.</p> <p>If the result is correct at the end, III flashes on the LCD.</p> <p>If it is not correct, 000 continues to flash on the LCD.</p>
	Operating conditions:	door closed.

### Position 9

Condensation collection tray float micro-switch.	Purpose of the test:	to test the operation of the micro-switch situated above the condensation water collection tray.
	Components activated:	<p>float micro-switch.</p> <p>Water loading pump.</p>
	Behaviour:	<p>if the water collection tray is full of water, the tank switch recognises this condition and the pump starts up, the phase LEDs flash until the condensation tank switch trips to the "full" position.</p> <p>When the switch trips to the "empty" position, the LEDs and the pump are turned off.</p>
	Operating conditions:	door closed.

### Position 10

Display last alarm and reset, if necessary.

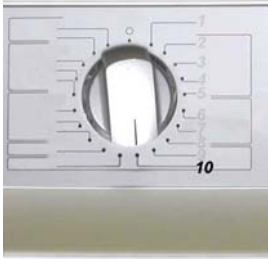

Purpose of the test:

to display any alarms and delete them.

Behaviour:

the LCD displays the alarm while the LED corresponding to the alarm flashes.

Operating conditions:

press the START/PAUSE button to check for any other alarms.

Press the START/PAUSE buttons and the first button to its left simultaneously until the display shows E00.

## 9 Alarms

### 9.1 Displaying the alarms to the user

Alarm management can be configured so that they can be partially or totally visible to the user, depending on the model.

Normally, all alarms except E61, E97 and EB2 are visible to users.

When an alarm occurs, the drying cycle may be stopped or paused; in certain cases a forced cooling cycle is started, for safety, and the drum cooling fan motor is powered. The cycle remains in operation until the user turns the appliance off.

### 9.2 Viewing alarms during normal operation

The family of the current alarm is displayed for the user.

Let us take alarm E53 (problem with the motor TRIAC) as an example; the following will be displayed:

- first digit: letter “**E**” (error);
- second and third digit: the number “**5 0**”, i.e. the family of the alarm E53.



The same number is displayed by a repeated sequence of flashes of the START LED with a cycle (0.4 seconds on, 0.4 seconds off with a 2.5 second pause in between sequences); in the case of E53, the series of five flashes indicates the first of the two digits of the alarm **E53** (alarms related to the same function are grouped into families).

### 9.3 Reading the alarms

To read the last alarm stored in the circuit board EEPROM:

- start diagnosis mode (see paragraph);
- turn the programme selector in a clockwise direction to position ten , taking care not to stop at the other positions, as this might trigger error 32.
- First digit: letter “**E**”
- Second digit: the family of the alarm
- Third digit: the number of the alarm

### 9.3.1 Viewing any other alarms

Press the START button to view all alarms present in the machine in succession.

### 9.3.2 Deleting the last alarm

It is good practice to delete all the alarms stored:

- after you have read them, to check whether or not they occur again during diagnostic tests;
- after repairing the appliance, to check whether they re-occur during testing.

1. Start diagnosis mode (see paragraph).
2. Turn the programme selector in a clockwise direction to position ten.
3. Press the (start/pause) button and the first button to its left simultaneously.
4. Keep them pressed for approximately 5 seconds.
5. After deleting, **E00** will be displayed.

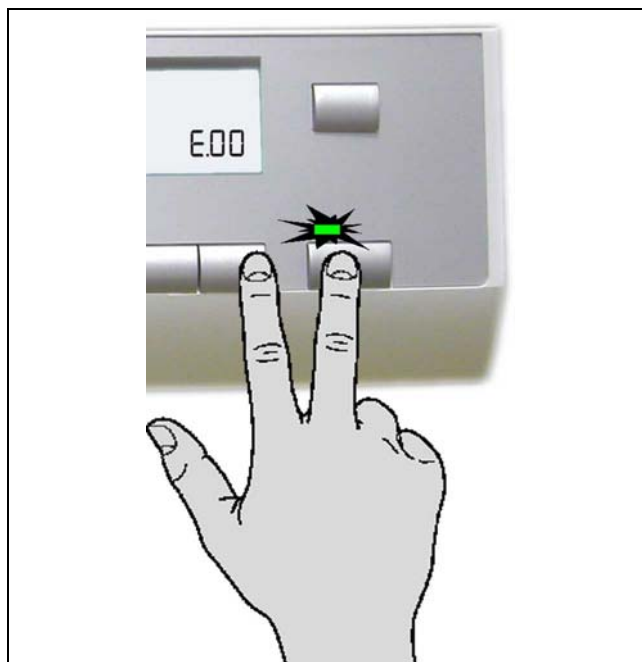

### 9.3.3 Notes on the behaviour of certain alarms

- **Configuration alarm E93:** when these alarms are detected (on start-up) the machine will stop and all the LEDs will light up: it will not be possible to access diagnostics mode and the only available option is to turn the appliance off (selector set to position "0").
- **Alarms EH1-EH2-EH3:** in the event of problems with the supply voltage, the machine will remain in a state of alarm until the mains frequency or voltage returns to normal values or until the appliance is turned off (programme selector set to "0"). The alarm family "**H**" is displayed and the diagnostics mode cannot be accessed and the "quick alarm viewing" mode cannot be used: the alarm can only be read in full when the situation has normalised.

## 9.4 Alarm Summary Table

FAMILY	ALARM CODE	Short name	Full name	Action	Notes and possible causes	
Ex20	CONDENSATION WATER LOADING PUMP	Ex21	PUMP_TRIAC_AL	Condensation water loading pump alarm.	<ul style="list-style-type: none"> <li>The cycle is suspended.</li> <li>If it is detected before the cycle starts, the cycle start will not be permitted.</li> </ul>	<ul style="list-style-type: none"> <li>Water loading pump disconnected (wiring or connector error).</li> <li>Loading pump faulty.</li> <li>Water loading pump control TRIAC error (short-circuit, diode mode, open circuit) (power board error).</li> </ul>
		Ex22	PUMP_TRIAC_S_AL	Condensation water loading pump detection alarm.	<ul style="list-style-type: none"> <li>The cycle is suspended.</li> <li>If it is detected before the cycle starts, the cycle start will not be permitted.</li> </ul>	<ul style="list-style-type: none"> <li>Pump TRIAC detection circuit error (main board error).</li> </ul>
Ex30	CONDUCTIVITY SENSOR	Ex31	SENS_F_TOO_HIGH_AL	Frequency of the conductivity sensor too HIGH.	No action.	<p>Only active during diagnostics of the HUMIDITY SENSOR SHORT-CIRCUIT.</p> <ul style="list-style-type: none"> <li>The oscillation frequency is out of range (main board error).</li> </ul>
		Ex32	SENS_F_TOO_LOW_AL	Frequency of the conductivity sensor too LOW.	No action.	<p>Only active during diagnostics of the HUMIDITY SENSOR SHORT-CIRCUIT.</p> <ul style="list-style-type: none"> <li>The drum is not short-circuited.</li> <li>Wiring error.</li> <li>The oscillation frequency is out of range (main board error).</li> </ul>
Ex40	DOOR	Ex45	DOOR_CLOSED_S_AL	Door closed detection alarm.	<ul style="list-style-type: none"> <li>The cycle is suspended.</li> <li>If it is detected before the cycle starts, the cycle start will not be permitted.</li> </ul>	<ul style="list-style-type: none"> <li>Error in the door closed detection circuit.</li> <li>Door micro-switch faulty or disconnected.</li> <li>Main board error.</li> </ul>

FAMILY		ALARM CODE	Short name	Full name	Action	Notes and possible causes
E0x50	DRUM ROTATION MOTOR	Ex51	MOTOR_TRIAC_AL	Drum rotation motor alarm	<ul style="list-style-type: none"> <li>▪ The cycle is suspended.</li> <li>▪ If it is detected before the cycle starts, the cycle start will not be permitted.</li> </ul>	<ul style="list-style-type: none"> <li>▪ Drum motor disconnected (wiring or connector faulty).</li> <li>▪ Drum motor capacitor (disconnected or faulty).</li> <li>▪ Drum rotation motor faulty.</li> <li>▪ Drum rotation motor TRIAC error (short-circuit, diode mode, open circuit) (main board error).</li> </ul>
		Ex52	MOTOR_TERM_AL	Drum motor heat protection cut-off alarm.	<ul style="list-style-type: none"> <li>▪ It deactivates the motor for a given period of time, while waiting for the temperature to stabilise, if necessary.</li> <li>▪ If normal operating conditions are not restored within approximately 30 minutes, alarm 0x51 is triggered.</li> </ul>	
		Ex53	MOTOR_TRIAC_S_AL	Drum rotation motor detection alarm	<ul style="list-style-type: none"> <li>▪ The cycle is suspended.</li> <li>▪ If it is detected before the cycle starts, the cycle start will not be permitted.</li> </ul>	<ul style="list-style-type: none"> <li>▪ Drum rotation motor TRIAC detection circuit error (main board error).</li> </ul>
		Ex54	MOTOR_JAMMED	Alarm signalling the motor has jammed.	<ul style="list-style-type: none"> <li>▪ When the motor is unable to start the rotation within 5 seconds of the activation command, a procedure is triggered to repeat this attempt. The motor is suspended for 10 seconds, and then it is activated again. If rotation still does not start, the procedure continues (180 times), then an alarm is displayed and the cycle is paused.</li> <li>▪ To delete the alarm and the cycle, simply press START.</li> </ul>	<ul style="list-style-type: none"> <li>▪ Drum load too much.</li> <li>▪ Power supply voltage too low.</li> <li>▪ Mechanical failures.</li> <li>▪ Drum rotation motor capacitor (disconnected or faulty).</li> <li>▪ Drum rotation motor faulty.</li> </ul>

FAMILY		ALARM CODE	Short name	Full name	Action	Notes and possible causes
Ex60	COMPRESSOR	Ex62	COMP_RELAY_FAIL	Heat pump compressor alarm.	<ul style="list-style-type: none"> <li>The cycle is suspended.</li> <li>If it is detected before the cycle starts, the cycle start will not be permitted.</li> </ul>	<ul style="list-style-type: none"> <li>Compressor disconnected (wiring or connector faulty).</li> <li>Compressor faulty.</li> <li>Motor protector faulty or tripped.</li> <li>Piloting relay error (mother board error).</li> </ul>
		Ex63	COMP_AUT_THERM,	Compressor thermal alarm	<ul style="list-style-type: none"> <li>It deactivates the compressor for a given period of time, while waiting for the temperature to stabilise, if necessary.</li> <li>If normal operating conditions are not restored within approximately 30 minutes, alarm 0x62 is triggered.</li> </ul>	
		Ex64	COMPRESSOR_S_AL	Compressor detection alarm.	<ul style="list-style-type: none"> <li>The cycle is suspended.</li> <li>If it is detected before the cycle starts, the cycle start will not be permitted.</li> </ul>	<ul style="list-style-type: none"> <li>Compressor detection circuit error (mother board error).</li> </ul>
		Ex65	MAIN_FAN_TRIAC_AL	Main fan alarm	<ul style="list-style-type: none"> <li>The cycle is suspended.</li> <li>If it is detected before the cycle starts, the cycle start will not be permitted.</li> </ul>	<ul style="list-style-type: none"> <li>Main fan motor disconnected (wiring or connector error).</li> <li>Main fan motor error.</li> <li>Main fan motor TRIAC error (short-circuit, diode mode, open circuit) (satellite board error).</li> </ul>
		Ex66	MAIN_FAN_AUT_THERM	Main fan thermal cut-off alarm	<ul style="list-style-type: none"> <li>It deactivates the main fan and the compressor for a given period of time, while waiting for the temperature to stabilise, if necessary.</li> <li>If normal operating conditions are not restored within approximately 30 minutes, alarm 0x66 is triggered.</li> </ul>	
		Ex67	MAIN_FAN_TRIAC_S_AL	Main fan detection alarm	<ul style="list-style-type: none"> <li>The cycle is suspended.</li> <li>If it is detected before the cycle starts, the cycle start will not be permitted.</li> </ul>	<ul style="list-style-type: none"> <li>Main fan TRIAC detection circuit error (mother board error).</li> </ul>



FAMILY		ALARM CODE	Short name	Full name	Action	Notes and possible causes
0x70	NTC	Ex71	DRYING_NTC1_AL	Drying NTC alarm	<ul style="list-style-type: none"> <li>The cycle is suspended.</li> <li>If it is detected before the cycle starts, the cycle start will not be permitted.</li> </ul>	NTC1 reading out of range. <ul style="list-style-type: none"> <li>Wiring faulty.</li> <li>NTC faulty.</li> <li>NTC reading circuit error (main board error).</li> </ul>
0x80	IU	Ex82	WRONG_RESET_POSITION_AL	Wrong reset position on selector	<ul style="list-style-type: none"> <li>The cycle is suspended.</li> <li>If it is detected before the cycle starts, the cycle start will not be permitted.</li> </ul>	The mother board is also powered in the RESET position (OFF position). <ul style="list-style-type: none"> <li>Selector pin not in seat or broken.</li> <li>Faulty wiring.</li> <li>Selector faulty (mother board error).</li> </ul>
		Ex83	WRONG_SELECTOR_READ_AL	Wrong selector code	No action.	The code for the selector position is not recognised. <ul style="list-style-type: none"> <li>Wrong selector configuration.</li> <li>Selector error (mother board error).</li> </ul>
Ex90	CFG	Ex93	CFG_AL	MCF checksum alarm	<ul style="list-style-type: none"> <li>The appliance does not function correctly unless it is programmed appropriately.</li> </ul>	<ul style="list-style-type: none"> <li>Incorrect appliance configuration file.</li> </ul>
		Ex94	CFG_CYC_AL	CCF checksum alarm	<ul style="list-style-type: none"> <li>The appliance does not function correctly unless it is programmed appropriately.</li> </ul>	
		Ex97	SCFCTF_MISMATCH_AL	Missing programme on CTF alarm	<ul style="list-style-type: none"> <li>Only detected when configuration is performed.</li> <li>Does not allow the cycle to start.</li> </ul>	<ul style="list-style-type: none"> <li>Wrong selector configuration (MCF).</li> <li>Cycle missing from the cycle table (CCF).</li> </ul>

FAMILY		ALARM CODE	Short name	Full name	Action	Notes and possible causes
ExB0 (ExH0)	POWER SUPPLY	ExB1 Exh1	BAD_FREQ_AL	Power supply frequency out of range	<ul style="list-style-type: none"> <li>▪ If detected during configuration, the cycle start will not be permitted.</li> <li>▪ If it occurs while the cycle is running, operation is suspended.</li> <li>▪ It is automatically deleted when the normal power supply limits are restored, thus allowing the automatic start-up of the cycle which had been temporarily suspended because of this error.</li> </ul>	<ul style="list-style-type: none"> <li>▪ Power supply problems.</li> <li>▪ Incorrect MCF.</li> <li>▪ Main board error.</li> </ul>
		ExB2 Exh2	VOLT_TOO_HIGH_AL	Power supply voltage out of range (too HIGH)		<ul style="list-style-type: none"> <li>▪ Power supply problems - VOLTAGE TOO HIGH.</li> <li>▪ Incorrect MCF.</li> <li>▪ Main board error.</li> </ul>
		ExB3 Exh3	VOLT_TOO_LOW_AL	Power supply voltage out of range (too LOW)		<ul style="list-style-type: none"> <li>▪ Power supply problems - VOLTAGE TOO LOW.</li> <li>▪ Incorrect MCF.</li> <li>▪ Main board error.</li> </ul>

# 10 Troubleshooting

## 10.1 The diagnostics programme cannot be accessed

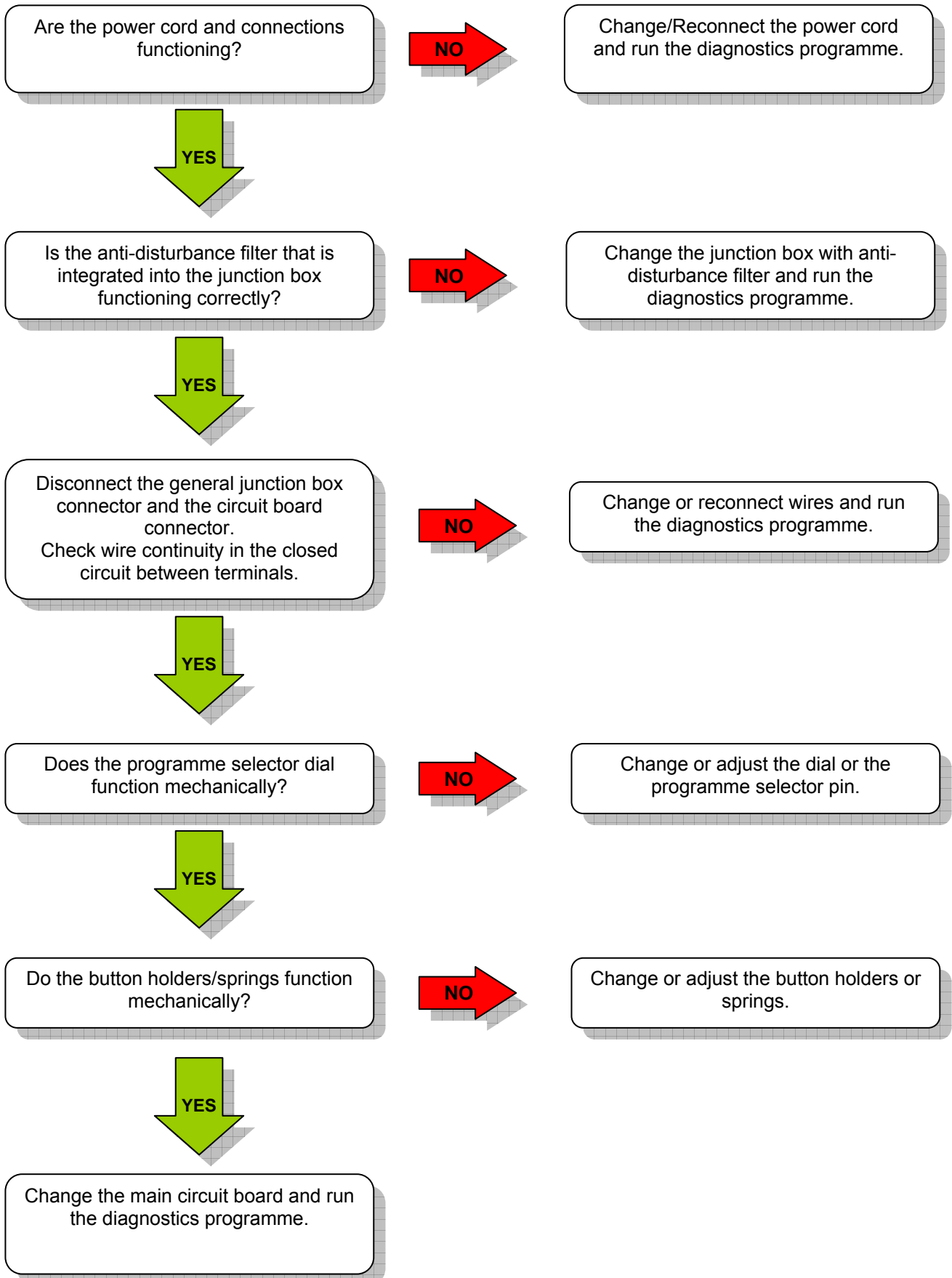

## 10.2 The LEDs do not light up after the buttons are pressed

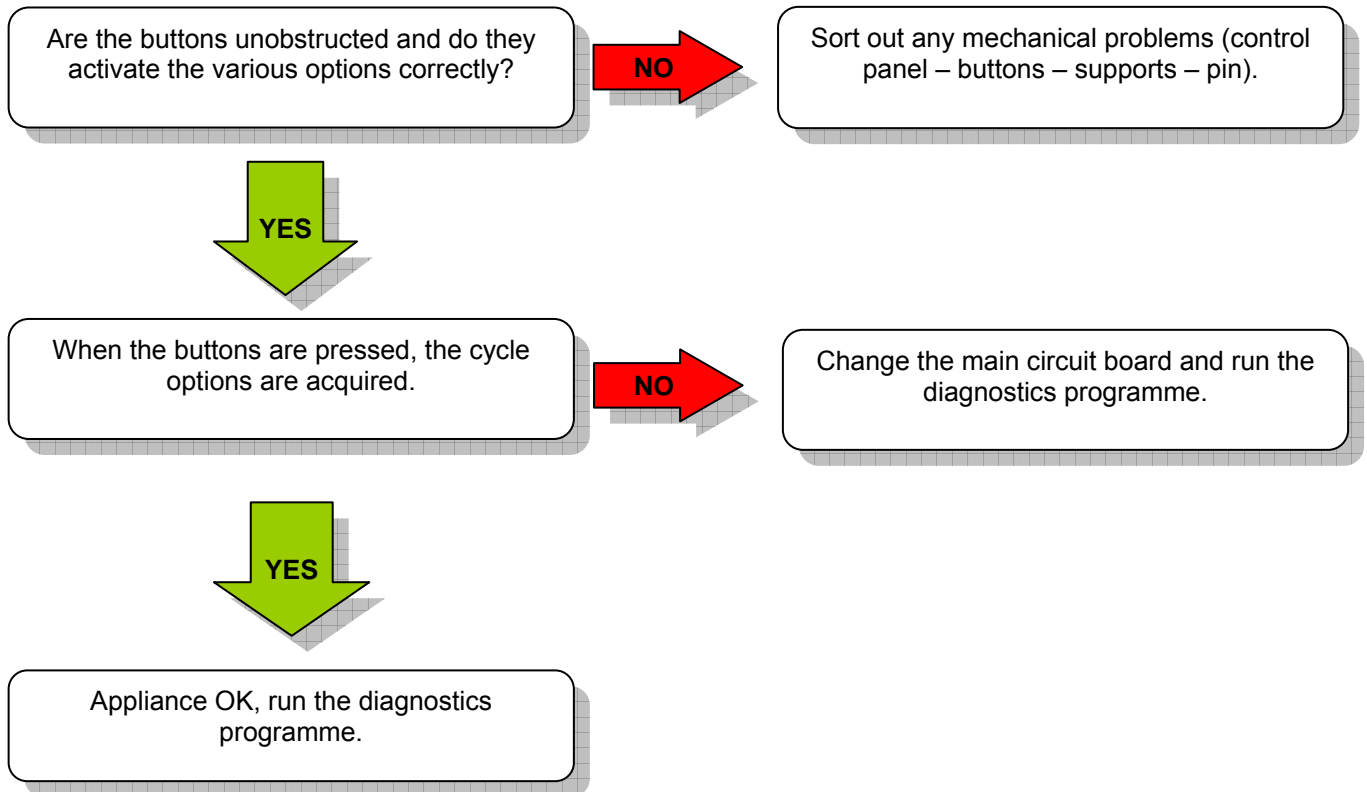

### **Important!**

*You cannot access the diagnostics system if the main circuit board has not been configured correctly: configuration errors E93 E94 are displayed by the flashing of all LEDs.*

### 10.3 The drying cycle is long and the washing is still damp.

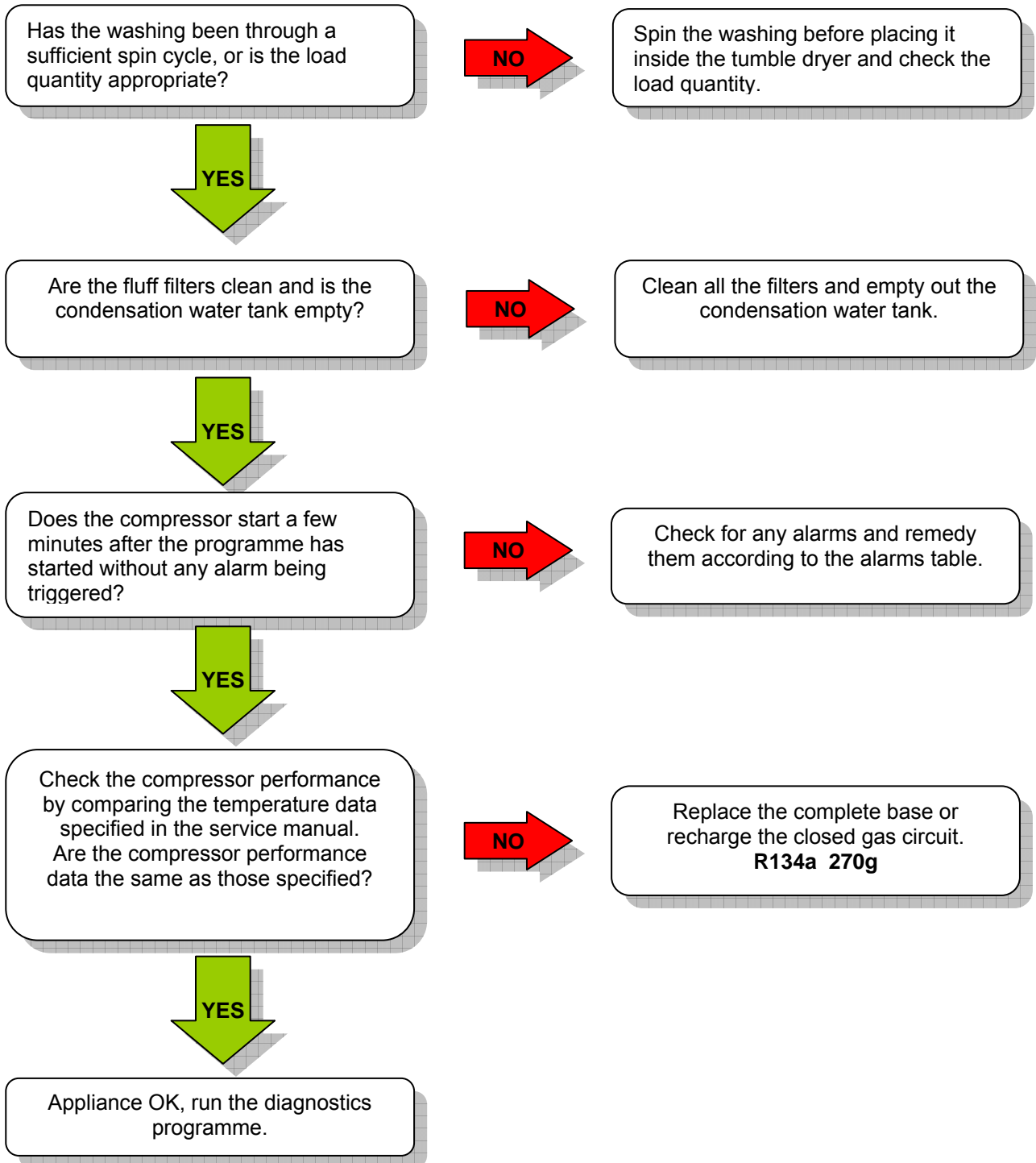

## 11 Accessing components

### 11.1 door

- To remove the door, loosen the screws securing it to the appliance front.



### 11.2 Fluff filters

#### 11.2.1 Door fluff filter

- Open the filter support by pressing the purpose-provided button.
- Remove the filter upwards and clean it at the end of every cycle.

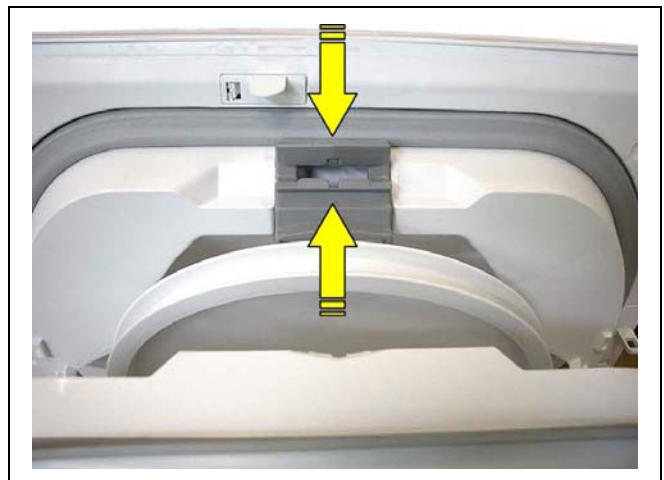

#### 11.2.2 Lower fluff filter

- Remove the filter from its seat upwards and clean it at the end of every cycle.



### 11.2.3 Evaporator fluff filters

- Open the door by pressing the purpose-provided button.
- Pull out the evaporator fluff filter support.
- Press on the two locking clips on either side of the filter support and remove it by pulling it upwards.

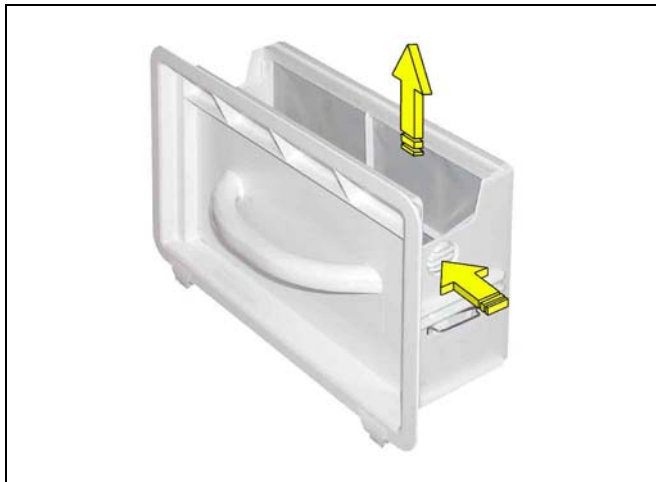

### 11.2.4 Evaporator water fluff filter

Another filter situated beneath the fluff filter support is used to prevent condensation water soiled with micro fluff from reaching the pump and clogging it.

- To remove it, simply lift it and extract it.

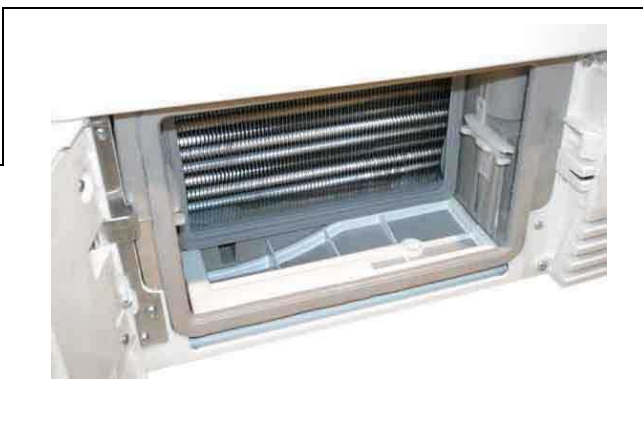
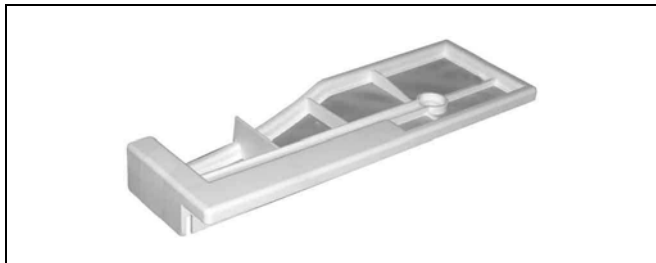

### 11.3 Compressor fan motor

The compressor cooling fan is situated at the front beneath the right side of the kick plate.

- Loosen the two fixing screws, move the cover slightly towards the left and remove the kick plate.
- Move the two clips securing the motor in place upwards, turn the motor slightly forward, then remove it.

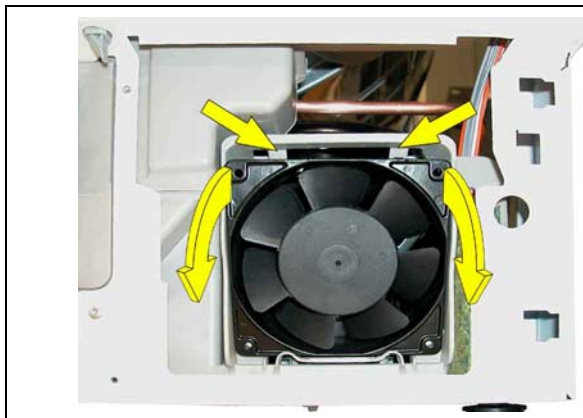

### 11.4 Door lock

- Unfasten the screw that secures it in place.
- Lower it slightly and pull it out, turning it forwards.

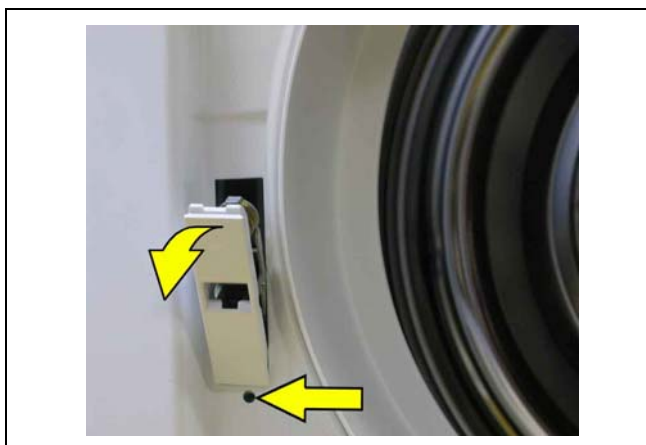

### 11.5 Door micro-switch

- Loosen the fixing screw, pull it out slightly and move it towards the left to get to the connector.
- Disconnect the connector and fasten it to the front with a piece of cello tape to prevent it from going back into the machine.

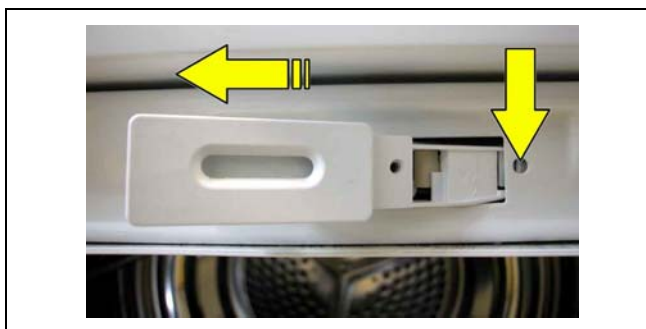



## 11.6 Door fastening latch and door micro-switch latch

For the door fastening latch:

- unfasten the screw that secures it in place;
- with a screwdriver, press on the retainer hook and turn it in the direction indicated by the arrow

for the door micro-switch latch:

- with a screwdriver, press on the retainer hook and turn it in the direction indicated by the arrow.

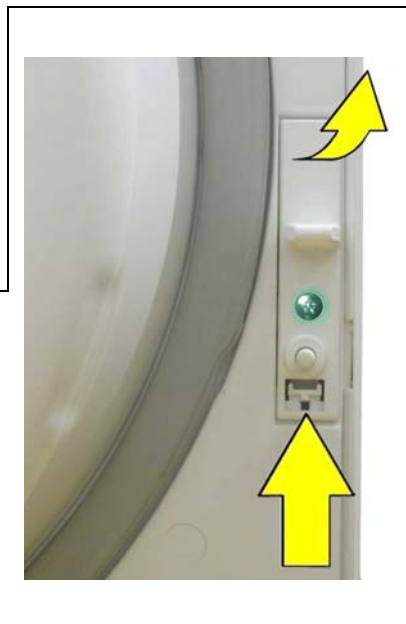

## 11.7 Drum lamp

The drum lamp can be replaced from inside the drum.

- Unscrew the lamp cover and replace the lamp with one of the same wattage.



When replacing the lamp cover, make sure that the gasket is properly positioned in the housing.



## 11.8 Tank

- Pull the tank out completely, taking care not to spill any water inside it onto electrical parts.

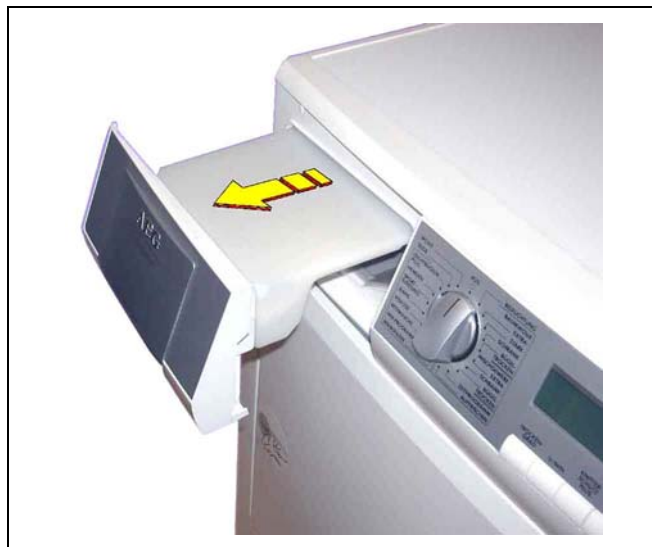

## 11.9 Worktop

- Loosen the two screws that secure it to the rear of the tumble dryer and pull it out by pushing it towards the back.

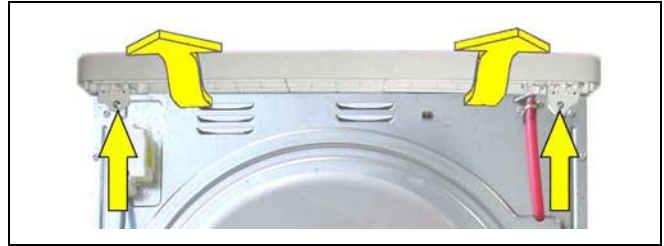

## 11.10 Control support and control panel assembly

- Remove the tank and loosen the screws that secure the control panel to the tank.
- Loosen the screws that secure the controls crossbar and turn the entire crossbar forwards together with the control panel.

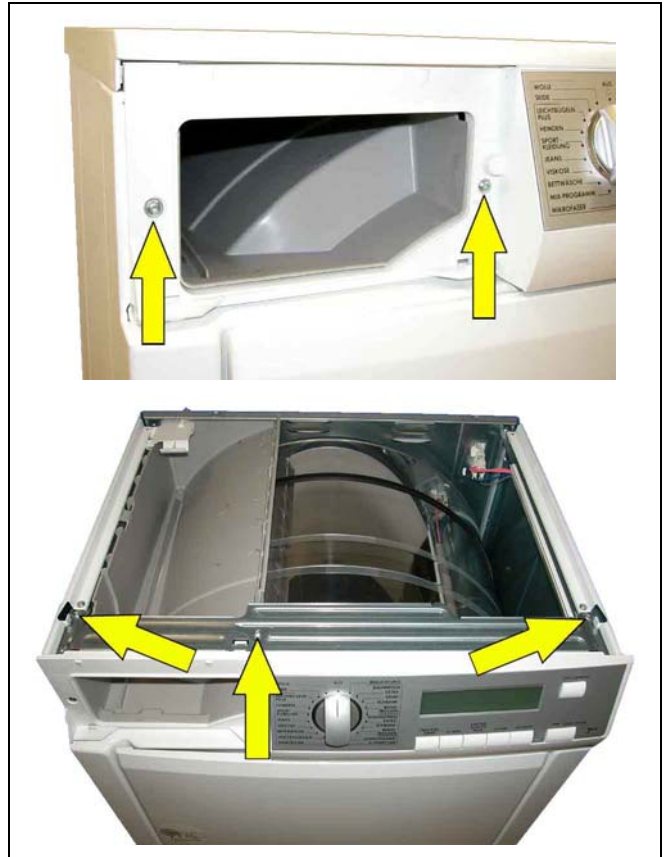

## 11.11 Main circuit board

### 11.11.1 Removing the board

- Once you have removed the entire control panel, disconnect all the wiring, taking care to make a note of their position for subsequent reassembly.
- Remove the main circuit board by loosening the 8 screws securing it to the control panel.
- Use a screwdriver to lever off the fixing clips without straining them too much, and remove the board.

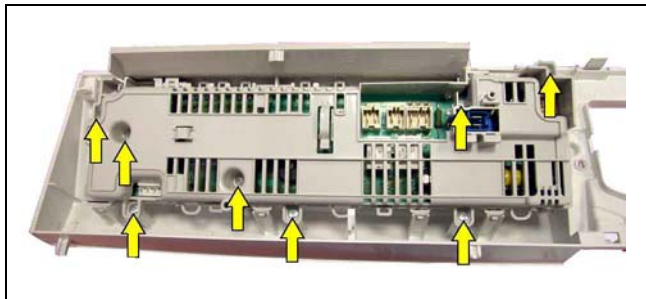

### 11.11.2 Removing the selector pin

- The selector pin can be removed after removing the main circuit board.
- Set the selector pin to position **OFF** and pull it out.



#### WARNING

If the pin does not come out, check carefully to ensure that it is in the correct position.

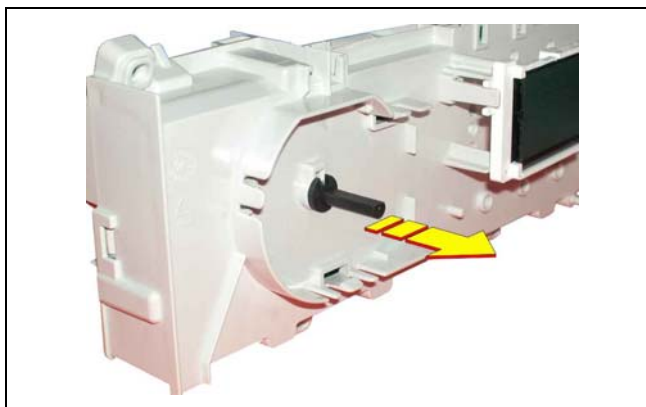

### 11.11.3 Removing the selector dial

- The selector dial can be removed after removing the main circuit board.
- Press the two long sides towards the centre and at the same time push the knob outwards.

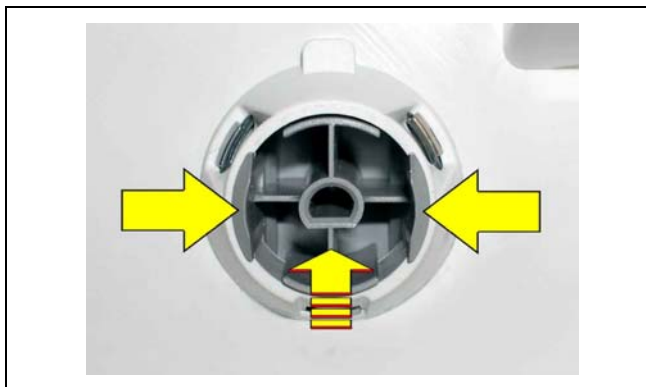

### 11.11.4 Buttons spring

The buttons spring remains attached to the main board support by lateral clips.

## 11.12 Sides

- Loosen the screws that secure the sides to the back panel.
- Loosen the screws that secure the sides to the upper uprights.
- Raise the sides slightly and remove them.

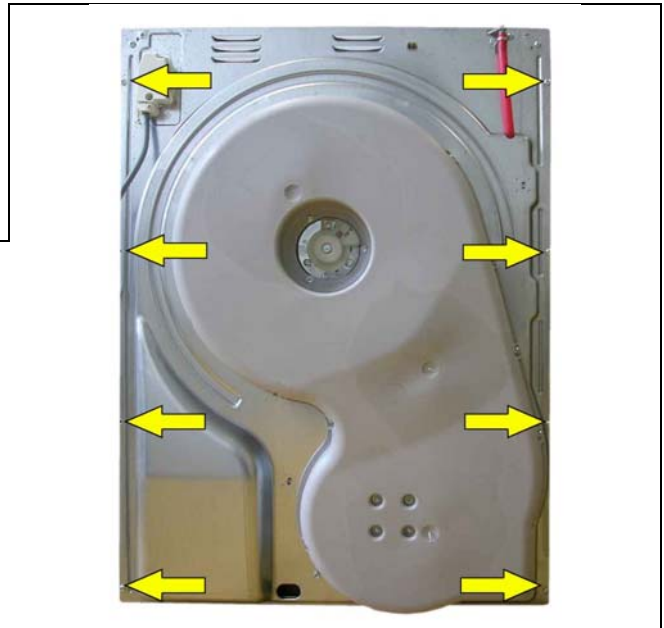

## 11.13 Water conduits

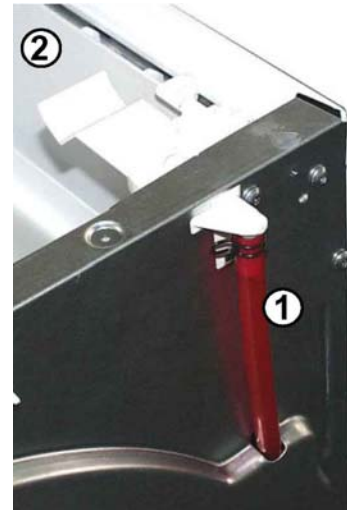
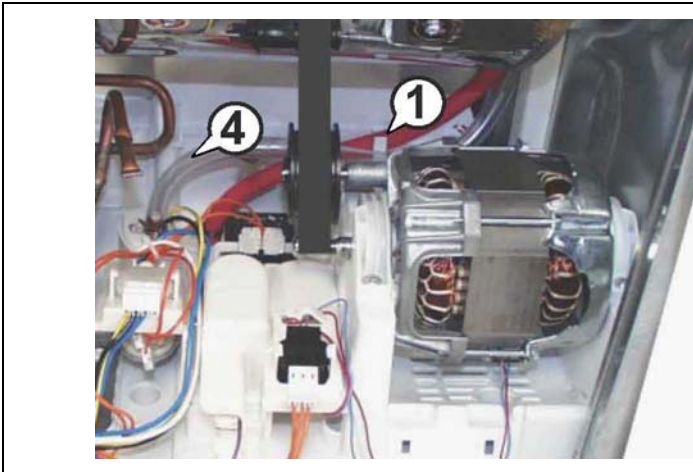

The water conduits can be accessed from the right.

The condensation water is conveyed to the collection tank (2) through the tube (1).

When the tank (2) is full, the water that spills into the tank support (3) returns to the trap through the tube (4).

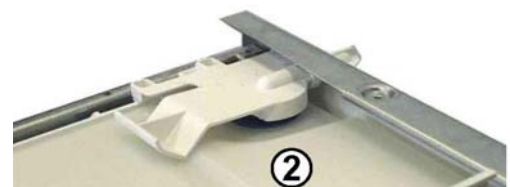
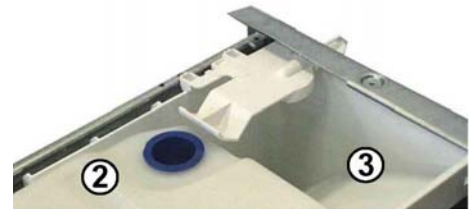

## 11.14 Condensation pump / float switch

The water that has condensed during the drying cycle is collected in a tray (2) which is communicating with the float chamber (8).

The cover assembly (1) is where the pump (3) is fitted, and it is secured to the base using 3 screws (S).

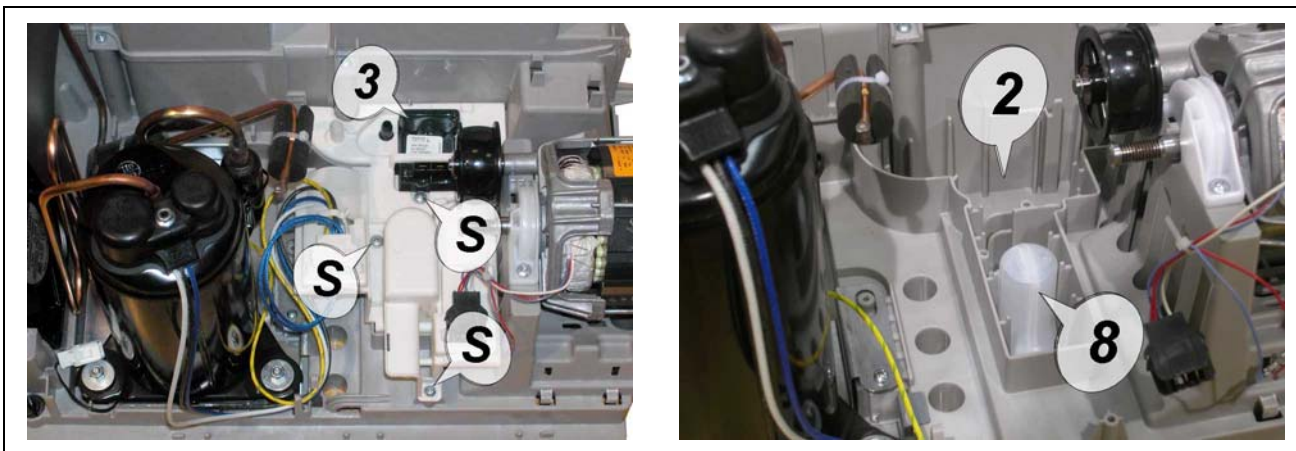

In the cover assembly (1), in addition to the pump (3), the running capacitor (C) of the compressor motor and of the drum rotation motor are secured there. The float micro-switch (5) is also housed there.

### 11.14.1 Pump

To remove the pump (3), remove the assembly (1), disconnect the pump wiring, and with the aid of a screwdriver, remove the pump which is clicked into place.

### 11.14.2 Float micro-switch

The float micro-switch (5) is secured beneath the cover assembly using screws.



When repositioning the cover assembly, pay special attention to ensuring the float can move correctly.

## 11.15 Drum rotation motor

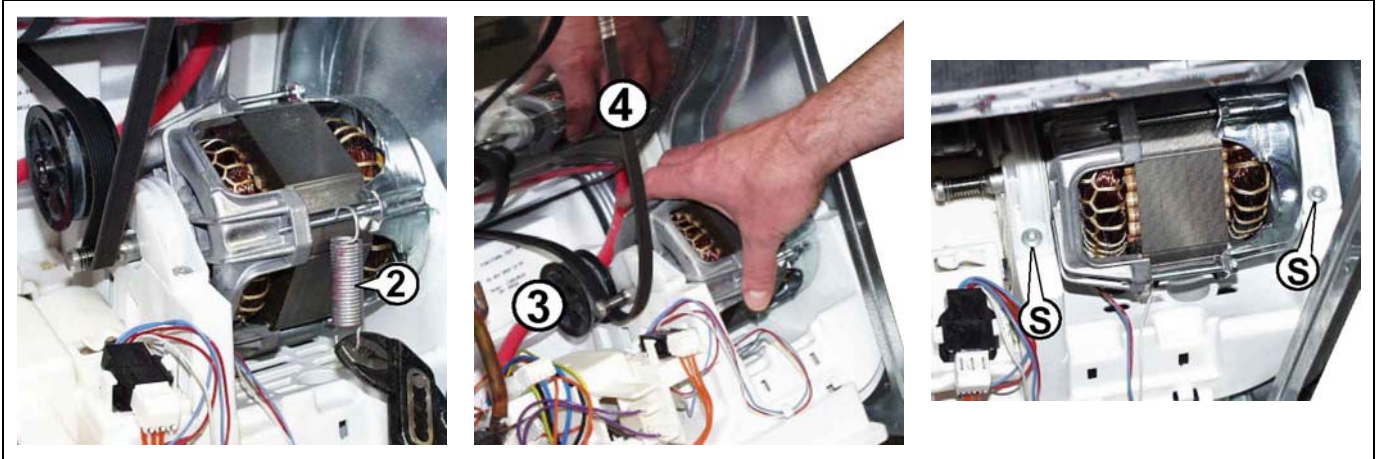

- Release the belt tensioner spring (2). This loosens the belt tensioning roller (3), which is secured to the motor.
- Turn the motor towards the inside of the dryer. This loosens the belt (4), which can then be removed.
- Loosen the screws (S) used to secure the front and rear motor brackets (5), rotate them by approximately 90° and remove them.

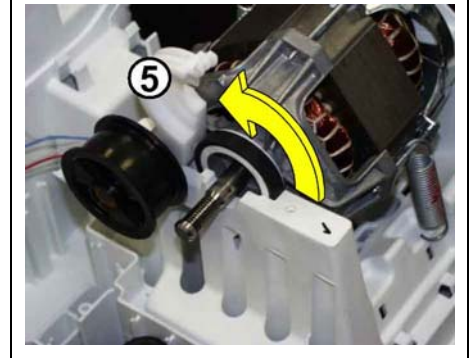

### WARNING

In some models, there may be a plastic spacer between the rear bush and the motor. During assembly, take care you reposition it correctly.

## 11.16 Heat pump circuit NTC



The NTC (1) is housed in a purpose-provided pocket situated beside the dehydrating filter (3) in the heat pump circuit between the capacitor and the evaporator. A purpose-provided spring (2) ensures the NTC is secured in place.

- To remove it, press the spring so that it is released from the bottom, and remove the NTC.

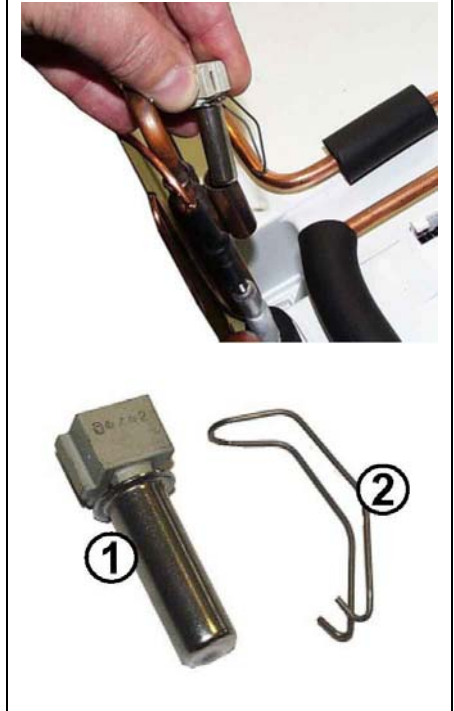

## 11.17 Conductivity circuit brushes

### 11.17.1 Drum brush

The carbon drum brush (1) is positioned above the base in a purpose-provided seat.

- Disconnect the electrical connection
- Lower the two clips (2) and pull it out.

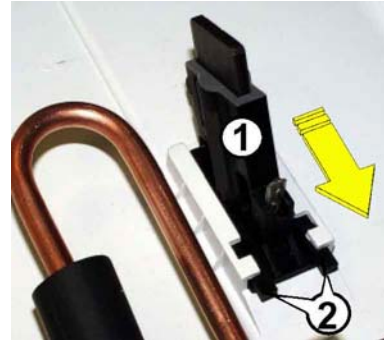

### 11.17.2 Rear brush

Unfasten the screw fixing the drum pin guard.

Turn the guard until the lower fixing clip is free.  
The brush is housed inside the drum pin guard.

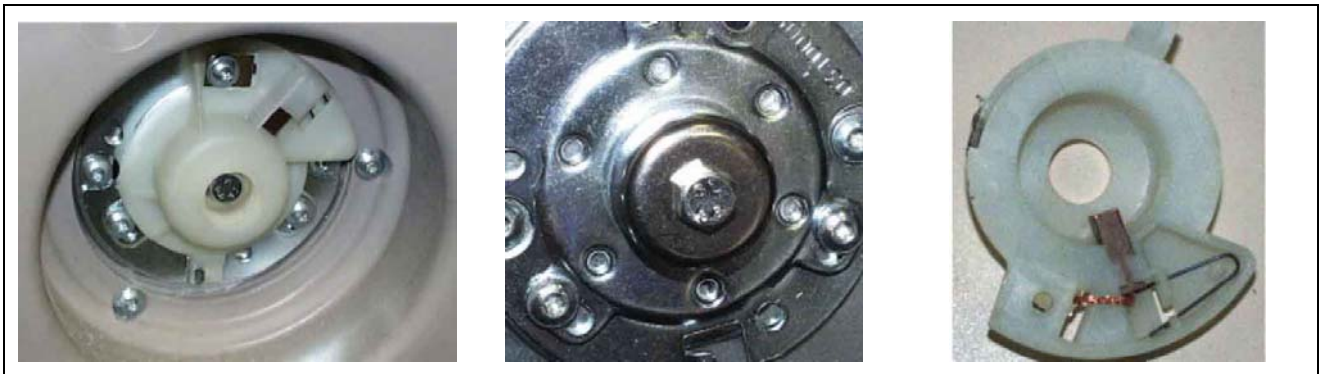



## 11.18 Rear air channel

- Disconnect the power fan connector (2).
  - Loosen the 18 screws that secure the air channel to the back panel, taking care to to loosen the 4 screws (1) which secure the power fan in place.
  - Release it from the back panel, raising it slightly.
  - Once the back panel has been removed, loosen the 4 screws (1) to remove the power fan as well (6) and divide the 3 parts which make up the rear air channel.
- (3) External cover.  
(4) Isolating pad.  
(5) Internal air channel.

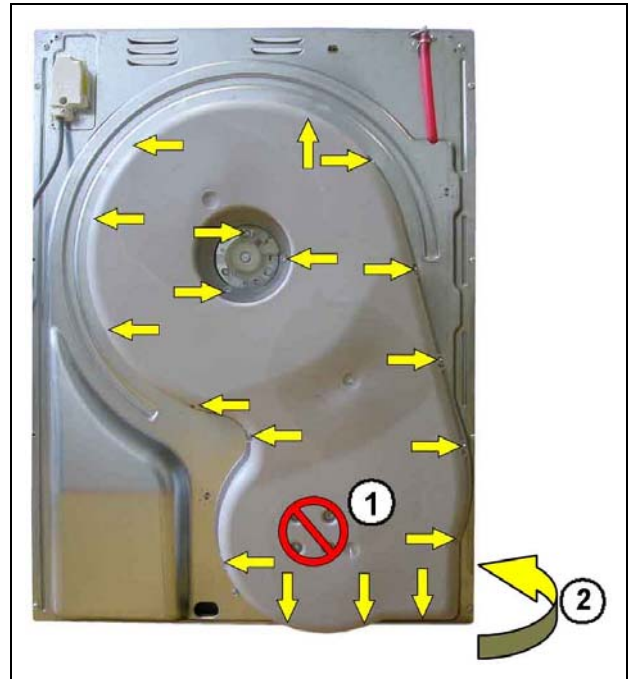

## 11.19 Motor protector

- To reach the thermal motor protection, loosen the screw indicated by the arrow which secures the protective cap.

The thermal motor protection is located inside it (indicated by the arrow), kept in contact with the motor by a spring and the motor contacts.



**WARNING**

Before disconnecting the electrical wires, make a note of their position.



## 11.20 Removing the chassis for servicing

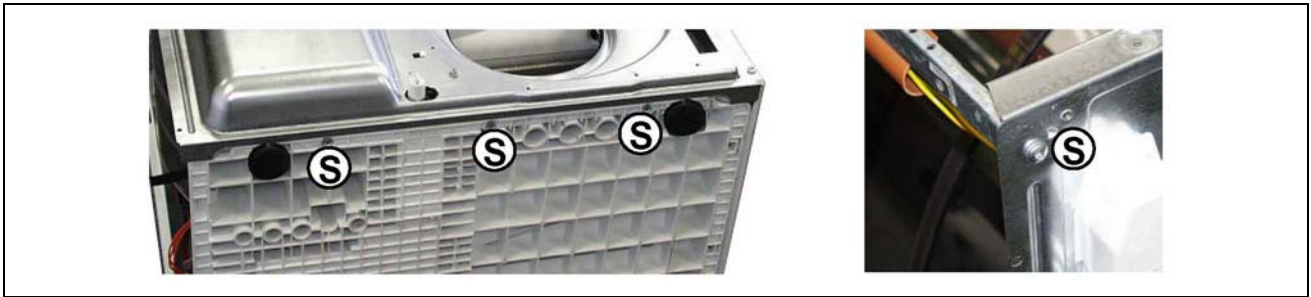

- Remove the sides (see paragraph).
- Disconnect all the wiring affected.
- Remove the belt tensioner spring and loosen the belt.
- Remove the 3 fixing screws (**S**) which secure the back panel to the base.
- Loosen the 2 screws (**S**) which secure the back panel to the 2 upper supports.
- Remove the red condensation tube.

After the back panel and drum have been removed, all the electrical parts fitted to the base can be accessed easily.

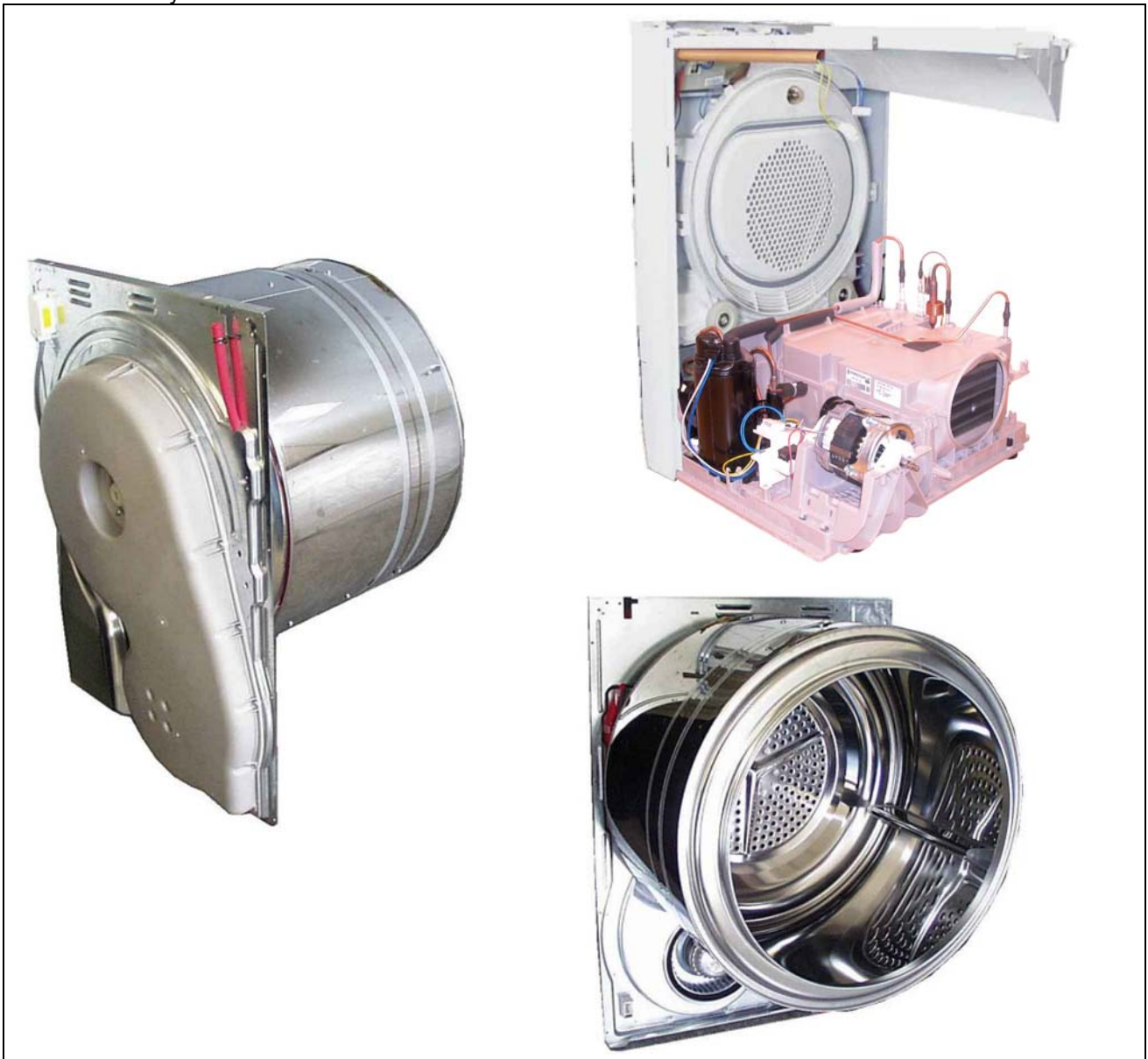

### 11.21 Air conduit

- Take out the drum (see paragraph).
- Loosen the screws that secure the hinges and covers to the conduit.
- Unhook any wiring.
- Remove the conduit.

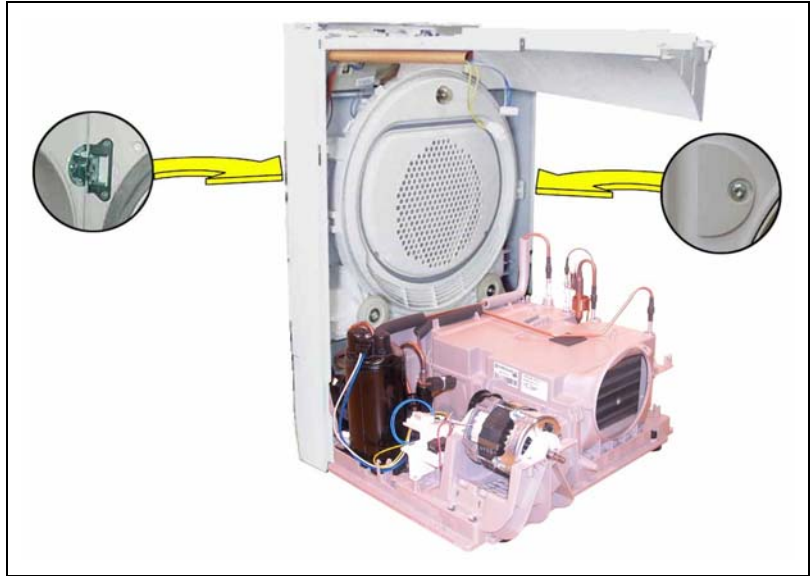

### 11.22 Front air seal

Once the drum has been removed, the front air seal can be removed.

- Pull out the air seal from its seat.

When repositioning it, make sure the joint marked in red is positioned at the bottom.

### 11.23 Conduit rollers

Once the drum has been removed, the conduit rollers can be removed.

- Loosen the screw that secures them and remove them.



#### **WARNING**

*Never take out the rollers without removing the drum first!  
This could cause irreparable damage to the air conduit.*

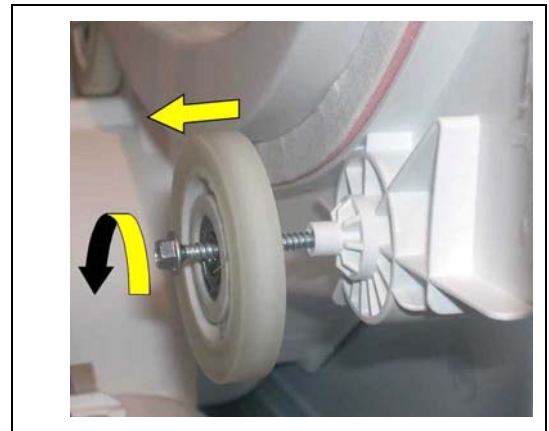

## 11.24 Rear air seal

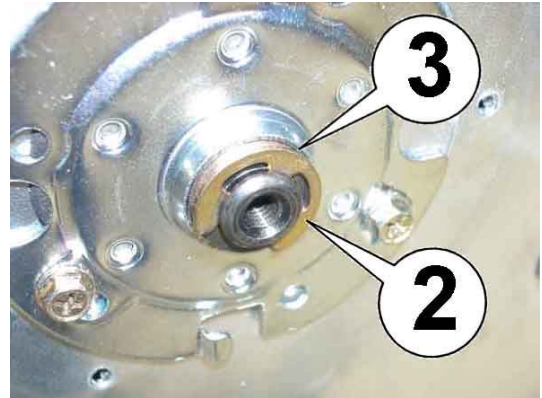

- Remove the worktop (see paragraph).
- Remove the sides (see paragraph).
- Release the belt tensioner spring.
- Disconnect the connectors from the main terminal board.
- Remove the rear brush (see paragraph).
- Remove the screw (1) that secures the bush.
- Pull out the snap ring (2) from the spacing washer (3).
- Loosen the screws that secure the back panel to the crossbars and to the base and remove the back panel.
- Pull out the seal from its seat.

When fitting the new seal, take care to ensure that the seam is located in the lower part of the ring.



## 11.25 Checking the heat pump performance

To check the correct functioning of the heat pump, position the sensors in the points indicated and compare the graphs with those provided below.

In the event of significant variations, the presence of a fault is likely.

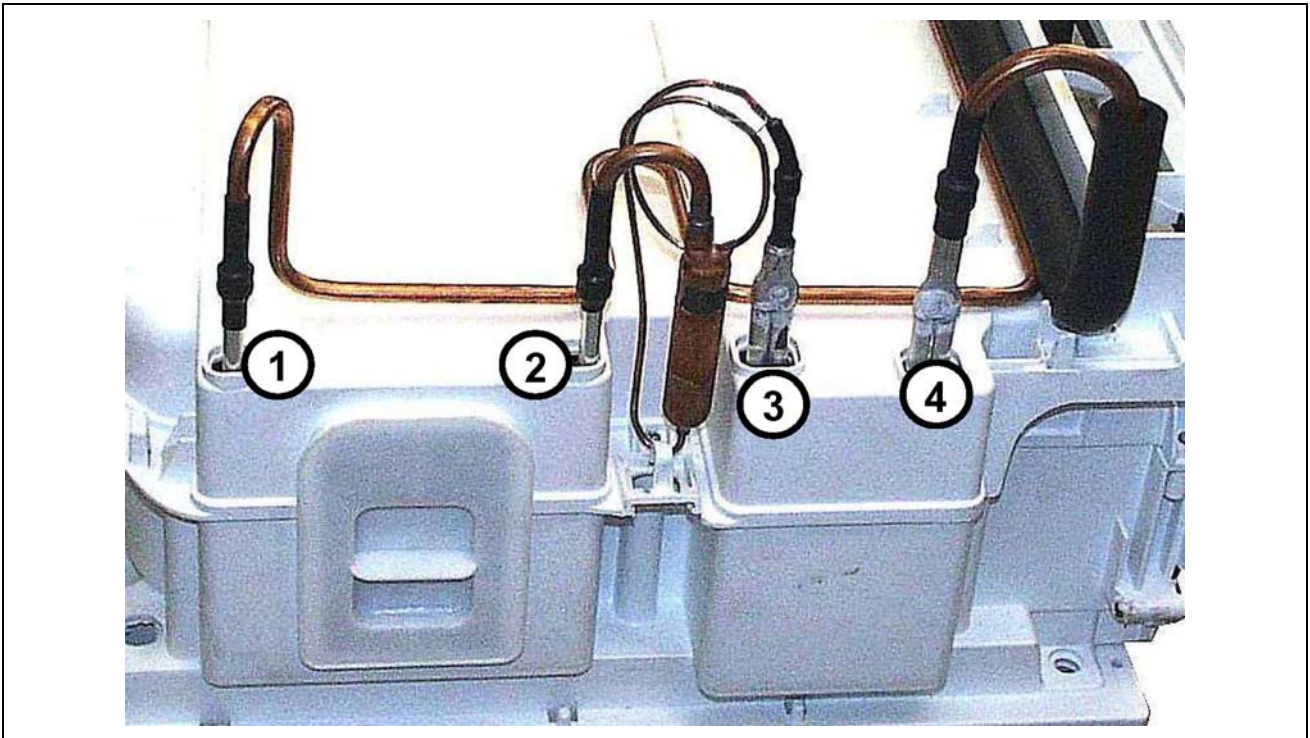

1 Capacitor inlet  
2 Capacitor outlet

3 Evaporator inlet  
4 Evaporator outlet

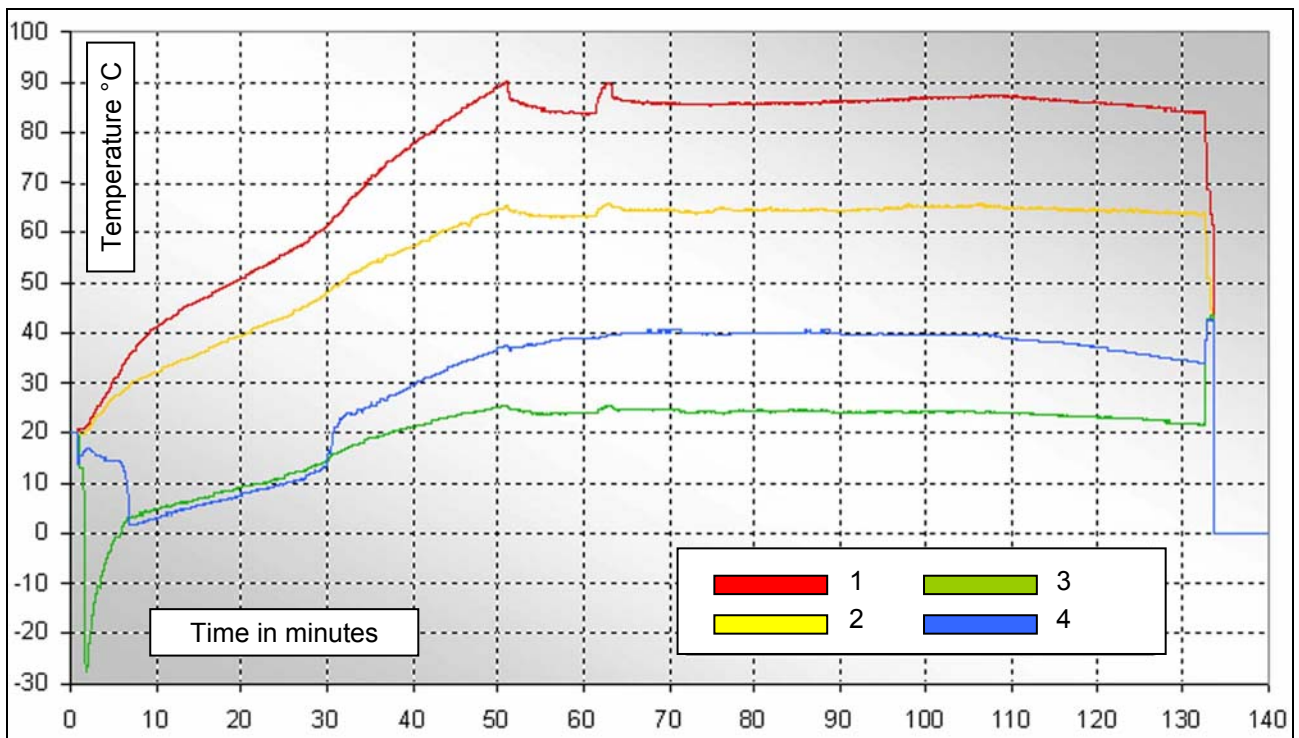

## 11.26 Servicing the heat pump circuit

### 11.26.1 Compressor replacement



**The circuit is evacuated with the compressor switched off.**

- Disconnect the appliance from the power supply.
- Evacuate the gas by inserting the purpose-provided pin valve (1).
- Dispose of the R134a refrigerant fluid in compliance with local provisions.
- Loosen the compressor from its seat to facilitate access.
- Cut the suction and supply conduit using a cutter.
- The compressor can now be replaced.

- Then connect the supply and suction conduit to the circuit using LOCKRING fittings.

A Schrader valve (4) can be fitted to the suction conduit to empty and fill the heat pump circuit.

Alternatively, a separate filling pipe union with valve (6) can be connected to the compressor's existing filling tube.

- Evacuation should take 15 minutes and should only be performed on the suction side.
- During the evacuation cycle, the compressor will need to be shaken at least once to release as much gas as possible still combined with the oil.

By doing so, as much gas and humidity as possible will be removed from the cooling circuit.



### 11.26.2 Filling

The refrigerant fluid can be topped up directly from the bottle using purpose-provided scales (7).

R134a refrigerant fluid is supplied in disposable bottles.

During filling, the compressors must be switched off and the serviceman must wear appropriate protection devices.

R134a 270g



## 11.27 Door reversibility

- Open the door.
- Remove the door by loosening the two screws situated on the front, which secure the hinges (A) to the appliance.
- Remove the covers (B) and (C) prying them off with a thin screwdriver.
- Remove the door fastening latch (D) using a screwdriver to push it and use it on the opposite side, after turning it by 180° (upside down).
- Unscrew the hinges (A) and use them on the opposite side, after turning them by 180°.

Reposition the covers (B) and (C) on the opposite side, after turning them by 180° so as to cover the remaining slots.

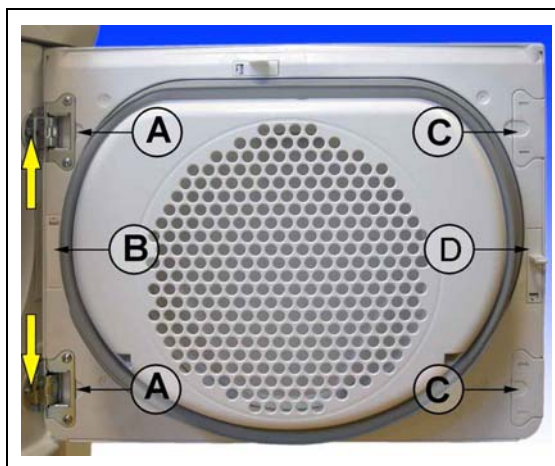

- Loosen the 2 covers (E) on the front, turn them by 180° and reposition them on the opposite side.

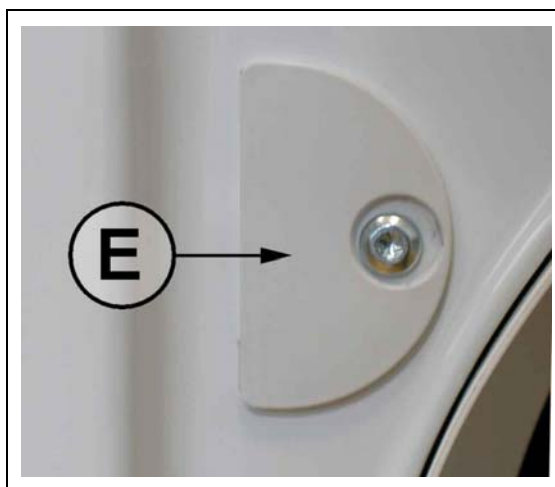

- Unscrew the door latch (F), push it down slightly and remove it, turning it slightly downwards.
- Press the retainer hook of the cover (G) and at the same time push it down.
- Transfer the door lock (F) to the opposite side and secure it using the screws you previously removed.
- Transfer the cover (F) to the opposite side, making sure the hook is correctly inserted into the slot.
- Reposition the door with the hinges on the opposite side. Lock the fixing screws tightly and check that it operates correctly.

