

<p>©ELECTROLUX Italia S.p.A. Corso Lino Zanussi, 30 I - 33080 Porcia / PN (Italy)</p> <p>Fax: + 39 0434 394096</p> <p>Edition: 01 / 2010</p>	<p>Ventilated tumble dryer with electronic control</p> <p>ENV06</p>	

Publication No

599 72 63-27

EN

TABLE OF CONTENTS

1	PURPOSE OF THIS MANUAL	5
2	WARNINGS	5
2.1	Installation	5
3	GENERAL CHARACTERISTICS	6
3.1	Circuit boards	6
4	CONTROL PANEL	7
4.1	Programme selector	8
4.2	Buttons	8
4.3	Symbols on control panels with LCD	8
4.4	Delicate programme	9
4.5	Cotton and synthetics cycles (on certain models only)	10
4.6	Long anti-crease cycle (on certain models only)	10
4.7	Enabling and disabling the buzzer	11
4.8	Time programme (on certain models only)	11
4.9	Delay start	12
4.10	Child lock (on certain models only)	12
4.11	START / PAUSE button	13
4.12	Adjusting conductivity (on certain models only)	14
4.12.1	Adjustment procedure	14
4.12.2	Indications displayed	15
4.13	End of cycle	16
5	How to operate the appliance	17
5.1	How a cycle works	17
5.2	Operation in PAUSE mode	17
5.3	Opening the door	18
5.4	Power failure	18
6	OPERATING CHARACTERISTICS AND CONSTRUCTION	19
6.1	Operating principle	19
6.2	Construction	20
6.3	Drum	20
6.4	Air seals and drum pin support	21
6.5	DRUM ROTATION MECHANISM	21
7	ELECTRICAL COMPONENTS	22
7.1	Electronic control	22
7.1.1	Main circuit board functions	22
7.1.2	Electronic control memories: general structure	23
7.2	Conductivity sensor	25
7.3	Junction box with integrated anti-disturbance filter	25
7.4	Heating unit	26
7.5	NTC probe	26
7.6	MOTOR UNIT	27
7.7	Door lock with door microswitch incorporated	28
7.8	Door lock without door microswitch incorporated	29
7.9	Door microswitch	29
8	WIRING DIAGRAMS	30
8.1	Wiring diagram for tumble dryers with conductivity sensor	30
8.2	Wiring diagram for tumble dryers with temperature probe	31
9	DIAGNOSTIC SYSTEM	32
9.1	Accessing diagnostics	32
9.2	Quitting the diagnostics system	32
9.3	Diagnostic test phases	33
10	ALARMS	35
10.1	Displaying user alarms	35
10.2	Viewing alarms during normal operation	35
10.3	Reading the alarms	35
10.4	Displaying the alarm on all models	35
10.4.1	Viewing any other alarms	35
10.5	Deleting the last alarm	36
10.6	Notes on the behaviour of certain alarms	36
11	Alarm Summary Table	37
12	CANNOT ACCESS THE DIAGNOSTICS PROGRAMME	39
13	ACCESS TO COMPONENTS	40

13.1	Door	40
13.2	Door fastening latch	40
13.3	Door lock	41
13.3.1	AEG model door lock	41
13.3.2	EMZ model door lock with fitted microswitch	41
13.4	Door microswitch latch (certain models only)	42
13.5	Door microswitch (certain models only)	42
13.6	Fluff filter	43
13.7	Drum lamp	43
13.8	Worktop	44
13.9	Control panel	44
13.10	Main circuit board	45
13.10.1	Removing the board	45
13.10.2	Removing the selector pin	45
13.10.3	Removing the selector dial	45
13.10.4	Buttons and button springs	45
13.11	Back panel cover	46
13.12	Heating unit	47
13.13	Anti-disturbance filter	47
13.14	Sides	48
13.15	NTC probe	49
13.16	Running capacitor	49
13.17	Motor/fan assembly	50
13.17.1	Notes for reassembly of the belt tensioning roller / belt	50
13.18	Rear brush (only on models with conductivity sensor)	51
13.19	Front brush (only on models with conductivity sensor)	51
13.20	Back panel	52
13.21	Belt	53
13.22	Drum	53
13.23	Conduit rollers	53
13.24	Rear air seal	54
13.25	Front air seal	54
14	REVERSING THE DOOR	55
15	Final testing of door fastening	57

1 PURPOSE OF THIS MANUAL

The purpose of this manual is to provide technicians (who already have the basic skills required to carry out repairs on tumble dryers) with technical information on this condensation tumble dryer with electronic control.

The electronic control is made up of a main circuit board with integrated selector - certain models have an LCD display. They are supplied ready-assembled and tested by the manufacturer.

The manual deals with the following topics:

- General characteristics.
- Control panel and drying programmes.
- Description of operation.
- Drying circuit.
- Electrical components and wiring diagram.
- Guide to diagnostics.
- Alarms.
- Access.

2 WARNINGS

 <p>ATTENZIONE</p>	<p>⇒ Any work on electrical appliances must only be carried out by qualified technicians.</p> <p>⇒ Before accessing internal parts of the appliance, always make sure the plug has been removed from the power socket.</p>
--	--

2.1 Installation

The appliance must be installed so that it is perfectly level (using a spirit level).

The feet must never be removed. A gap must always be left between the bottom of the tumble dryer and the floor to prevent the appliance from overheating.

3 GENERAL CHARACTERISTICS

Dimensions of appliance	<ul style="list-style-type: none"> ▪ Height: 85 cm ▪ Width: 60 cm ▪ Depth: 58 cm
Supply voltage	<ul style="list-style-type: none"> ▪ Volts: 220-240 ▪ Hz: 50/60
No. buttons	▪ Depends on model
No. LEDs	▪ Depends on model
Type of display *	▪ LCD
Buzzer	▪ buzzer integrated in the circuit board
Serial port	▪ DAAS-EAP communication protocol up to 230400 baud
Programme selector	▪ 15 / 25 positions With integrated ON/OFF switch
Drying system	▪ damp condensation with heat exchanger
Humidity control *	▪ conductivity sensor
Motor	▪ capacitor-run asynchronous monophase motor
Heating unit power	▪ 220-240V 2200 W version 1400 W + 800 W
Temperature control	▪ NTC probe

* Only models with conductivity meter.

3.1 Circuit boards

The electronic control is made up of a main circuit board with integrated selector and on certain models LCD display, which are supplied ready-assembled and tested by the manufacturer.

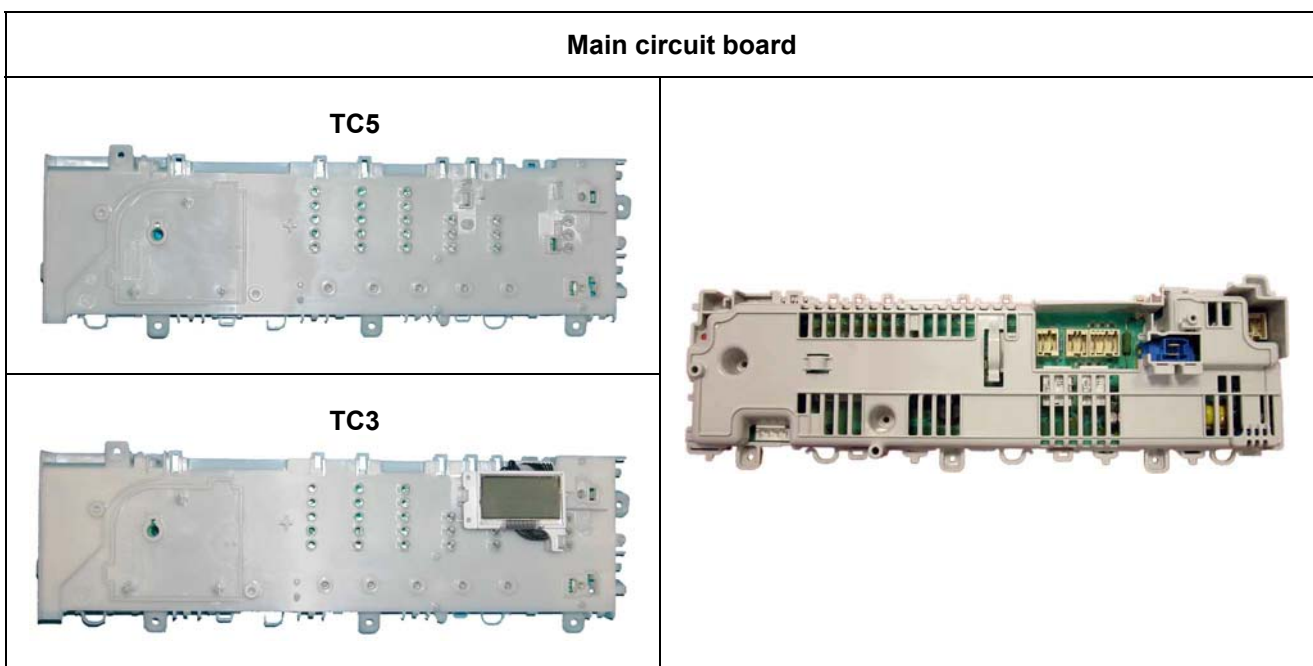

4 CONTROL PANEL

The shape of the control panel varies according to the number of buttons and LEDs used.

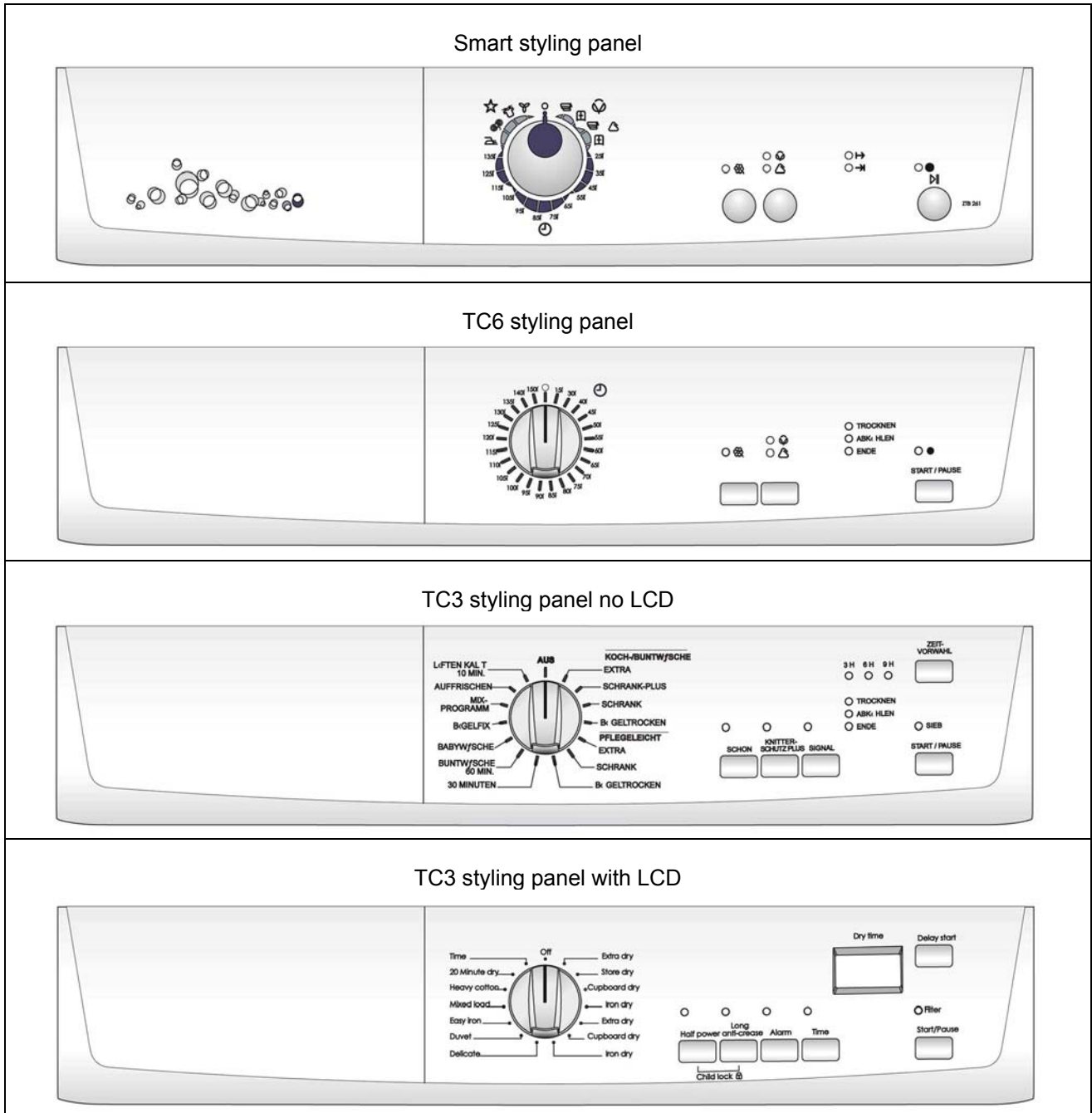

4.1 Programme selector

The 15 / 21 / 25 position selector dial (with integrated ON/OFF switch) forms an integral part of the board.

The symbols represent the various drying options for the various fabric types.
COTTON, SYNTHETIC, SILK, WOOL and TIMER.
All positions can be configured, according to the mode



4.2 Buttons

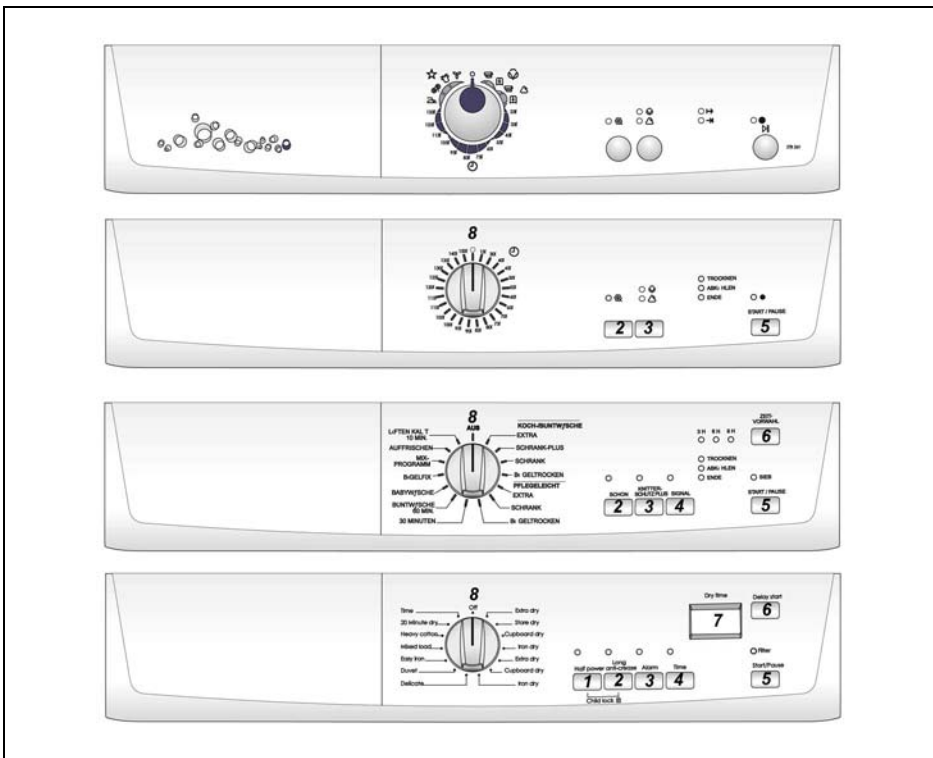

1. Configurable button
2. Configurable button
3. Configurable button
4. Configurable button
5. Start / Pause button
6. Delay start button
7. LCD
8. Programme selector

4.3 Symbols on control panels with LCD



Time remaining
Error message

Child lock

Delay start set

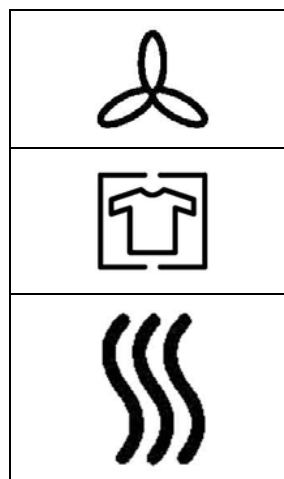

Cooling phase

Anti-crease cycle

Drying phase

4.4 Delicate programme

When this button is pressed only one branch of the heating element is turned on, so that drying takes place at a lower temperature that is ideal for delicate garments.

The corresponding indicator light turns on.

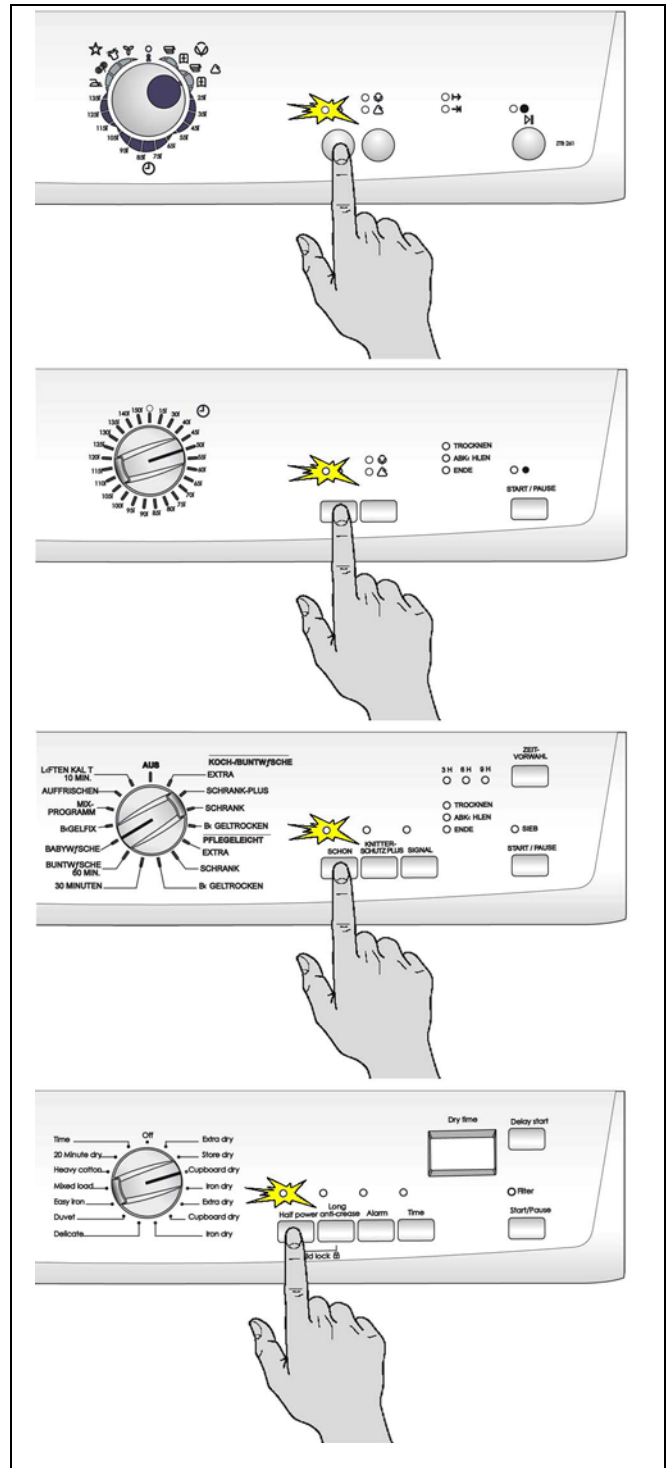

4.5 Cotton and synthetics cycles (on certain models only)

Press this button to select the fabric type placed in the tumble dryer.

When the option cotton fabric is selected, the relevant LED lights up and the clothes are dried at a constant temperature just under the maximum temperature.

When the option synthetic fabric is selected, the relevant LED lights up and the clothes are dried at a constant temperature that is much lower than the maximum temperature.

If no option is selected, none of the LEDs will light up and the clothes will be dried at maximum temperature.

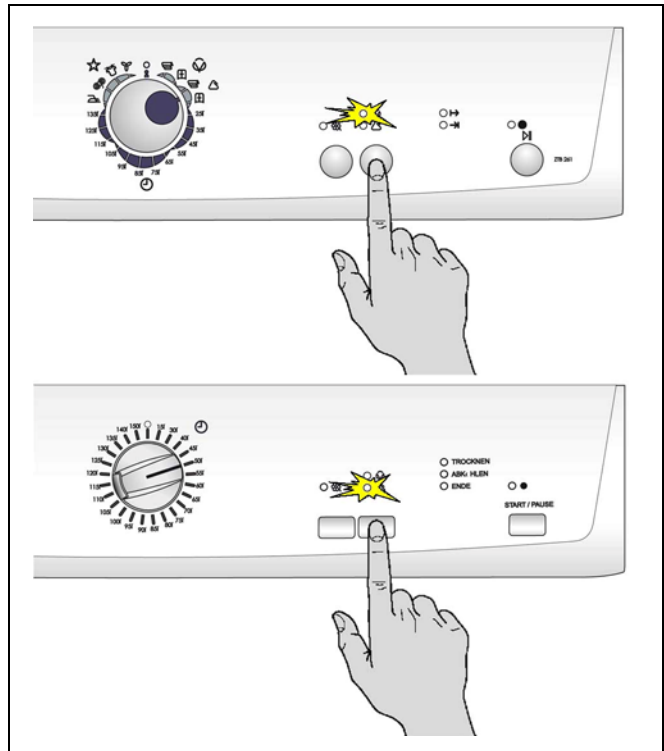

4.6 Long anti-crease cycle (on certain models only)

This option extends the normal anti-crease time (30 min.) at the end of the drying time by a further 60 minutes.

During this phase the drum turns at intervals. This ensures that the washing remains soft and free from creases.

This phase lasts for a total of 90 minutes.

The washing can be removed from the drum at any time during the anti-crease phase.

When this option is enabled, the corresponding indicator light KNITTERSCHUTZ PLUS (Long anti-crease) lights up.

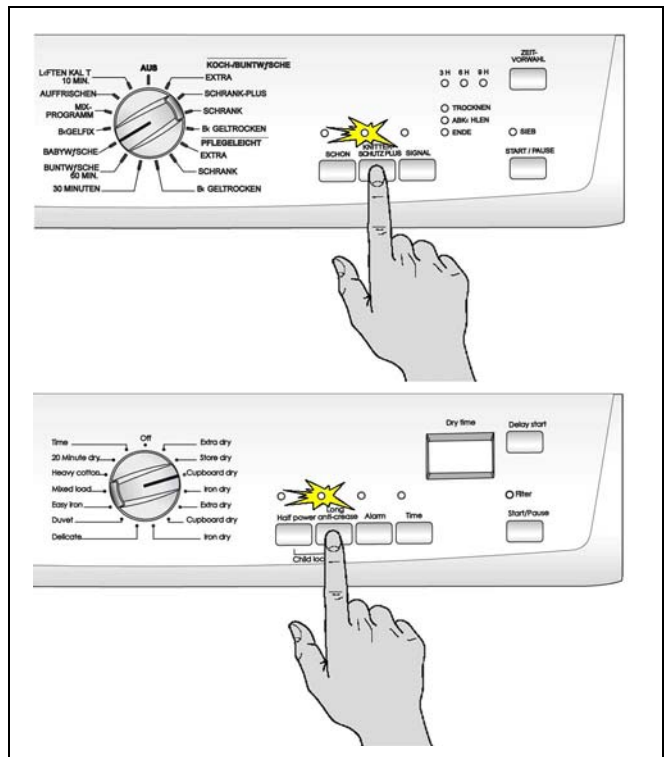

4.7 Enabling and disabling the buzzer

At the end of the drying cycle or if an alarm is triggered the buzzer will sound intermittently.

When the ALARM button is pressed, the corresponding indicator light goes out and the buzzer is deactivated in the following cases:

- when the programme is selected;
- when the buttons are pressed;
- when the programme selector is turned to another position during the programme, or when an option button is pressed during the cycle;
- at the end of the programme.

In all other cases the buzzer remains active.

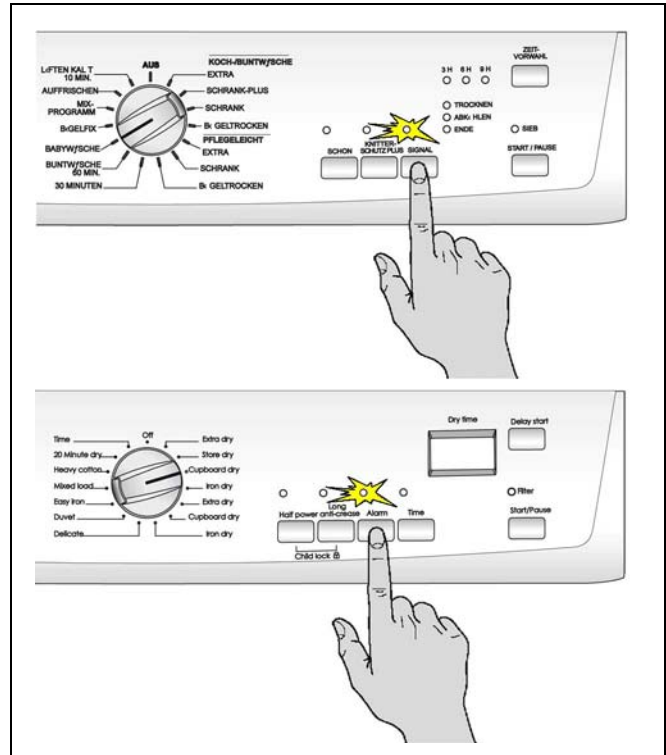

4.8 Time programme (on certain models only)

Use the TIME programme to select drying for a customised length of time.

After selecting the programme, you can select its duration: options range from 10 minutes to 3 hours, with 10 minute increments.

- Turn the programme selector to the programme TIME.
- Press the TIME button repeatedly until the length of time you require is shown on the display.

If the length of time is not selected, the programme will set automatically to 10 minutes.

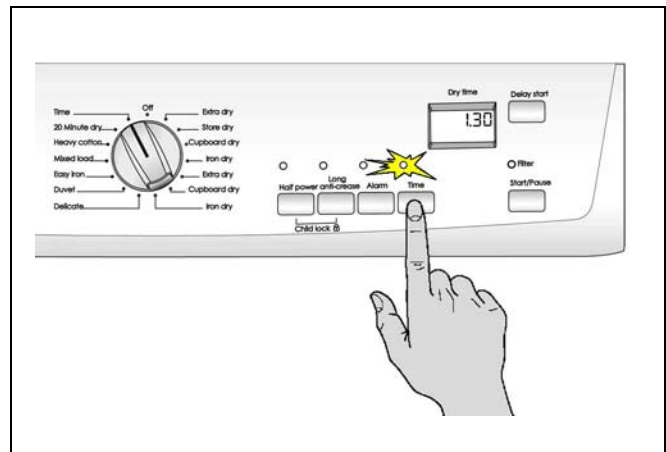

4.9 Delay start

The delay start button can be used to delay the start of the programme from 30 minutes (30') to a maximum of 20 hours (20h) in models with LCD, and to delay the start of the programme from 3 to 9 hours in models without an LCD.

Activation

- Select the programme and any additional functions.
- Press the Delay start button until the required LED lights up, or until the delay required is shown on the display, according to model.

To activate the delayed start, press the START/PAUSE button, the display will show the time remaining until start of the programme (e.g. 15h, 14h, 13h, ... 30' and so on).

Deactivation

- To deactivate delayed start, press the Delay start button repeatedly until the time reaches zero, or turn the programme selector dial.

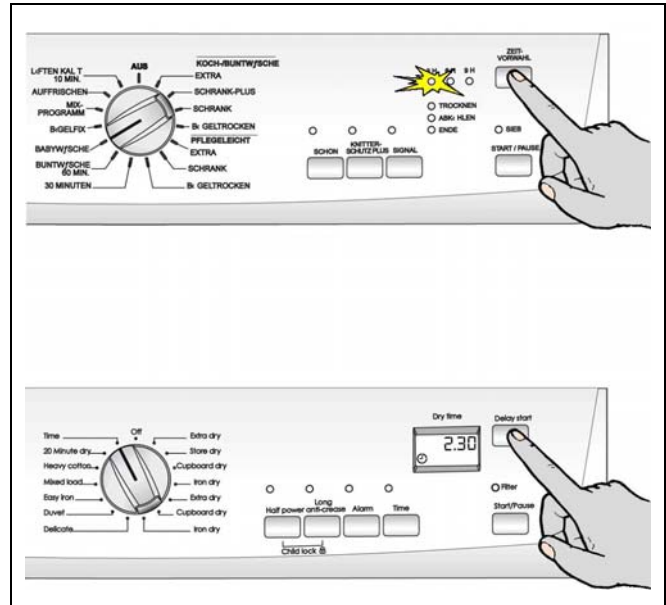

4.10 Child lock (on certain models only)

To prevent a programme from being started or changed by accident, it is possible to set a child lock.

This function enables all buttons and the programme dial to be locked.

To enable or disable this function, press the delicate cycle button and the long anti-crease cycle button simultaneously, and hold for 5 seconds.

- Before starting the programme: the appliance cannot be used.
- After the programme has started: the selected programme cannot be changed.

The display shows the symbol indicating that the child lock has been enabled.

The child lock device does not deactivate at the end of the programme.

In order to start a new programme, the child lock must first be deactivated by pressing the buttons once again as described above.

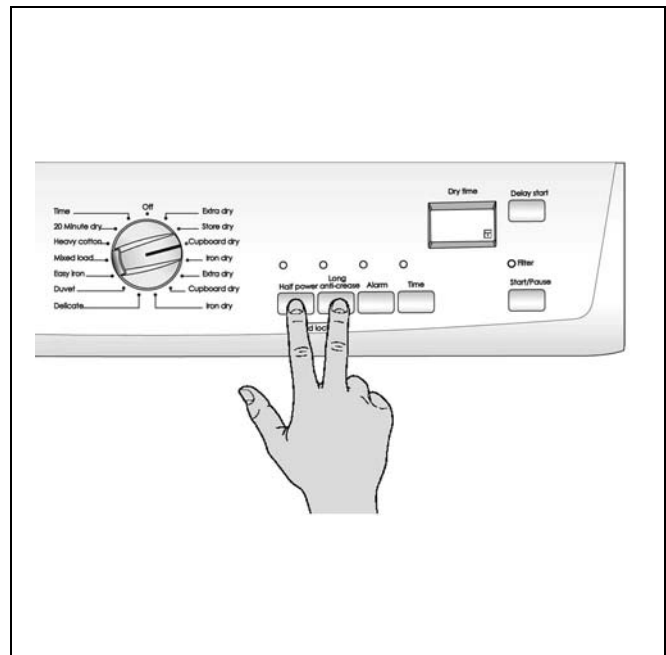

4.11 START / PAUSE button

After the START / PAUSE button has been pressed, the programme will start.

On models with LCD the drying, anti-crease and cooling phases are indicated from left to right, and in models without LCD the LEDs light up from the top downwards.

On some models without LCD only the drying phase and the end of cycle are shown.

Changing the programme

To change a programme that has been selected by mistake once it has started, first turn the programme dial to 0 (OFF) and then select the new programme.

Once a programme has started, it cannot be changed directly.

Any attempt to change the programme using the selector or a function button will cause the indicator light over the START / PAUSE button to flash and the buzzer will emit a series of sounds, but the programme itself will not be changed in any way.

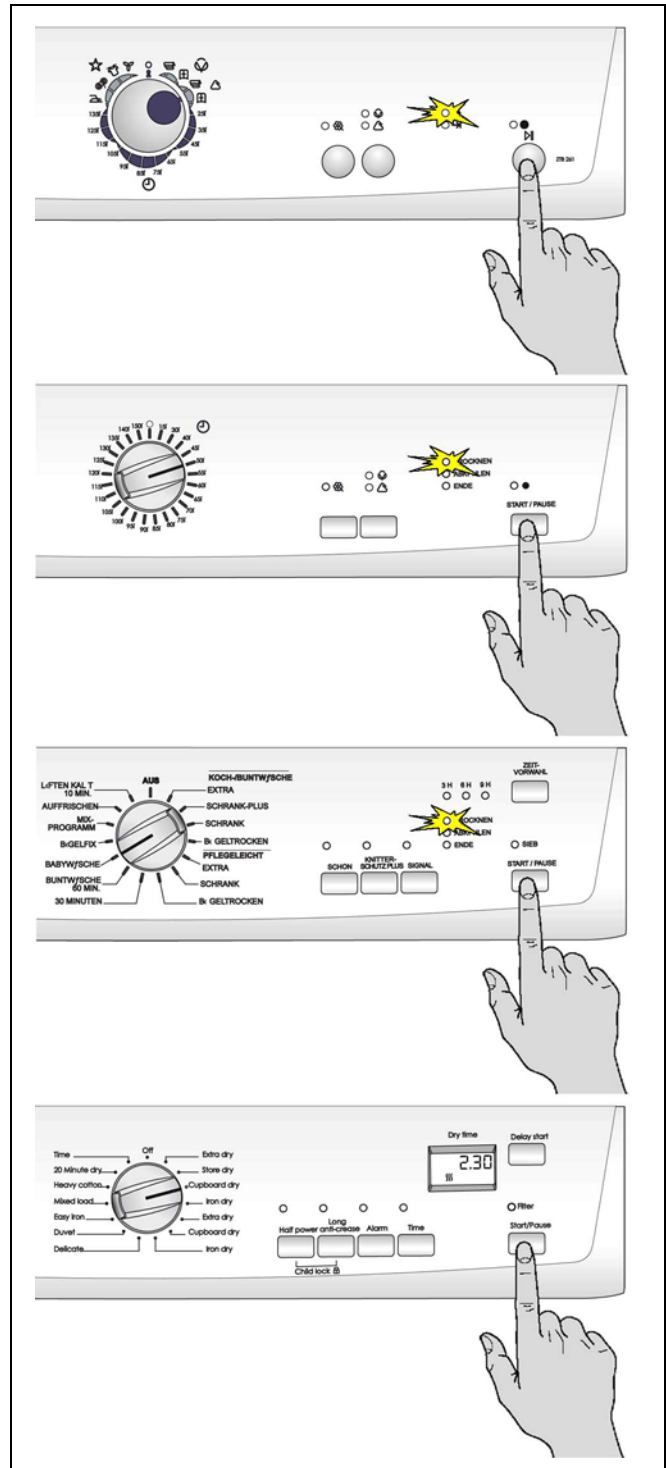

4.12 Adjusting conductivity (on certain models only)

The "conductivity" of the water used for washing varies from area to area: the conductivity sensor is set to a standard value; significant variations in conductivity level may have a negative effect on the final results of drying (washing that is too dry or still damp).

These variations can be noted particularly in "slightly damp" and "ready-to-iron" cycles; "wardrobe dry" cycles are practically never influenced by changes in conductivity.

4.12.1 Adjustment procedure

To access adjustment mode:

1. turn the appliance on by turning the programme selector;
2. press the buttons shown in the figure simultaneously;
3. keep pressing them until the buzzer sounds (about 5 seconds).

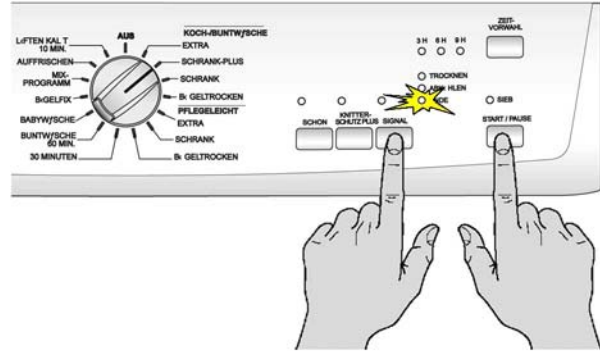

To change the conductivity value:

press the start/pause button in sequence: the conductivity level changes and is indicated by light-up of the LEDs or by light-up of the horizontal segments in the last digit.

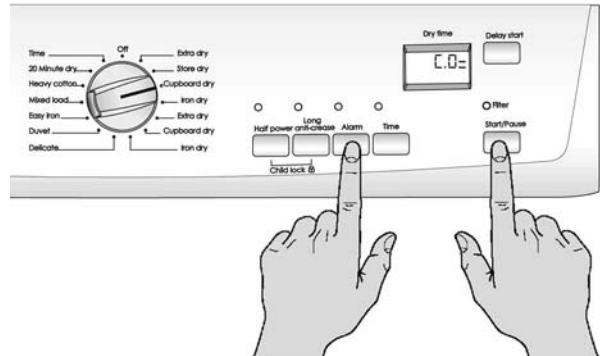

To store the setting:

1. press the buttons you pressed before once again, simultaneously;
2. keep pressing them until the buzzer sounds (about 5 seconds).

4.12.2 Indications displayed

Display / LED	Conductivity level	Approximate value (µS/cm)
DISPLAY LED	LOW	< 300
DISPLAY LED	MEDIUM	300 – 600
DISPLAY LED	HIGH	> 600

The normal factory setting is medium level, but some models may have a different configuration.

Ask your local water board for details of the conductivity level of your water supply.

4.13 End of cycle

Once the drying cycle has ended, on machines with LCD the value " 0 " and the clean filter LED will flash.

In models not fitted with an LCD the end of cycle is indicated by the fact that the END led and the FILTER led start to flash.

In all models, if the buzzer has been activated, the buzzer will sound intermittently for about one minute.

Drying cycles are automatically followed by an anti-crease phase, which lasts approximately 30 minutes.

During this phase the drum turns at intervals to ensure that the washing remains soft and crease-free.

The washing can be removed from the drum at any time during the anti-crease phase.

To avoid the formation of creases, it is recommended that the washing only be removed at the end of the anti-crease phase.

If the Long anti-crease function has been selected, the anti-crease phase is extended by a further 60 minutes.

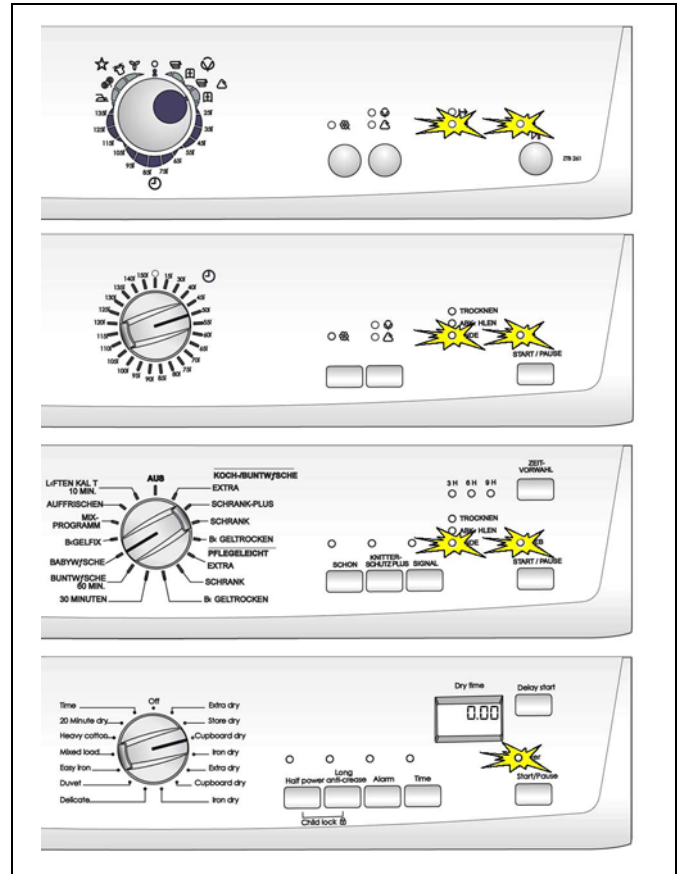

1. Open the door.
2. Remove the washing.
3. Remove the filter and open it as shown in the figure.
4. Clean the filter and if necessary rinse it out with water so as to remove all residual fluff.
5. Turn the programme selector dial to the OFF position.
6. Replace the filter.
7. Close the door.

Caution Before fitting the filter again, check that there is no waste/fluff in the housing.

Important The filter must be cleaned after every drying cycle.

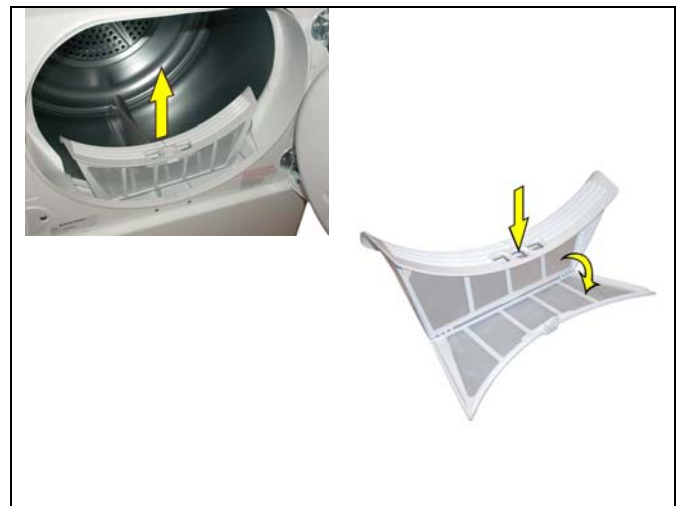

5 How to operate the appliance

When the selector is moved from the OFF position to a drying programme, the LEDs for the drying phases light up and the START/PAUSE led flashes.

The various options can be selected during this phase and the relevant LED will light up.

In models with an LCD the time remaining until the end of the drying cycle is displayed, the first figure indicates the hours, the second and the third indicate the minutes.

If an option that is incompatible with the chosen programme is selected, the Start / Pause LED will flash red three times, the Buzzer will sound and in models with LCD the Display will show Err .

When one or more options are selected, the Display will show an increase or a decrease in the drying time. If the option DELICATE or SENSITIVE is selected, an increase in the drying time will be seen on the display.

If the position of the selector is changed after the options have been selected, but before the START/PAUSE button has been pressed, the options will be reset.

5.1 How a cycle works

A drying cycle starts after a drying programme has been chosen using the selector, any options have been selected, and the START/PAUSE button has been pressed.

The LED for the START/PAUSE button will remain lit and at the same time the LED or icon relating to the phase in progress will light up, while the Display will show the maximum drying time.

A drying cycle is made up of the phases described below.

- **DRYING**

If the cycle is automatic the duration will depend on the amount of time required to decrease humidity to the level indicated for the cycle. This time also varies according to the humidity level detected by the conductivity sensor during the drying phase.

If the cycle has a set time, the duration will depend on the time set, and will not take into account the values detected by the conductivity sensor.

- **COOLING**

This has a maximum duration of 5 minutes for timed cycles, whereas for automatic ones it may be less, according to the temperature inside the drum.

- **ANTI-CREASE**

This has a duration of 30 minutes which can be extended to 90 minutes if the LONG ANTI-CREASE option is selected.

The programme cannot be changed after the drying programme has started.

If the position of the selector is changed, the Start/Pause LED and the buzzer will indicate that this operation is not possible, and the Display will show the message Err.

If any of the buttons are pressed, the Start/Pause LED and the buzzer will indicate that this operation is not possible, and the Display will show the message Err.

The options can only be entered after a drying program has been selected and the selector is positioned at the start of the cycle, or during a cycle after first pressing the START/PAUSE button.

To reset a drying cycle the selector must be turned to the OFF position.

5.2 Operation in PAUSE mode

If a drying cycle is running, when the START/PAUSE button is pressed the tumble dryer stops the cycle in progress, the relevant LED flashes and the display indicates the time remaining until the end of the cycle.

If the selector is turned, all the LEDs flash three times and the buzzer sounds to indicate that this operation is not allowed.

Only certain options can be changed in this mode.

If you press the button for an option that is not allowed in the current programme, the relevant LED and the Start/Pause LED will flash and the buzzer will sound to indicate that the operation is not allowed. The display will show the message Err.

When you press the START/PAUSE button again, the drying cycle will recommence from the point at which it stopped.

5.3 Opening the door

If the door is opened the electronic circuit sets the tumble dryer to pause mode and the Start/Pause button LED lights up. No changes of option are allowed.

The following table shows the state of a tumble dryer with the OPEN DOOR option, before and after pressing the option button.

Before opening the door	After opening the door
Selection (set-up)	Selection (set-up)
Drying cycle	Pause
Cycle paused	Pause
Anti-crease cycle	Selection (set-up)
Delay start	Delay start paused
Delay start paused	Delay start paused
End of cycle	Selection (set-up)

5.4 Power failure

The following table shows how the tumble dryer reacts in the event of a power failure during a drying cycle.

<i>Before the power failure</i>	<i>After the power failure</i>
Selection (set-up)	Selection (set-up)
Drying cycle	Pause
Cycle paused	Pause
Anti-crease cycle	End of cycle
Delay start cycle	Delay start cycle paused
Delay start cycle paused	Delay start cycle paused
End of cycle	End of cycle

6 OPERATING CHARACTERISTICS AND CONSTRUCTION

6.1 Operating principle

FIG 1

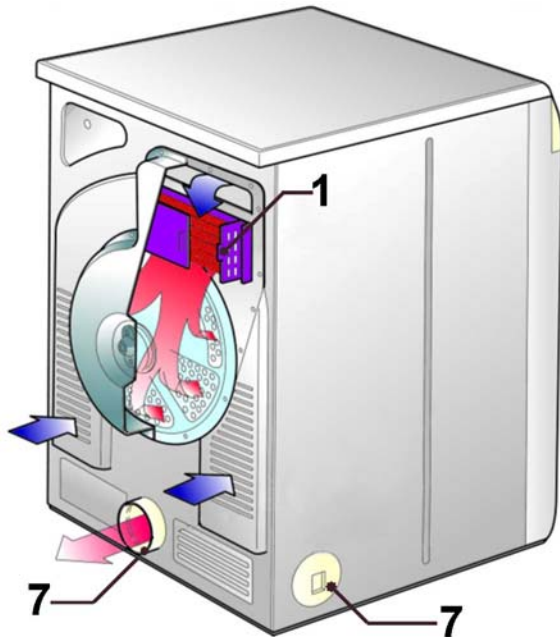

1. Heating unit
2. Drum
3. Door
4. Fluff filter
5. Fan
6. Drum rotation motor and fan
7. Vapour outlet

Hot air 

Cold air 

Fig 2



This type of appliance expels damp air into the environment.

The air from the room enters the appliance through the slots at the rear of the unit fig. 1, (blue arrows). The air enters the heating unit (1) through an opening located at the top of the back panel, it heats up (red arrows), it is carried from the back panel cover into the drum (2) fig. 2. It passes through the damp washing, reducing humidity; it leaves through the front part of the drum (here the air is hot and humid) through a fluff filter (4) located under the door surround.

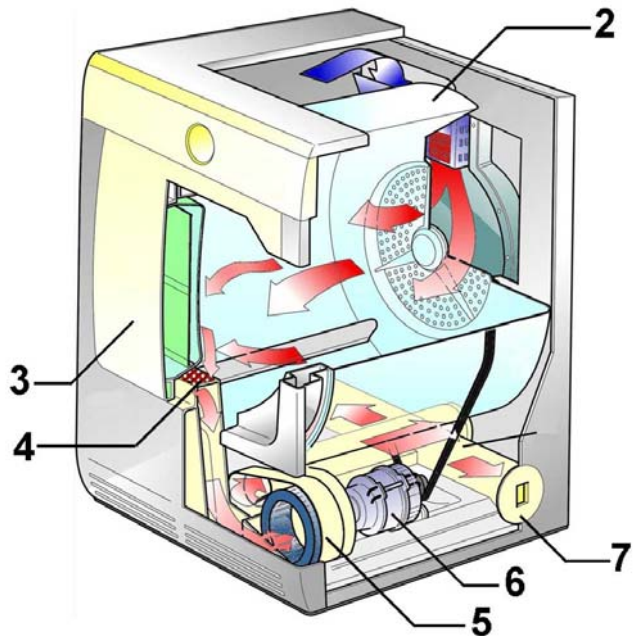
The hot, humid air passes through the conduit and enters the fan turbine (5) driven by the drum rotation motor (6), before being expelled to the outside through the relevant exhaust outlets (7), located at the sides and back.

Use a pipe with a maximum horizontal and vertical length of 2 m as a drainage extension.

6.2 Construction

1. Worktop
2. Support for controls
3. Control panel
4. Fluff filter
5. Door
6. Back panel cover
7. Back panel cover guard
8. Back panel
9. Crossbar
10. Sides
11. Conduit
12. Front
13. Base

The front and sides are made of painted sheet metal, whereas the back is in zinc-coated sheet metal. They are fastened using self-tapping screws and are connected to the base. The shaped base, in carboran, supports all the main elements.

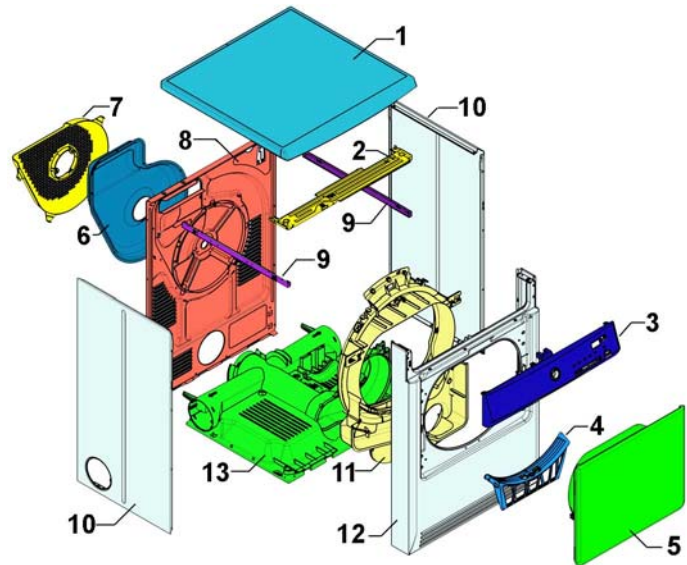

6.3 Drum

The drum is made up of two half-casings, one at the front and one at the back, joined by a plastic strip (5).

The fact that the two half-casings are separated allows the conductivity meter to measure the conductivity of the washing inside the drum.

Parts 1-2-3 are joined together by crimping.

The plastic blades are fixed to the drum casing using screws.

Drum components are made of steel plate.

The drum rear pin is fastened onto the rear flange by means of riveted eyelets.

1. Front flange
2. Drum casing
3. Rear flange
4. Blades
5. Plastic strip

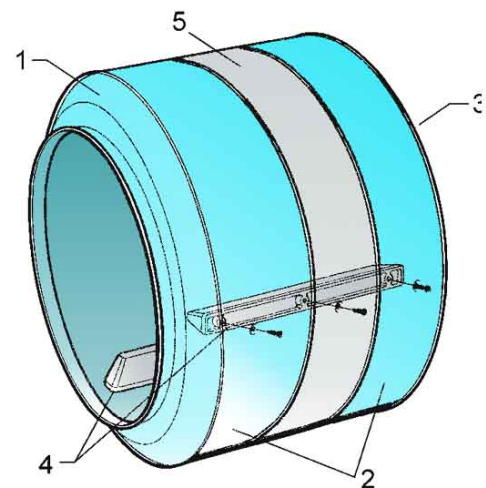

6.4 Air seals and drum pin support

Rear air seal

1. Rear gasket (fixed to the back panel)
2. Drum
3. Back panel

Rear drum support

4. Antifriction washer
5. Fixing ring (Benzing)
6. Back panel
7. Drum pin
8. Support with bushing (fixed to the back panel)

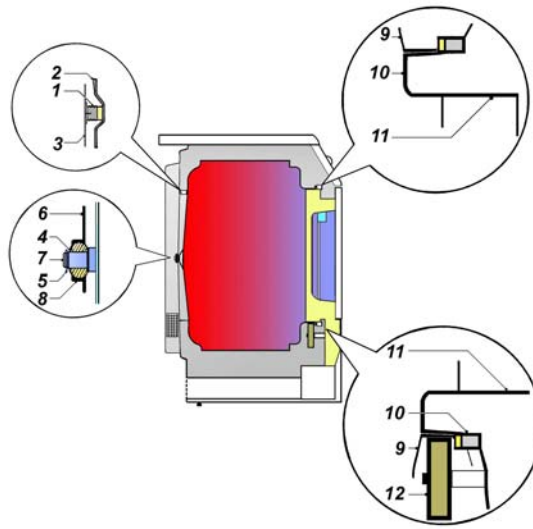

Front drum support and air seal

9. Drum
10. Felt washer with tubular support
11. Conduit

Bottom drum support

9. Drum
10. Felt washer with tubular support
11. Conduit
12. Support roller for drum movement

6.5 DRUM ROTATION MECHANISM

1. Belt
2. Motor
3. Traction spring
4. Belt tensioner

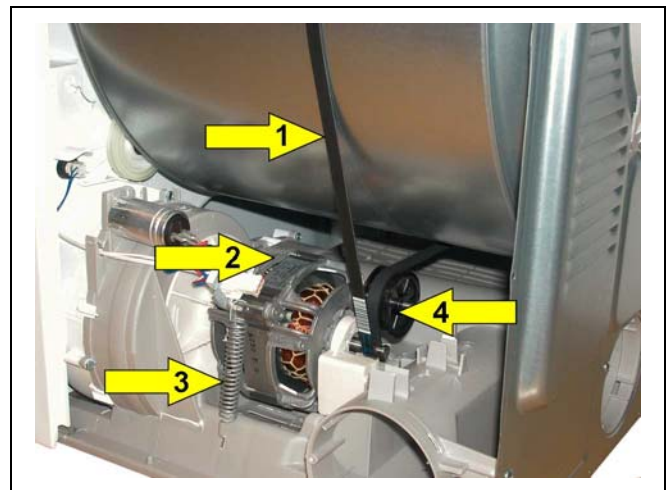

The drum is turned by means of a belt (1) which is driven by a motor pulley (2) fixed to the base and kept under tension by the spring (3).

There is a belt tensioner (4) on the motor casing, and thanks to the tension in the spring (3) this increases the angle at which the belt winds onto the drum.

Two-way rotation of the drum is determined by the circuit board, which reverses the direction of the motor, resulting in brief periods in which the drum rotates in the opposite direction, allowing the washing to unwind. During these times the heater unit is cut out due to the reduced level of ventilation inside the appliance.

7 ELECTRICAL COMPONENTS

7.1 Electronic control

1. LCD
2. Board support with board inside.
3. START/PAUSE button light diffuser.
4. Function light diffuser.
5. Button springs / support.
6. Selector pin.
7. Delay start button.
8. START/PAUSE button.
9. Function buttons.

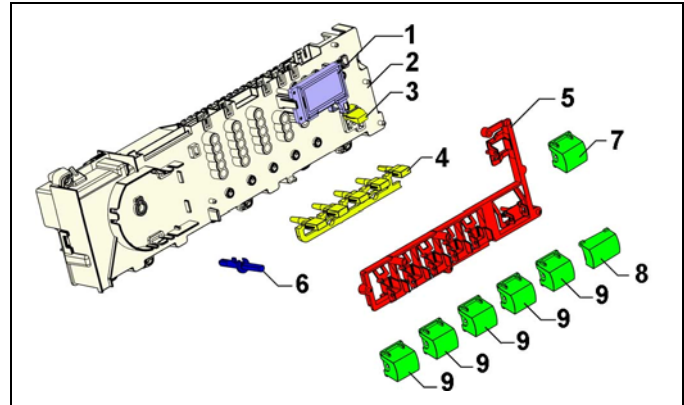

7.1.1 Main circuit board functions

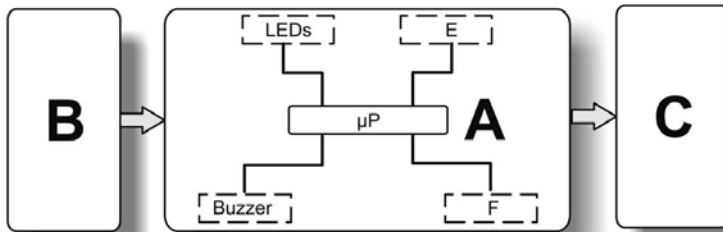

- A** Main circuit board
- B** Sensors
- C** Actuators
- e** Buttons
- f** Programme selector

- ⇒ Acquires the commands for the drying cycle set-up.
- ⇒ Powers up all the main components: motor, heating unit and drum light.
- ⇒ Controls the state of the door lock, the air temperature inside the tumble dryer (by means of an NTC probe), and the humidity level in the washing (by means of the conductivity sensor).
- ⇒ The programme selector and the buzzer are integrated into the main circuit board.
- ⇒ This board also contains the various buttons used to select the drying cycle options, the indicator LEDs for the buttons and phases/warnings.
- ⇒ Some models are equipped with an LCD display showing the remaining cycle time or any delayed start, all the drying phases, alarms and the various settings.

7.1.2 Electronic control memories: general structure

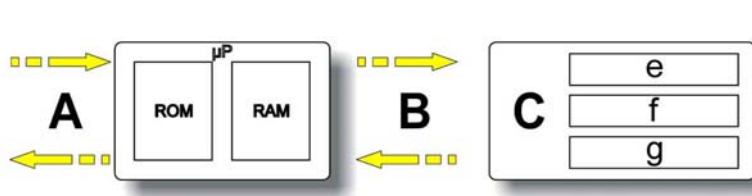

- A** Asynchronous external serial port
- B** Synchronous internal serial port
- C** EPROM external to the µP
- e** Power fail and machine status
- f** Board configuration
- g** Description of cycle

ROM

This area of the memory contains the "firmware" code comprising the appliance functions:

- ⇒ management of electrical loads (motor, heating unit);
- ⇒ management of sensors (NTC, conductivity sensor, door switch status);
- ⇒ management of the user interface;
- ⇒ management of the serial port;
- ⇒ management of power failures and alarms;
- ⇒ carrying out the drying programme.

In normal appliances this area is of the **Read Only Memory** type, and therefore cannot be modified.

RAM

This memory contains the variables, that is to say all the dynamic information used during running of the programme:

- ⇒ Machine status
- ⇒ Cycle selected
- ⇒ Alarms

The memory is deleted every time the power supply stops (in the event of a power failure or when the appliance is turned off).

The contents of the memory can be read using a computer connected via a DAAS interface.

EEPROM

This memory contains various types of data:

- ⇒ **Power fail and machine status**, that is to say the information required to start the appliance up again in the event of a power failure;
- ⇒ **Drying cycle configuration**: this file describes the various steps in the drying cycle for each family of appliances (ventilated, condensation, conductivity....);
- ⇒ **Machine configuration**: data contained in this section of the memory are those that define the configuration of each individual appliance and they are interpreted by the operating software. The following are defined in this file:
 - Programmes
 - Number and functions of buttons
 - LED functions
 - Buzzer operation
 - Working limits (voltage/frequency)
 - Machine identification (PNC + ELC + Serial number)
 - Heating unit power
 - Preferential direction of rotation of the motor

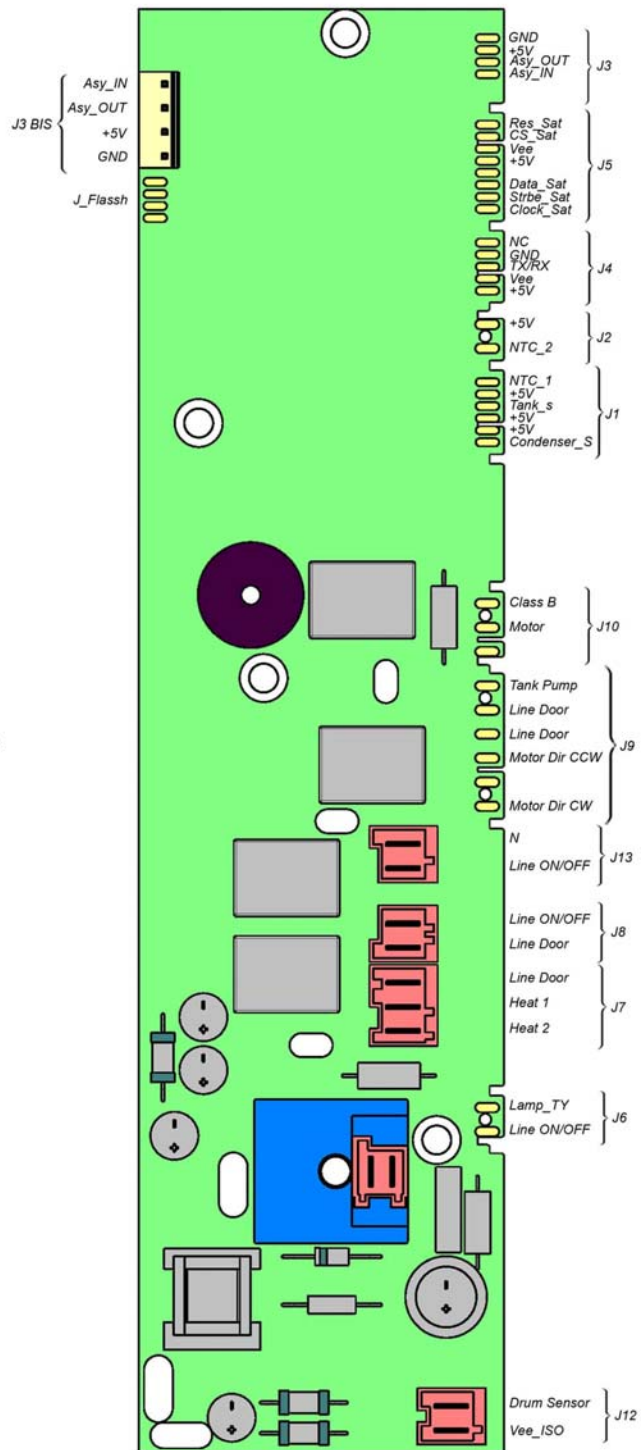
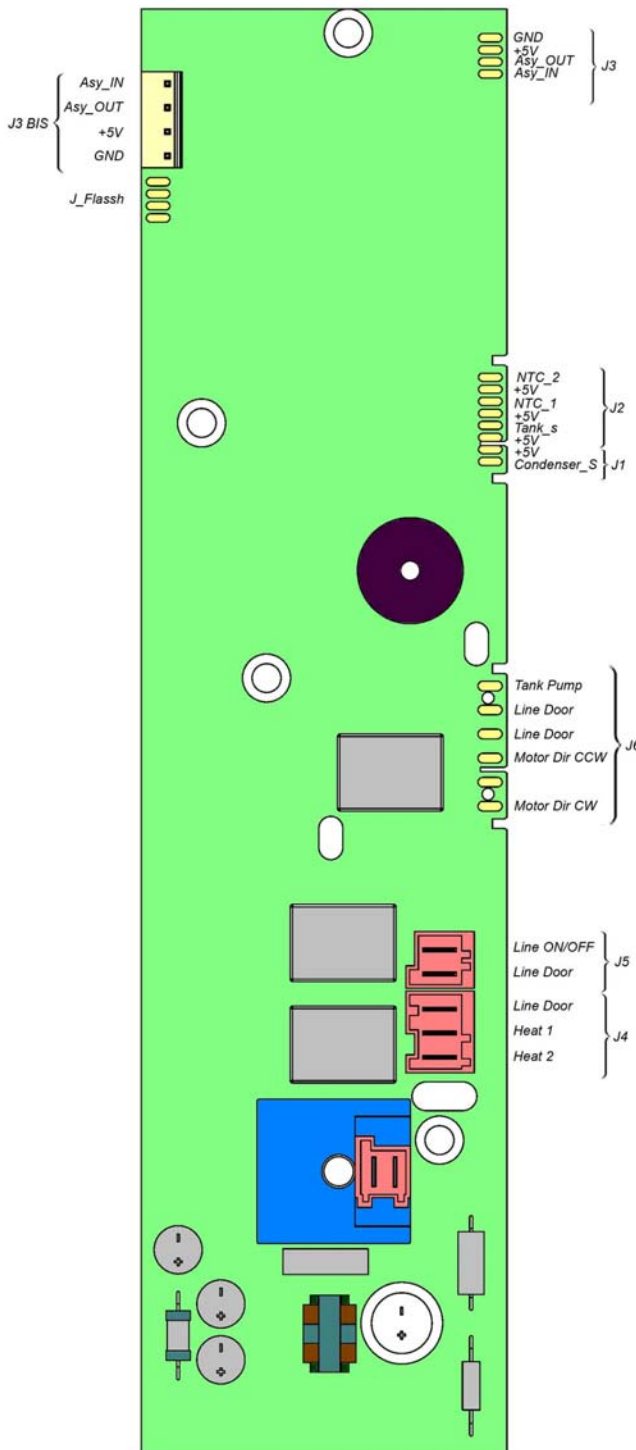

7.2 Conductivity sensor

These electronics use a conductivity sensor, comprising an electronic circuit (located inside the main circuit board) and a part outside the board comprising wiring cables, two brushes (contact sensors for the drum half-casings) and the two half-casings themselves.

The brush in contact with the front half-casing (2) is fixed in a swinging support to the conduit, and is wired to the circuit board; the other brush is in contact with the drum pin (3) inserted in the drum pin guard (4); connection of this sensor to the circuit board (1) takes place via the unit which acts as the earthing system for the appliance's electronic circuit.

As the drum is divided into two parts by an insulating strip, there is an infinite impedance between the front and rear half-casings (to which the sensors are connected) when it is empty; whereas its value is influenced by the load of washing, the type of fabric and the level of humidity in the drum.

The impedance value is approximately $1\text{M}\Omega \div 25\text{M}\Omega$. This value is transformed into an oscillation of $\sim 260\text{Hz} \div 0\text{Hz}$, which when read and processed by the electronic circuit (fuzzy logic) determines the duration and final humidity level for the chosen cycle.

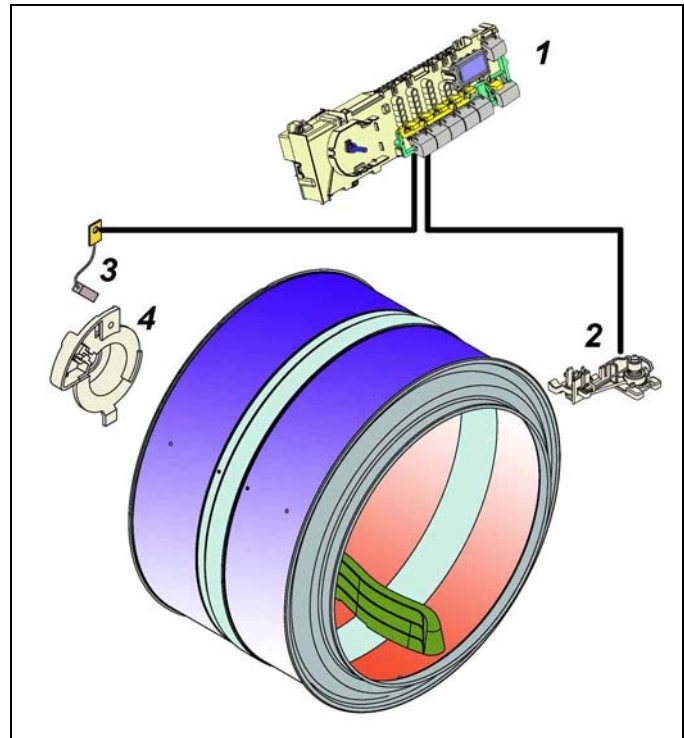

7.3 Junction box with integrated anti-disturbance filter

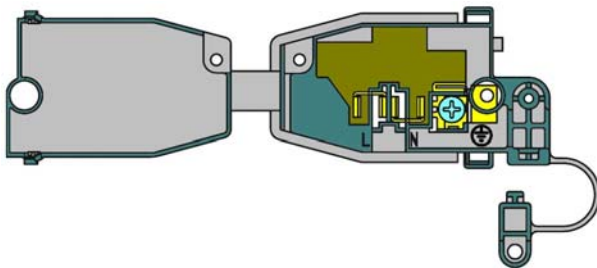

YELLOW label
 $CX = 0.25 \mu\text{F}$
 $CY = 0.27 \mu\text{F}$
 $R = 1 \text{M}\Omega$

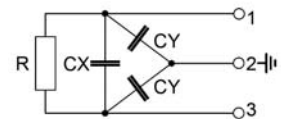

FAWN label
 $C = 0.1 \mu\text{F}$

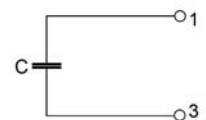

CYAN label
 $CX = 0.25 \mu\text{F}$
 $CY = 0.0047 \mu\text{F}$
 $R = 1 \text{M}\Omega$

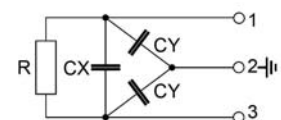

WHITE label
 $CX = 0.1 \mu\text{F}$
 $CY = 0.0025 \mu\text{F}$
 $R = 2.2 \text{M}\Omega$

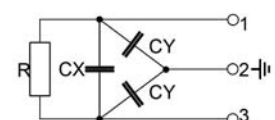

The anti-disturbance filter (inserted into the junction box) has the job of preventing any radio disturbance generated inside the tumble dryer from entering the power supply line. This device only works correctly if connected to a proper earthing system.

7.4 Heating unit

The heating unit is made up of two heating elements with different powers, inserted in ceramic supports and the whole surrounded by a sheet metal casing.

Two normally closed safety thermostats are fixed to one side of the container:

- TH1 with automatic reset (2) which triggers at a temperature of $92^{\circ}\pm 3^{\circ}\text{C}$ and cuts the power supply to the two heating elements,
- thermostat TH2 (3) triggers at 125°C and, after opening the contact, it remains in this state and cuts the power supply to the heating unit permanently.

- A. Heating element filament
 B. Safety thermostat with automatic reset TH1
 C. Safety thermostat TH2
 D. Ceramic supports
 E. Sheet metal casing

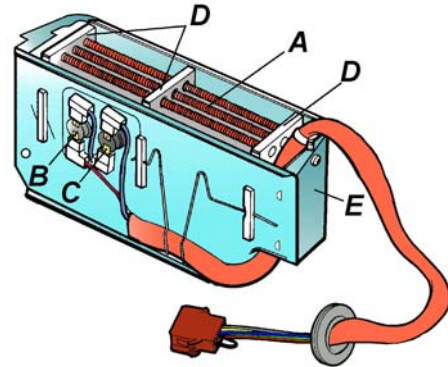
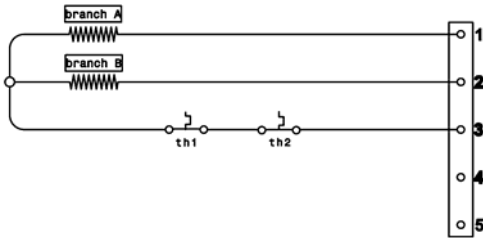

Volt (V)	Rated power (W)		Resistance 20°C (Ω)	
	Branch A (1-3)	Branch B (2-3)	Branch A (1-3)	Branch B (2-3)
230	1400	700	33,89	67,78
230	1400	800	33,89	59,75
230	1400	900	33,89	53,11
240	1400	700	36,90	73,80
240	1400	800	36,90	86,75
240	1400	900	36,97	57,83

Warning: if one of the thermostats is faulty, the entire heating unit must be replaced!

7.5 NTC probe

This sensor is fixed to the hot air fan screw. It comprises a resistor, inserted in a metal capsule, with a value that decreases as the temperature increases.

The electronic circuit reads the value of the resistor (which depends on the temperature inside the tumble dryer) and when it drops below a certain value, cuts the power supply to the heating unit. As the air cools, the value of the resistor increases, and when it reaches a certain value the electronic circuit restores the power supply to the heating unit. This occurs every time the temperature inside the appliance exceeds a given value, which varies according to the drying cycle that has been selected.

1. Metal capsule
2. NTC
3. Terminals

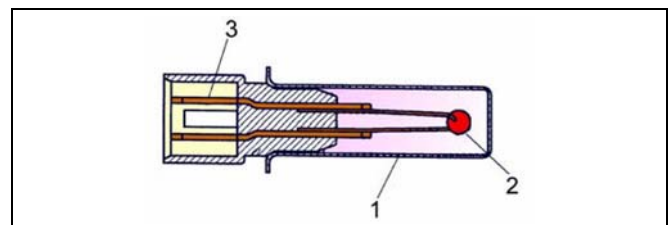

TEMPERATURE (°C)	RESISTANCE (Ω)		
	Rated value	Maximum value	Minimum value
20	6050	6335	5765
60	1250	1278	1222
80	640	620	660

7.6 MOTOR UNIT

1. Fan
2. Motor
3. Belt tensioner

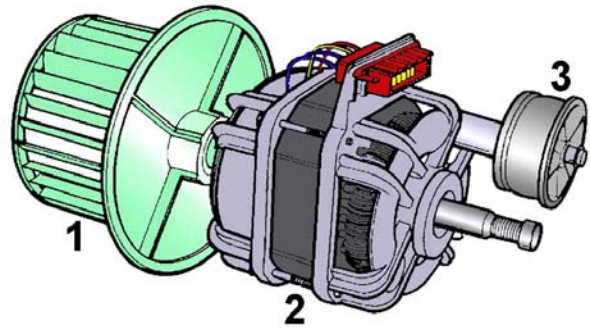
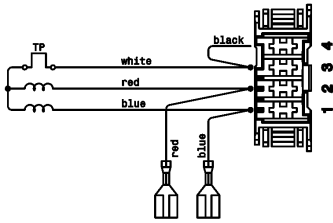

It is possible to get an idea of the efficiency of the motor by measuring the resistance of the coils:

	PIN 1-3	PIN 2-3
Resistance	22 Ω / 26.2 Ω ± 7%	20.8 Ω / 26.2 Ω ± 7%

General characteristics:

The motor unit is made up of a belt tensioner (3), a fan (1 which sucks the air from the inside of the appliance and forces it towards the outlets) and the single-phase induction motor with thermal cutout.

Single-phase induction motors are characterised by a lack of torque on initial start-up, and this is obtained by adding a coil crossed by a current that is 90° out of phase with respect to the main one. This phase offset is obtained by means of a capacitor serial connected to the coil.

The motor used in tumble dryers has the stator made up of two identical coils, the 90° current offset is determined by the condenser (C) which is connected in series first to one coil and then to the other (to determine rotation in one direction or in the opposite direction). This change in connections is determined by the circuit board.

7.7 Door lock with door microswitch incorporated

The door lock is an electromechanical device that powers electrical loads after the door has been closed and the programme selector has been turned (ON/OFF closed). It is fitted with a child safety device which, in case of need, allows the door to be opened by pushing from the inside.

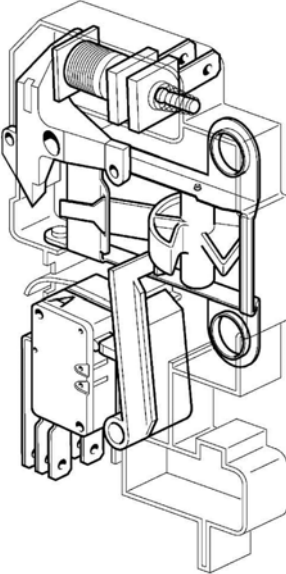
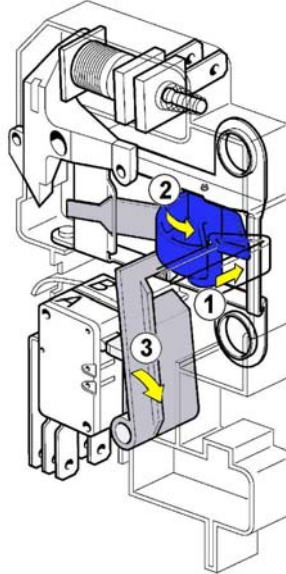
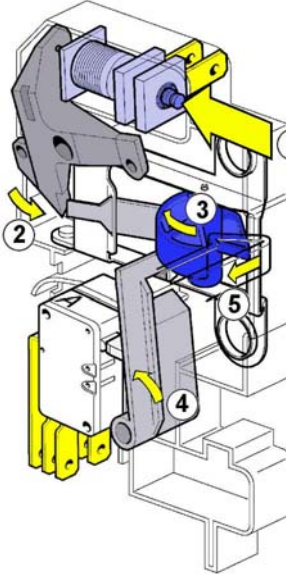
		
<p>Door open: the lever presses the button on the switching device "A"; in this position contacts 1-2 are closed. In certain models, these feed the drum lamp when the main switch is closed.</p>	<p>When the door is closed: the latch (1) turns the cam (2): this movement releases the lever (3) and the deviator button "A" changes position, closing contacts 1-3 and thus powering up all components in the appliance (cutting the power supply to the drum lamp, if there is one).</p>	<p>When the open door button is pressed: the main circuit board powers the coil; the core (1), as it moves, acts on the anchor (2), unlocking the cam (3). The latter rotates and moves the lever (4) which closes the deviator contacts "A" in position 1-2, and releases the door latch (5).</p>

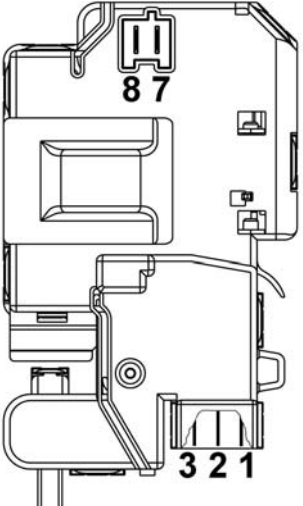
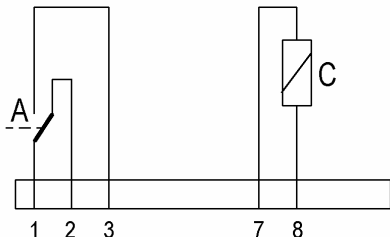
Position of connectors	Wiring diagram
	 <p>A Deviator in door open position</p> <ul style="list-style-type: none"> ▪ Contacts 1-2: 0 Ω ▪ Contacts 1-3: ∞ Ω <p>C Door opening coil</p> <ul style="list-style-type: none"> ▪ Contacts 7-8: ~ 90Ω

7.8 Door lock without door microswitch incorporated

Dependent on the version, the door lock may be mechanical with manual door opening or electronic with the door opening when a button is pressed. In the second case the door is opened by an electromagnetic coil which releases the fastening latch by means of a lever.

The door lock is fitted with a child safety device which, in case of need, allows the door to be opened by pushing from the inside.

1. Latch lever
2. Coil (present on models with automatic opening)
3. Coil guard

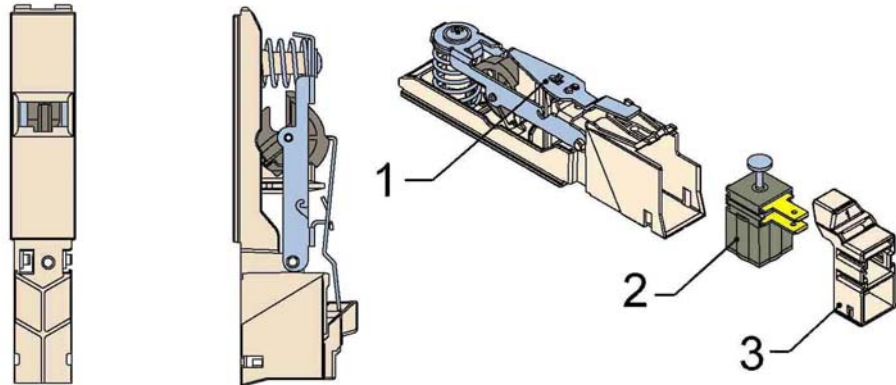

7.9 Door microswitch

The door switch powers the electrical components after the door has been closed and after the selector has been turned (ON/OFF closed). The switch is located above the door opening and it is closed, when the door itself is closed, by means of a pin located on the door itself.

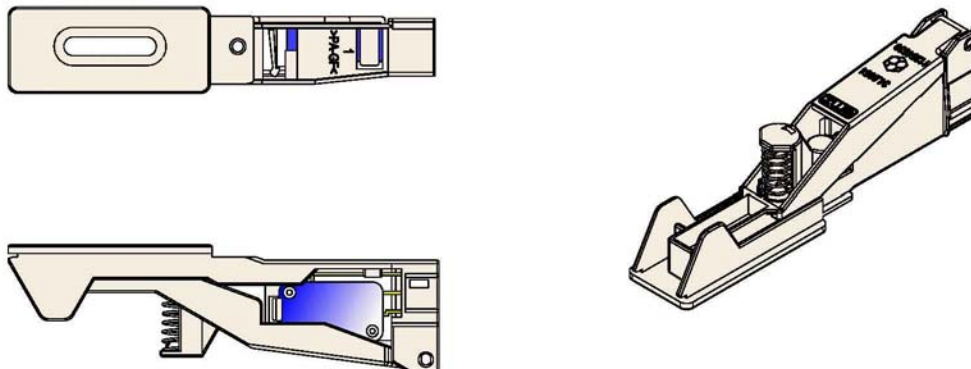

8 WIRING DIAGRAMS

8.1 Wiring diagram for tumble dryers with conductivity sensor

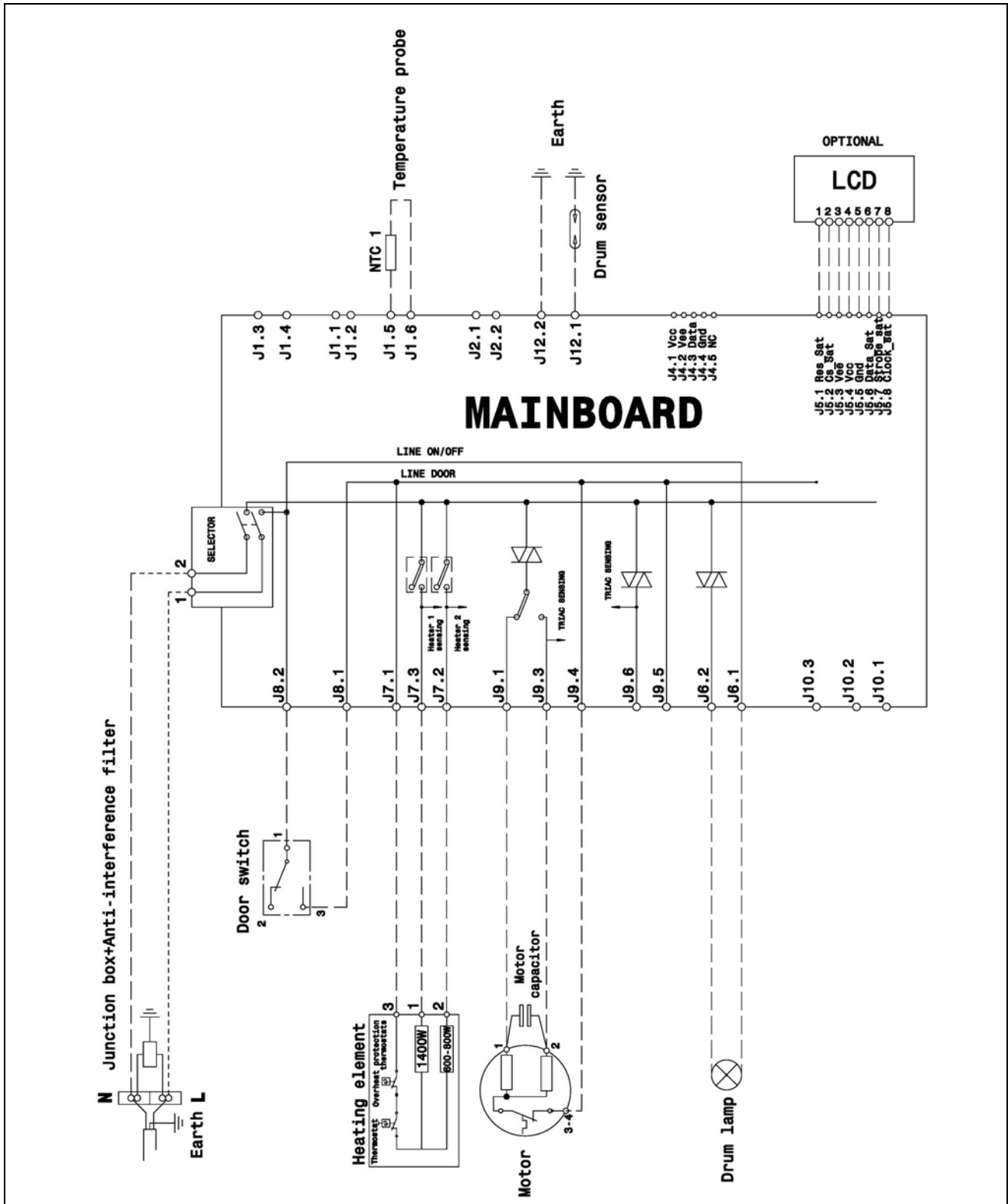

8.2 Wiring diagram for tumble dryers with temperature probe.

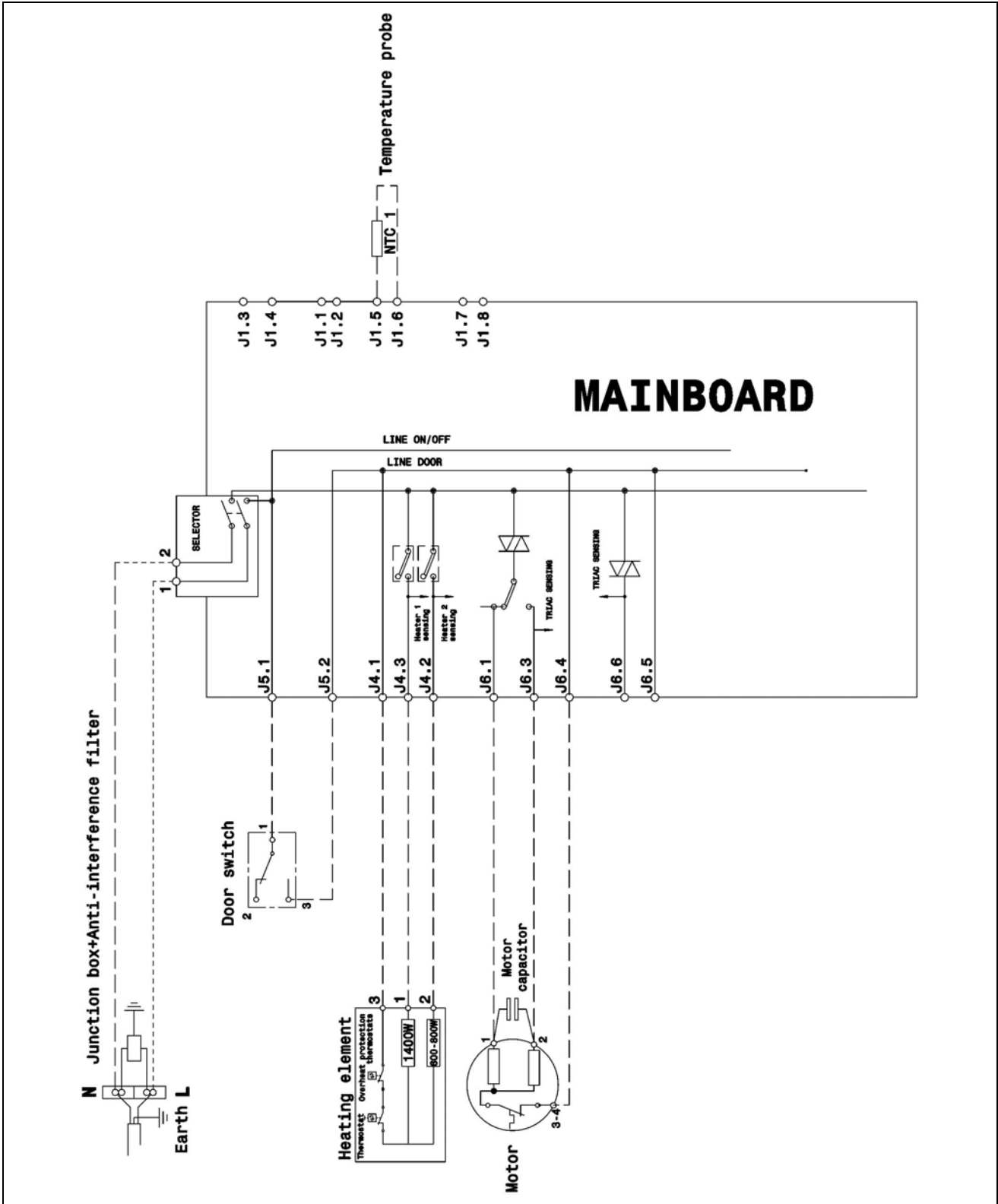

9 DIAGNOSTIC SYSTEM

This mode allows to check appliance operations and to read alarms.

9.1 Accessing diagnostics

1. The appliance must be turned off.
2. Turn the appliance on, turning the programme selector by one position in a clockwise direction.
3. Wait until the LEDs light up and the buzzer sounds, then press the START/PAUSE button and the first button to the left of it simultaneously.

Warning: this operation must be carried out within 5 seconds!

4. Keep pressing the buttons until the LEDs start to flash and the buzzer sounds.

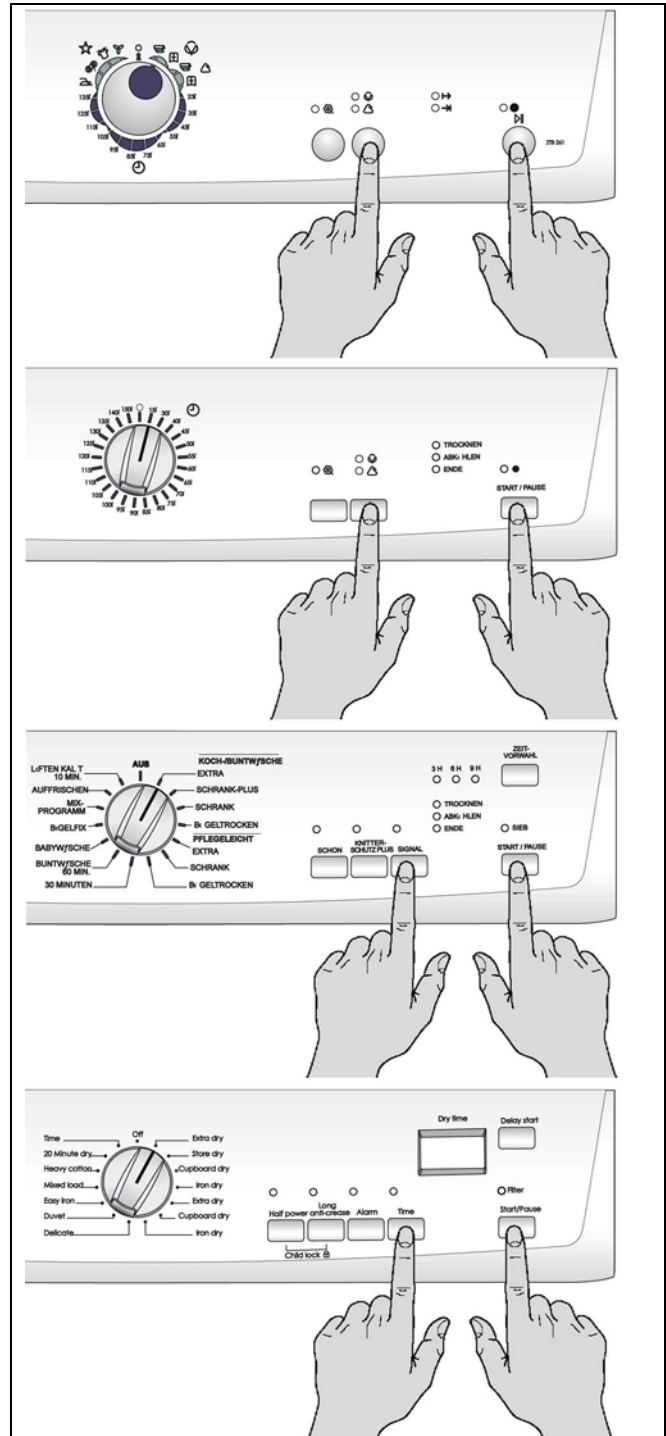

9.2 Quitting the diagnostics system

To quit the diagnostics system, turn the programme selector to position **zero**, turn the appliance on so as to reset all the functions, then turn the appliance off again.

9.3 Diagnostic test phases

After activating the diagnostic system:

- ⇒ in the first position it performs a function test of buttons and relevant LEDs.
- ⇒ When the programme selector is turned in a **clockwise direction**, operation of the various components is diagnosed and the alarms are read.

WARNING!

- The alarms are active during diagnostic testing of components. If an alarm appears, move the selector to the first position to exit the alarm status and optionally continue the test (if the alarm is not triggered again).
- In order to test the conductivity sensor properly in case of a short-circuit (position 8), the cover must be removed and a short circuit must be created between the two half-casings of the drum or between the front casing and earth. The time available to create this short-circuit, once this phase starts, is just one second; this means you must **prepare the short-circuit before you move the selector to position eight** (it is advisable to do this at a position in which the drum is stopped and then to move quickly to that position). **If the short-circuit is not created properly, the circuit board will display alarm E32** (sensor frequency too low). To exit this alarm, move the selector to the first position.
- Open the capacitor hatch to check that the switch is working properly: the buzzer will sound a sequence of 4 "beeps" of different intensities, repeated once every 7 seconds.

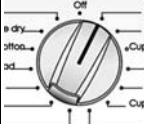
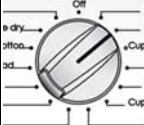
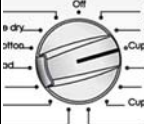
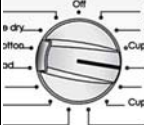
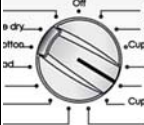
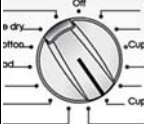
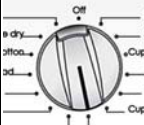
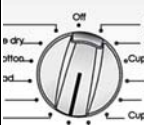
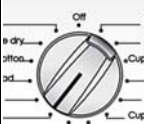
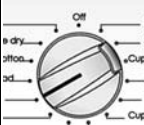
Selector position	Components activated	Working conditions	Function tested
1 	<ul style="list-style-type: none"> ➤ All LEDs and Digits will turn on in sequence. ➤ When you press a button, the corresponding LED lights up and the Buzzer sounds. 	Always active	User interface functions
2 	POSITION NOT USED	/	/
3 	<ul style="list-style-type: none"> ➤ Motor TRIAC and relay. 	Door closed Max. time 10 min.	Drum anticlockwise rotation test
4 	<ul style="list-style-type: none"> ➤ Motor TRIAC powered step-by-step. 	Door closed Max. time 10 min.	Tests clockwise rotation of the drum (low speed for visual control of drum half-casing assembly).
5 	<ul style="list-style-type: none"> ➤ One branch of heating element only. ➤ Motor TRIAC for fan. 	Door closed Max. time 10 min.	Heating unit (half power)
6 	<ul style="list-style-type: none"> ➤ Both heating elements in the heater unit. ➤ Motor TRIAC for fan. 	Door closed Max. time 10 min.	Heating unit (full power)
7 	<ul style="list-style-type: none"> ➤ Conductivity sensor with drum in short circuit. The test lasts 4 sec. 1 sec. to make the short circuit, during which time the phase/warning LEDs flash: if at the end the result is OK the LEDs will go out, if something is wrong they will flash and the alarm E32 will be displayed. 	Door closed Short-circuit between the two drum casings	Checks the conductivity sensor during a short circuit.
8 	<ul style="list-style-type: none"> ➤ Conductivity sensor. The test lasts 4 sec., during which time the phase/warning LEDs flash: if at the end the result is OK the LEDs will go out, if something is wrong they will flash continuously. 	Door closed	Checks the conductivity sensor with the circuit open.
9 	POSITION NOT USED	/	/
10 	<ul style="list-style-type: none"> ➤ Read/delete the last alarm. 	---	---

10 ALARMS

10.1 Displaying user alarms

Alarm management can be configured so that they can be partially or totally visible to the user, depending on the model.

Normally, all alarms except E61, E97 and EH2 are visible to the user.

When an alarm occurs, the drying cycle may be stopped or paused; in certain cases a forced cooling cycle is started, for safety. In this case the circuit board, if possible, disconnects the relay feeding the heating unit and powers the motor to provide the ventilation necessary to cool down the drum. The cycle remains in operation until the user turns the appliance off.

10.2 Viewing alarms during normal operation

In models with LCD the family of the current alarm is displayed for the user.

Let us take alarm E53 (problem with the motor TRIAC) as an example; the following will be displayed:

- first digit: letter "E" (error)
- second and third digit: the number "50", i.e. the family of the alarm E53)

In all models the same number will be displayed using a repeated sequence of flashes from the RED START LED with a specific cycle (0.4 seconds on, 0.4 seconds off with a pause of 2.5 seconds between sequences).

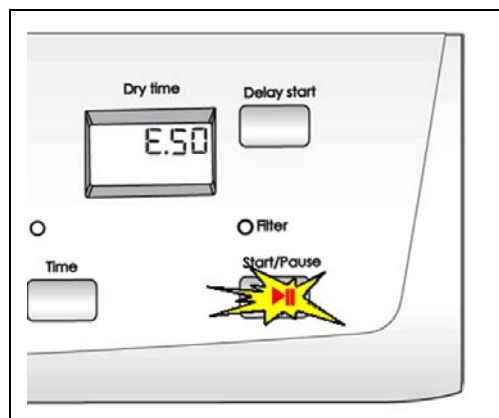

In the case of E53, the series of five flashes indicates the first of the two figures in alarm E53 (the alarms that relate to the same function are grouped together in families).

10.3 Reading the alarms

To read the last alarm stored in the circuit board EEPROM:

- start diagnosis mode (see paragraph);
- turn the programme selector in a clockwise direction to position ten, taking care not to stop at the other positions, as this might trigger Error 32).

10.4 Displaying the alarm on all models

The alarm is displayed by a repeated sequence of flashes from the START LED (0.4 seconds on, 0.4 seconds off, with a pause of 2.5 seconds between sequences). The buzzer will also sound in synchrony with flashing of the LEDs.

RED START LED: this indicates the first figure in the alarm code (family).

GREEN START LED: this indicates the second figure in the alarm code (number within the family).

10.4.1 Viewing any other alarms

Press the START button to view all alarms present in the machine in succession.

Configuration errors E93 are displayed by flashing of all the LEDs, and it is not possible to access the diagnostics system.

10.5 Deleting the last alarm

It is good practice to delete the alarm recorded:

- after you have read it, to check whether or not it occurs again during diagnostic tests;
 - after repairing the appliance, to check whether or not it occurs again during testing.
1. Start diagnostics mode.
 2. Turn the programme selector in a clockwise direction to position ten.
 3. Press the Start/Pause button and the button immediately to the left of it simultaneously.
 4. Hold the buttons for approximately 5 seconds.
 5. After deleting, E00 will be displayed.

10.6 Notes on the behaviour of certain alarms

- **Configuration alarm E93:** when these alarms are detected (on start-up) the machine will stop and all the LEDs will light up: it will not be possible to access diagnostics mode and the only available option is to turn the appliance off (selector set to position "0").
- **Alarms EH1-EH2-EH3:** in the event of problems with the supply voltage, the machine will remain in a state of alarm until the mains frequency or voltage returns to normal values or until the appliance is turned off (programme selector set to "0"). The alarm family "H" is displayed and the diagnostics mode cannot be accessed and the "quick alarm viewing" mode cannot be used: the alarm can only be read in full when the situation has normalised.

11 Alarm Summary Table

Alarm	Description	Possible fault	Machine status/action	Reset command
E00	No alarm.	---	---	---
E31	Conductivity sensor signal frequency too high.	Main circuit board faulty	Alarm only active in diagnosis mode.	---
E32	Conductivity sensor signal frequency too low.	Faulty wiring. Brushes worn/faulty. Main circuit board faulty.	Cycle blocked	OFF
E45	Door closed sensor.	Door lock faulty. Faulty wiring. Main circuit board faulty	Cycle blocked	OFF
E51	Motor power supply TRIAC short-circuiting.	Motor faulty. Faulty wiring. Main circuit board faulty.	Cycle blocked	OFF
E52	Motor thermal cutout triggered.	Motor faulty. Motor thermal cutout has triggered. Faulty wiring. Main circuit board faulty	Cuts the power supply to the heating unit and to the motor. If the problem ceases, the alarm will be stored and the cycle will continue. If the fault persists after attempting to repower the appliance a few times (approximately 35 min.), alarm E51 is triggered.	OFF
E53	Motor TRIAC "sensing" circuit faulty.	Main circuit board faulty.	Cycle blocked	OFF
E54	Motor blocked.	Washing load is too large. Power supply voltage low. Motor/drive system blocked.	Cycle in pause after several attempts to re-power the motor.	Start

E62	Heating unit power relay faulty.	Heating unit faulty. Faulty wiring. Main circuit board faulty.	Forced cooling cycle	OFF
E63	Heating unit automatic reset thermostat triggered.	Thermostat faulty (replace heating unit). Heating unit faulty. Faulty wiring. Main circuit board faulty.	Turn the power supply to the heating unit off. If the problem ceases, the alarm will be stored and the cycle will continue. If the fault persists after attempting to repower the appliance a few times, the alarm E62 is triggered.	OFF
E64	Heating element thermostat.	Heating element thermostat faulty. Faulty wiring. Main circuit board faulty.		
E71	NTC1 probe malfunction.	NTC1 probe faulty. Faulty wiring. Main circuit board faulty.	Forced cooling cycle	OFF
E82	Selector malfunction in OFF position.	Circuit board wiring. Board faulty		
E83	Incorrect selector positions.	Circuit board wiring. Board faulty.		
E93	Appliance configuration error.	Bad EEPROM configuration. Main circuit board faulty.	Cycle blocked	OFF
E94	Drying cycle configuration error.	Bad EEPROM configuration. Main circuit board faulty.	Cycle blocked	OFF
E97	Inconsistency between selector and cycles.	Configuration error.	Cycle blocked	OFF
EH1	Appliance power supply frequency outside limits.	Problem with the power supply network (incorrect/disturbed). Main circuit board faulty.	Cycle blocked. If the power supply becomes stable again before the time-out, the cycle will restart.	OFF
EH2	Power supply voltage too high.	Problem with the power supply network (incorrect/disturbed). Main circuit board faulty.	Cycle blocked	OFF
EH3	Power supply voltage too low.	Problem with the power supply network (incorrect/disturbed). Main circuit board faulty.	Cycle blocked. If the power supply becomes stable again before the time-out, the cycle will restart.	OFF

12 CANNOT ACCESS THE DIAGNOSTICS PROGRAMME

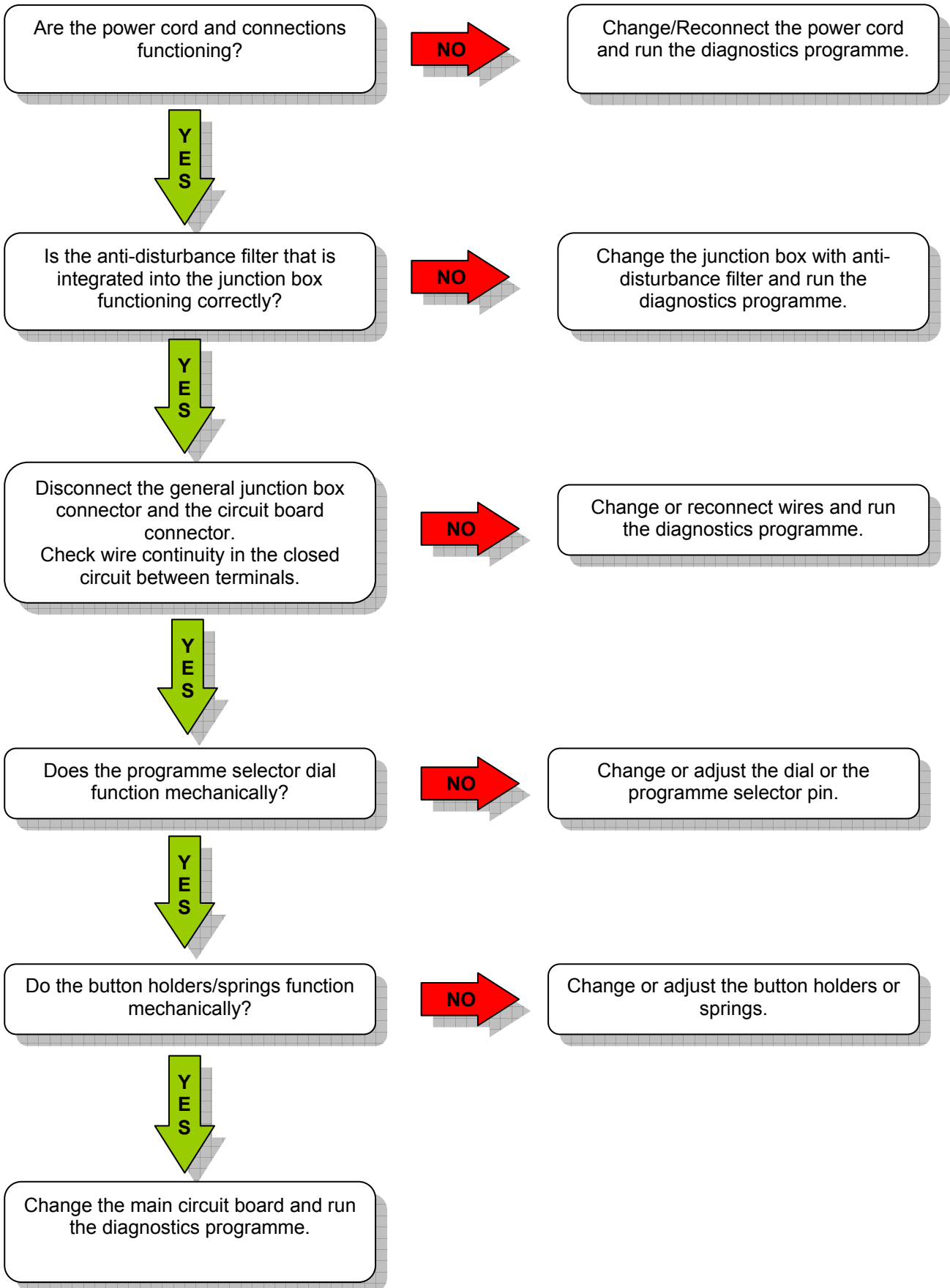

13 ACCESS TO COMPONENTS



Individual components must only be accessed after the power cable has been disconnected from the socket.



13.1 Door

Unfasten the 2 screws fixing the door to the front.



13.2 Door fastening latch

There are two types of latches, depending on the type of door lock fitted on the machine:

- latch for AEG door lock,
- latch for EMZ door lock with fitted microswitch.

In both models the reassembly procedure is as follows:

1. unfasten the screw fixing the door lock;
2. use a screwdriver to lift up the fastening hook, being careful not to damage it;
3. turn the whole block upwards and remove it.



When reassembling the door fastening latch make sure that the spring is correctly positioned.



13.3 Door lock

13.3.1 AEG model door lock

1. Unfasten the screw that fixes it in place.
2. Lower it slightly and extract it, turning it forwards.

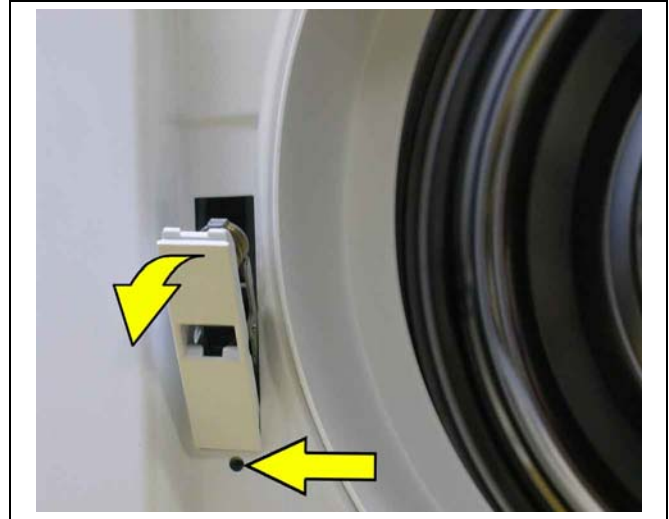

13.3.2 EMZ model door lock with fitted microswitch

1. Remove the left hand side panel (see paragraph).
2. Unfasten the 2 screws fixing the door lock to the front.
3. Remove the door lock, turning it slightly and moving it upwards.

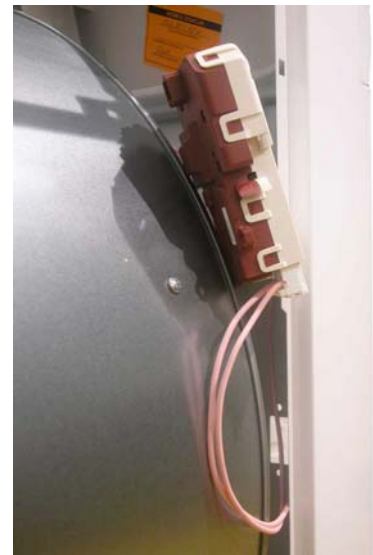
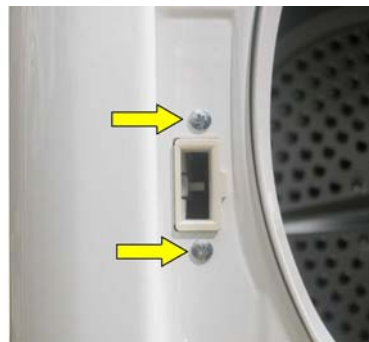

13.4 Door microswitch latch (certain models only)

With a screwdriver, press on the locking hook and turn it in the direction indicated by the arrow.



13.5 Door microswitch (certain models only)

1. Unfasten the fixing screw.
2. Extract it slightly and move it to the left until it reaches the connector.
3. Disconnect the connector and fasten it to the front with a piece of sticking tape to prevent it from going back into the machine.

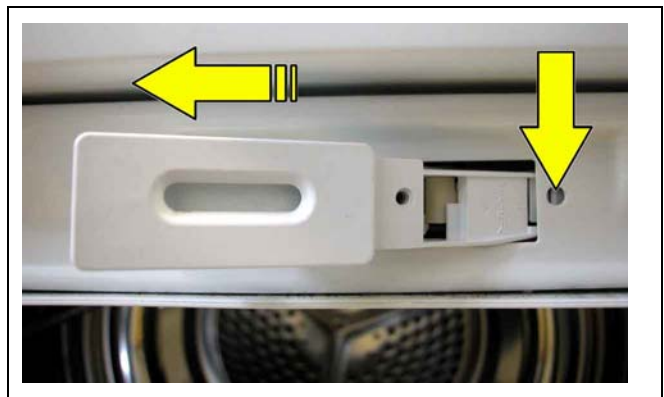

13.6 Fluff filter

1. Open the door.
2. Remove the filter upwards.
3. Press the clip that holds it shut, open it and clean it after each cycle. If obvious traces of dust or fluff remain, wash it under running water.

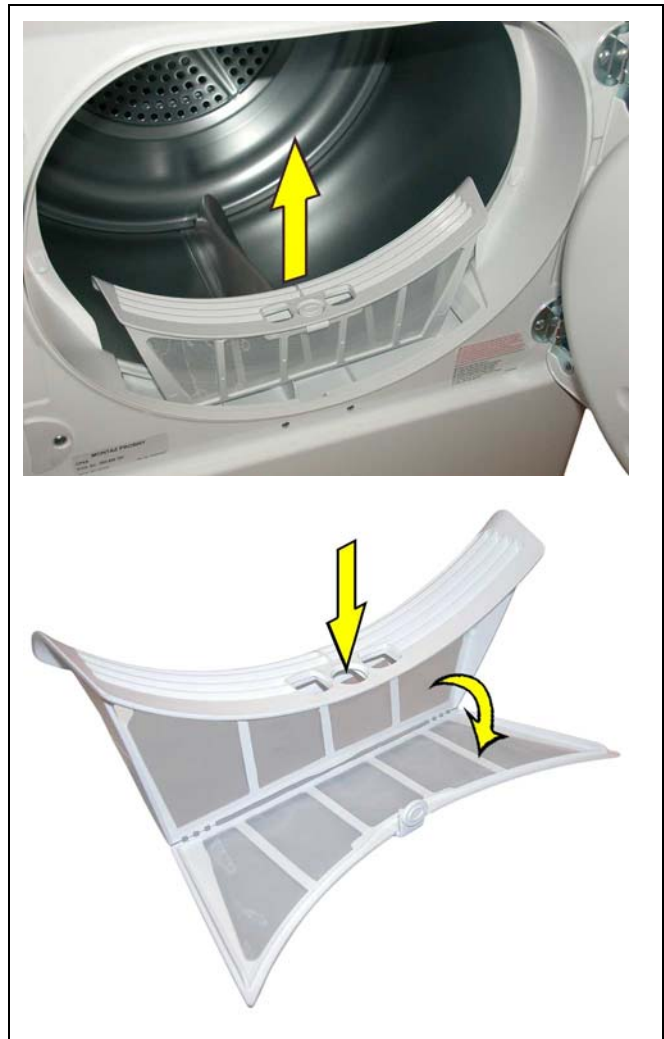

13.7 Drum lamp

The drum lamp can be replaced from inside the drum.

1. Unscrew the lamp casing and replace the lamp with one of the same type.

When replacing the lamp casing, make sure that the gasket is properly positioned in the housing.



13.8 Worktop

1. Unfasten the two screws fixing the worktop.
2. Pull it in the direction indicated by the arrow and lift it up.

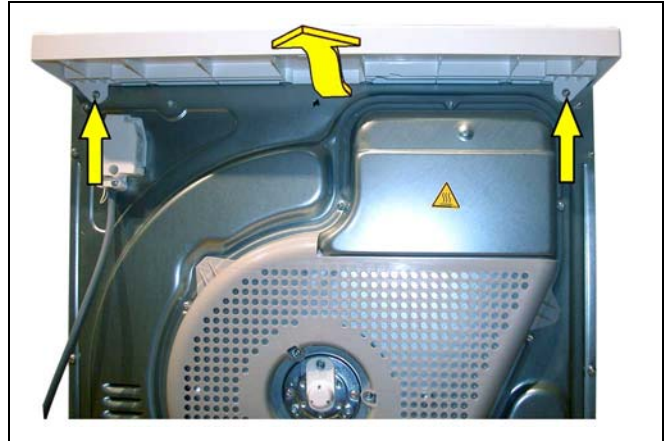

13.9 Control panel

1. Unfasten the 4 screws fixing the control panel and crossbar to the frame.
2. Lift the whole unit slightly and turn it forwards.
3. Unfasten the screw fixing the crossbar to the control panel, and remove the crossbar.
4. Disconnect all the wires, taking care to note down their positions for when you reconnect them.



13.10 Main circuit board

13.10.1 Removing the board

1. Unfasten the 5 screws fixing the board assembly to the control panel.
2. Use a screwdriver to lever off the fixing clips without straining them too much, and remove the entire board assembly.

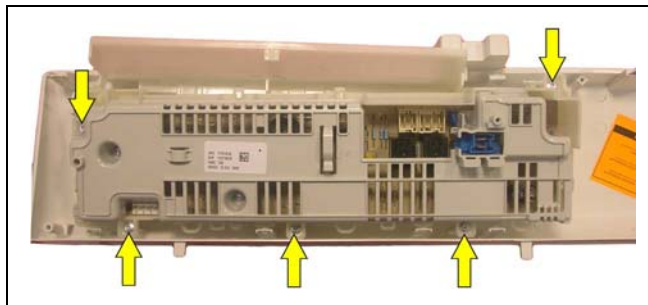

13.10.2 Removing the selector pin

The selector pin can be removed after removing the main circuit board.

1. Turn the selector pin to the OFF position.
2. Pull it outwards.

WARNING

If the pin does not come out, check carefully to ensure that it is in the proper OFF position.

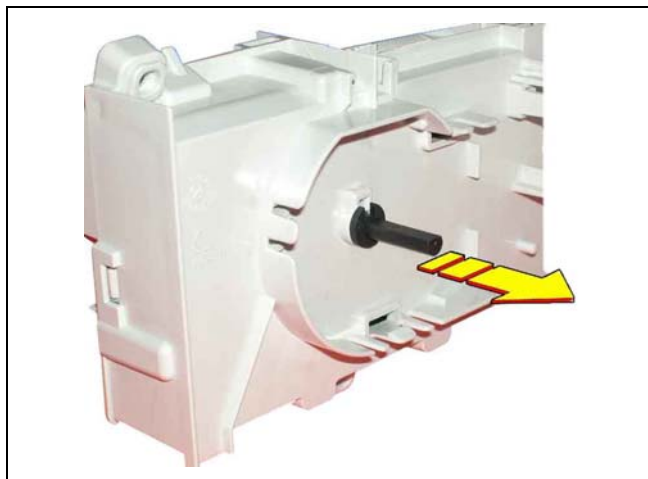

13.10.3 Removing the selector dial

The selector dial can be removed after removing the main circuit board.

1. Press the two fixing clips towards the centre.
2. Push the dial outwards.

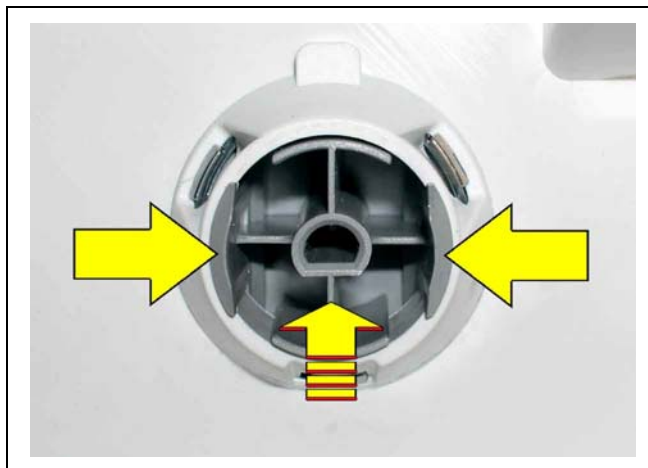

13.10.4 Buttons and button springs

Buttons, together with button springs and light diffuser remain attached to the main circuit board support by means of side clips.

To remove them, lever them off gently with a screwdriver without forcing them.

If the individual buttons are removed, before replacing them check the number on the inside of each one and make sure they are positioned as shown in the figure.

13.11 Back panel cover

1. Remove the worktop (see paragraph).
2. Unfasten the three screws (1) fixing the back panel guard (made of plastic) at the centre.
3. Use a screwdriver to release the hooks that fasten it on the outside. (2)



4. Unfasten all perimeter screws fixing the back panel cover.



The figures show a conductivity sensor tumble dryer with rear brush; in machines that are not fitted with a rear brush the procedure is exactly the same.

13.12 Heating unit

1. Remove the worktop (see paragraph).
2. Remove the plastic back panel guard and the back panel (see paragraph).
3. Disconnect wires from cable clamps.
4. Disconnect the connector.
5. Unfasten the screw fixing the heating unit to the back panel, and remove it.



13.13 Anti-disturbance filter

1. Remove the worktop (see paragraph).
2. Disconnect the anti-disturbance filter.
3. Remove the 2 fixing screws.

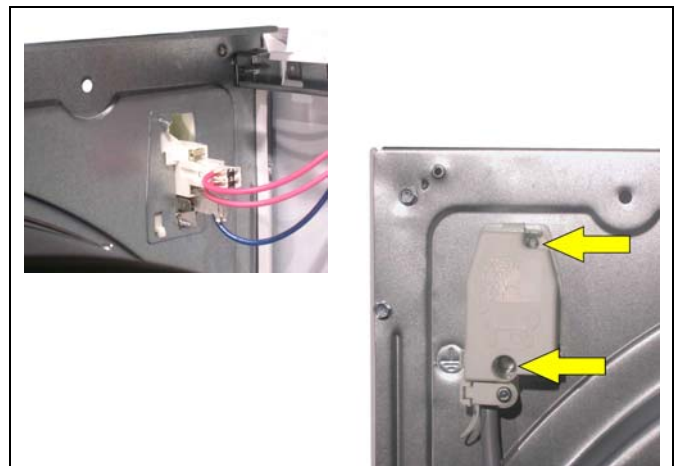

13.14 Sides

1. Remove the worktop (see paragraph).
2. Use a screwdriver to remove the fastening clips.
3. Remove the internal screws.
4. Remove the air outlet plugs and unfasten the fixing screw.
5. Unfasten the rear fixing screws.
6. After removing all the screws, lift the panels slightly upwards and remove them.

When reassembling, make sure that the holes drilled in the base of the panels coincide with the positioning points in the base.

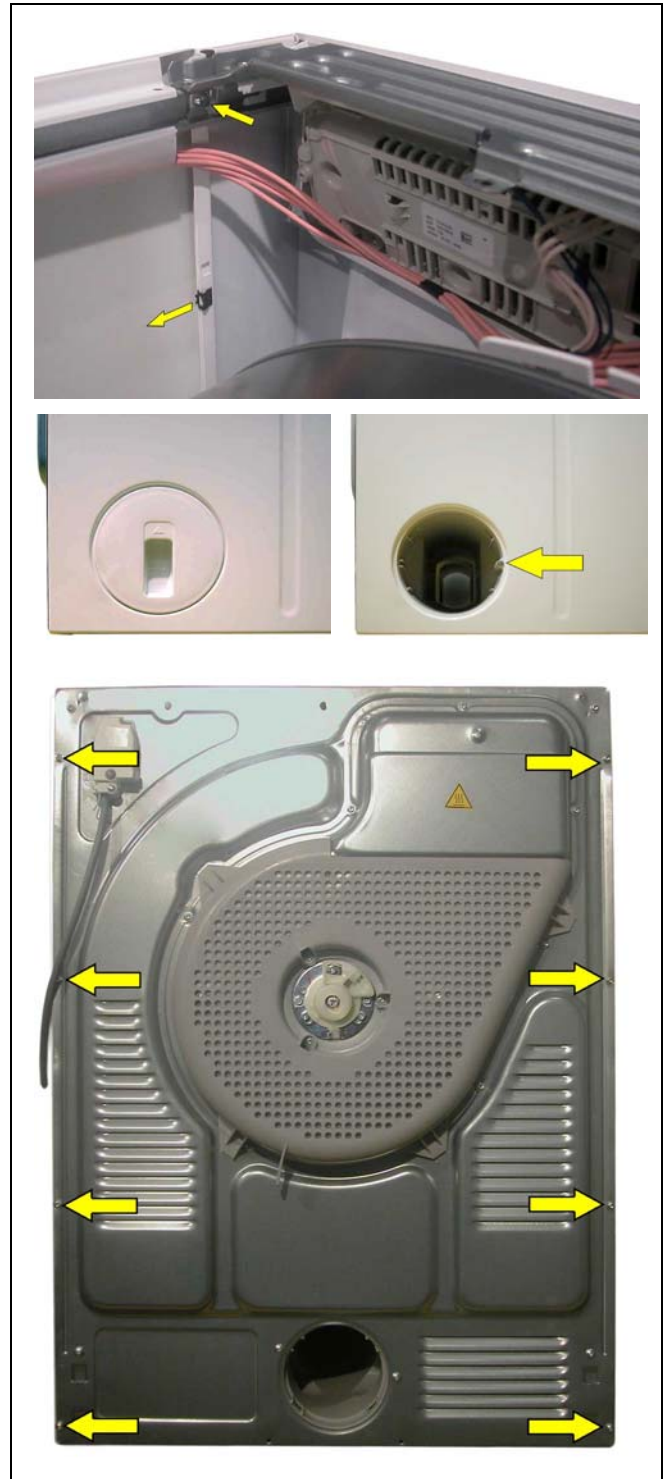

The figures show a conductivity sensor tumble dryer with rear brush; in machines that are not fitted with a rear brush the procedure is exactly the same.

13.15 NTC probe

1. Remove the probe towards the inside of the machine.
2. Move the connector fastening clip slightly, and remove the connector.

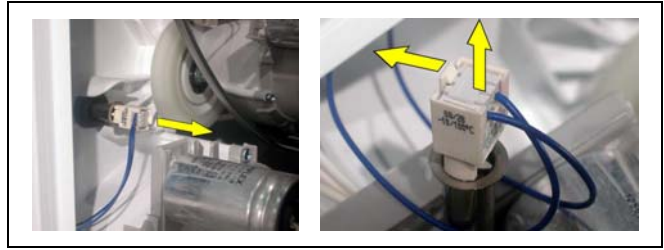

13.16 Running capacitor

1. Disconnect the connectors.
2. Move the fastening hook and remove it by pulling upwards.

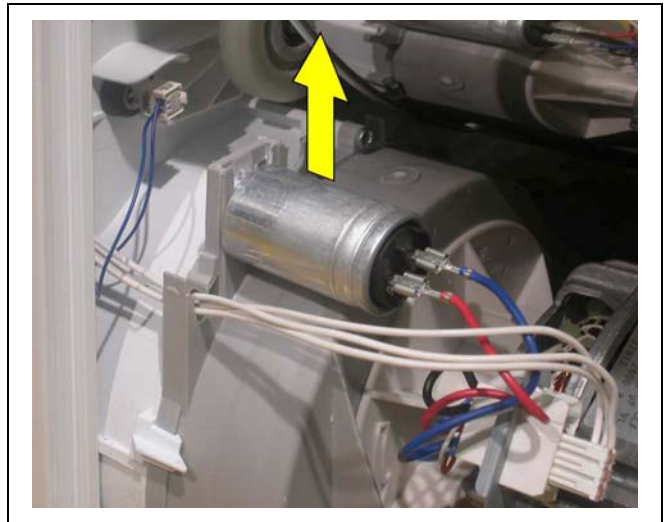

13.17 Motor/fan assembly

1. Remove the worktop (see paragraph).
2. Remove the right hand side panel (see paragraph).
3. Unhook the suspension spring.
4. Remove the belt from the pulley.
5. Disconnect the wiring connector from the junction box and from the capacitor.
6. Disconnect the teeth fastening the motor supports to the base.
7. Turn them towards the inside of the machine until they are completely out of the guides.
8. Lift up the motor and remove it.

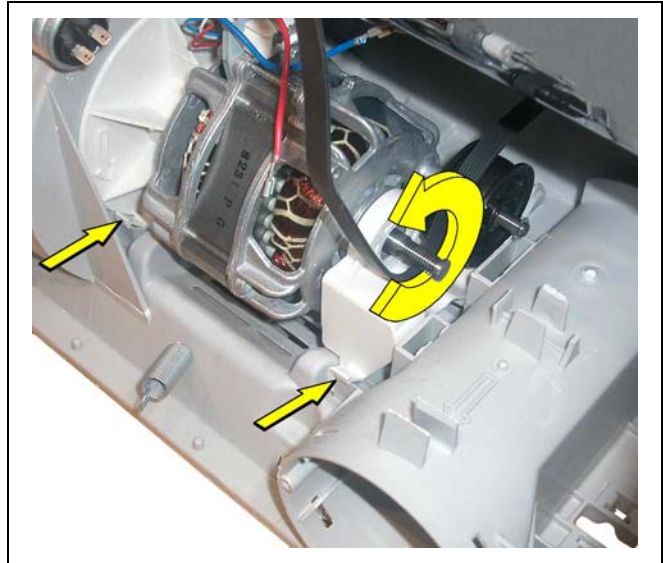

13.17.1 Notes for reassembly of the belt tensioning roller / belt.

1. Spacer.
2. Belt tensioning roller with integrated spacer.
3. Snap ring.
4. Belt.
5. Leave two grooves free on both sides of the pulley.

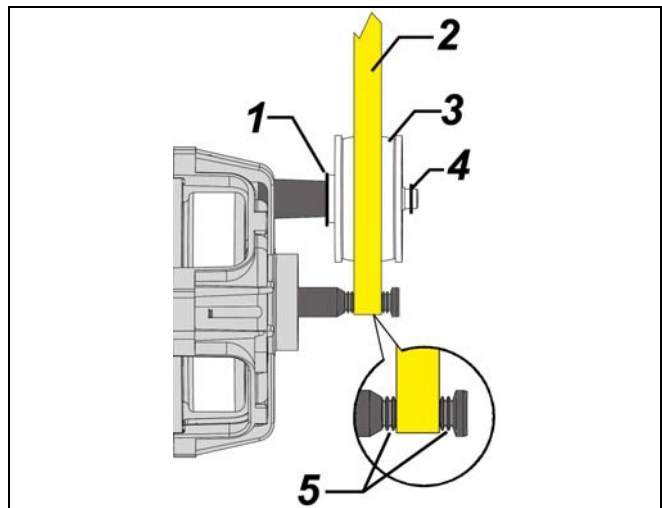

13.18 Rear brush (only on models with conductivity sensor)

1. Unfasten the screw fixing the drum pin guard.
2. Turn the guard anticlockwise until the lower fixing clip is free.
3. The brush is housed inside the drum pin guard.

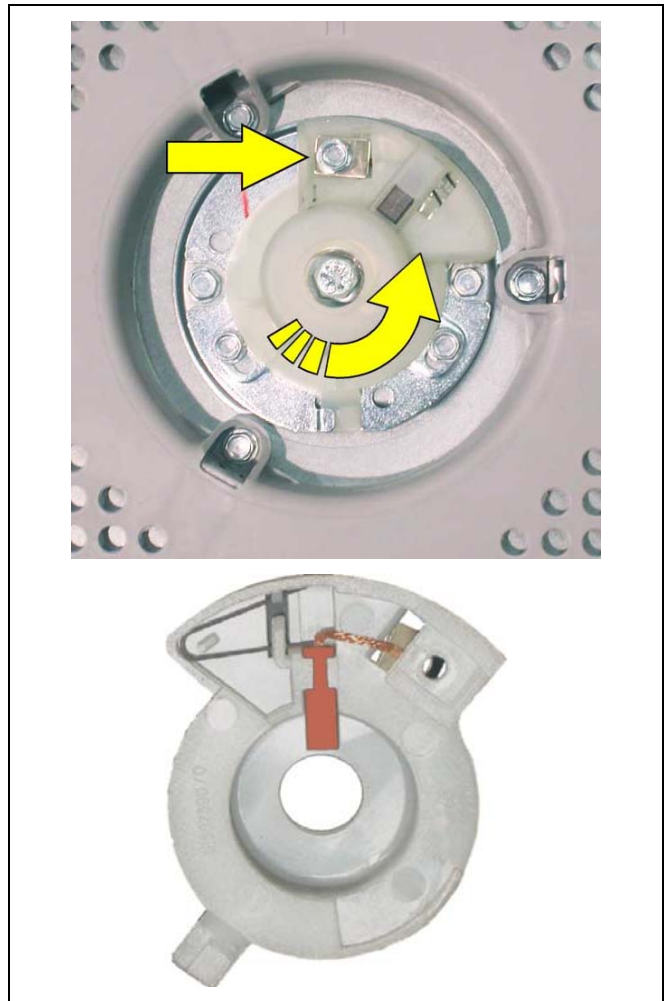

13.19 Front brush (only on models with conductivity sensor)

1. Remove the worktop (see paragraph).
2. Disconnect the wires.
3. With the aid of a screwdriver, press on the locking clip and at the same time remove the entire brush unit.

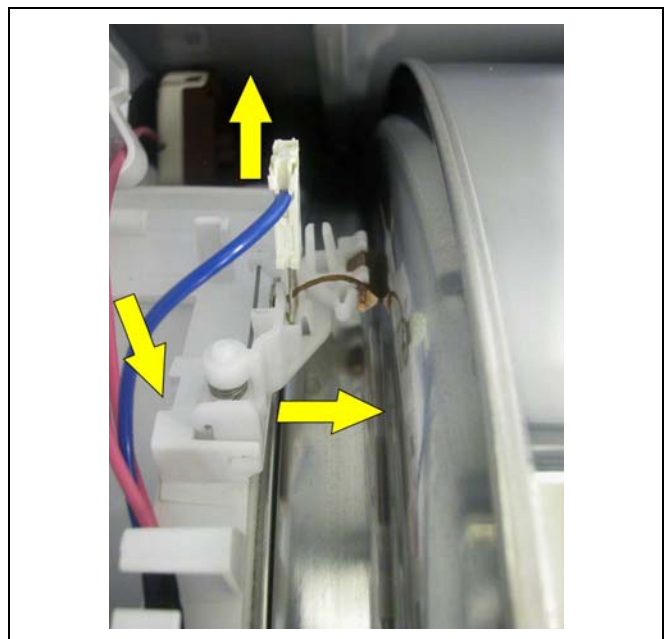

13.20 Back panel

1. Remove the worktop (see paragraph).
2. Remove the sides (see paragraph).
3. Unhook the tensioning spring.
4. In models with conductivity sensor, unfasten the screw fixing the rear brush unit.
In models with temperature probes, unfasten the screw fixing the pin guard.
5. Unfasten the screw fixing the bush to the drum pin (models with conductivity sensor only).

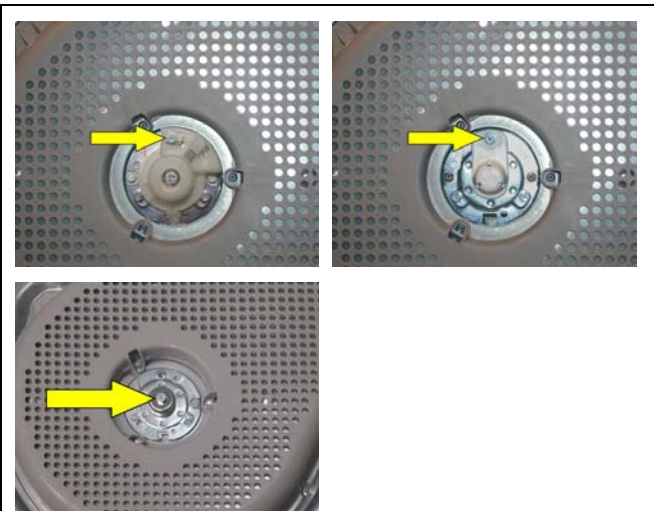

6. On all models, use a screwdriver to remove the snap ring and the spacing washer.

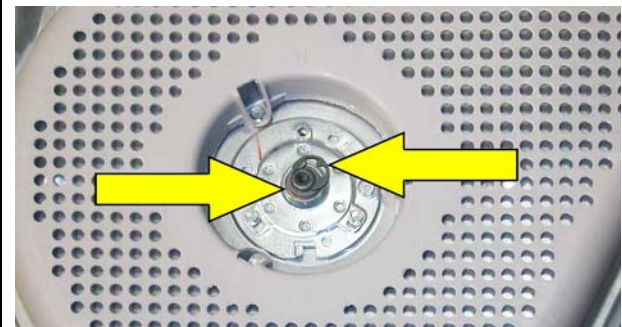

7. Disconnect the heating unit junction box (see paragraph).
8. Disconnect the anti-disturbance filter connectors (see paragraph).
9. Unfasten the 4 screws fixing the back panel to the base, and the 2 screws fixing it to the crossbars.
10. Remove the back panel, taking care that the drum does not fall.

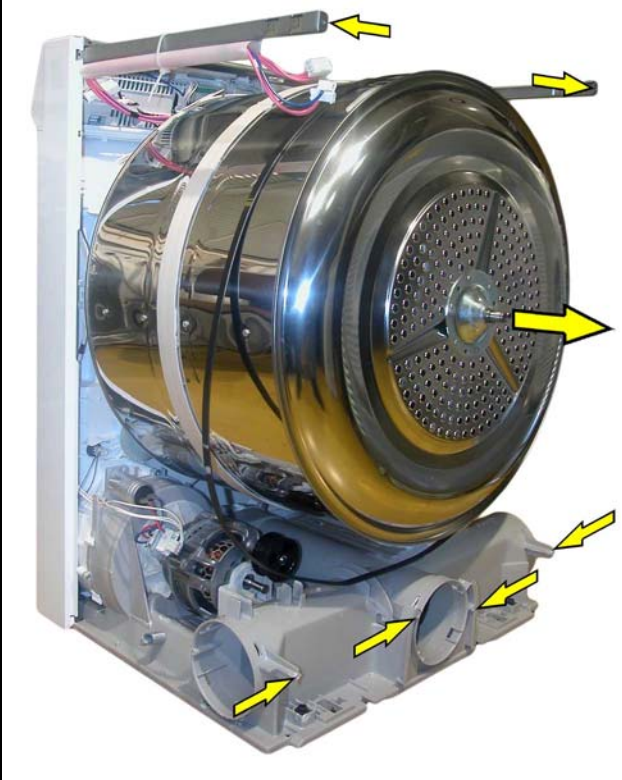

13.21 Belt

1. Remove the worktop (see paragraph).
2. Remove the sides (see paragraph).
3. Remove the belt tensioning spring.
4. Remove the back panel (see paragraph).
5. Take out the belt.

13.22 Drum

1. Remove the worktop (see paragraph).
2. Remove the sides (see paragraph).
3. Remove the belt tensioning spring.
4. Remove the back panel (see paragraph).
5. Take out the drum

13.23 Conduit rollers

1. Remove the worktop (see paragraph).
2. Remove the back panel (see paragraph).
3. Take out the drum (see paragraph).
4. Unfasten the screws fixing the rollers to the air conduit.

Never take out the rollers without removing the drum!
This operation may severely damage the roller fixing bush mounted in the air conduit.

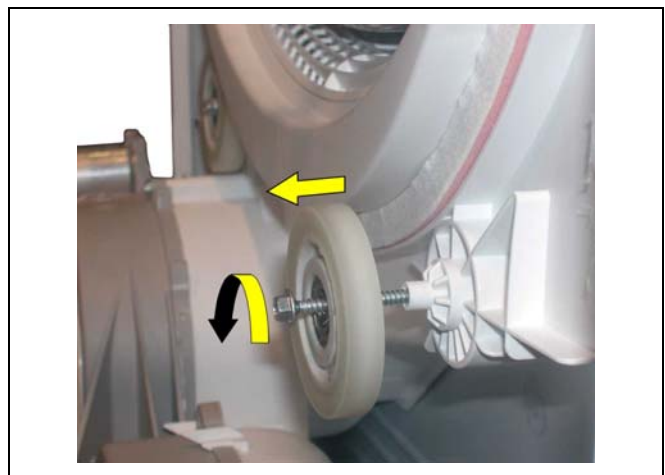

13.24 Rear air seal

1. Remove the worktop (see paragraph).
2. Remove the sides (see paragraph).
3. Remove the belt tensioning spring.
4. Remove the back panel (see paragraph).
5. Open the air seal fixing hooks slightly and take the seal out.

When fitting the new seal, take care to ensure that the seam is located in the lower part of the ring.



13.25 Front air seal

1. Remove the worktop (see paragraph).
2. Remove the back panel (see paragraph).
3. Remove the drum.
4. Take out the front air seal.

When fitting the new air seal, take care to ensure that the seam is located in the lower part of the conduit.



14 REVERSING THE DOOR

1. Unfasten the screws fixing the hinges to the unit (1), remove the door.
2. Unfasten the screws fixing the hinge covers (2) and fix them where the door hinges used to be (1).
3. Remove the worktop.
4. Remove the left and right sides.
5. Remove the front opening plug (4) bearing in mind that to extract it you have to press the hooks fastening it to the unit towards each other.
6. Unfasten the screws fixing the door lock (3) to the unit and extract the door lock.

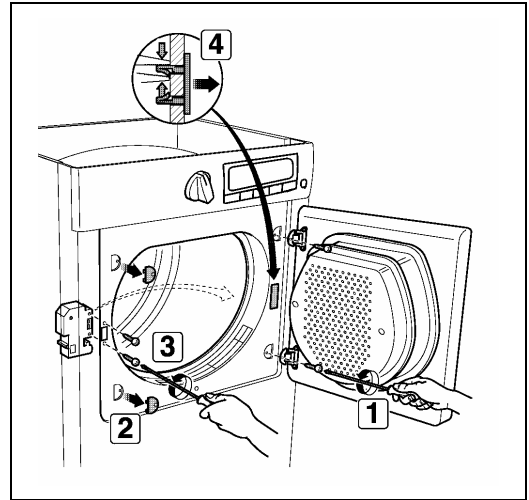

7. Disconnect the connector from the door lock.
8. Remove the tape (if there is any) holding the wires and separate the door lock wires from the other wires.
9. Replace the tape as you found it (on the other wires).

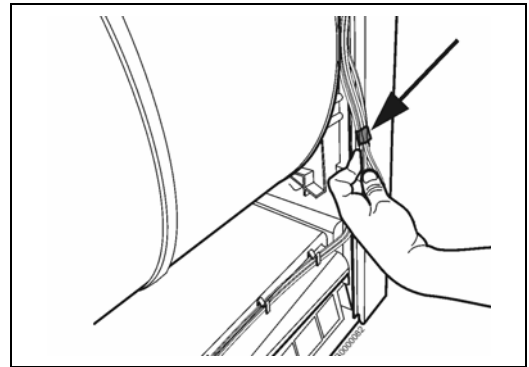

10. Insert the general wires into the hooks located in the air conduit, and arrange them so that they are parallel to the front and are unable to come into contact with the drum.
11. Lock the wires to the hook using a cable clamp.

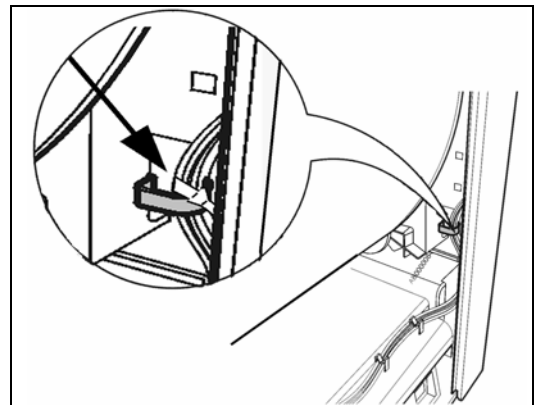

12. Remove the door lock wires from their original position (1) and insert them under the front brush (2), fixing them in the hooks in the conduit (3) and pulling the wires out at the opposite side of the unit.
13. Fasten any excess door lock cable to the cable guard (6), using a cable clamp.

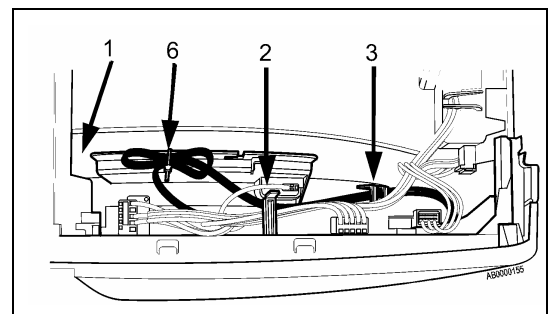

14. Insert the door lock connector and fasten it to the front with the screws (5), making sure that the wires are not crushed between the door lock and the front.
15. Check that the wires are properly inside all the hooks from which the door lock wires have been extracted.
16. Insert the front opening plug at the point in which the door lock (4) was previously located.

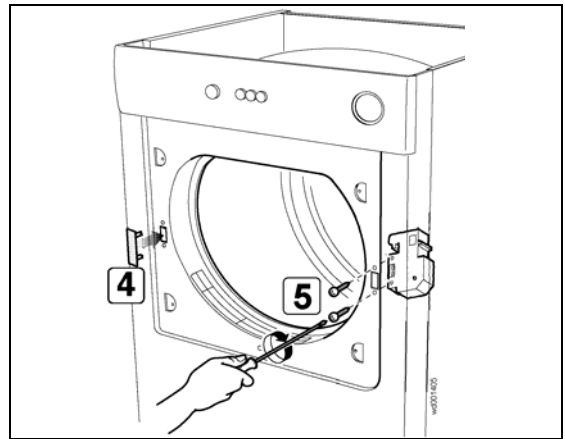

17. Remove the hinges after first removing the screws (6).
18. Remove door hinge covers (7).
19. Take out the door latch cover (8).
20. Take out the door latch (9) (see paragraph).

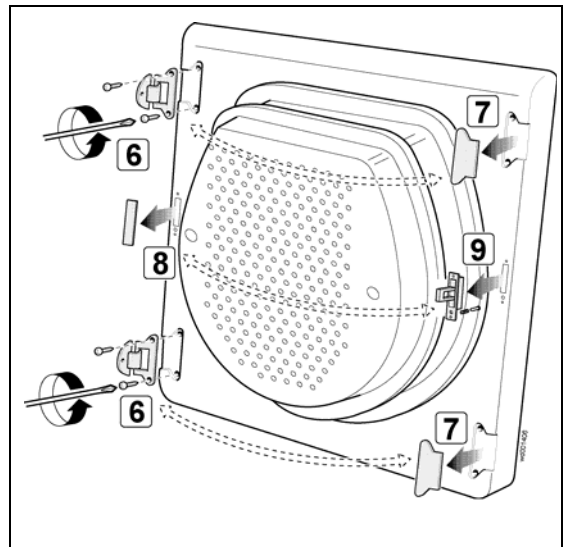

21. Insert the snap-on hinge covers (7).
22. Insert the door latch cover (8).
23. Insert the door latch (9).
24. Fix the hinges with screws (6).

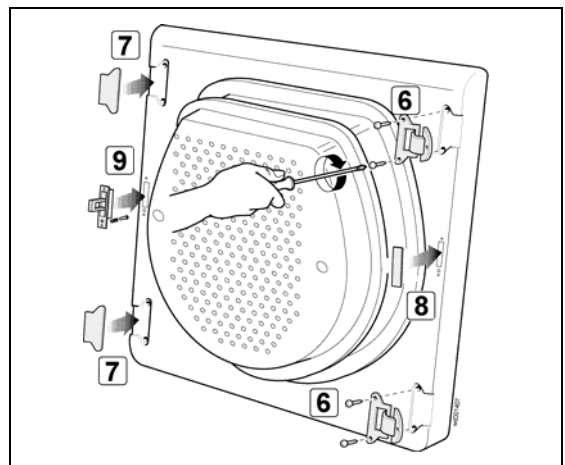

25. Position the door on the opposite side of the tumble dryer and fix the hinges with screws (10).
26. Replace the left and right sides (replace the fixing screws in their original positions, otherwise the earthing connection will be broken).
27. Replace the worktop.
28. Replace the "Push-Push" sticker.

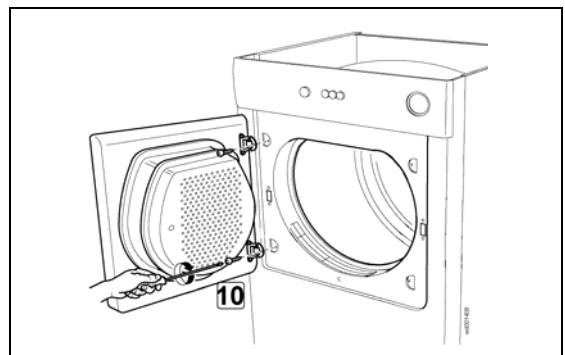

15 Final testing of door fastening

To check whether door fastening complies with safety regulations after the door has been reversed, proceed as follows:

prepare a loop (1) (of string, thread, etc.),
position it around the latch, close the door.

Check the door opening safety load as follows:

fasten a dynamometer to the loop (2),
then pull the instrument perpendicular to the surface of
the door. The scale should indicate:

MAX. 51 NEWTON (kg 5.1)

min. 38,2 NEWTON (kg 3.8).

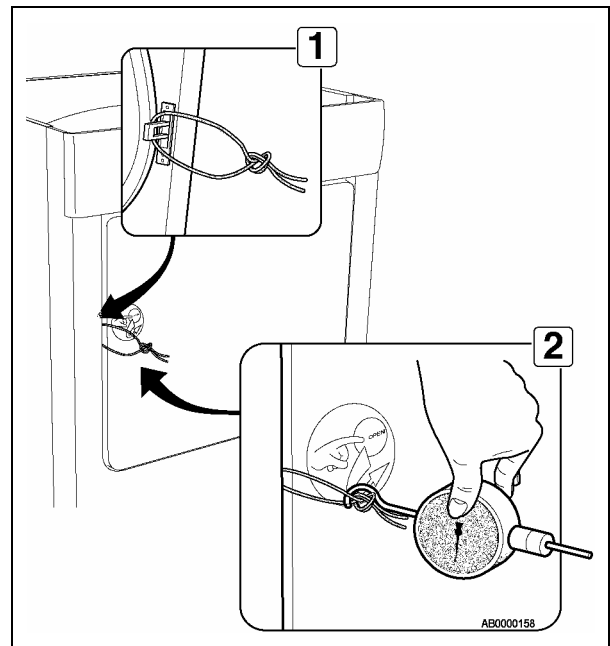

N.B.: This locking system has been designed to allow a child who has accidentally been shut inside the tumble dryer to open the door simply by pushing it. The appliance complies with current regulations.