

© Electrolux Home Products Italy  
S.P.A  
Corso Lino Zanussi, 30  
I-33080 Porcia - PN -

Fax 0039 - 0434 394096

SOI

Edition: 01/2009 Rev 0.0

Publication no.

**599 71 49 26**

EN

**Condenser dryer with  
electronic control  
Inverter motor**

**ENV06 AEG**

# CONTENTS

1	INTRODUCTION .....	5
1.1	Purpose of this Manual .....	5
1.2	Important.....	5
1.3	Installation.....	5
2	TECHNICAL CHARACTERISTICS.....	6
2.1	Technical data .....	6
2.2	Electronic boards .....	7
3	CONTROL PANEL.....	8
3.1	Stylings .....	8
3.2	Programme selector .....	8
3.3	Pushbuttons.....	9
3.4	Symbols on stylings with LCD .....	10
3.5	Child safety (on some models) .....	11
3.6	Delicate ½ power (on some models) .....	11
3.7	Spin speed regulation .....	12
3.8	Delayed start button.....	12
3.9	No buzzer .....	13
3.9.1	“NO BUZZER” (not only for the affected cycle) .....	13
3.10	Adjusting the level of conductivity .....	14
3.10.1	Procedure .....	14
3.10.2	Displaying the conductivity setting .....	15
3.11	Warning LEDs.....	15
3.12	START / PAUSE button.....	16
4	Description of operation of the appliance.....	17
4.1	Operation of a cycle.....	17
4.2	Operation in PAUSE mode .....	18
4.3	Operation in DELAYED START mode.....	19
4.4	Power failure.....	19
5	CONSTRUCTIONAL FEATURES .....	20
5.1	Drying circuit.....	20
5.2	Constructive parts.....	21
5.3	Drum .....	22
5.4	Air seals and drum shaft supports .....	22
5.5	Hydraulic circuit (versions with upper canister) .....	23
5.6	Drum rotation .....	23
6	Electrical components.....	24
6.1	Main electronic board .....	24
6.1.1	Electronic board functions .....	24
6.1.2	Memory of the electronic control : general structure.....	25
6.1.3	Inverter motor control board .....	26
6.2	Conductimetric sensor .....	27
6.3	Suppressor .....	27
6.4	Heater unit .....	28
6.5	NTC sensor.....	29
6.6	Canister filling pump (models with canister in upper section).....	29
6.7	Motor.....	30
6.8	Door switch .....	31
6.9	Door interlock.....	31

7	Electrical circuit .....	32
8	DIAGNOSTICS SYSTEM .....	33
	8.1 Access to diagnostics .....	33
	8.2 Exiting the diagnostics system.....	34
	8.3 Selector positions for diagnostics on conductimetric appliances.....	35
9	ALARMS .....	37
	9.1 Displaying the alarms to the user .....	37
	9.1.1 Alarm display during normal operation .....	37
	9.2 Reading the alarm codes.....	37
	9.2.1 Displaying the alarm code on all models .....	37
	9.3 Cancelling the last alarm memorized.....	38
	9.4 Notes concerning certain alarm codes .....	38
	9.5 Table of alarms .....	39
10	NO ACCESS TO DIAGNOSTICS PROGRAMME .....	41
	10.1 No LEDs on the display board light. ....	41
	10.2 Some of the LEDs on the display board light.....	43
11	ACCESSIBILITY TO COMPONENTS .....	44
	11.1 Door .....	44
	11.2 Lower fluff filter .....	44
	11.3 Door interlock.....	45
	11.4 Microswitch door .....	45
	11.5 Door interlock catch and micro door catch .....	45
	11.6 Drum light .....	46
	11.7 Canister .....	46
	11.8 Work top .....	47
	11.9 Control panel support and control panel assembly.....	48
	11.10 Main electronic board .....	49
	11.11 Motor control board.....	50
	11.12 Rear panel cover.....	51
	11.13 Heater unit .....	52
	11.14 Lower brush conductimetric sensor .....	53
	11.15 Rear brush .....	53
	11.16 Floating microswitch .....	54
	11.17 Float .....	55
	11.18 Pump.....	55
	11.19 NTC sensor.....	56
	11.20 Front air duct cover (hot air circulation) .....	57
	11.21 Rear air duct cover (cold air circulation) .....	57
	11.22 Drum rotation motor .....	58
	11.23 Capacitor (heat exchanger) .....	59
	11.24 Front flap.....	59
	11.25 Rear panel .....	59
	11.26 Drive belt.....	60
	11.27 Duct.....	61
	11.28 Duct rollers.....	61
	11.29 Front and rear seals.....	61
12	Reversibility of the door .....	62



# 1 INTRODUCTION

## 1.1 Purpose of this Manual

The purpose of this Service Manual is to provide service engineers who already have the basic knowledge necessary to repair dryers with information concerning condenser dryers with electronic control systems.

The electronic control consists of a main board having an integrated selector and on some models a LCD display, supplied already mounted and tested by the building factory.

This Service Manual describes the following aspects:

- General characteristics.
- Control panel and drying programmes.
- Description of operation.
- Drying circuit.
- Electrical components.
- Diagnostics guide.
- Accessibility.

## 1.2 Important

	<ul style="list-style-type: none"><li>- Repairs to electrical appliances must be carried out only by qualified service engineers</li><li>- Before touching internal components, always remove the plug from the power socket.</li></ul>
--	---

## 1.3 Installation

- The appliance must be installed on a perfectly level surface in order to ensure that the condensed water flows correctly into the tank.
- The feet must NOT be removed. The gap between the bottom of the dryer and the floor is essential to prevent overheating.

## 2 TECHNICAL CHARACTERISTICS

### 2.1 Technical data

Dimensions of appliance	Height: Width: Depth:	85 cm 60 cm 58 cm
Power supply	Volt: Hz.	220 - 240 50/60
No. Buttons	7	
No. LEDs	Depending on the model	
Type of display	Small LCD on TC3 models. Big LCD on TC2 models	
Buzzer	Buzzer incorporated in the PCB.	
Serial port	DAAS-EAP protocol up to 230400 baud.	
Programme selector	15 positions models with small LCD 21 positions models with big LCD	All models with integrated ON/OFF switch
Drying system	Condensation of humidity by heat exchanger.	
Humidity control	Conductimetric sensor.	
Motor	Inverter.	
Power of heater unit	Version 220 - 240 V 2200 W 1400 W + 800W	
Temperature control	NTC sensor.	
Tank capacity	Condensation tank ca 4l.	
Canister fill pump	Synchronous motor.	

## 2.2 Electronic boards

The electronic control consists of a main board having an integrated selector, a LCD display, supplied already mounted and tested by the building factory.

The pictures of the boards can differ slightly from the ones mounted on the appliances.

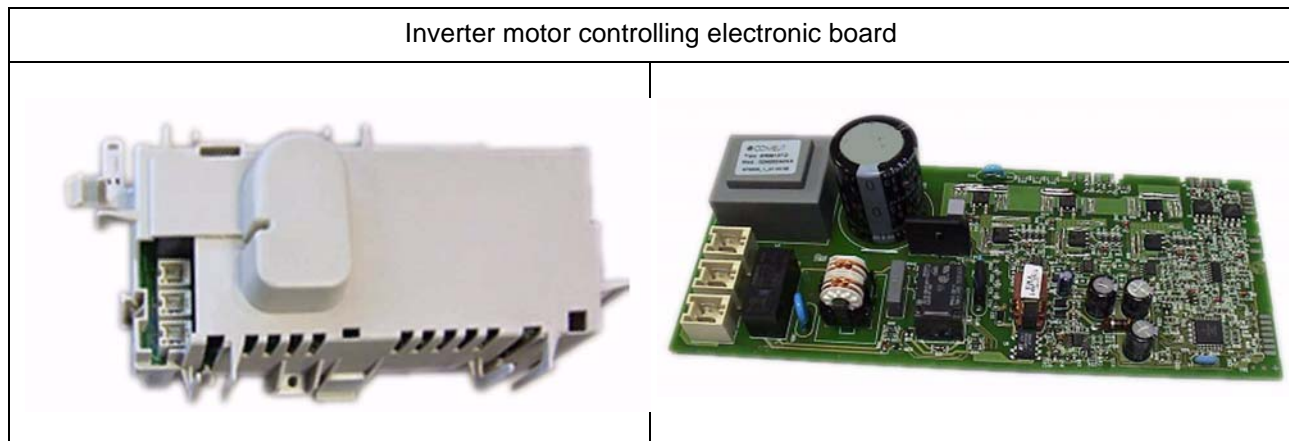
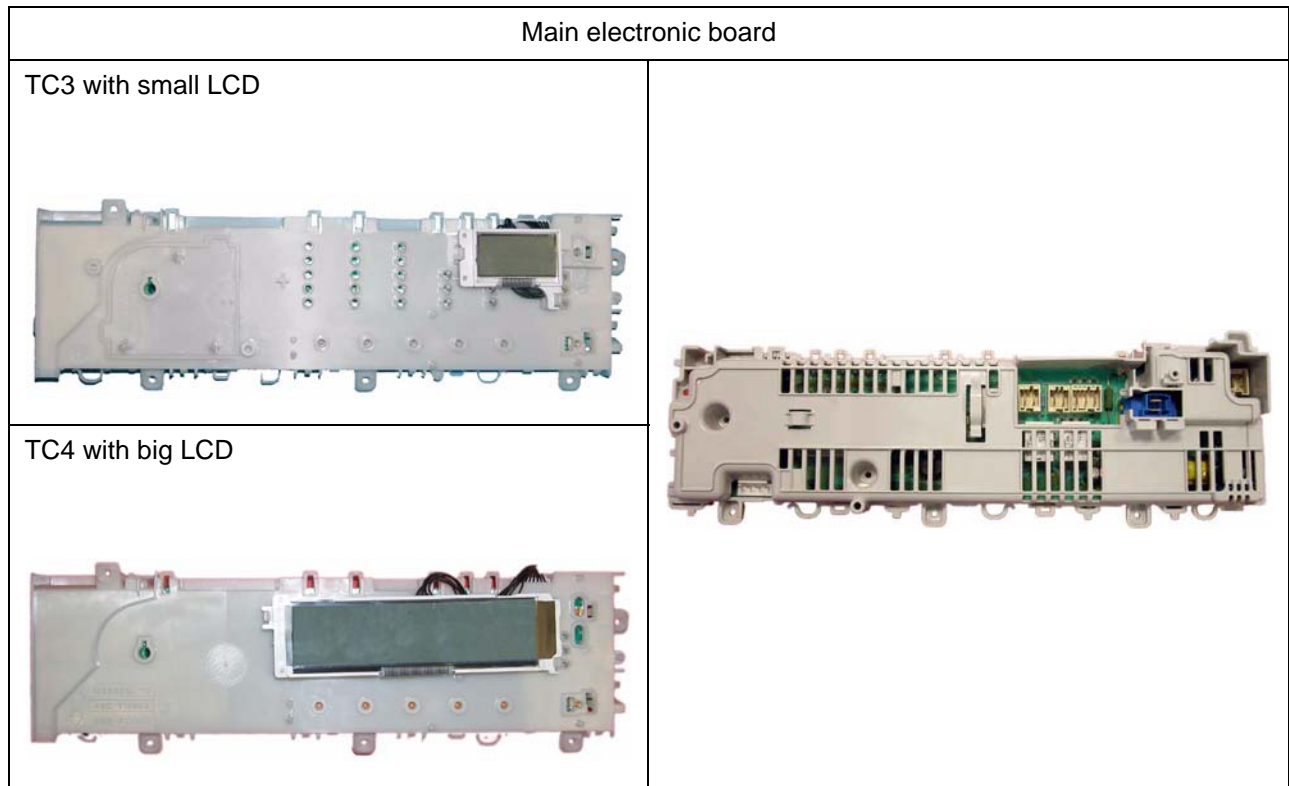

### 3 CONTROL PANEL

#### 3.1 Stylings

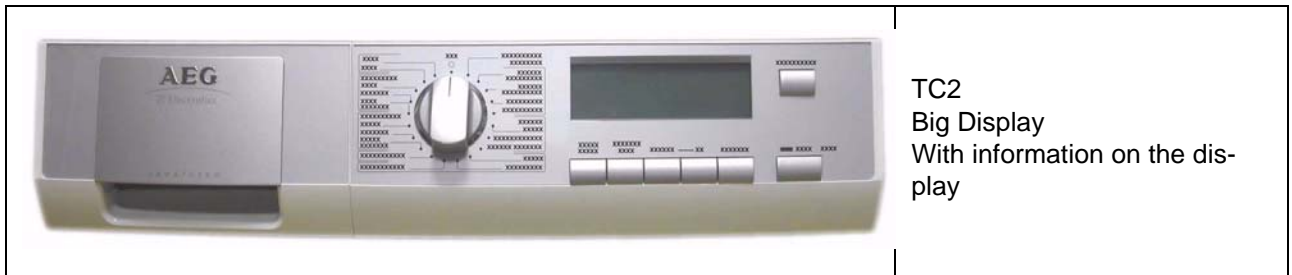

#### 3.2 Programme selector

The 15-position selector on models with small LCD (TC3), and 21 positions on models with big LCD (TC2) feature an integrated ON / OFF switch and are integrated in the board.

The symbols represent the various drying types for the different fabrics COTTON, SYNTHETICS, SILK, WOOL and TIMER.

All positions are configurable depending on the model





### 3.3 Pushbuttons

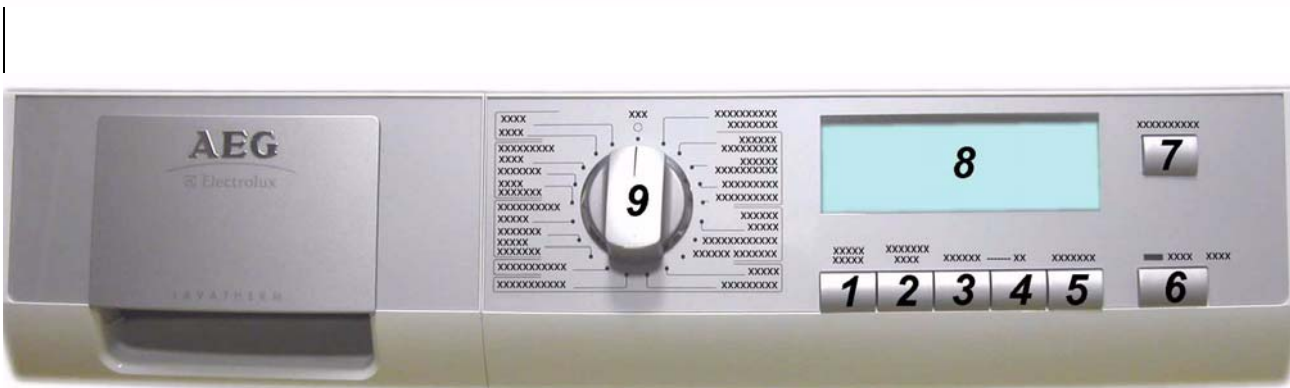
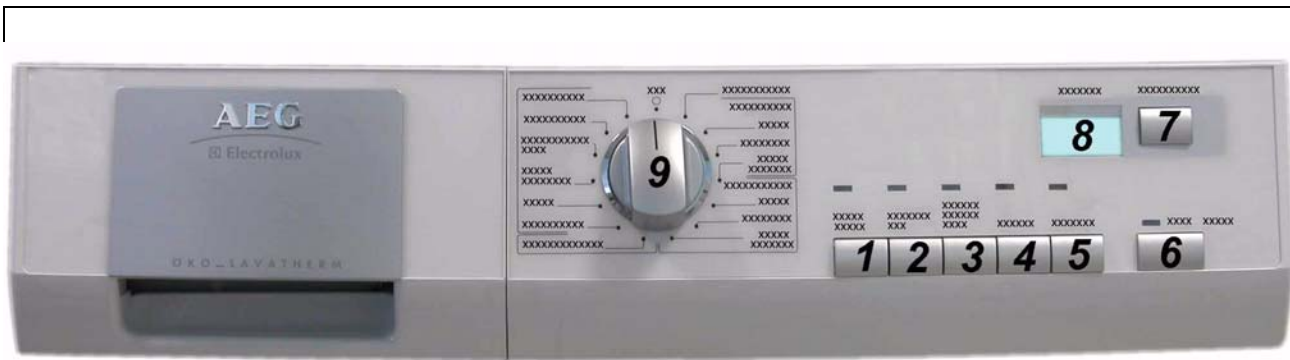

<p>1) Configurable button</p> <p>2) Configurable button</p> <p>3) Configurable button</p> <p>4) Configurable button</p> <p>5) Configurable button</p>	<p>6) Start / Pause button</p> <p>7) Delayed start button</p> <p>8) LCD</p> <p>9) Programme selector</p>
---	--

### 3.4 Symbols on stylings with LCD

Cycle options icons			
	Delicate		Long anti-crease phase
	Sensitive		Spin speed (washing machine)
	Final humidity level		
Cycle icons			
	Iron ready		Cupboard dry
	Light drying		Strong Drying
	Extra strong drying		Drying phase
	Cooling phase		Anti-crease phase
Alarms			
	Empty water collector		Clean filters
	Clean heat exchanger		Child Safety
	Buzzer		
Timer			
	Delayed start		Time-to-end / Alarm code

### 3.5 Child safety (on some models)

Pushing buttons 3 and 4 simultaneously for 5 seconds the child safety is activated, all buttons are deactivated and no modification is possible. To deactivate this protection, push the buttons previously pushed

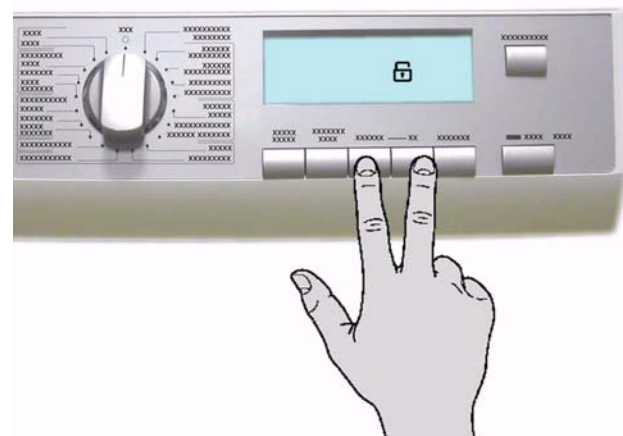
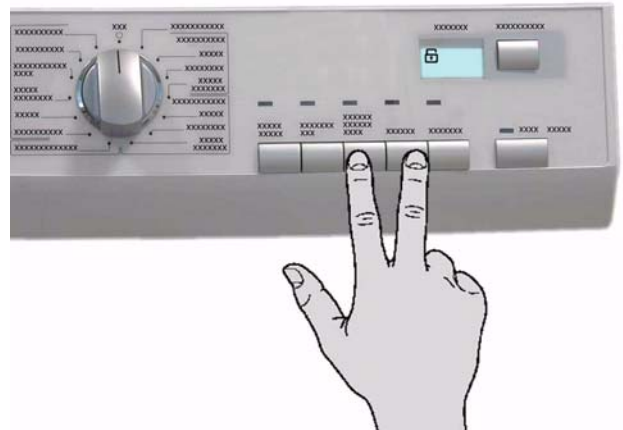

### 3.6 Delicate ½ power (on some models)

This dryer features a heating group with two separate heating elements whose power varies according to the model.

When this pushbutton is pressed once, the electronic control system switches off the lower-power heating element, and the corresponding LED lights to indicate that the option has been selected; if the pushbutton is pressed again, the LED switches off to indicate that the option has been deactivated, and the heating element switches on again during the cycle.

### 3.7 Spin speed regulation

With this regulation the electronic circuit receives the information that the spin has occurred at a certain speed and the clothes consequently have a certain humidity degree.  
On some programmes this value modifies the time necessary to the final drying.  
Each time the button is pressed, the value increases by 200 rpm, from a minimum of 800 rpm till a maximum depending on the chosen programme; the maximum value is 1800 rpm.  
To reset this value, push repeatedly this button

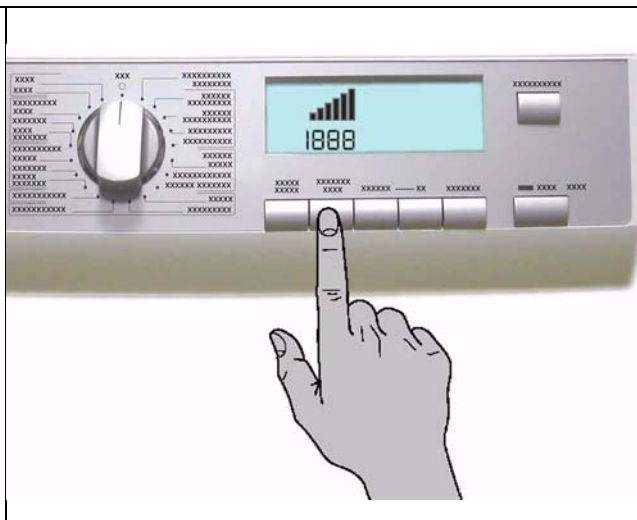

### 3.8 Delayed start button

Pushing this button, it is possible to select, during the programme selection phase, a delayed start.  
The time varies up to a maximum of 20 hours; the time is shown on the Display  
Each time the button is pressed, the delay time increases:

- For the first two hours, the time increases by half an hour.
- After the first two hours the time increases by one hour.
- To reset the delay time either move the selector by one position or push the button till the Display is reset.

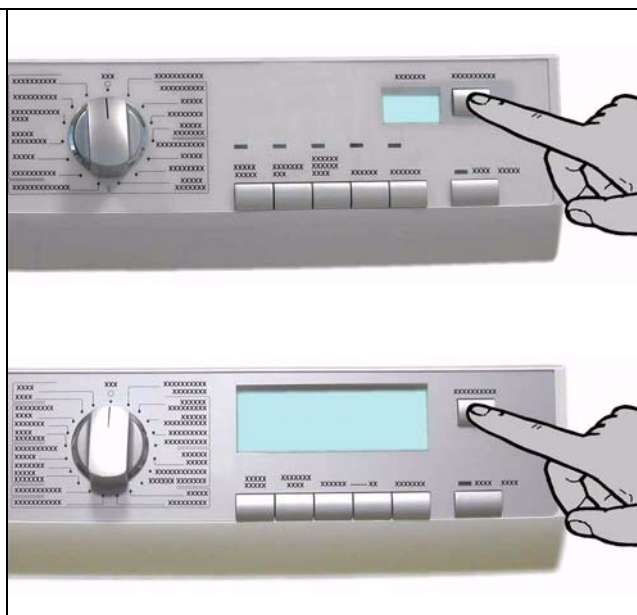

This option must be selected after choosing the programme and before pushing START/PAUSE button.

### 3.9 No buzzer

This option can be selected only when the dryer is in "selection" mode (set-up).

Press this pushbutton to deactivate the buzzer function: the activation is signalled by the switching on of the LED or of the icon. To deactivate the option push button

Even when the buzzer function is deactivated, the buzzer will continue to signal an alarm condition.

#### 3.9.1 "NO BUZZER" (not only for the affected cycle)

Setting to be made during the selection phase (set-up):

On all models push buttons 1 and 2 simultaneously for five seconds, the LED or the icon representing the buzzer will deactivate and a "beep" will be heard.

To reset the buzzer press the pushbutton combination above described until the buzzer emits a "beep".

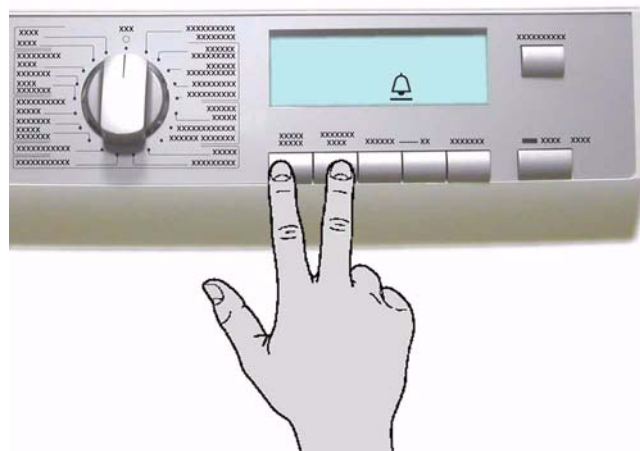

### 3.10 Adjusting the level of conductivity

The “conductivity” of the water used to wash the fabrics varies from zone to zone: the conductimetric sensor is calibrated to a standard value; any major variations in the level of conductivity may affect the final drying result (i.e. the washing may be too dry or too humid):

These variations can be noticed above all in “slightly humid” or “iron ready” cycles; the “cupboard dry” cycles are not affected by the variations of the conductivity.

#### 3.10.1 Procedure

To access adjustment mode:

1. Turn the programme selector to switch on the appliance.
2. In selection mode (set-up), simultaneously press the following buttons:

- 1 and 5 on models with big LCD.
- 1 and 5 on models with small LCD.
- 1 and 4 on models with small LCD and alarm LEDs
- 1 and 3 (start/pause) on models without LCD

3. Continue to hold down the buttons until the buzzer sounds (about 5 seconds).

Adjusting the level of conductivity:



Press the START/PAUSE button sequentially: the conductivity level varies and is signalled by the switching on of the LEDs or of the horizontal segments of the last digit.

Memorizing the new setting:

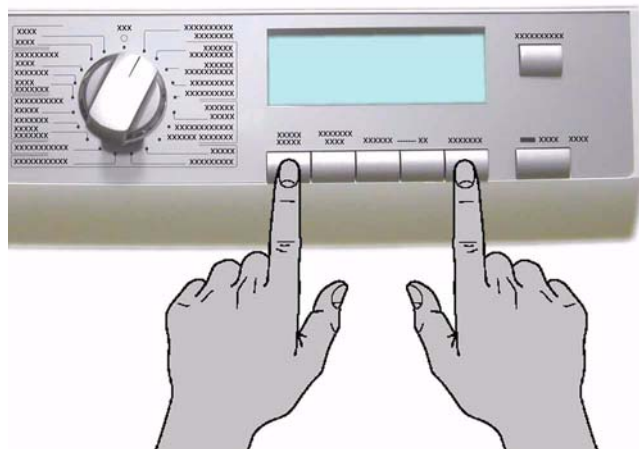
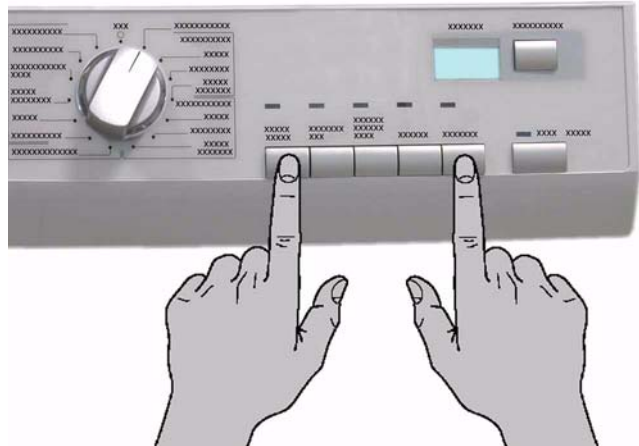
1. Simultaneously push the buttons previously pushed.
2. Hold down the buttons till the buzzer sounds (about 5 seconds).



### 3.10.2 Displaying the conductivity setting

Display LED	Conductivity level	Indicative value ( $\mu\text{S/cm}$ )
	LOW	< 300
	MEDIUM	300 - 600
	HIGH	> 600

Normally, the appliance is factory-set to the highest level; however, certain models may be configured differently.

Your local water supply company can give you information concerning the conductivity of the water in your area.

### 3.11 Warning LEDs



Heat exchanger cleaning:

Lights after 80 drying cycles

To reset the cycle counter (for this function), open the door with appliance on, extract the heat exchanger, clean it and then close the door



Filter cleaning:

Lights when the dryer has completed the cycle to remind the user to clean the fluff filter



Canister full:

Lights during the drying cycle if the electronic circuit detects the closure of the floating microswitch, or at the end of the cycle to remind the user to empty the canister.

## START/PAUSE:

Lights with a green flashing light when the cycle is in pause; lights with a fixed green light when the cycle is performing. If there is an alarm, three beeps will be emitted and they will be repeated after some seconds and the LED will flash with a red light.

### 3.12 START / PAUSE button

- Start

When a drying programme has been selected using the programme selector, the icons of the three phases (drying, cooling, anti-crease) light and the START/PAUSE LED flashes.

After selecting the options, press this button to start the cycle, the relative LED remains lit.

- Pause

If START/PAUSE is pressed while a drying cycle is being performed, the dryer interrupts the cycle and the appliance goes to PAUSE mode; the corresponding LED flashes.

Press START/PAUSE again to resume the cycle from the point at which it was interrupted.

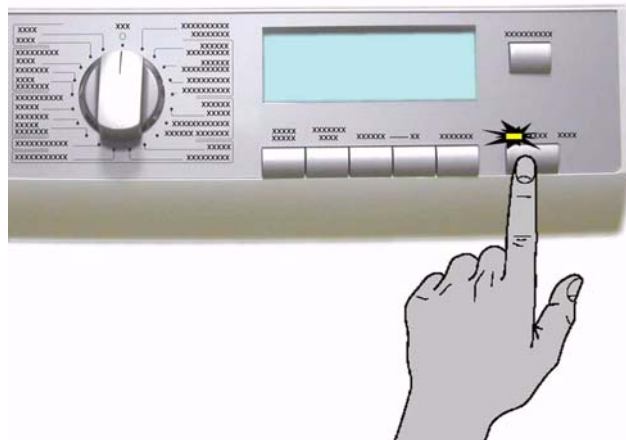
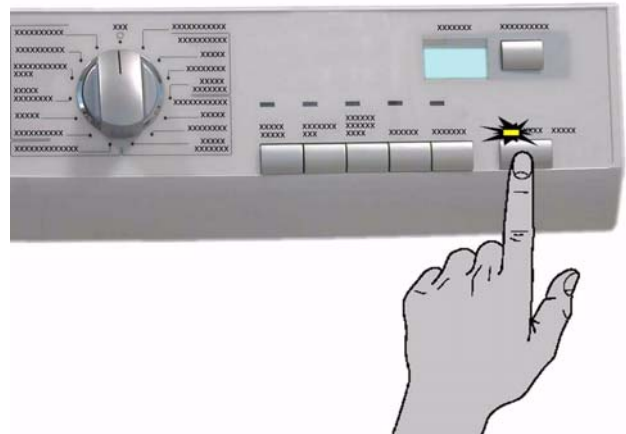



## 4 Description of operation of the appliance

When the selector is turned from OFF position to a drying programme, the icons relative to the drying phases light up and the START/PAUSE LED flashes with green light.

During this phase the various options can be entered, and the corresponding LEDs will light.

The lower right display shows the maximum time of drying cycle. If an option that is incompatible with the selected cycle is entered, the Buzzer sounds, the Display shows Err. The LEDs instead flash

Selecting one or more options the Display shows an increase or decrease of the time. If the position of the selector is changed after choosing the options, but before pressing START/PAUSE button, the options will be cancelled.

### 4.1 Operation of a cycle

A drying cycle starts after a programme has been selected using the selector, one option (if necessary) has been selected and the START/PAUSE button has been pressed.

The LED corresponding to the START/PAUSE button remains lit with green light and, at the same time, the LED corresponding to the phase currently being performed lights and the display shows the maximum drying time.

The drying cycle consists of the following phases:

- **DRYING**  
If the cycle is automatic, its duration will be the time necessary to remove the humidity until the desired degree of final humidity is reached (maximum cycle time 180 minutes at full power and 240 minutes at half power).  
If the cycle is timer-controlled, the duration will be the time selected by the user.
- **COOLING**  
For timer-controlled cycles, the maximum duration of the cooling phase is 10 minutes; for automatic cycles the duration depends on the temperature inside the drum.
- **ANTI-CREASE**  
The duration of the anti-crease cycle is 30 minutes.

No modifications to the programmes can be entered after the drying programme has started

If the position of the selector is changed, the green LED of the START / PAUSE button starts flashing, the buzzer sounds to warn the user that an incorrect operation has been attempted and the display shows Err.

If any button is pressed, the green LED of the START / PAUSE button starts flashing, the buzzer sounds to warn the user that an incorrect operation has been attempted and the display shows Err.

The options can be selected only after selecting a drying programme at the beginning of the cycle, or during a cycle after pressing the START/PAUSE button.

To cancel a drying cycle, it is necessary to turn the programme selector to OFF.

## 4.2 Operation in PAUSE mode

If START/PAUSE is pressed while a drying cycle is being performed, the dryer interrupts the current cycle, the green LED of the START / PAUSE button flashes and the display shows time to end.

If the selector is turned, the buzzer warns the user of the error.

In this situation, only certain options can be modified, see tab. of Options.

If the button relative to an option that cannot be selected is pressed, the buzzer sounds to warn the user of the error and the display shows Err. When START/PAUSE is pressed again, the drying cycle resumes from the point at which it was interrupted.

### 4.3 Operation in DELAYED START mode

After selecting a drying cycle, press this button to enter the delayed start option. Every time the button is pressed the delay time increases.

To cancel this option move the selector of one position or press the button till the time is cancelled. The start of the cycle is always determined by pressing the START/PAUSE button.

### 4.4 Power failure

The table below shows how the dryer behaves in the event of a power failure during a drying cycle.

Before the power failure	After power is restored
Set-up	Set-up
Drying cycle	Pause
Cycle paused	Pause
Anti-crease phase	End of cycle
Delayed-start cycle	Delayed start cycle paused
Delayed start cycle paused	Delayed start cycle paused
End of cycle	End of cycle
"Canister full" alarm	"Canister full" alarm

## 5 CONSTRUCTIONAL FEATURES

### 5.1 Drying circuit

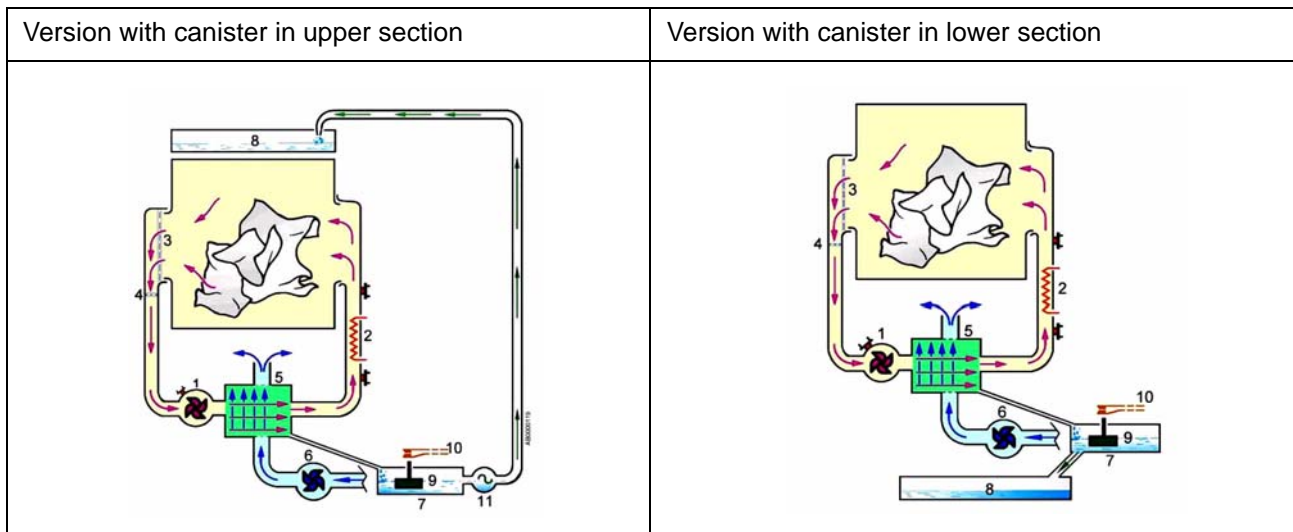

There are two air circuits inside the dryer:

- the first is a warm-air circuit, which is sealed within the appliance
- the second is an open cold-air circuit, which circulates air from the ambient through certain sections of the appliance

In the sealed warm-air circuit, the air circulates inside the appliance:

The fan (1), ducts the air through a heat exchanger (5), and then to the heater unit (2). The heater unit heats the air, which is then ducted into the drum through the perforations in the rear flange of the drum. The warm, dry air passes through the wash load, which is agitated by the rotation of the drum, and removes the humidity from the fabrics; the air, which is now warm and humid, passes then through the front aperture of the drum via the fluff filter (3) and the lower filter (4), then the air is ducted by the fan (1) to the heat exchanger (5), where the humidity is condensed. The air coming from the heat exchanger is now dry and the cycle continues as described above.

The cold-air circuit (the air circulates in one side of the appliance) is not sealed:

the fan (6) draws in air through an air intake on the rear of the appliance, and ducts the air to the heat exchanger (5), cooling it, after which the air is expelled on the opposite side of the heat exchanger dissipating inside the appliance and exiting from the venting grille in the plinth.

The warm and cold air circuits cross inside the heat exchanger (5), which results in a thermal exchange which condenses the humidity contained in the warm air.

The condensation water, which forms in the heat exchanger, is collected in a sump (7) which contains a float (9):

- In versions with the canister in the upper section, a pump (11) ducts the water from the sump (7) to the canister (8). When the canister is full, any overflow is collected in the canister support and returned through a tube (not shown in the figure) into the sump (7). This causes the float (9) to rise, thus actioning the microswitch (10).
- In versions with the canister in the lower section, the water flows by gravity from the sump (7) into the canister (8); when the canister is full, the water level in the sump (7) rises. This causes the float (9) to rise, thus actioning the microswitch (10).

The electronic control system detects the closure of the microswitch, cuts off the power to the appliance and switches on a LED warning the user that the canister is full.

The tank capacity is about 4 lt., which is sufficient for one drying cycle.

## 5.2 Constructive parts

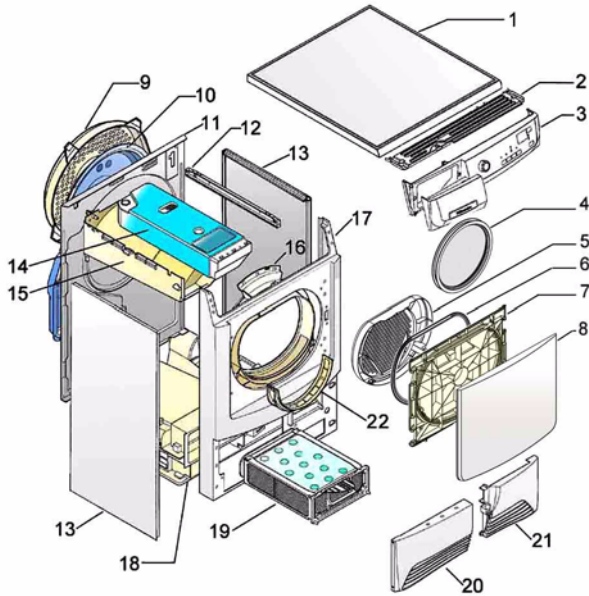
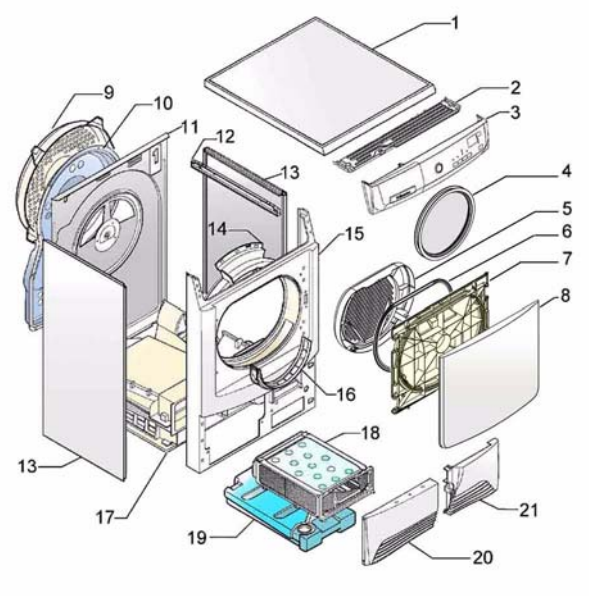
Upper tank version	Lower tank version
	
<ol style="list-style-type: none"> <li>1. Work top</li> <li>2. Control panel support</li> <li>3. Control panel</li> <li>4. Fluff filter</li> <li>5. Fluff filter support</li> <li>6. Door seal</li> <li>7. Door internal frame</li> <li>8. Door external frame</li> <li>9. Rear panel cover protection</li> <li>10. Rear panel cover</li> <li>11. Rear panel</li> <li>12. Cross-member</li> <li>13. Side panels</li> <li>14. Upper tank</li> <li>15. Tank support</li> <li>16. Duct</li> <li>17. Front panel</li> <li>18. Base</li> <li>19. Heat exchanger</li> <li>20. Panel</li> <li>21. Plinth</li> <li>22. Front fluff filter</li> </ol>	<ol style="list-style-type: none"> <li>1. Work top</li> <li>2. Control panel support</li> <li>3. Control panel</li> <li>4. Fluff filter</li> <li>5. Fluff filter support</li> <li>6. Door seal</li> <li>7. Door internal frame</li> <li>8. Door external frame</li> <li>9. Rear panel cover protection</li> <li>10. Rear panel cover</li> <li>11. Rear panel</li> <li>12. Cross-member</li> <li>13. Side panel</li> <li>14. Duct</li> <li>15. Front panel</li> <li>16. Lower fluff filter</li> <li>17. Base</li> <li>18. Heat exchanger</li> <li>19. Lower canister</li> <li>20. Panel</li> <li>21. Plinth</li> </ol>

The front panel and the side panels are in enamelled sheet metal, while the rear panel is in zinc-plated sheet metal; these parts are fitted with self-tapping screws to the base.

The shaped carboran base houses the main components.

### 5.3 Drum

The drum consists of a drum housing where the two flanges are crimped, the rear one with a hole that allows the air to flow through and the other open to allow the insertion of the clothes.

Inside the drum there are 3 drum lifters which during the normal operation let the clothes move around.

Externally there is a metallic band, where the brush wipes, electrically isolated from the drum by means of an isolating band

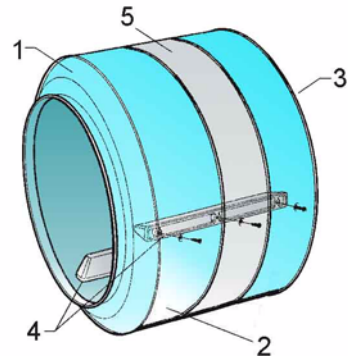

- 1. Front flange
- 2. Drum housing
- 3. Rear flange
- 4. Drum lifters
- 5. Brush contact band

### 5.4 Air seals and drum shaft supports

#### Rear air seal

- 1. Rear seal (fitted to the rear panel)
- 2. Drum
- 3. Rear panel

#### Rear drum support

- 4. Anti-clutching washer
- 5. Fixing ring (Benzing)
- 6. Rear panel
- 7. Drum spindle
- 8. Support with bushing (fitted to the rear panel)

#### Front drum support and air seal

- 9. Drum
- 10. Felt ring with tubular support
- 11. Duct

#### Lower drum support

- 9. Drum
- 10. Felt ring with tubular support
- 11. Duct
- 12. Drum support roller

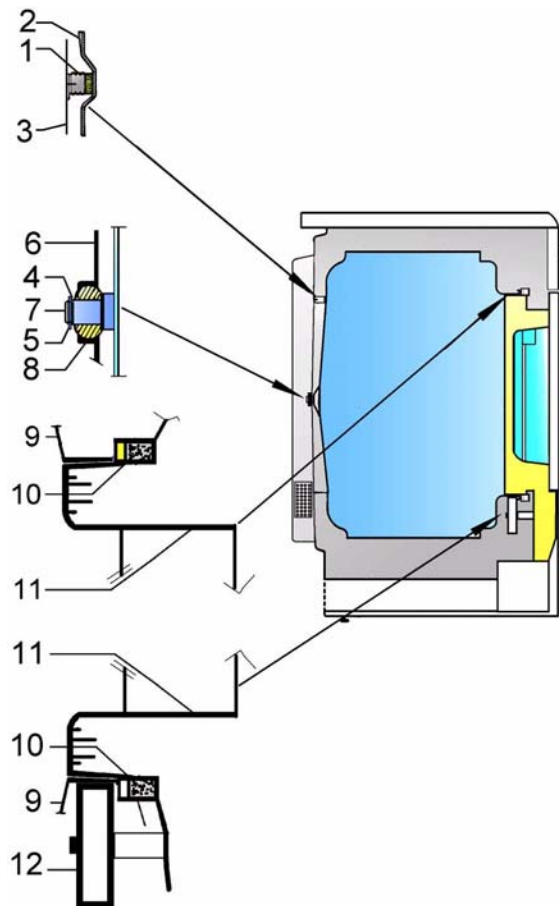

## 5.5 Hydraulic circuit (versions with upper canister)

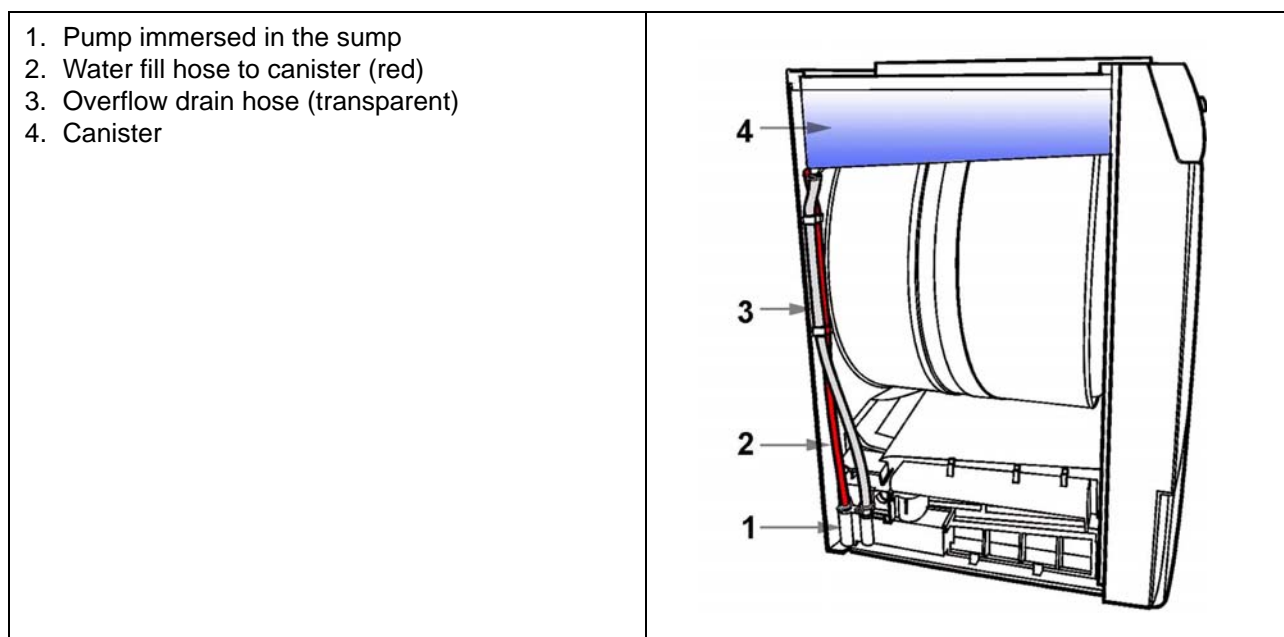

The condensation water is ducted from the sump (1) to the tank (4) by the pump immersed in the sump via the hose (2). When the canister is full the overflow is collected in the canister support and ducted to the sump through the hose (3).

## 5.6 Drum rotation

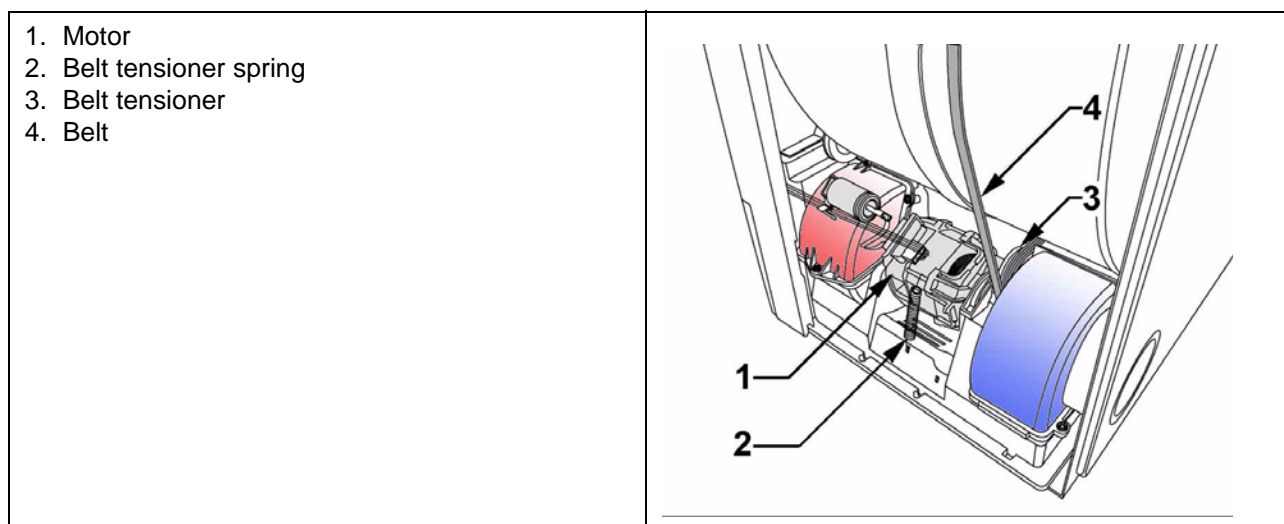

The drum is rotated by a belt (4), which is driven by the pulley of the drum motor (1) fitted to the base; on the bearing shield there is a belt tensioner (3), which has the function of increasing the winding angle of the belt to the drum and works in conjunction with the belt tensioner spring (2).

Bidirectional operation of the drum rotation is determined by the electronic board which inverts the motor power direction for brief periods. Reversal of the direction of rotation allows the clothes to unroll. During these short periods, the heater unit is switched off.

The heat exchanger features a safety device which ensures that, if the panel is opened to check the heat exchanger, a microswitch disconnects the dryer from the power supply.

## 6 Electrical components

### 6.1 Main electronic board

The electronic control consists of a main electronic board fitted into a plastic container, fixed behind the control support. In the models with LCD there is also the display board mounted on this container.

1. Main electronic board casing
2. Cover for connectors
3. Cover for selector
4. Selector pin
5. Button springing system

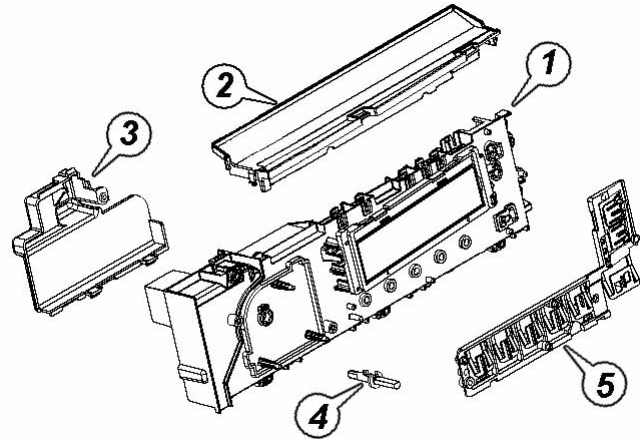

#### 6.1.1 Electronic board functions

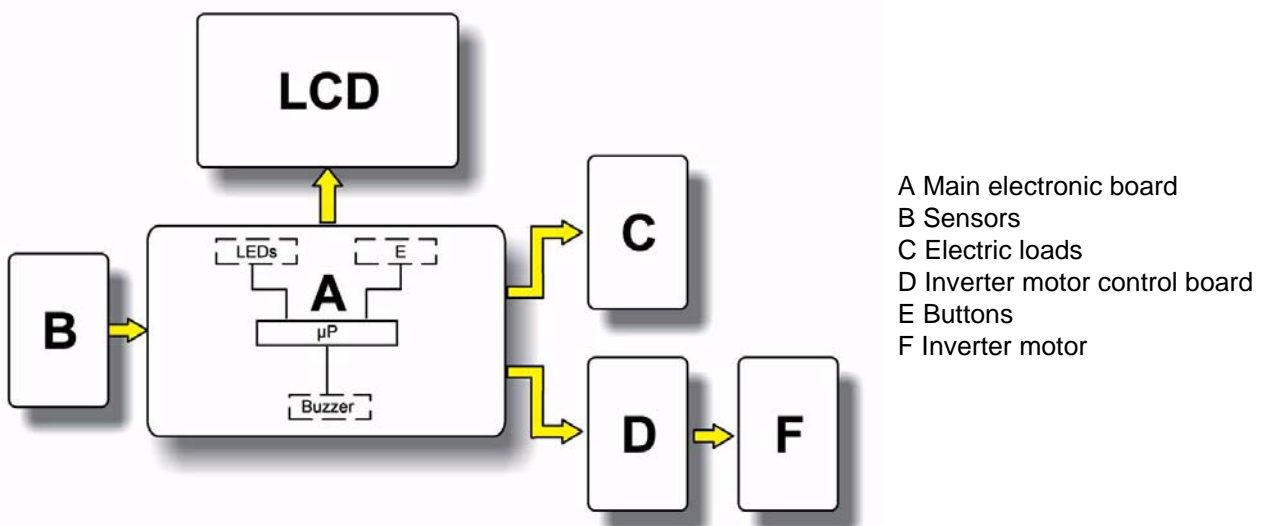

- The electronic board receives the controls relative to the drying cycle setting.
- The electronic board powers the main components: Pump (for dryers with canister in the upper section), heater and door interlock.
- The board also controls the door interlock, the temperature of the air inside the dryer (using an NTC sensor), the level of humidity of the washing (using a conductimetric sensor) and the level in the canister.
- Controls the Inverter board that activates the drum rotation motor.
- The buzzer is incorporated in the main board.



## 6.1.2 Memory of the electronic control : general structure

The main PCB features an EEPROM, positioned externally to the microprocessor, which memorizes the configuration data, the description of the cycle, the status of the appliance in case of a power failure, and the alarms.

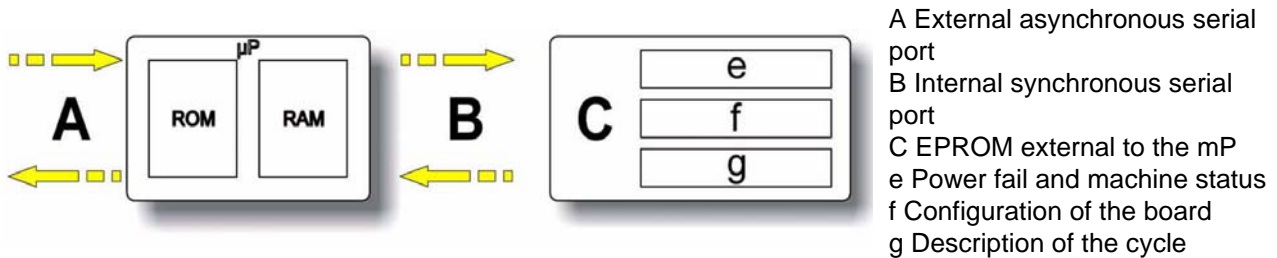

### ROM

This area of the memory contains the "firmware" code including the functionalities of the appliance

- Control of electrical loads (motor, pump, heater).
- Control of the sensors (NTC, conductimetric sensor, door switch status).
- Control of the user interface.
- Control of the serial port.
- Control of power failures and alarms.
- Alarms.

In standard-production appliances, this area is a Read-Only Memory, and thus cannot be modified.

### RAM

This memory contains the variables, i.e. all the dynamic information used during execution of the programme:

- Machine status.
- Cycle selected.
- Alarms.

The contents of this memory are cancelled each time the appliance is disconnected (by switching off or in the event of a power failure).

The contents can be read using a computer connected via a DAAS interface.

### EEPROM

The EEPROM contains data of various types:

- Power failure and machine status, i.e. the information necessary to resume operation of the appliance after a power failure.
- Configuration of the drying cycle: this file describes the various steps in the drying cycle for each family of appliances (vented, condenser etc.)
- Machine configuration: the data contained in this area of memory define the configuration of the individual appliance, and are interpreted by the functional software. These files define the following:
  - Programmes.
  - Number of buttons and their functions.
  - Operation of the LEDs.
  - Operation of the buzzer.
  - Operational limits (voltage/frequency)
  - Identification of the appliance (PNC + ELC + serial number)
  - Heater unit power.
  - Preferential direction of motor rotation.

### 6.1.3 Inverter motor control board

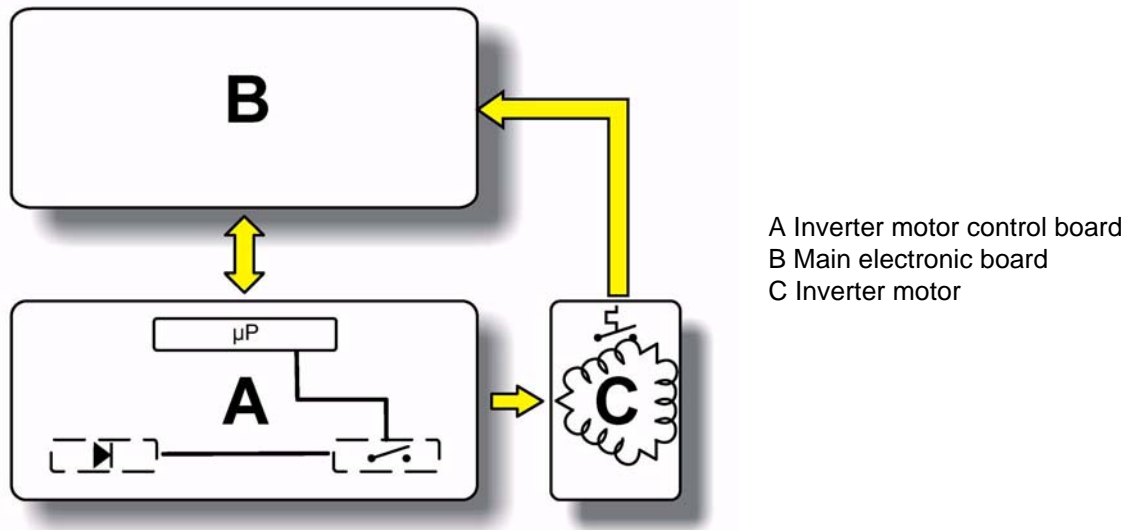

The Inverter motor control board controls the drum rotation motor and receives the clock pulses and the supply from the main board.

The thermal protection of the motor in case of operation interrupts the supply not directly on the motor, but through the main electronic board.

## 6.2 Conductimetric sensor

This electronic features a conductimetric sensor which consists of an electronic circuit (positioned inside the power board) and a section located externally to the board which consists of the wiring, two brushes, the two drum lifters and the drum.

The measurement of the resistance value occurs between the drum (1) and the isolated drum lifters (2).

This value varies according to the wash load, the type of fabric and the degree of humidity.

The brush (3) is in contact with the drum lifters by means of the contacts (5) fitted to the contact band (4) which is isolated from the drum by an insulating band.

The carbon brush (6) in contact with the drum pin is inserted into the drum pin protection (7).

This sensor is connected to the electronic circuit via the cabinet, which represents the mass of the appliance's electronic circuit. When the drum is empty, the impedance between the drum band and the sensor positioned on the drum lifters is infinite. The impedance value becomes measurable as soon as humid clothes are inserted. This value is between about  $1M \div 25M$  and is converted into an oscillation of between about 260Hz and 0Hz; when processed by the electronic circuit (fuzzy logic), this value determines the duration of the cycle and the final humidity.

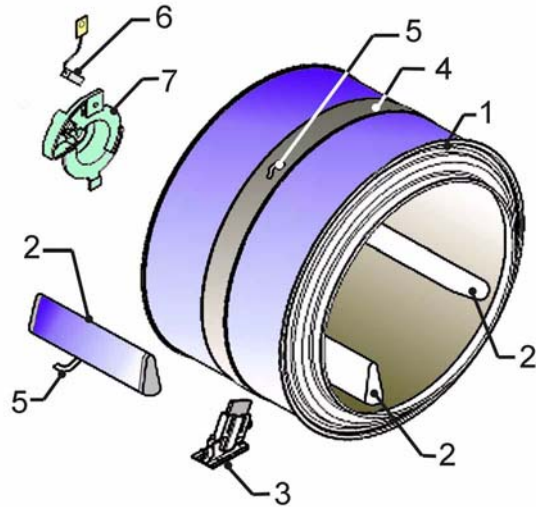

## 6.3 Suppressor

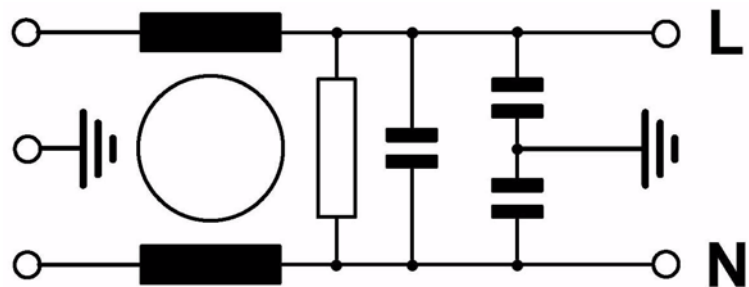

The suppressor, which is incorporated in the terminal block, prevents radio disturbance generated by the dryer from entering the power lines.

This device functions correctly only if the appliance is grounded.

## 6.4 Heater unit

- A Filament heating element
- B Ceramic supports
- C Sheet metal casing
- D TH2 Safety thermostat
- E TH1 Safety thermostat

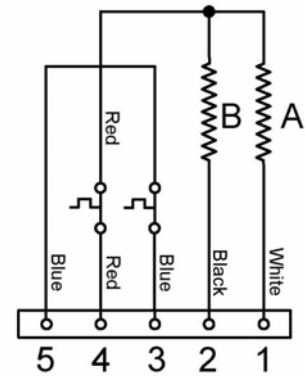
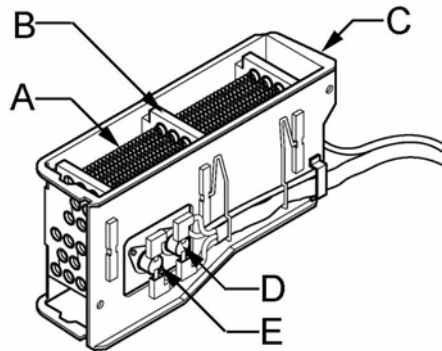

The heater unit consists of two wire heating elements with different powers. The two heating elements are fitted to ceramic supports, and the entire assembly is housed in a sheet metal casing.

Two safety thermostats (normally closed) are positioned to one side of the casing:

- TH1 automatic reset (4) intervenes at a temperature of  $92 \pm 3^\circ\text{C}$ , and disconnects both heating elements
- Thermostat TH2 (5) intervenes at  $160^\circ\text{C}$ ; when the contact opens, it remains open, permanently disconnecting all the electrical components in the appliance.

The heater unit is powered via two relays fitted to the board.

HEATER UNIT VERSIONS					
Type	Total power (-2 + 8% ) W Rated voltage V	2400 240	2400 230	2000 240	2200 240
Branch A	Power(-2 + 8% ) W Resistance $\Omega$	1400 36	1400 33	1400 36	1400 36
Branch B	Power(-2 + 8% ) W Resistance $\Omega$	1000 51	600 78	600 85	800 72

**Warning:** In the event of a thermostat failure, the entire heater unit must be replaced!

## 6.5 NTC sensor

The NTC sensor is fitted to the hot air fan duct. It consists of a heater, inserted inside a metallic capsule, which value diminishes with the increasing of the temperature. The electronic circuit reads the resistance (which varies with the temperature inside the dryer); when this resistance falls below a certain value, the heater unit is switched off. As the air cools, the resistance increases; when it reaches a given value, the electronic circuit re-connects the heater unit to the power supply. This occurs each time the temperature inside the dryer exceeds a given value, which varies according to the drying cycle that has been selected.

1. Terminals
2. NTC Resistor
3. Metallic capsule
4. Plastic casing

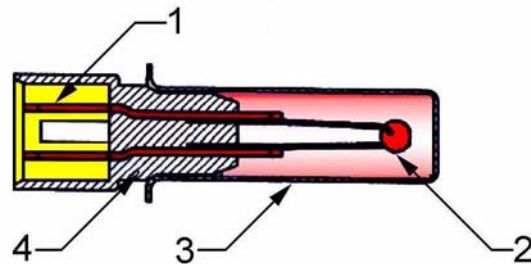

TEMPERATURE ( °C )	RESISTANCE ( Ω )		
	Rated value	Maximum value	Minimum value
20	6050	6335	5765
60	1250	1278	1222
80	640	620	660

## 6.6 Canister filling pump (models with canister in upper section)

The pump is actioned by a synchronous motor with a power of about 17W.

The function of the motor is to pump the condensation water from the sump to the canister.

The pump, too, is powered by a triac. The resistance of the stator winding is approximately 750 W.

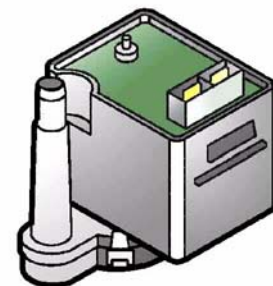

## 6.7 Motor

1. Fan (inclined blades for cold air circulation)
2. Belt tensioner
3. Motor
4. Fan (straight blades for warm air circulation)

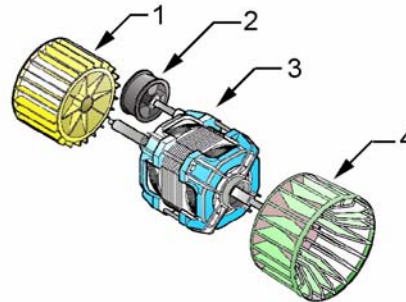

The motor group consists of a belt tensioner (2), two fan blades (1 and 4) for circulating cold and warm air respectively, fitted to the motor shaft using bolts, and a single-phase asynchronous motor (3) featuring a thermometric protector.



Attention:

When assembling the fan blades to the motor, do not reverse their positions, as this would cause incorrect air circulation inside the dryer.

- L Phase
- N Neutral
- A Inverter motor board
- B Motor
- C Condenser
- D Diodes
- I1 ÷ I6 Switches
- F1÷F6 Motor connectors
- μP Microprocessor

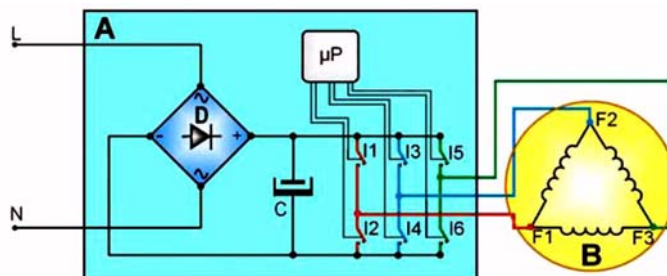

To transform the single-phase electric energy (available in our houses) into three-phase electric energy a new electronic board (A) is used, that transforms the energy from single to three-phase and can be modulated to regulate the power and the motor runs number.

The single-phase electric energy (applied to connectors L-N), is rectified from the diode bridge (D), therefore, across the condenser C there is a continuous voltage of 310V, which through the combination of the openings and closures of the switches I1 ÷ I6 (controlled by μprocessor) determines the controlling voltage and frequency of the motor.

The motor speed is controlled by means of the signal of the tachometric generator (T). During the drying phases, the microprocessor can control, according to the programme and the humidity of the fabrics, the speed and the rotation direction.

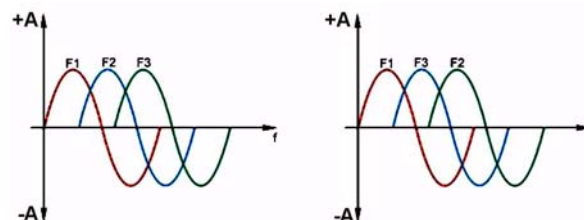

## 6.8 Door switch

The door switch allows the electronic board to power the electrical components only if the door is closed, if a programme has been chosen and the ON/OFF button has been pushed.

The switch is positioned centrally and above the front opening and it is actioned by a catch placed on the door.

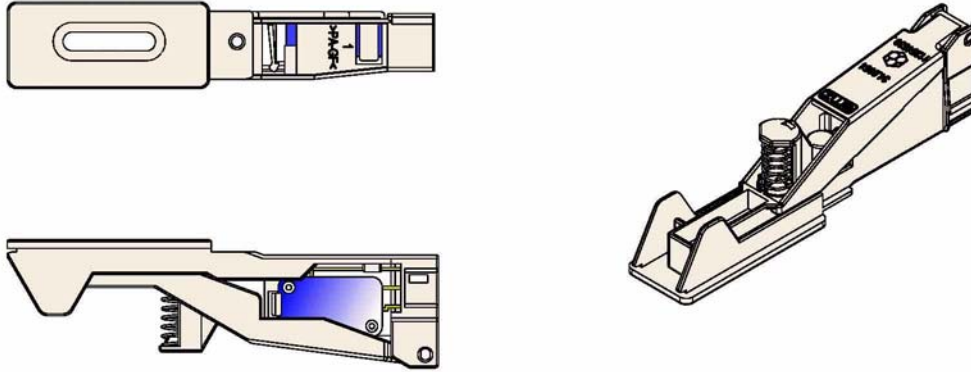

## 6.9 Door interlock

Depending on the versions, the door interlock can be mechanical with manual door opening or electronic with door opening by pushing a button. In the latter case, the door is opened by an electromagnetic coil which unlocks the door catch by means of a lever.

The interlock features a child safety device so that, in case of necessity, the door can be opened by pressing from inside the appliance.

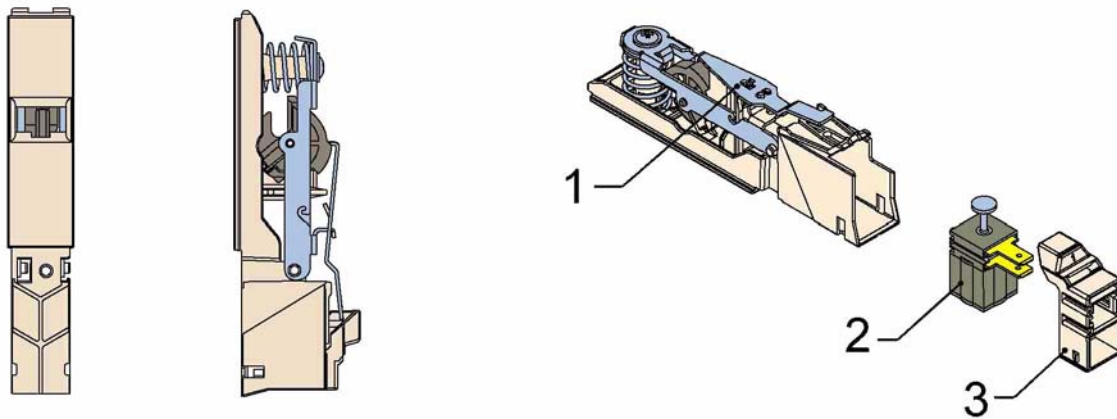

1. Catch door lever
2. Coil (in versions with automatic opening)
3. Coil protection

# 7 Electrical circuit

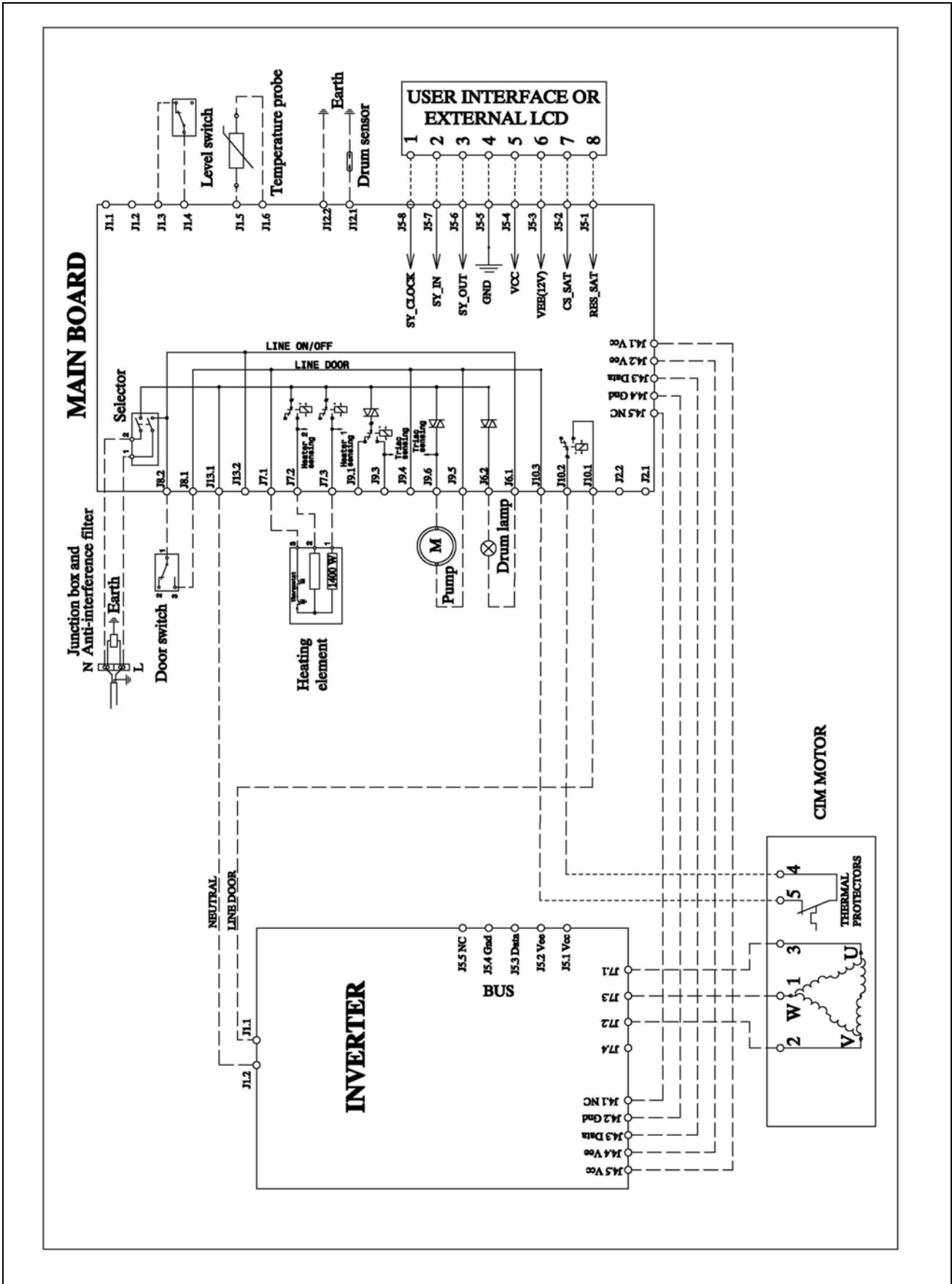



## 8 DIAGNOSTICS SYSTEM

In diagnostic mode, it is possible to check the operation of the appliance and to read the alarm codes

### 8.1 Access to diagnostics

1. The appliance must be switched OFF.
2. Switch the appliance ON by turning the programme selector knob one position clockwise.
3. Wait till the LEDs switch on and the “beep” of the buzzer, then push the buttons simultaneously depending on the model.  
ATTENTION THIS OPERATION MUST BE CARRIED OUT WITHIN 5 SECONDS
4. Continue to hold down the buttons until the LEDs begin to flash and the buzzer sounds.

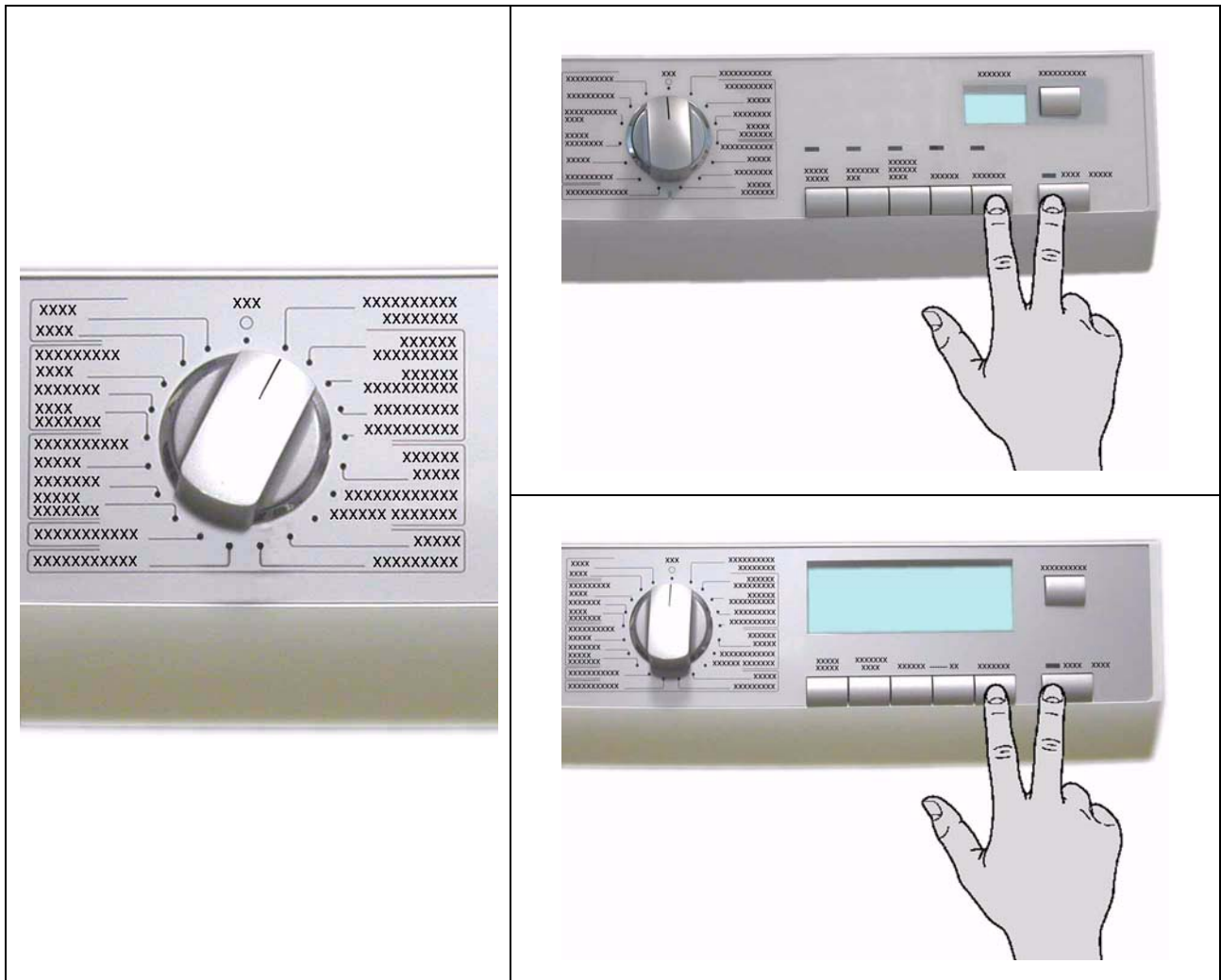

## IMPORTANT

- The alarms remain active during component diagnostics testing. If an alarm should be displayed, turn the programme selector to the first position to exit the alarm situation, and then continue the testing cycle (if the alarm is not repeated).
- In order to check for correct operation of the floating switch and the pump, the sump is filled with approximately 0.7 litres of water.
- For correct control of the conductimetric sensor in a condition of short-circuit (position 7), remove the cover and create a short-circuit between the two half-shells of the drum or between the front shell and ground. After entering this phase, the time available for creation of the short circuit is just one second; therefore, prepare the short circuit before turning the programme selector knob to position eight (it is advisable to do this in a position in which the drum is stationary, then pass quickly to this position). If the short circuit is not performed correctly, the electronic board will display alarm E32 (sensor frequency too low). To exit the alarm condition, turn the programme selector knob to the first position.
- Open the condenser access panel and check that the switch operates correctly: the buzzer will emit four "beeps" (in different tonalities), repeated every 7 seconds.

## 8.2 Exiting the diagnostics system







To exit the diagnostics system, turn the programme selector knob to zero to switch the appliance OFF, then switch it ON and OFF again.





### 8.3 Selector positions for diagnostics on conductimetric appliances



ATTENTION

When the various functions in the diagnostic mode are entered, in the LCD models, in the right lower part of the display some writings appear (ex. C7 - C5 etc.). These represent the codification of the selector and are not relevant for the test being executed.

Position Selector	Active components	Operating conditions	Function checked
<p>1</p> 	<p>All the LEDs and digits light in sequence. When a button is pressed, the corresponding LED lights and the buzzer sounds.</p>	<p>Always active.</p>	<p>Operation of the user interface.</p>
<p>2</p> 	<p>Condensation canister level sensor. Canister fill pump.</p>	<p>Door closed. Sump full with about 0,7 litre water.</p>	<p>Operation of the floating switch and condensation canister fill pump.</p>
<p>3</p> 	<p>Drum rotation motor control board. Canister fill pump always powered.</p>	<p>Door closed. Maximum time 10 minutes Pump 30 seconds.</p>	<p>Control of counter-clockwise drum rotation.</p>
<p>4</p> 	<p>Drum rotation motor at low speed.</p>	<p>Door closed max time 10 minutes.</p>	<p>Control of clockwise drum rotation (low speed for visual inspection of drum shell assembly).</p>
<p>5</p> 	<p>Higher-power heating element. Drum rotation motor.</p>	<p>Door closed. Maximum time 10 minutes.</p>	<p>Control of correct drum motor direction and of operation of a part of the heating element.</p>
<p>6</p> 	<p>Full-power heating element. Clockwise drum rotation motor.</p>	<p>Door closed. Maximum time 10 minutes.</p>	<p>Control of correct drum motor direction and of operation of the heating element (full power).</p>

<p>7</p> 	<p>Conductimetric sensor with drum short-circuited. The check lasts 4 sec., 1 sec. to create the short circuit. The phase/warning LEDs flash during this period: if the result is correct at the end, the LEDs switch off; if not, the LEDs flash and alarm E32 is displayed.</p>	<p>Door closed. Short circuit between the 2 drum shells.</p>	<p>Control of the conductimetric sensor when short-circuited.</p>
<p>8</p> 	<p>conductimetric sensor. This check has a duration of 4 sec. The phase/warning LEDs flash during this period: if the result is correct at the end, the LEDs remain lit; if not, the LEDs flash continuously.</p>	<p>Door closed.</p>	<p>Control of the conductimetric sensor when the circuit is open.</p>
<p>9</p> 	<p>Floating switch. Canister fill pump: with switch closed.</p>	<p>Door closed. Maximum time 30 sec.</p>	<p>Operation of floating switch (sump empty).</p>
<p>10</p> 	<p>Reading/cancellation of the last alarm code. Turn the knob till position 10, paying attention not to stop to position 7, otherwise error 32 may occur.</p>		

## 9 ALARMS

### 9.1 Displaying the alarms to the user

Operation of the alarms is configurable according to the model. Some or all of the alarms may be displayed to the user.

Normally, all alarms except E61, E97, EH2 are displayed to the user.

When an alarm condition occurs, the drying cycle may be interrupted or paused; in some cases, for the sake of safety, a forced cooling cycle is performed. In this case, the electronic board, if possible, disconnects the power relay from the heater unit and powers the motor of the drum cooling fan. The cycle remains active until the user switches off the appliance.

#### 9.1.1 Alarm display during normal operation

On models with LCD the family of the current alarm is displayed to the user.

In the event of, for example, alarm E53 (communication problems between motor controlling board and main board), the code will be displayed as follows

- First digit: letter "E" (error)
- Second-third digit: the number "5 0", e.g. the alarm family E5E)

On all models the same alarm code is displayed by a repeated sequence of flashing of the START LED of RED colour (0.4 seconds on, 0.4 seconds off, with a pause of 2.5 seconds between sequences)



The five flashes indicate the first of the two numbers in the alarm code E5E (the alarms relative to the same function are grouped into families).

### 9.2 Reading the alarm codes

To read the last alarm code memorized in the EEPROM of the electronic board:

- Access diagnostic mode (see paragraph)
- Turn the programme selector clockwise to the tenth position in conductimetric models and to the eight position in temperometric models, paying attention not to stop in the other positions, because error 32 may occur)

#### 9.2.1 Displaying the alarm code on all models

The alarm code is displayed by a repeated sequence of flashing of the LED START (0.4 seconds on, 0.4 seconds off, with a pause of 2.5 seconds between sequences). The buzzer emits a series of "beeps" in synchronization with the flashing of the LEDs

START LED with RED light: indicates the first digit of the alarm code (family)

START LED with GREEN light: indicates the second digit of the alarm code (number inside the family).

Displaying other alarm codes

Pressing START button, all alarms in the appliance will be displayed.

The configuration errors E93 are displayed through the flashing of all LEDs and it is not possible to access the diagnostic system.

### 9.3 Cancelling the last alarm memorized

It is good practise to cancel the alarm code from memory:

- After reading the alarm, to check whether it is repeated during the diagnostics cycle.
- After effecting repairs to the appliance, to check whether it is repeated during testing.

1. Activate the diagnostic mode.
2. Turn the programme selector clockwise to the tenth position in conductimetric models and to the eighth position in vented models.
3. Push simultaneously the button (start/pause) and its nearest left button.
4. Hold down the buttons for about 5 seconds.
5. Once the alarm has been cancelled, E00 is displayed.

### 9.4 Notes concerning certain alarm codes

- Configuration alarm E93:  
When configuration alarms are displayed (when the appliance is switched on), the appliance is inoperative and all the LEDs light up: it is not possible to access diagnostics mode; the only possible operation is that of switching off the appliance (selector knob on position "0").
- Alarms EH1-EH2-EH3:  
In the event of problems with the power supply, the appliance remains in alarm mode until the voltage and frequency are restored to normal values or the appliance is switched off (selector knob on position "0"). Alarm family "H" is displayed and it is not possible to access diagnostic mode nor to use the "rapid alarm display" function: the complete alarm can be read only when the abnormal condition has terminated.

## 9.5 Table of alarms

Alarm	Description	Possible fault	Action/machine status
E00	No alarm.	---	---
E21	Canister fill pump triac faulty.	Wiring faulty. Electronic board faulty.	Cycle interrupted.
E22	Triac "sensing" circuit for the canister fill pump faulty	Electronic board faulty.	Cycle interrupted.
E31	Signal frequency of the sensor too high.	Electronic board faulty.	Alarm activated only during diagnostics.
E32	Signal frequency of the sensor too low.	Wiring faulty. Damaged brushes / faulty. Electronic board faulty.	Cycle interrupted.
E33	Appears in the displaying of the last alarm, if position 8 is NOT OK.	Wiring faulty. Damaged brushes / faulty. Electronic board faulty.	Alarm activated only during diagnostics.
E45	Door closure sensor.	Door interlock faulty. Wiring faulty. Electronic board faulty.	Cycle interrupted.
E57	Current absorption of the drum rotation motor out of range.	Motor faulty. Wiring faulty. Motor control main board faulty.	Cycle interrupted.
E58	Current absorption of drum rotation motor too high	Motor faulty. Wiring faulty. Motor control main board faulty.	Cycle interrupted
E59	Drum motor control board does not receive the correct signals from the main board	Motor faulty. Wiring faulty. Motor control board faulty.	Cycle interrupted.
E5H	Power supply of motor control board too low.	Wiring faulty. Motor control board faulty.	Cycle interrupted.
E5C	Power supply of motor control board too high.	Motor control board faulty.	Cycle interrupted.
E5E	Faulty communication between motor control board and main board.	Wiring faulty. Motor control board faulty. Main electronic board faulty	Cycle interrupted
E5F	Motor control board faulty.	Motor control board faulty.	Cycle interrupted
E61	Insufficient heating (maximum time exceeded)	Heater unit faulty. Wiring faulty. NTC sensor faulty/out of place. Electronic board faulty.	Cycle paused.
E62	Power relay to heater unit faulty	Heater unit faulty. Wiring faulty. Electronic board faulty.	Forced cooling. circuit
E63	Intervention of auto-reset thermostat on the heater unit.	Thermostat faulty. Heater unit faulty. Wiring faulty. Electronic board faulty.	Disconnects the power supply to the heater unit. If the problem does not re-occur, the alarm is memorized and the cycle continues. If the fault persists after several attempts to supply power, alarm E62 is generated.

E64	Heater thermostat.	Thermostat faulty. Wiring faulty. Electronic board faulty.	---
E65	Fan motor triac faulty.	Fan motor wiring disconnected. Motor faulty. Triac faulty.	---
E66	Fan motor thermal cut-out.	Fan motor wiring disconnected. Motor faulty. Triac faulty.	---
E67	Triac control faulty.	Fan motor wiring. Electronic board faulty.	
E71	NTC1 sensor faulty.	TC1 sensor faulty. Wiring faulty. Electronic board faulty.	Forced cooling circuit.
E72	NTC2 sensor faulty.	NTC2 sensor faulty. Wiring faulty. Electronic board faulty.	
E82	Selector in OFF position faulty.	Board wiring. Electronic board faulty.	
E83	Wrong selector positions	Board wiring Electronic board faulty	
E93	Error in the configuration of the appliance.	EEPROM configuration incorrect. Electronic board faulty.	Cycle interrupted.
E94	Error in the configuration of the drying cycle.	EEPROM configuration incorrect. Electronic board faulty.	Cycle interrupted.
E97	Incongruency between selector and cycles.	Error in the configuration.	Cycle interrupted.
EH1	Power frequency to appliance out of limits.	Problems with the power supply. Electronic board faulty.	Cycle interrupted. If a stable power supply is restored before the time-out has elapsed, the cycle resumes.
EH2	Voltage too high.	Problems with the power supply. Electronic board faulty.	Cycle interrupted.
EH3	Voltage too low.	Problems with the power supply. Electronic board faulty.	Cycle interrupted. If a stable power supply is restored before the time-out has elapsed, the cycle resumes.



# 10 NO ACCESS TO DIAGNOSTICS PROGRAMME

## 10.1 No LEDs on the display board light.

Power cable and connection OK ?	NO		Replace or repair the power cable and perform the diagnostics programme
YES			
Does the suppressor (incorporated in the main terminal block) function correctly?	NO		Replace the terminal block + suppressor and perform the diagnostics programme
YES			
Remove the connector from the main terminal block and connector J8 of the electronic board. Measure the continuity of the wiring across terminals and L. Is the circuit closed?	NO		Replace or repair the wiring and perform the diagnostics programme
YES			
Measure the continuity of the wiring across terminals and N. Is the circuit closed?	N O	Remove the connector from the heater unit and measure the closure of the thermostat. Is the circuit across terminals 3 - 5 of the heater unit closed?	N O  Identify the cause of the interruption in the operation of the fan causing the thermostat to intervene, and eliminate the cause. Replace the heater unit and perform the diagnostics cycle
YES		YES	
		Replace/repair the wiring and perform the diagnostics cycle	
Does the programme selector function correctly mechanically ?	NO		Replace/repair knob or spindle

YES

Does the wiring that connect the electronic board with the control/display board function correctly? (insert and remove the connector)

Replace main board and perform the diagnostics cycle. Does the appliance function correctly?

YES

Appliance functions correctly

## 10.2 Some of the LEDs on the display board light

Do the power cable and the connection action correctly ?

NO

Replace/repair power cable and perform the diagnostics cycle

YES

Does the suppressor (incorporated in the main terminal block) function correctly?

NO

Replace the terminal block + suppressor and perform the diagnostics programme

YES

Appliance functions correctly

### WARNING

It is not possible to access the diagnostics system if the main electronic board has not been configured correctly: configuration errors (E93) are indicated by the flashing of all the LEDs

## 11 ACCESSIBILITY TO COMPONENTS

### 11.1 Door

To remove the door, remove the screws which secure it to the hinge.

Fluff filter

Open the filter support pushing the relative button, lift out and clean it at the end of each cycle

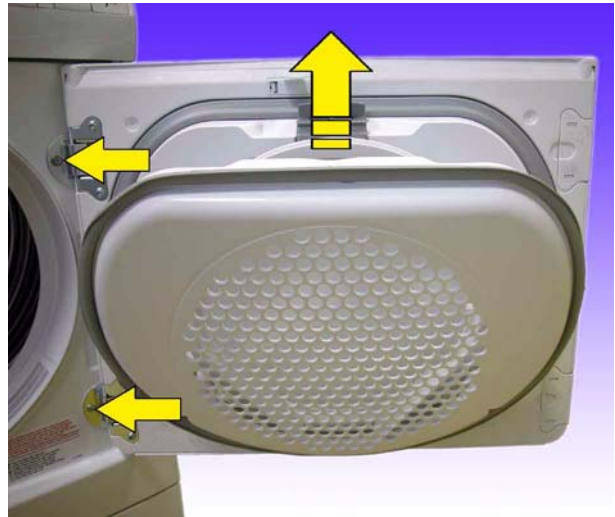

### 11.2 Lower fluff filter

Remove by lifting from its seat and clean it at the end of each cycle.



### 11.3 Door interlock

Remove the screw which fits it, lower it slightly spinning it forward.

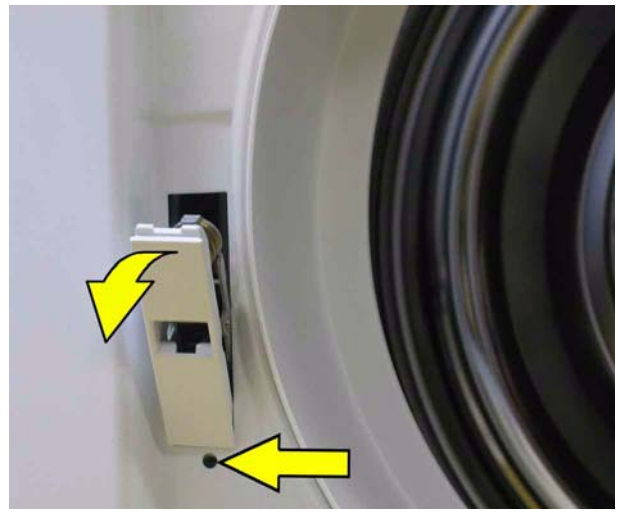

### 11.4 Microswitch door

Remove the screw extract it slightly and move it towards left till to reach the connector. Detach the connector and fix it with some adhesive tape on the front side so as to avoid losing it inside the appliance.

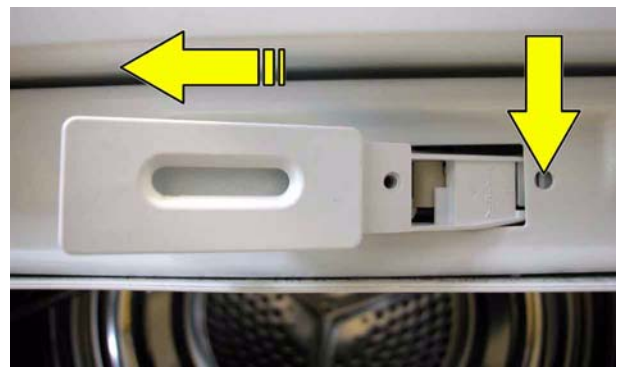

### 11.5 Door interlock catch and micro door catch

To remove the micro door catch and the door interlock catch push with a screwdriver on the hook and rotate them as indicated by the arrows.



## 11.6 Drum light

The bulb can be replaced from inside the drum.

Remove the two screws which secure the bulb cover  
Unscrew the bulb from the bulb-holder.  
When replacing the cover, ensure that the sealing  
ring is correctly positioned in its seat.



## 11.7 Canister

Extract the canister paying attention not to drop the  
water remained inside on electrical parts.



## 11.8 Work top

To remove the work top, first remove the two screws which secure the top to the rear edge of the appliance and slide it out towards the rear panel.



## 11.9 Control panel support and control panel assembly

Remove the canister.

Remove the screws which secure the control panel to the canister support.



Remove the screws which secure the control panel crossmember.

Turn forwards the crossmember and the control panel.

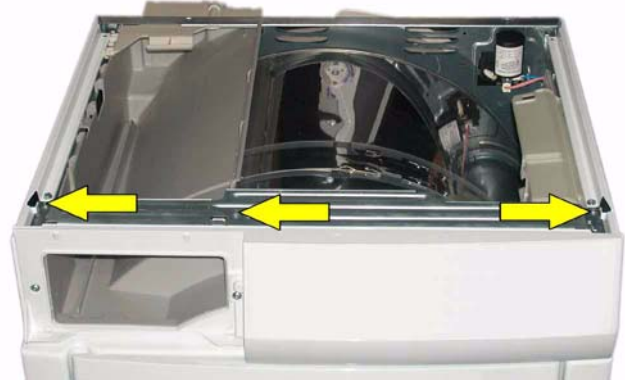



## 11.10 Main electronic board

### Removing the electronic board

To remove the electronic board:

Remove the 8 screws which secure the electronic board to the control panel.

Push moderately on the fixing clips and remove the board.

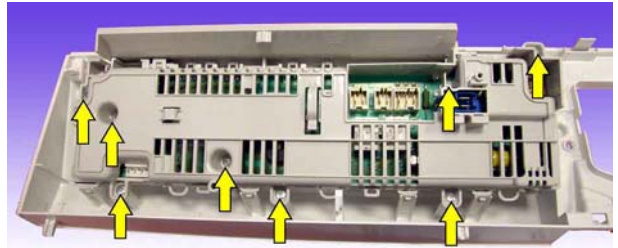

### Removing the selector pin

After removing the main board it is possible to remove the selector pin positioning it to OFF and pulling it forward.

#### ATTENTION

Should the pin not come out, check if it is in OFF position.

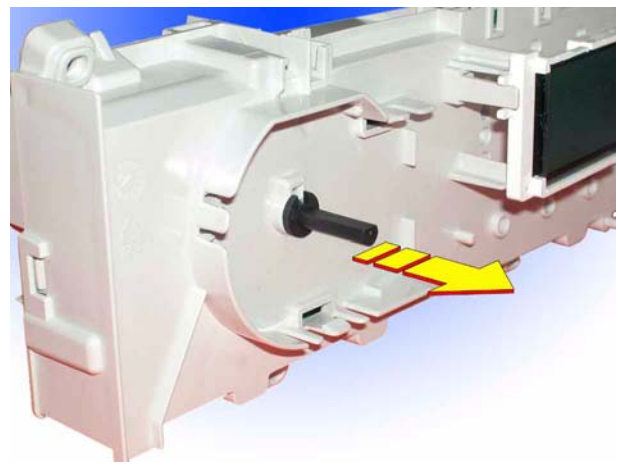

### Removing the selector knob

After removing the main board it is possible to remove the selector knob.

Push the long side parts toward the centre and simultaneously push the knob externally.

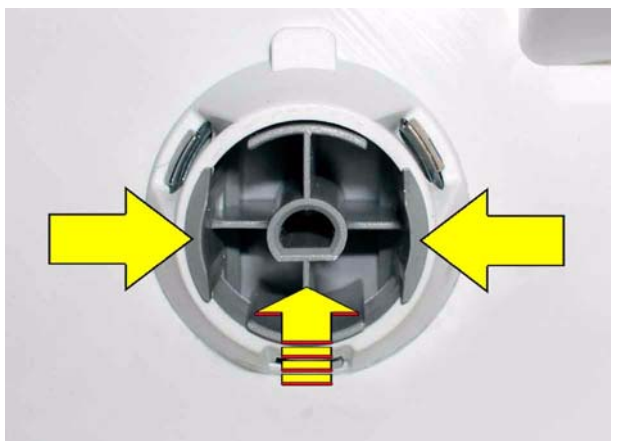

### Button springing system

The button springing system remains hooked to the main board support by means of the side clips.

## 11.11 Motor control board

Remove the work top (as previously described).

Remove the screw which secures the right side panel (it is not necessary to remove the panel).

Pull inside the appliance the fixing clip, turn the protection upwards and remove it.

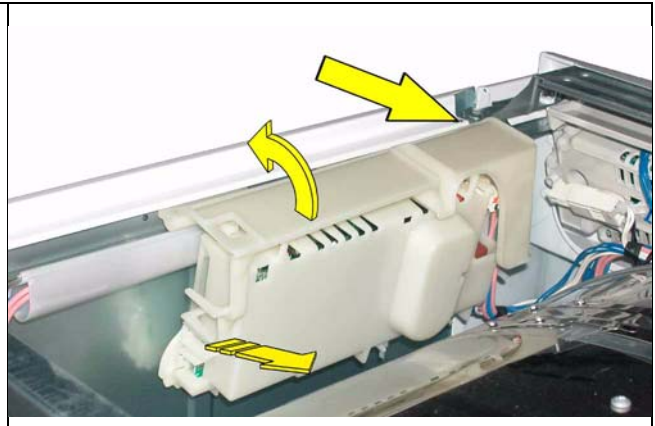

Remove the fixing screw.

Move the board support to the left, rotate slightly and remove it.

Detach the cables.

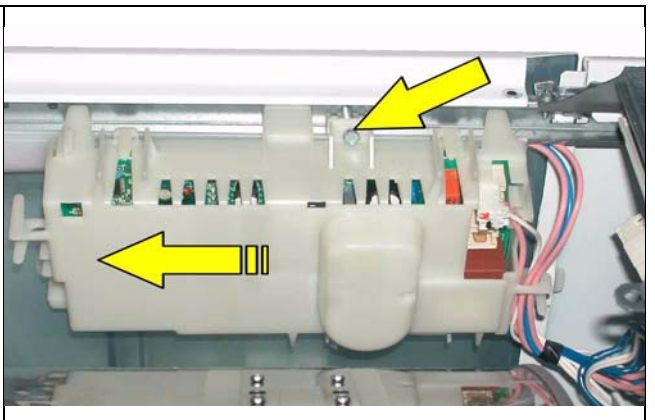

## 11.12 Rear panel cover

Remove the 9 screws (A) which secure the plastic rear panel cover in the external part.

Remove the 3 screws (B) which secure the rear panel cover in the internal part.

Remove the rear panel cover and the insulating carpet.

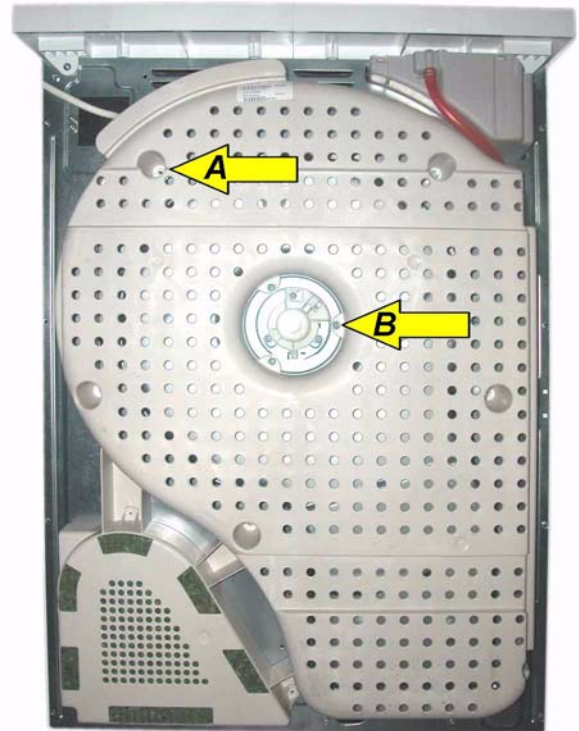

Remove all the perimetral screws which secure the rear panel cover and remove it.

While removing the rear panel cover, it is necessary to press slightly so that the gasket detaches from the rear panel.



### 11.13 Heater unit

Remove the left side panel (viewing the appliance from the front).

Unscrew the screw that secures the side panel to the crossbar (remove first the canister).

When replacing the side panel, replace the screws in their original positions, otherwise the continuity of the earth circuit will be broken.



Remove the screws which secure the side panel to the rear panel, lift and remove it.



The terminal block for the heater unit is located inside the microswitch support, and secured in position by an anchor tab.

Insert a screwdriver, release the anchor tab and remove the terminal block. Remove the wire ties that secure the wiring to the base and remove the wiring.

Remove the two screws which secure the heater unit to the rear panel, paying attention that the right screw of the heater unit fixes a deflector.

When replacing the heater unit, be sure to re-position the wiring in its original position

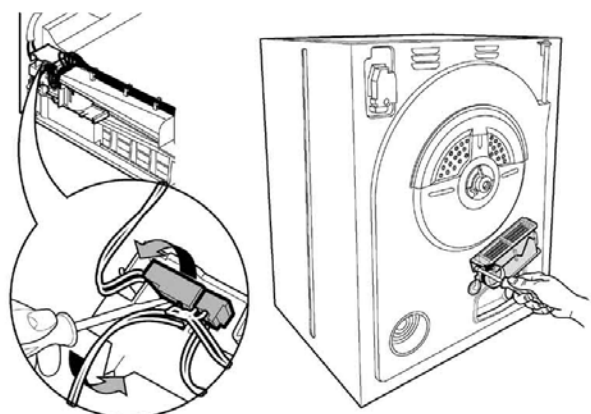

### 11.14 Lower brush conductimetric sensor

To access the lower brush of the conductimetric sensor detach the connector (faston). Push downward the two fixing clips and simultaneously extract the brush assembly.

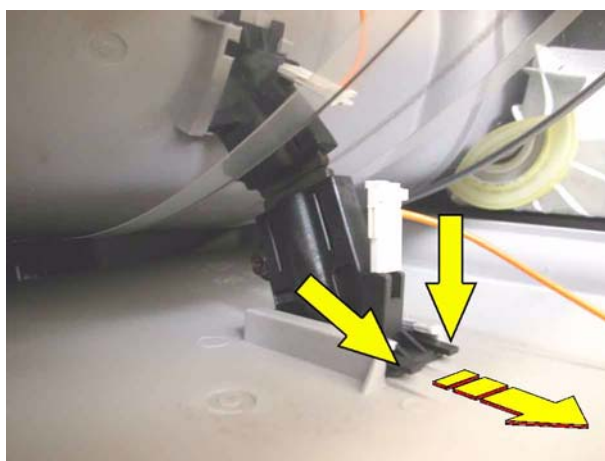

### 11.15 Rear brush

Remove the screw which secures the drum spindle cover.

Rotate the drum spindle cover until it is released from the anchor in the lower section.

Inside the protection there is the brush.

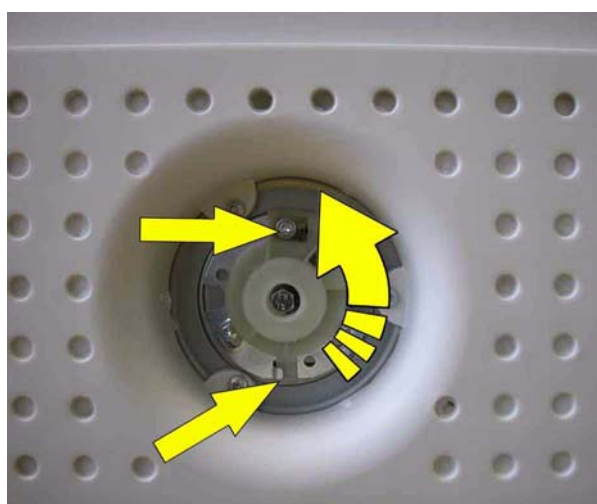

## 11.16 Floating microswitch

Remove the work top (see above).

Remove the screws which secure the side panel and remove it (see above).

In the rear section of the base, the sump contains the pump, the floating microswitch and the float.

Remove the two tubes from their couplings (the red tube which fills the canister, and the transparent tube through which water overflow is ducted back to the sump when the canister is full).

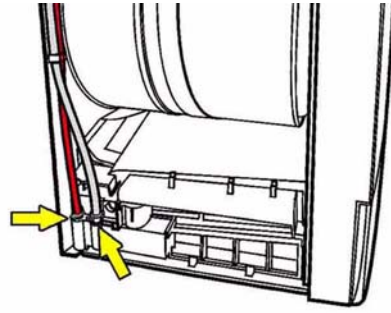

Remove the screw (1) which secures the microswitch support and insert a screwdriver into the two anchor tabs which secure it to the sump.

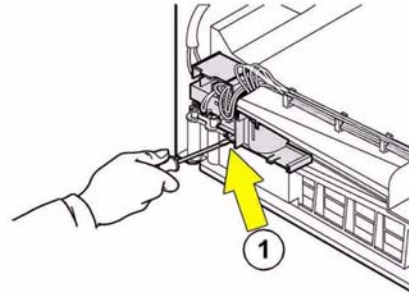

Lift both parts simultaneously and slide the microswitch support outwards.

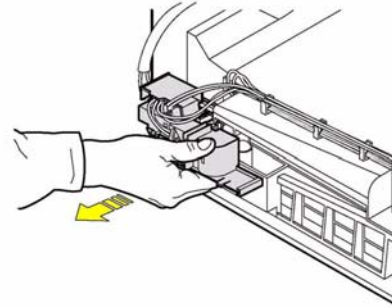

Turn the support upside-down to access the floating microswitch.

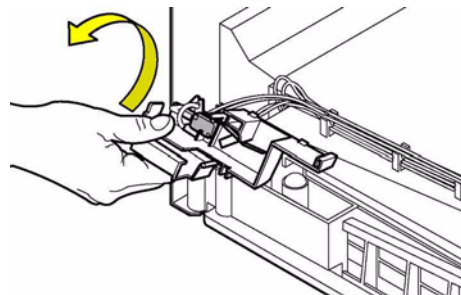

## 11.17 Float

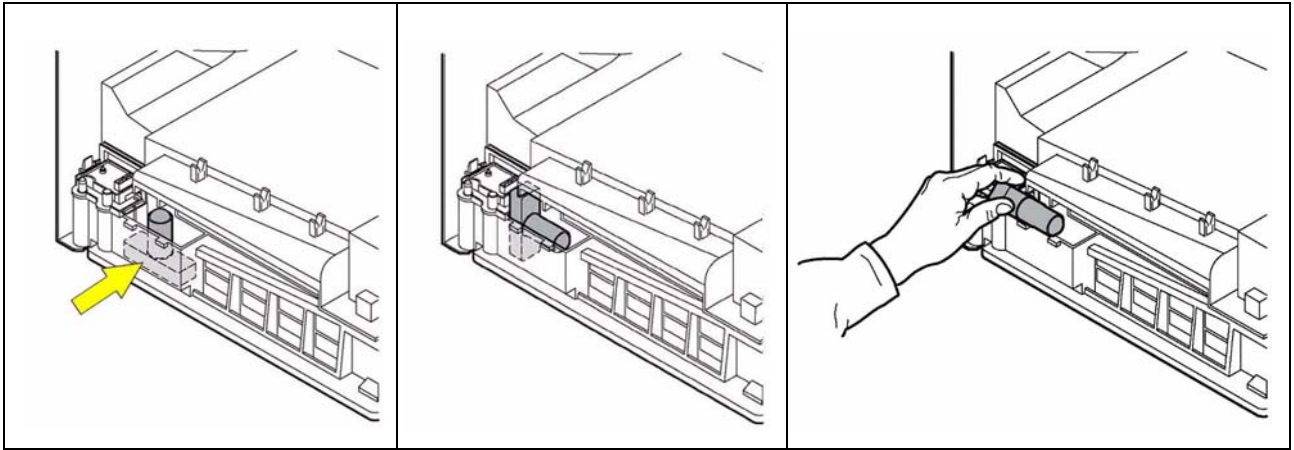

The float is located inside the sump.

To remove the float, turn it 90° clockwise as shown in the figure.

Lift and rotate it outwards, and remove it.

To re-fit the float, repeat this procedure in reverse sequence.

## 11.18 Pump

The pump, which ducts the water from the sump to the canister is located next to the sump containing the float.

To remove the pump from its seat, it is necessary to disconnect the wiring connectors, remove the screw and release the anchor tab (shown by the arrow) which secures the pump to the sump; remove the pump.

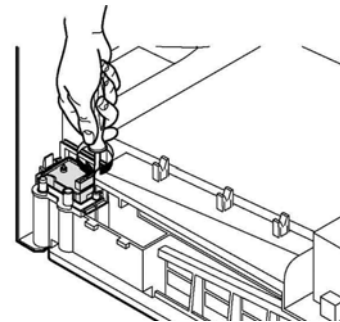

When re-assembling the pump, the float and the canister microswitch, repeat the procedure described above in reverse sequence. When replacing the microswitch support, insert a screwdriver into the gap (shown by the arrow) in order to lift the microswitch lever and place it against the top of the float. If this procedure is not performed, the microswitch lever will remain alongside the float and become bent. In this case, the two components will not function correctly.

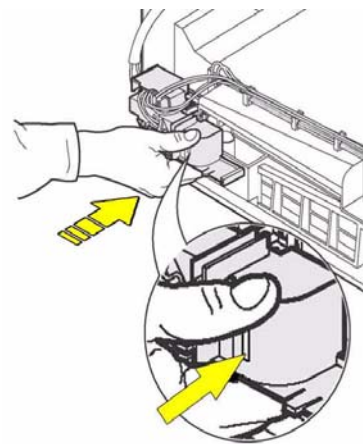

## 11.19 NTC sensor

Remove the work top (as previously described).

Remove the screw which secures the right-hand side panel to the crossmember and remove the panel.

While reassembling the side panel, position the screws in the same position, otherwise the ground continuity is not ensured.

Remove the screws which secure the side panel to the rear panel.

Lift and extract it.



Extract the sensor from the gasket and detach the connector.





## 11.20 Front air duct cover (hot air circulation)

Extract the motor wiring from the hook which secures it on the scroll cover.

Remove the three screws which secure the scroll cover to the base and remove it.

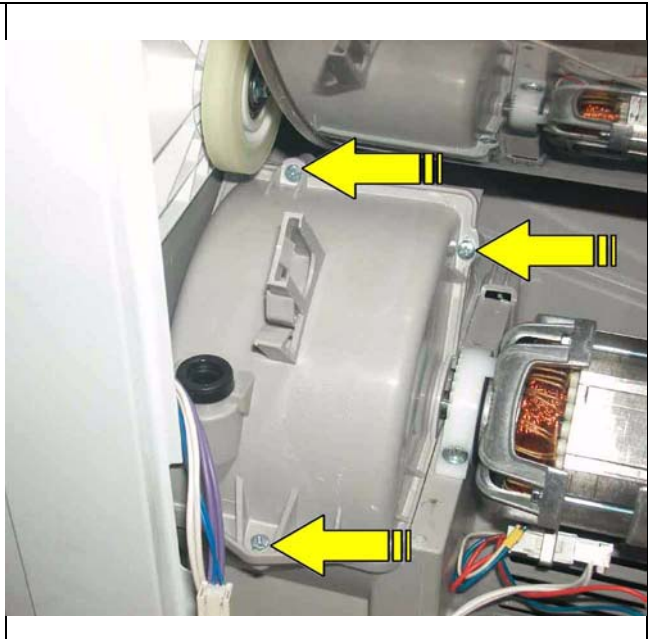

## 11.21 Rear air duct cover (cold air circulation)

Remove the screw.

Release the scroll cover from the three anchor tabs (two laterals and one lower) which secure it to the base and extract it.

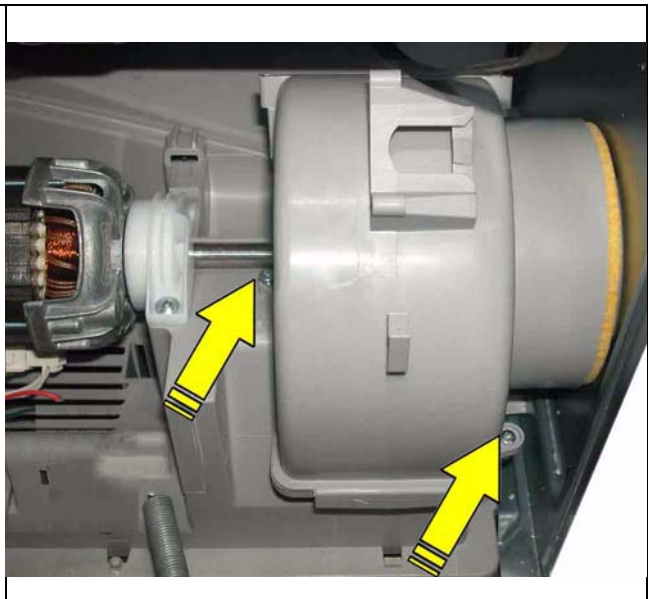

## 11.22 Drum rotation motor

After removing the covers, it is possible to access the drum motor.

Remove the belt tensioner spring.

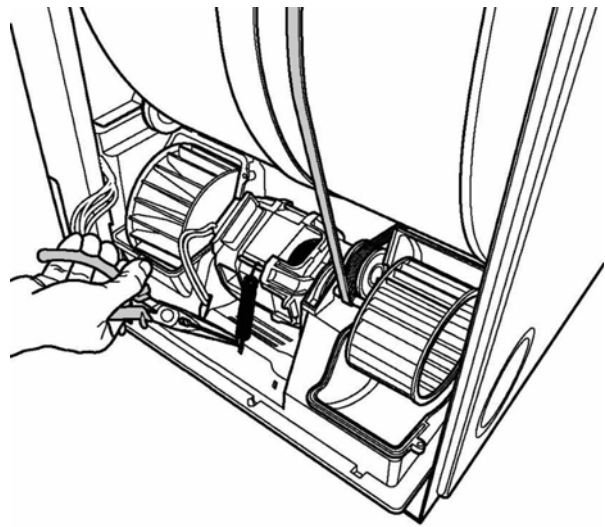

Remove the screws which secure the front motor support brackets, rotate upwards and remove.

Rotate the whole motor unit (consists of: motor and the two fans) inside the appliance, lift and extract it after sliding the belt out from the fan.

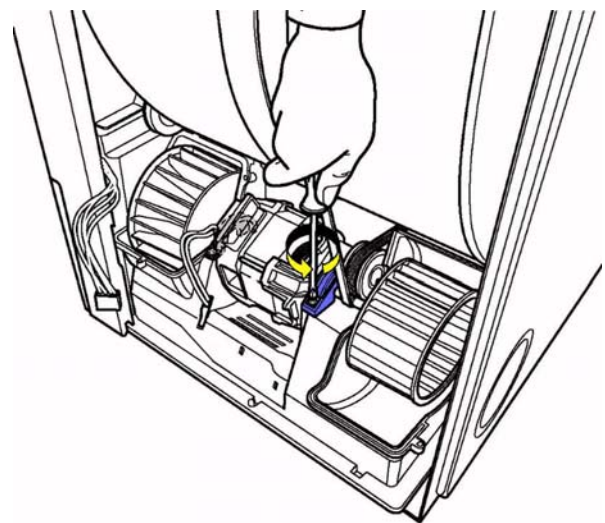

Replacing the belt tensioner roller / drive belt

1. Spacer.
2. Belt-tensioner roller with incorporated spacer.
3. Elastic ring.
4. Belt in central position.
5. Leave two grooves free on each side of the pulley.

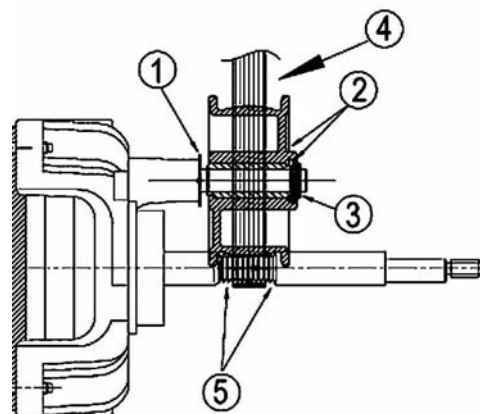

### 11.23 Capacitor (heat exchanger)

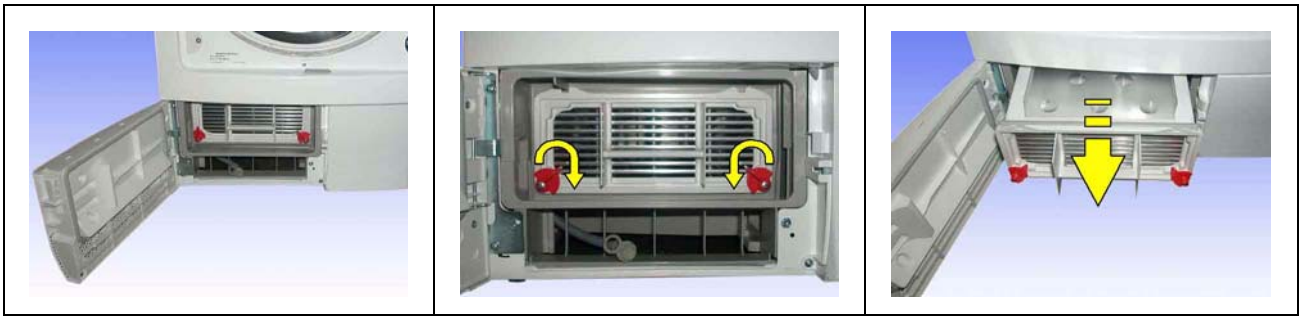

Open the flat door, turn the two red retainers downwards and extract the heat exchanger pulling it outside.

### 11.24 Front flap

Remove the screws which secure it to the front panel. To remove the gasket, extract it from its seat. To access to the opening button, remove the fixing screws inside the flap and release the upper three anchor tabs

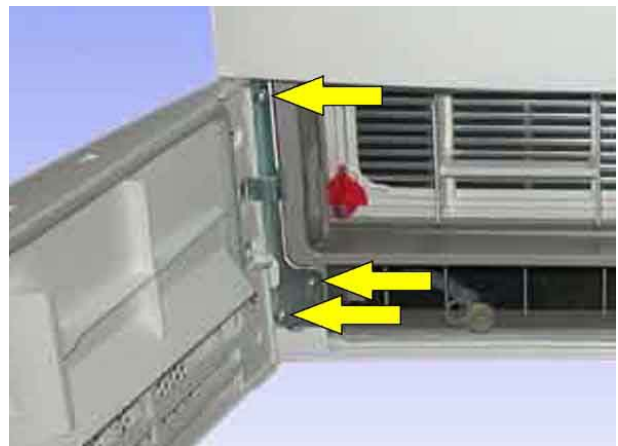

When re-fitting the flap in its housing, first ensure that the three anchor tabs are correctly positioned, and only then tighten the screws.

Check that the flap latch, when closed, actions the lever of the microbox, otherwise the dryer will not be powered.

### 11.25 Rear panel

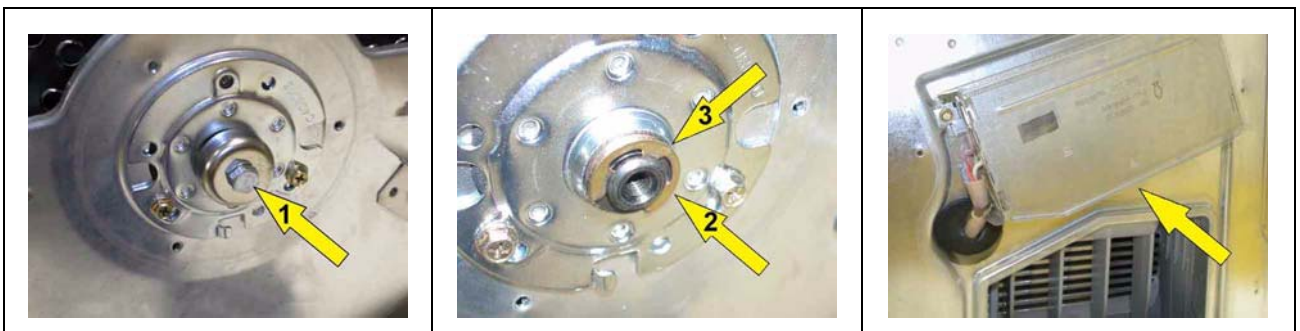

Remove the work top.

Unscrew the screw which secures the canister support.

Remove the left-hand and right-hand side panels.

Remove the back air cover.

Remove the rear brush.

Unscrew the screw which secures the bush (1).

Remove the Benzing ring (2) and, if featured, the spacing washer (3).

Disconnect the terminal block from the heater unit.

Disconnect connectors on the main terminal block.

Unscrew the screws which secure the rear panel to the crossbars and to the base.

A screw beneath the heater unit secures the rear panel to the base.

## 11.26 Drive belt

Remove the work top.

Remove the side panels.

Remove the belt tensioner spring

Cut the damaged belt

Remove the rear panel.

Cut the rear scroll cover (it is not necessary to remove the motor).

Remount the belt following the phases in figure.

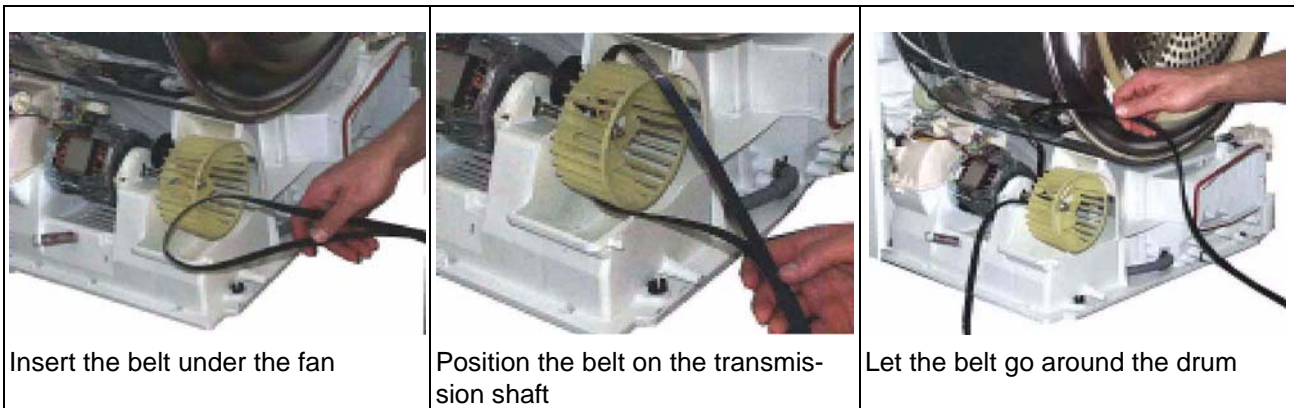

## 11.27 Duct

Remove the work top.

Remove the rear panel.

Remove the drum.

Unscrew the screws which secure it to the hinges and hinge hole masking plates.

Extract the duct.

## 11.28 Duct rollers

Remove the work top.  
Remove the rear panel.  
Remove the drum.  
Remove the screws (a) and (b) which secure the rollers to the duct.

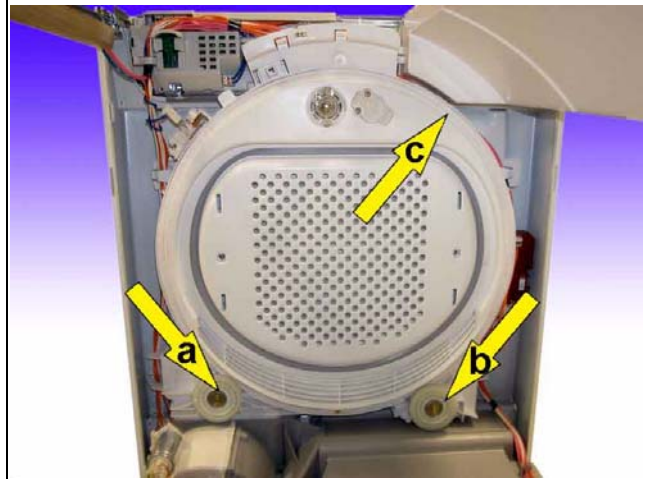

## 11.29 Front and rear seals

Slide out the front seal (C) from its seat.

The rear seal can be simply pulled away from the ring fitted to the rear panel.

Notes for replacement of the rear drum seal

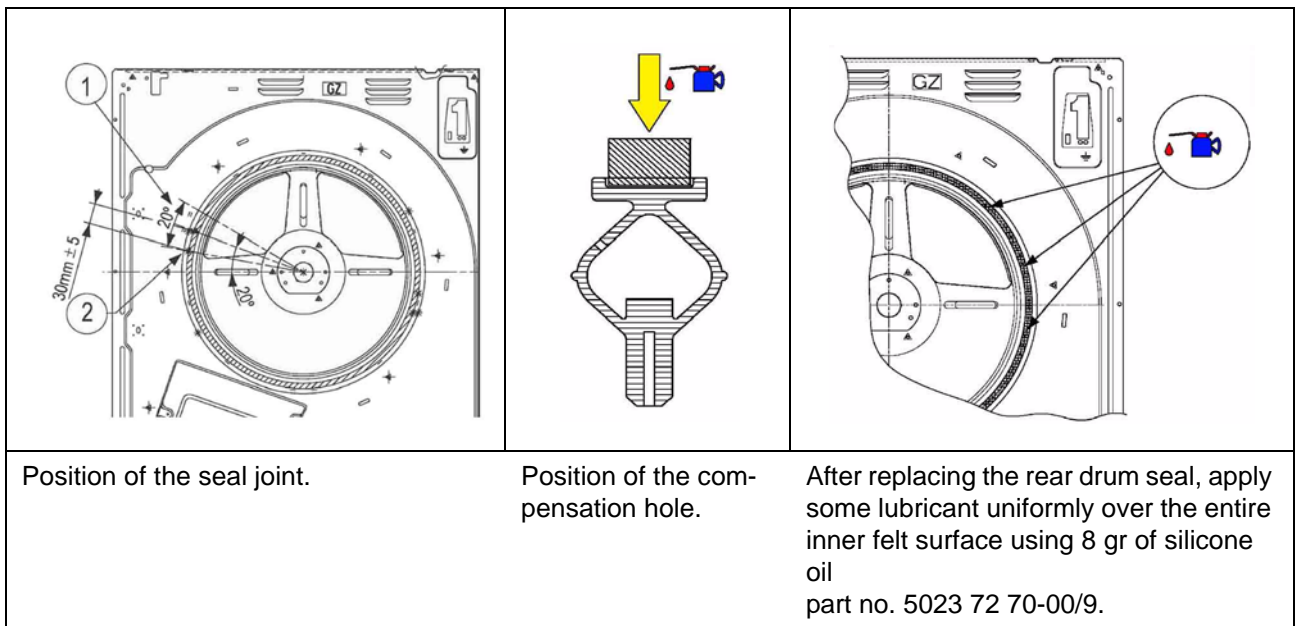

## 12 Reversibility of the door

- Open the door
- Remove the door unscrewing the 2 screws which secure the hinges (A) to the appliance.
- Remove the masking plates (B) and (C) pushing them with a subtile screwdriver.
- Remove the door interlock catch (D) pushing it with a screwdriver and reuse it on the opposite side turned by 180° (upside-down).
- Remove the hinges (A) and reuse them on the opposite side turned by 180°
- Remount the masking plates (B) and (C) on the opposite side turned by 180° so as to cover the remaining holes.

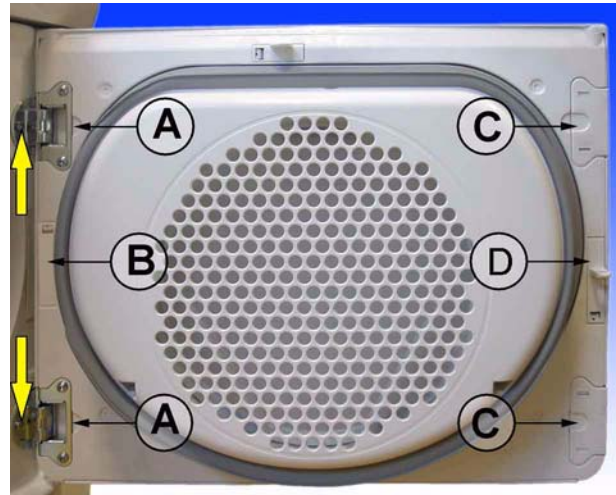

- Remove the 2 masking plates (E), turned them by 180° and remount them on the opposite side.

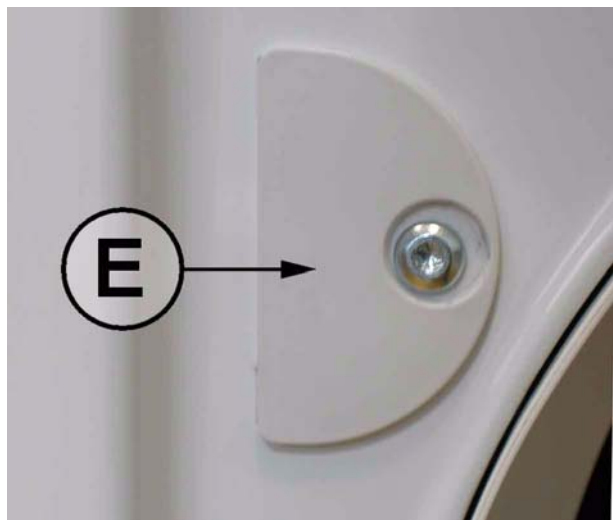

- Remove the door latch (F), push it downwards and remove it turning it down.
- Push the anchor tab of the cover (G) and simultaneously push it downwards.
- Position the door (F) on the opposite side of the appliance and fix it with the screw previously removed.
- Position the cover (F) on the opposite side of the appliance paying attention that the anchor tab enters the hole.
- Remount the door with the hinges on the opposite side, fix the screws and check the correct operation.

