

© ELECTROLUX HOME PRODUCTS
Customer Care - EMEA
Training and Operations Support
Technical Support

Publication no.

599 70 56-70

EN

Edition: 02/2013 - Rev. 03

**Washing machines
&
Washer-dryers**

**Guide to diagnostics
of electronic controls**

ENV06

EWM2100

Contents

1	INTRODUCTION.....	5
1.1	Purpose of this manual	5
1.2	Procedure	5
2	WM APPLIANCES CONTROL PANELS	6
3	WD APPLIANCES CONTROL PANELS	8
4	DIAGNOSTIC SYSTEM.....	10
4.1	ACCESS TO THE DIAGNOSTIC CYCLE	10
4.2	Exiting diagnostics mode	10
4.3	PHASES OF THE DIAGNOSTIC CYCLE	11
5	ALARMS	13
5.1	Displaying the alarms to the user	13
5.2	Reading the alarm codes.....	14
5.2.1	Alarm displaying.....	14
5.2.2	Examples of alarm display	15
5.2.3	Operation of alarms during diagnostics	15
5.3	Rapid reading of alarm codes.....	16
5.4	Cancelling the last alarm	16
5.5	TABLE OF ALARMS.....	17
5.6	Notes concerning certain alarm codes	21
6	THE DIAGNOSTIC PROGRAMME CANNOT BE ACCESSED	22
6.1.1	All LEDs on the circuit are board switched off	22
6.1.2	Some of the LEDs of the circuit board light.....	22
7	TROUBLESHOOTING ACCORDING TO ALARM CODES	23
	E11: Difficulty in filling water during washing phase	23
	E12: Difficulty in filling water during drying phase.....	25
	E13: Water leakage.....	26
	E21: Difficulty in draining.....	28
	E22: Difficulty in draining water during drying phase	30
	E23: Malfunction of the component (triac) that controls the drain pump	32
	E24: "Sensing" circuit of the component (triac) that controls the drain pump faulty	33
	E35: Water level too high	35
	E38: Pressure chamber blocked	36
	E3A: Problems with "Sensing" circuit of the heating element relay	37
	E41: Door open (3-contact device)	38
	E41: Door open (4-contact device)	40
	E42: Problems with door aperture (3-contact device).....	42
	E42: Problems with door aperture (4- contact device).....	44
	E44: Door closure "sensing" circuit faulty.....	48
	E45: Problems with the "sensing" circuit of the triac that actions the door interlock.....	48
	E51: Motor power triac short-circuited	49
	E52: No signal from the motor tachometric generator (<i>first part</i>).....	50
	E52: No signal from the motor tachometric generator (<i>second part</i>).....	52
	E53: Problems with the "Sensing" circuit of the triac which powers the motor	54
	E54: Motor relay contacts sticking.....	55
	E61: Insufficient heating during washing.....	56
	E62: Overheating during washing (version WM).....	57
	E62: Overheating during washing (version WD).....	58
	E66: The contacts of the heating element power relay are always closed (version WM).....	59
	E66: The contacts of the heating element power relay are always closed (version WD)	60
	E68: Washing heating element leaks current (version WM)	61
	E68: Washing heating element interrupted (version WD)	62
	E69: Washing heating element interrupted (version WM)	63
	E69: Washing heating element interrupted (version WD)	64
	E71: NTC washing sensor faulty	65
	E72: Drying NTC sensor on condenser faulty.....	66
	E73: NTC sensor on drying duct faulty	67
	E74: NTC sensor wrongly positioned.....	68
	E82: Error in reading the RESET/OFF position of the programme selector	69
	E83: Error in reading the programme selector code	70
	E91: Communication error between user interface and main board.....	71
	E92: Protocol incongruence	71
	E93: Appliance configuration error	71

E94: Washing cycle configuration error	71
E95: Communication failed between EEprom and Microprocessor.....	71
E97: Incongruence between version of the control selector and configuration data	71
EA1: Drum positioning system (DSP) faulty (<i>top-loaders</i>).....	72
EA6: Drum flap faulty (<i>top-loaders</i>).....	73
EH1: Incorrect mains frequency	74
EH2: Mains voltage too high	74
EH3: Mains voltage too low	74
EF1: Drain hose blocked/throttled/too high; drain filter dirty/blocked.....	75
EF2: Overdosing of detergent; drain hose blocked/throttled; drain filter dirty/blocked	75
EF3: Intervention of Aqua Control device	75
EF4: Low water fill pressure and solenoid open	75
EF5: Load too unbalanced, skipping of spin phases	75
EF6: Appliance reset.....	75
EC1: Water fill solenoids blocked.....	76
ED1: Communication problems between main circuit board and WD board.....	77
ED2: Drying heating element 1 faulty.....	78
ED3: Drying heating element 2 faulty.....	81
ED4: Drying relays faulty.....	82
ED6: Communication failure between main circuit board and Satellite board (INPUT styling)	84
8 BASIC CIRCUIT DIAGRAM WM	85
8.1 Key to circuit diagram WM.....	86
9 BASIC CIRCUIT DIAGRAM WM WITH AQUA CONTROL	87
9.1 Key to circuit diagram WM with Aqua Control	88
10 BASIC CIRCUIT DIAGRAM WD	89
10.1 Key to circuit diagram WD.....	90
11 BASIC CIRCUIT DIAGRAM WD WITH AQUA CONTROL.....	91
11.1 Key to circuit diagram WD with aqua control	92
12 CONNECTORS ON CIRCUIT BOARD WM/WD	93
13 BURNING ON THE CIRCUIT BOARD EWM2100 WM/WD	94
14 APPENDIX	95

1 INTRODUCTION

1.1 Purpose of this manual

The purpose of this Service Manual is to provide a simple and clear description of the procedure to be followed by service engineers when confronted by problems identified by the various alarm codes generated by appliances with the EWM2100 electronic control system.

Depending on the configuration of the appliance, the alarm codes may be displayed partially or completely to the user (the alarm codes are generally displayed partially). The diagnostic system can be used by service engineers for the following purposes:







- ◆ To read the alarms
- ◆ To cancel alarm conditions stored in memory
- ◆ To test the operation of the appliance

1.2 Procedure

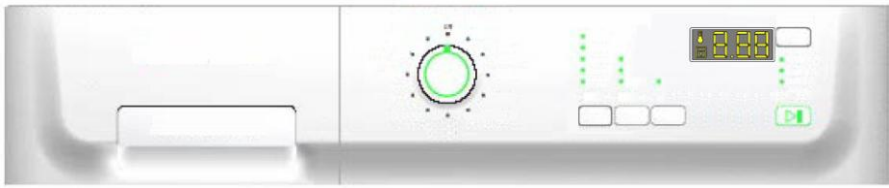

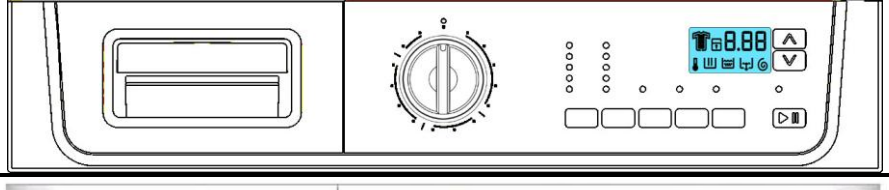

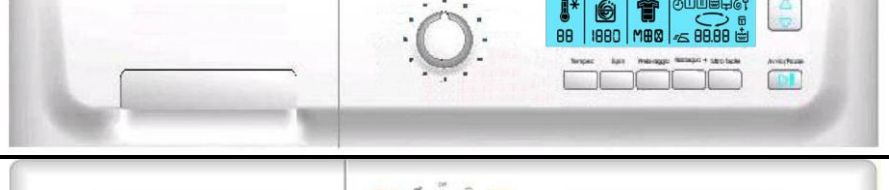
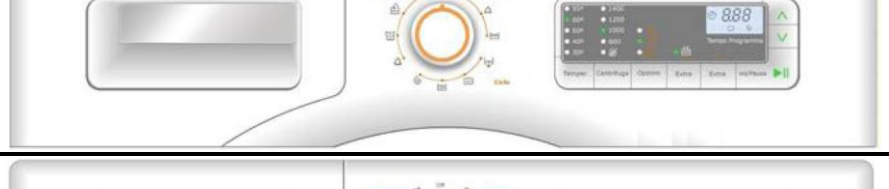
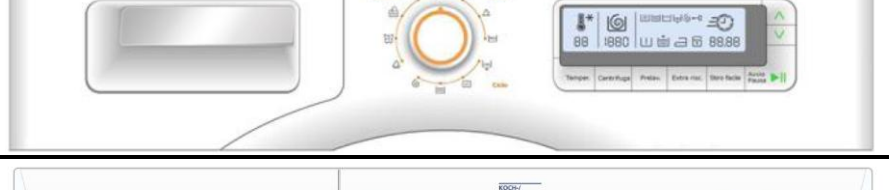

1. Identify the type of control system (**page 6/9**) and access the diagnostic cycle (**See page 10**).
2. Read the alarm code stored in memory (**page 14**) and refer to the instructions for the corresponding alarm code, **page 17÷20**.
3. Cancel the alarm stored in memory (**page 16**).
4. If access to the diagnostic cycle is not possible, refer to the section “Access to diagnostic system impossible” (**page 22**).
5. If the main PCB is replaced, check that there are no burned parts (**see page 94**).
6. After any repair, always check the operation of the appliance using the diagnostic cycle (**page 10**).
7. Cancel any alarms stored in memory during the diagnostic procedure (**page 16**).

2 WM APPLIANCES CONTROL PANELS





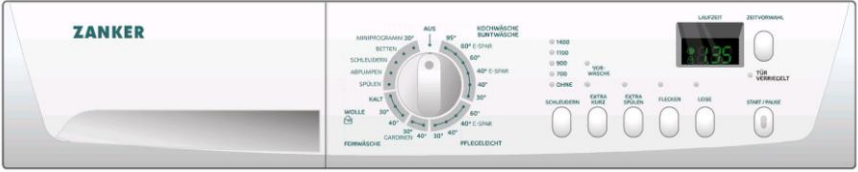

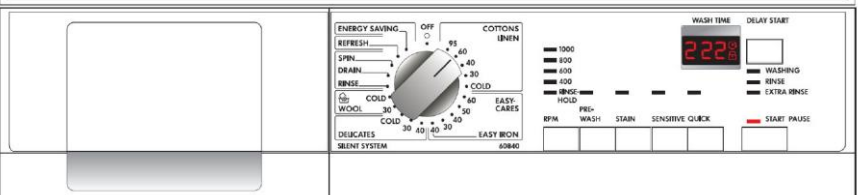
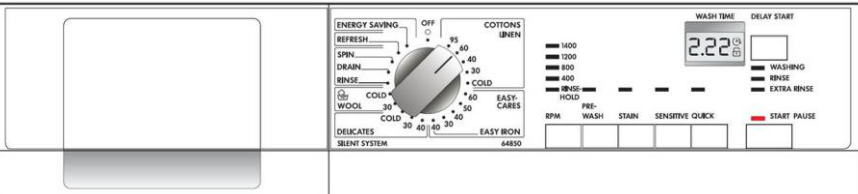
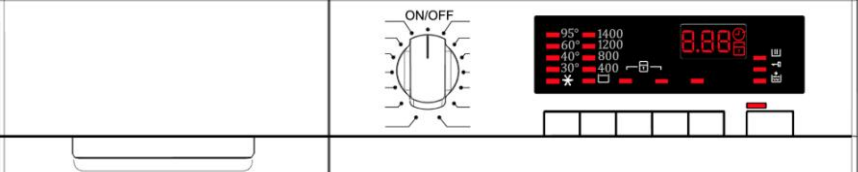

These are the stylings available at the time of printing of this Service Manual. Others may be developed in future.

ELECTROLUX	TC4	
	TC3 TIME MANAGER	
	TC3 PROPORTIONAL	
	TC3 TIME MANAGER	
	TC2 TIME MANAGER	
	TC2 PROPORTIONAL	
	TC3 ICON	
	TC2 ICON	
SMART A	A3 AF3-A4.2	

Continued

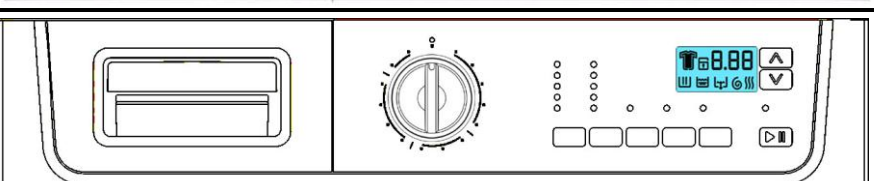
SMART C	C3 CF3	
INPUT	CI2	
	AI3&ZI3	
SMART Z	Z3	
SMART K	K3	
	K2	
AEG	6 Series SPECIAL	
	6 Series	
	6 Series	

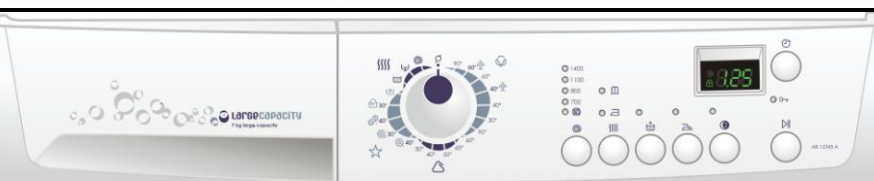
3 WD APPLIANCES CONTROL PANELS

ELECTROLUX	TC4	
	TC3 PROPORTIONAL	
	TC3 TIME MANAGER	
	TC2 TIME MANAGER	
	TC3 TIME MANAGER	
SMART C	C3 CF3	
SMART Z	Z3	
SMART K	K3	

Continued

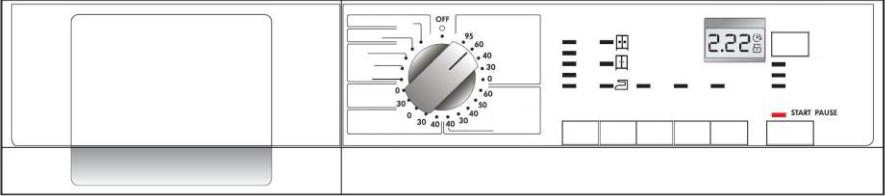
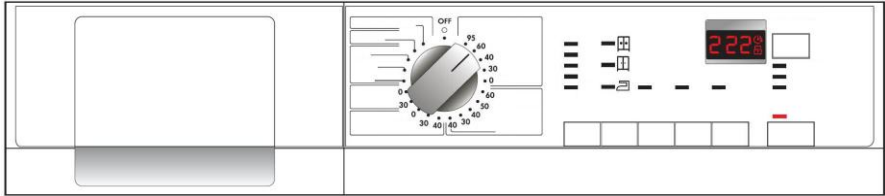
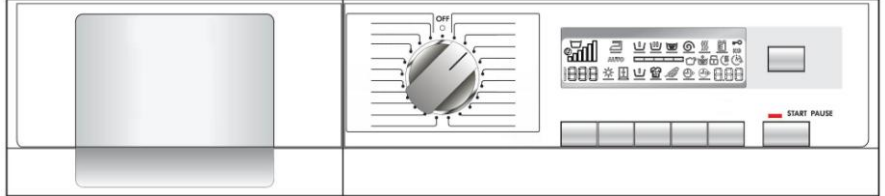
AEG	6 Series	
	6 Series SPECIAL	
	7 Series	

4 DIAGNOSTIC SYSTEM

4.1 ACCESS TO THE DIAGNOSTIC CYCLE

All versions

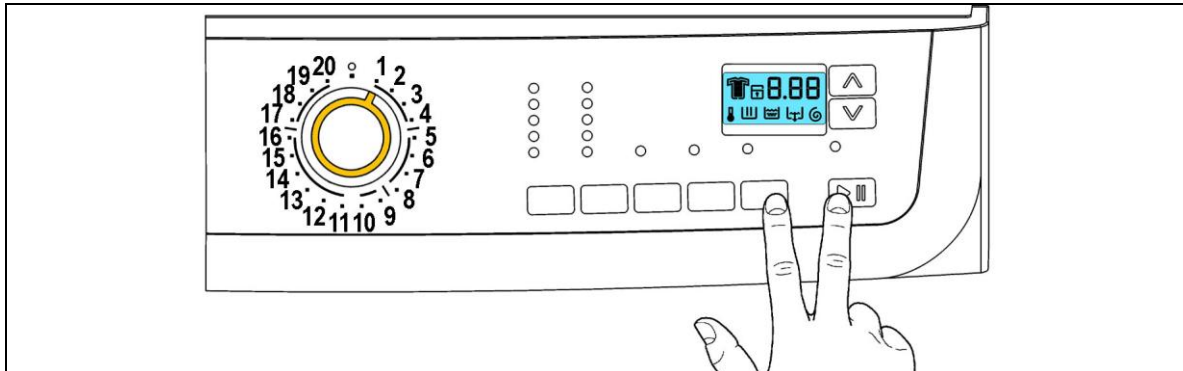

1. Switch off the appliance.
2. Press and hold down the **START/PAUSE** button and the nearest **OPTION** button simultaneously (as represented in figure).
3. Holding down both buttons, switch the appliance on by turning the programme selector **one position clockwise**.
4. Continue to hold down the buttons until the LEDs begin to flash (at least 2 seconds).

In the first position, the cycle tests the operation of the buttons and the relative LEDs. If the selector is turned **clockwise**, the cycle performs the diagnostics for the various components and reads the alarm codes.

INPUT Version

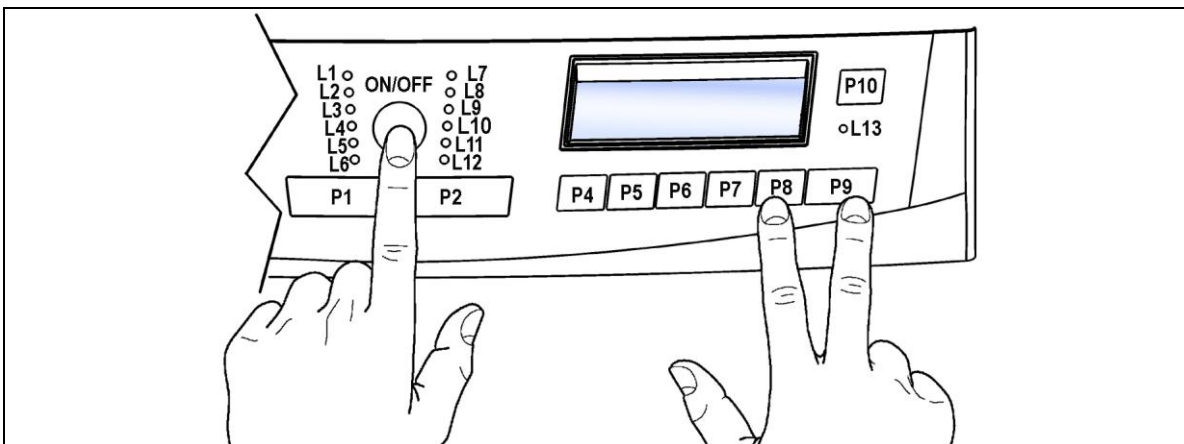

5. Switch off the appliance.
6. Press and hold down **START/PAUSE** button and the nearest **option** button (as represented in figure).
1. Holding down both buttons, switch the appliance on pushing button **ON/OFF**.
2. The test of the display board starts immediately.

Pushing sequentially button P1 positions from 2 to 10 are analysed in an increasing way, on the contrary push button P2.



Each position is confirmed by the switching on of the corresponding LED.

4.2 Exiting diagnostics mode

→ To exit the diagnostics cycle, switch the appliance off, then on, and then off again.

4.3 PHASES OF THE DIAGNOSTIC CYCLE

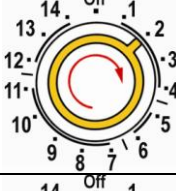
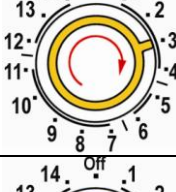
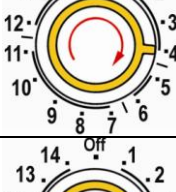
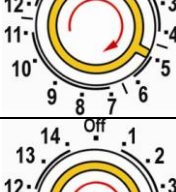
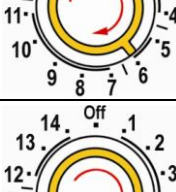
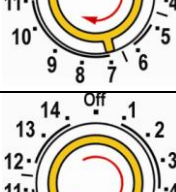
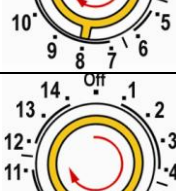
Irrespective of the type of PCB and the configuration of the programme selector it is possible, after entering diagnostic mode, turning the programme selector **clockwise or pushing the buttons P1 or P2** (INPUT version), to perform diagnostics on the operation of the various components and to read the alarms. All the alarms are enabled during the diagnostic cycle.

Selector position	Components actioned	Operating conditions	Function checked	LCD
1 	<ul style="list-style-type: none"> - All the LEDs and symbols light in sequence. - When a button is pressed, the corresponding LED or symbol light. 	Always activated	Operation of the user interface	All symbols are activated in sequence, the backlight lights up and then switches off.
2 	<ul style="list-style-type: none"> - Door interlock - Wash solenoid 	<ul style="list-style-type: none"> Door locked Water level below anti-flooding level Maximum time 5 minutes 	Water ducted through washing compartment	Displays the water level in tub
3 	<ul style="list-style-type: none"> - Door interlock - Pre-wash solenoid 	<ul style="list-style-type: none"> Door locked Water level below anti-flooding level Maximum time 5 minutes 	Water ducted through pre-wash compartment (bleach)	Displays the water level in tub
4 	<ul style="list-style-type: none"> - Door interlock - Pre-wash and wash solenoids 	<ul style="list-style-type: none"> Door locked Water level below anti-flooding level Maximum time 5 minutes 	Water ducted through conditioner compartment	Displays the water level in tub
5 	<ul style="list-style-type: none"> - Door interlock - Hot water solenoid or bleach/stains solenoid (on certain models only) 	<ul style="list-style-type: none"> Door locked Water level below anti-flooding level Maximum time 5 minutes 	Water ducted through conditioner/stains compartments	Displays the water level in tub
6 	<ul style="list-style-type: none"> - Door interlock - Wash solenoid if the level of water in the tub does not cover the heater - Heating element - Recirculation pump 	<ul style="list-style-type: none"> Door locked Water level above the heater Maximum time 10 minutes or up to 90°C (*) 	Heating Recirculation	Wash water temperature
7 	<ul style="list-style-type: none"> - Door interlock - Wash solenoid if the level of water in the tub does not cover the heater - Motor (55 rpm clockwise, 55 rpm counter-clockwise, 250 rpm impulse) 	<ul style="list-style-type: none"> Door locked Water level above the heater 	Check for leaks from the tub	Displays the drum speed (the real value divided by ten)
8 	<ul style="list-style-type: none"> - Door interlock - Drain pump - Motor up to 650 rpm then at maximum spin speed (**) 	<ul style="list-style-type: none"> Door locked Water level lower than anti-boiling level for spinning 	Drain and spin; control of congruence in closure of level pressure switches	Displays the drum speed (the real value divided by ten)
9 	<ul style="list-style-type: none"> - Door interlock - Drain pump - Motor fan - Condensation solenoid valve - Drying heating element 	<ul style="list-style-type: none"> Door locked Water level lower than anti-boiling level 	Drying	Displays the air temperature

10		- Reading/Cancellation of the last alarm	-----	-----	
----	---	--	-------	-------	--

- (*) In most cases, this time is sufficient to check the heating. However, the time can be increased by repeating the phase without draining the water: pass for a moment to a different phase of the diagnostic cycle and then back to the heating control phase (if the temperature is higher than 80°C, heating does not take place).
- (**) The check at the maximum speed occurs without control of the FUCS and no clothes have to be inserted inside the appliance.

5 ALARMS

5.1 Displaying the alarms to the user

The alarms displayed to the user are listed below:

- ↵ **Door open**
- ↵ **Drain difficulty (dirty filter)**
- ↵ **Water fill difficulty (closet tap)**

AEG Version

The alarms are represented through the flashing of the yellow LED, which is above the START-PAUSE button, and can be solved directly by the end user;



Other versions

The alarms are represented through the flashing of the red LED, which is inside the START-PAUSE button its shape depends on the styling) and can be solved directly by the user;

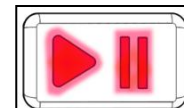

The alarm listed below:

- ↵ **EF0 – Water leakage (Aqua Control System)**
for its solution it is necessary the intervention of the Service.

While for the alarm:

- ↵ **Eb0/EH0 – Voltage or frequency out of nominal values**
It is necessary to wait that the voltage and/or the frequency of the electric line reset the nominal conditions.

The alarms are enabled during the execution of the washing programme, with the exception of alarms associated with configuration and the power supply (voltage/frequency), which are also displayed during the programme selection phase.

The door can normally be opened (except where specified) when an alarm condition has occurred on condition that:

- The level of the water in the tub is below a certain level
- Water temperature lower than 55°C
- Motor stopped

Certain alarm conditions require that a drain phase be performed before the door can be opened for safety reasons:

- Cooling water fill if the temperature is higher than 65°C
- Drain until the analogue pressure switch is on empty, during a max. 3-minute time.

5.2 Reading the alarm codes

It is possible to display the last three memorised alarms in the FLASH memory of the electronic board:

- Enter diagnostic mode (par. 4.1)
- Irrespective of the type of PCB and configuration:
turn the programme selector **clockwise** (version with knob) pushing button **P1** (version INPUT) to the **tenth position**.

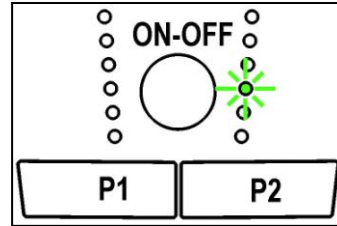
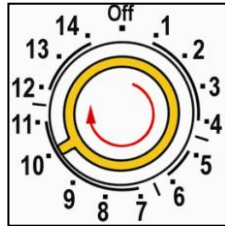

- The last alarm is displayed.
- To display the previous alarms, press sequentially the left button of the START/PAUSE button (as represented in figure).

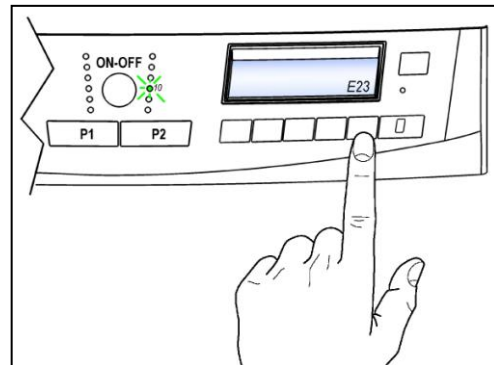
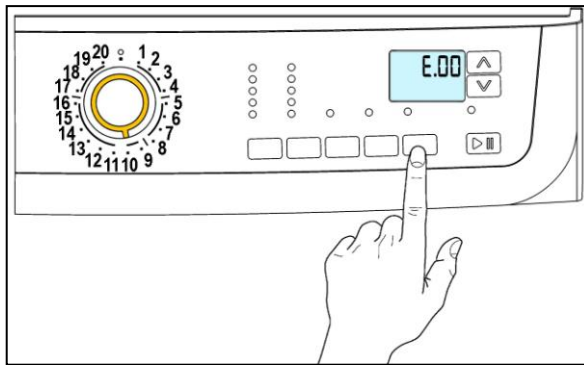

- To return to the last alarm, press the START/PAUSE button.

5.2.1 Alarm displaying

AEG Version:

The alarm is displayed by a repeated flashing sequence of the LED placed above the button START / PAUSE with yellow and red light (0.5 seconds on, 0.5 seconds off with a 2.5 second pause between the sequences).

- LED indicator START / PAUSE with yellow light → indicates the first digit of the alarm code (family).
- LED indicator START / PAUSE with red light → indicates the second digit of the alarm code (internal number of the family).

These two LEDs are featured in all models.



Other versions:

The alarm is displayed by a repeated flashing sequence of the START / PAUSE button with red and green light (0.5 seconds on, 0.5 seconds off with a 2.5 second pause between the sequences).

- LED indicator START / PAUSE with red light → indicates the first digit of the alarm code (family)
- LED indicator START / PAUSE with green light → indicates the second digit of the alarm code (internal number of the family)

These two LEDs are featured in all models.

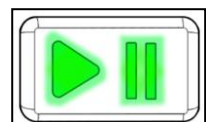
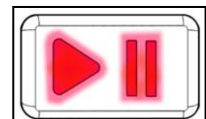

Notes:

- The first letter of the alarm code “E” (Error) is not displayed, since this letter is common to all alarm codes.
- The alarm code “families” are shown in hexadecimal; in other words:
 - **A** is represented by **10** flashes
 - **b** is represented by **11** flashes (appliances with LEDs)
 - **H** is represented by **11** flashes (appliances with LCD / DISPLAY)
 - ...
 - **F** is represented by **15** flashes
- Configuration errors are shown by the flashing of all the LEDs (user interface not configured).

5.2.2 Examples of alarm display

Example: Alarm E43 (problems with the door interlock Triac) will display the following:

- the sequence of four flashes of the START / PAUSE button with red light (version AEG LED yellow light), indicates the first number **E43**;
- the sequence of three flashes of the START / PAUSE button with green light (version AEG LED red light), indicates the second number **E43**;

START / PAUSE button with red light				START / PAUSE button with green light			
ON/OFF	On/Off (Ver. AEG)	Time (Sec.)	Value	ON/OFF	On/Off (Ver. AEG)	Time (Sec.)	Value
		0.5	1			0.5	1
		0.5				0.5	
		0.5	2			0.5	2
		0.5				0.5	
		0.5	3			0.5	3
		0.5				0.5	
		0.5	4			2.5	Pause
		0.5					
		1.5	Pause				

5.2.3 Operation of alarms during diagnostics

All alarms are enabled during the components diagnostic phase.

5.3 Rapid reading of alarm codes

The last three alarm codes can be displayed even if the programme selector is not in the tenth position (diagnostics) or if the appliance is in normal operating mode (e.g. during the execution of the washing programme):

- Press and hold down **START/PAUSE** and the nearest **option button** (as to enter the DIAGNOSTICS), for at least two seconds: the LEDs initially switch off, and then display the flashing sequence indicating the last alarm.
- The alarm continues to be displayed for the amount of time required, and then the display returns to its normal operation.
- The alarm reading system is as described in para. 5.2.
- While the alarm is being displayed, the appliance continues to perform the cycle or, if in the programme selection phase, it maintains the previously selected options stored in the memory.

5.4 Cancelling the last alarm

It is good practice to cancel the last alarm:

- after reading the alarm code, to check whether the alarm re-occurs during diagnostics;
- after repairing the appliance, to check whether it re-occurs during testing.

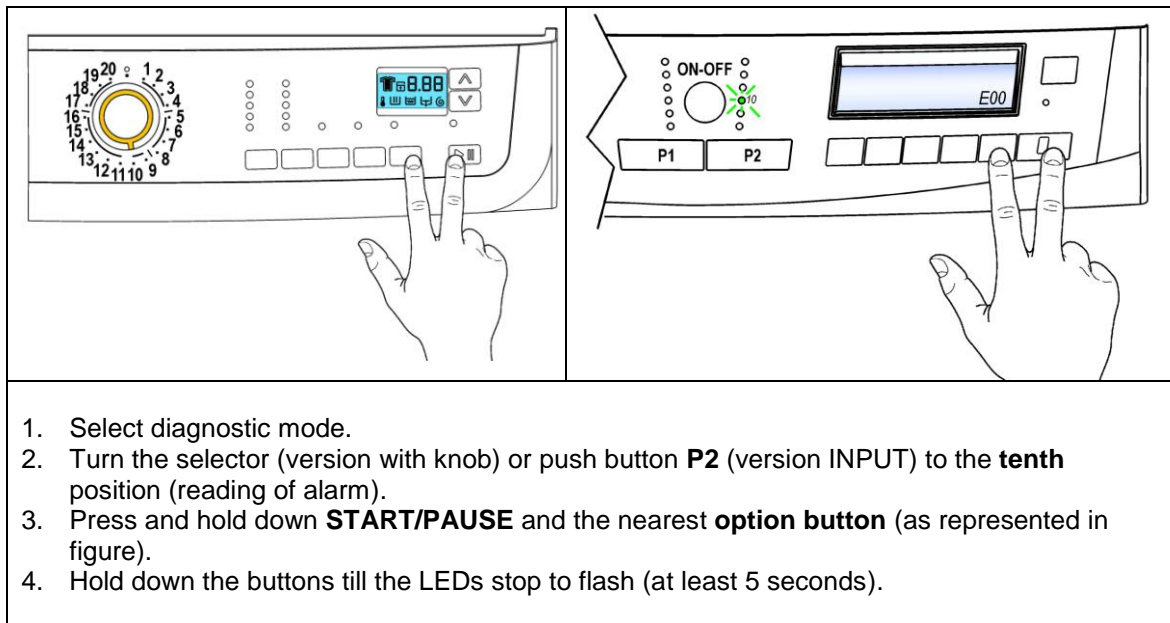

N.B. With this operation all the memorised alarms are deleted.

5.5 TABLE OF ALARMS

Alarm	Possible fault	Action/machine status	Reset	Alarm	Page
E00	No alarm	-----	-----	-----	-----
E11	Difficulties in water fill for washing	Tap closed or water pressure too low; Drain tube improperly positioned; Water fill solenoid valve is faulty; Leaks from water circuit on pressure switch; Pressure switch faulty; Wiring faulty; PCB faulty.	Cycle is paused with door locked.	START/RESET	23
E12	Difficulties in water fill for drying	Tap closed or water pressure too low; Drain tube improperly positioned; Water fill solenoid valve is faulty; Leaks from water circuit on pressure switch; Pressure switch faulty; Wiring faulty; PCB faulty.	Cycle is paused with door locked.	START/RESET	25
E13	Water leakage	Drain hose incorrectly positioned; mains pressure insufficient; water fill solenoid faulty; leakage/blockage of pressure switch hydraulic circuit; pressure switch faulty.	Cycle is paused with door locked.	START/RESET	26
E21	Difficulties in draining for washing	Drain tube kinked/clogged/improperly positioned; Drain filter clogged/dirty; Drain pump faulty; Pressure switch faulty; Wiring faulty; PCB faulty.	Cycle is paused (after 2 attempts).	START/RESET	28
E22	Difficulties in draining for drying	Drain tube kinked/clogged/improperly positioned; Drain filter clogged/dirty; Drain pump faulty; Pressure switch faulty; Wiring faulty; PCB faulty.	Cycle is paused.	START/RESET	30
E23	Drain pump triac faulty	Drain pump faulty; Wiring faulty; PCB faulty.	Safety drain cycle - Cycle stops with door unlocked.	RESET	32
E24	Fault in "sensing" circuit of drain pump triac (wrong input signal to microprocessor)	PCB faulty.	Safety drain cycle - Cycle stops with door unlocked.	RESET	33
E31	Electronic pressure switch circuit faulty (frequency of pressure switch signal out of limits)	Electronic pressure switch; Wiring; PCB faulty.	Cycle blocked with door closed.	RESET	33
E32	Incorrect calibration of electronic pressure switch (The electronic pressure switch generates a signal with instable frequency during the drain phase)	Drain tube kinked/clogged/improperly positioned; Drain filter clogged/dirty; Drain pump faulty; Leaks from water circuit on pressure switch; Pressure switch; Wiring faulty; PCB faulty.	Cycle is paused.	START/RESET	34
E35	Water overflow	Water fill solenoid faulty; Leaks from water circuit on pressure switch; pressure switch faulty; wiring faulty; PCB faulty.	Cycle blocked. Safety drain cycle. Drain pump always in operation (5 minutes on, 5 minutes off etc.).	RESET	35
E38	Pressure chamber blocked (water level does not vary for at least 30 sec. during drum rotation)	Motor drive belt broken; Hydraulic circuit pressure switch clogged.	Heating phase skipped.	ON/OFF RESET	36
E3A	Heating elem. relay sensing faulty (input signal to microprocessor always 0V or 5V)	PCB faulty.	Cycle blocked with door closed.	RESET	37
E41	Door open (after 15 sec.)	Door interlock faulty; wiring faulty; PCB faulty.	Cycle paused.	START/RESET	38÷41

Alarm	Possible fault	Action/machine status	Reset	Alarm	Page
E42	Problems of door closure	Door interlock faulty; wiring faulty; PCB faulty.	Cycle paused.	START/RESET	42÷44
E43	Interlock power supply triac faulty	Door interlock faulty; wiring faulty; PCB faulty.	(Safety drain cycle) Cycle blocked.	ON/OFF RESET	46÷47
E44	Door interlock sensing circuit triac faulty	PCB faulty.	(Safety drain cycle) Cycle blocked.	ON/OFF RESET	48
E45	Door interlock sensing circuit triac faulty (wrong input signal to microprocessor)	PCB faulty.	(Safety drain cycle) Cycle blocked.	ON/OFF RESET	48
E51	Motor power supply triac short-circuited	PCB faulty; current leakage from motor or from wiring.	Cycle blocked, door locked (after 5 attempts).	RESET	49
E52	No signal from motor tachometric generator	Motor faulty; wiring faulty; PCB faulty.	Cycle blocked, door locked (after 5 attempts).	RESET	50÷53
E53	Motor triac sensing circuit faulty (input signal to microprocessor wrong)	PCB faulty.	Cycle blocked, door locked.	RESET	54
E54	Motor relay contacts sticking (high voltage level when the relay changes to OFF)	PCB faulty; current leakage from motor or from wiring.	Cycle blocked, door locked (after 5 attempts).	RESET	55
E61	Insufficient heating during washing	NTC sensor faulty; heating element faulty; wiring faulty; PCB faulty.	The heating phase is skipped.	START/RESET	56
E62	Overheating during washing (temperature higher than 88°C for a time higher than 5 min.)	NTC sensor faulty; heating element faulty; wiring faulty; PCB faulty.	Safety drain cycle – Cycle stopped with door open.	RESET	57÷58
E66	Heating element power relay faulty (incongruence between sensing and relay)	PCB faulty.	Safety drain cycle – Cycle stopped with door open.	RESET	59÷60
E68	Current dispersion to earth (value of mains voltage different from main value)	Current dispersion between between heating element and earth.	Cycle blocked with door open.	RESET	61÷62
E69	Heating element interrupted	Wiring faulty; Heating element for washing interrupted (thermofuse open). Main circuit board faulty.	-----	START/RESET	63÷64
E71	Washing NTC sensor faulty (short-circuited or open)	Wiring faulty; Washing NTC sensor faulty; PCB faulty.	The heating phase is skipped.	START/RESET	65
E72	Drying condenser NTC sensor faulty (voltage value out of limits, sensor short-circuited or open)	Wiring faulty; Drying NTC sensor (condenser) badly positioned or faulty; WD board faulty.	The drying heating phase is skipped.	START/RESET	66
E73	Drying duct NTC sensor faulty (voltage value out of limits, sensor short-circuited or open)	Wiring faulty; Drying NTC sensor (duct) badly positioned or faulty; WD board faulty.	The drying heating phase is skipped.	START/RESET	67
E74	Washing NTC sensor badly positioned	Wiring faulty; Washing NTC sensor badly positioned; NTC sensor faulty; PCB faulty.	The heating phase is skipped.	START/RESET	68
E82	Error in selector reset position	PCB faulty (Wrong configuration data).	-----	RESET	69
E83	Error in selector reading	PCB faulty (Wrong configuration data).	Cycle cancelled.	START/RESET	70

Alarm	Possible fault	Action/machine status	Reset	Alarm	Page
E91	Communication error between PCB and display board	Wiring faulty; Control/display board faulty; PCB faulty.	-----	RESET	71
E92	Communication incongruence between main PCB- display board (versions not compatible)	Wrong control/display board; Wrong PCB (do not correspond to the model).	Cycle interrupted.	OFF/ON	71
E93	Incorrect configuration of appliance	PCB faulty; (Incorrect configuration data).	Cycle interrupted.	OFF/ON	71
E94	Incorrect configuration of washing cycle	PCB faulty; (Incorrect configuration data).	Cycle interrupted.	OFF/ON	71
E95	Communication error between microprocessor and EEPROM	PCB faulty.	Cycle interrupted.	RESET	71
E97	Incongruence between programme selector and cycle configuration	Faulty PCB (Wrong configuration data).	Cycle interrupted.	RESET	71
E9b/E9H*	Communication error between microprocessor and FLASH memory	Display board	-----	OFF/ON RESET	
EA1	Drum positioning (DSP) faulty	Motor belt broken; Wiring faulty; PCB faulty; DSP sensor faulty.	Positioning phase skipped.	ON/OFF RESET	72
EA6	DSP door opening faulty	Motor belt broken; Wiring faulty; Drum cover open. Motor faulty; PCB faulty.	Cycle paused.	ON/OFF RESET	73
Eb1/EH1*	Frequency power of appliance out of limits	Power supply problems (incorrect / disturbance); PCB faulty.	Wait for frequency nominal conditions.	OFF/ON	74
Eb2/EH2*	Voltage too high	Power supply problems (incorrect / disturbance); PCB faulty.	Wait for frequency nominal conditions.	OFF/ON	74
Eb3/EH3*	Voltage too low	Power supply problems (incorrect / disturbance); PCB faulty.	Wait for frequency nominal conditions.	OFF/ON	74
EF1	Drain filter blocked (drain phase too long)	Drain tube blocked/kinked/too high; Drain filter dirty/blocked.	Warning displayed at the end of cycle (specific LED).	START/RESET	75
EF2	Excessive detergent dosing (excessive foam during draining)	Excessive detergent dosing; drain tube kinked/blocked; Drain filter dirty/blocked.	Warning displayed after 5 attempts or by the specific LED.	RESET	75
EF3	Aqua control intervention	Water leaks onto base frame; water control system defective.	Water drain.	ON/OFF RESET	75
EF4	Water fill pressure low, no signal of flowmeter and solenoid valve open	Tap closed; water fill pressure low.	-----	RESET	75
EF5	Unbalanced load	Final spin phases skipped.	-----	RESET	75
EF6	Reset	-----	No action to be performed, if continues replace the PCB.	-----	75
EC1	Solenoid valve blocked with flowmeter working	Wiring faulty; Solenoid valve faulty/blocked, PCB faulty.	Cycle blocked with door closed. Drain pump always works (5 min., then it stops for 5 min. ecc.).	RESET	76
Ed1	Data communication error between WD board and PCB	Wiring faulty between PCB and WD board; WD board faulty; PCB faulty.	Cycle interrupted.	OFF/ON	77
Ed2	Drying heating element relay 1 faulty	Wiring faulty between WD board and thermostats; thermostats faulty; WD board faulty, PCB faulty.	Cycle blocked with door open.	RESET	78
Ed3	Drying heating element relay 2 faulty	Wiring faulty between WD board and thermostats; thermostats faulty; WD board faulty, PCB faulty.	Cycle blocked with door open.	RESET	81

Alarm	Possible fault	Action/machine status	Reset	Alarm	Page
Ed4	Relay which commutates power between washing heating element and drying (in the WD board)	Wiring faulty; WD board faulty; PCB faulty.	Cycle blocked with door open.	RESET	82
Ed6	No communication between PCB and display board (INPUT)	Wiring faulty between PCB and programme display board; PCB faulty.	-----	OFF/ON	84

* See page 15

5.6 Notes concerning certain alarm codes

- **Configuration alarms E93:** If this alarm is generated (when the appliance is switched on), operation of the appliance is blocked, the LEDs placed above or inside the START/PAUSE button start to flash displaying the complete codification (family plus alarm), the display shows the alarm code on condition that the configuration part of the display is ok.
The diagnostic procedure cannot be accessed; the only option is to switch the appliance OFF.
- **Configuration alarm E94:** all LEDs placed above or inside the START/PAUSE button start to flash displaying the complete codification (family plus alarm) and the code is displayed.
It is not possible to enter the diagnostics or to use the mode “rapid displaying of the alarm”.
- **Alarms EH1(Eb1)-EH2(Eb2)-EH3(Eb3):** In the event of problems with the mains power supply, the appliance remains in alarm mode until the mains frequency or voltage are restored to the correct value or the appliance is switched off (programme selector on “0”). The family of alarm “**b or H**” only is displayed if the problem occurs during the normal operation of the appliance, while the family plus the alarm are displayed if the problem occurs at the switching on, through the flashing of the LEDs placed above or inside the START/PAUSE button. At the same time the code is represented also in the display. It is not possible to enter the diagnostics or to use the mode “rapid displaying of the alarm”: the complete alarm can be read only when the abnormal situation has terminated.
- **Alarms E51- E52:** During the diagnostic test, all the alarms are displayed. Normally, when the programme selector is turned from one test phase to another, the appliance exits the alarm condition and performs the phase selected. This does not take place in the case of alarms E51 (power triac on motor short-circuited) and E52 (no signal from the tachometric generator on the motor): in these cases, the only option to exit the alarm condition is to switch the appliance OFF by turning the selector to position “0” (reset) or pushing the ON/OFF button (INPUT styling).

6 THE DIAGNOSTIC PROGRAMME CANNOT BE ACCESSED

6.1.1 All LEDs on the circuit are board switched off

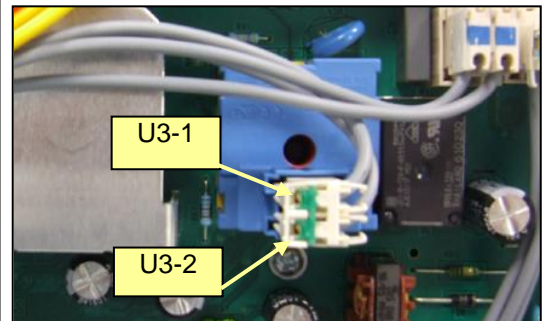
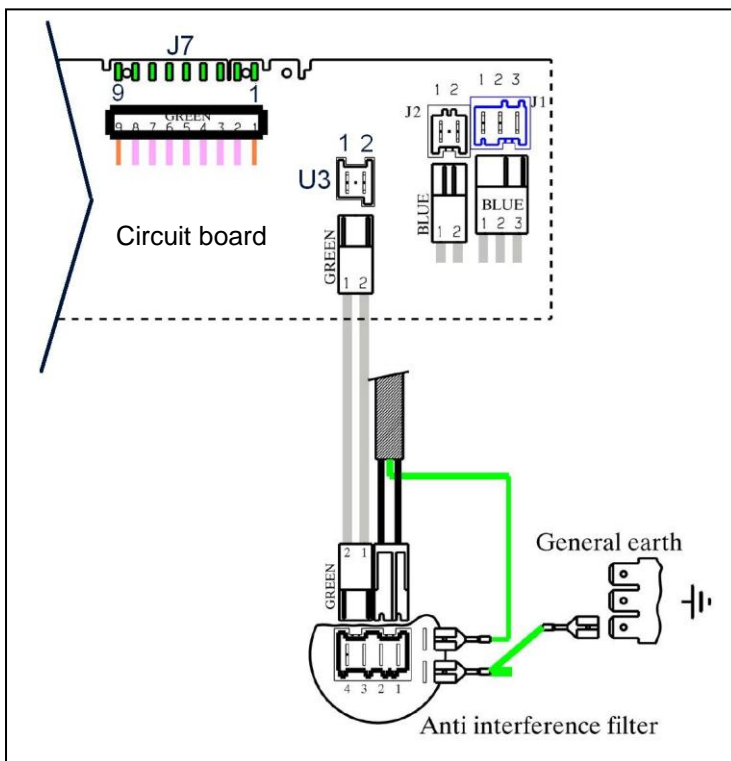
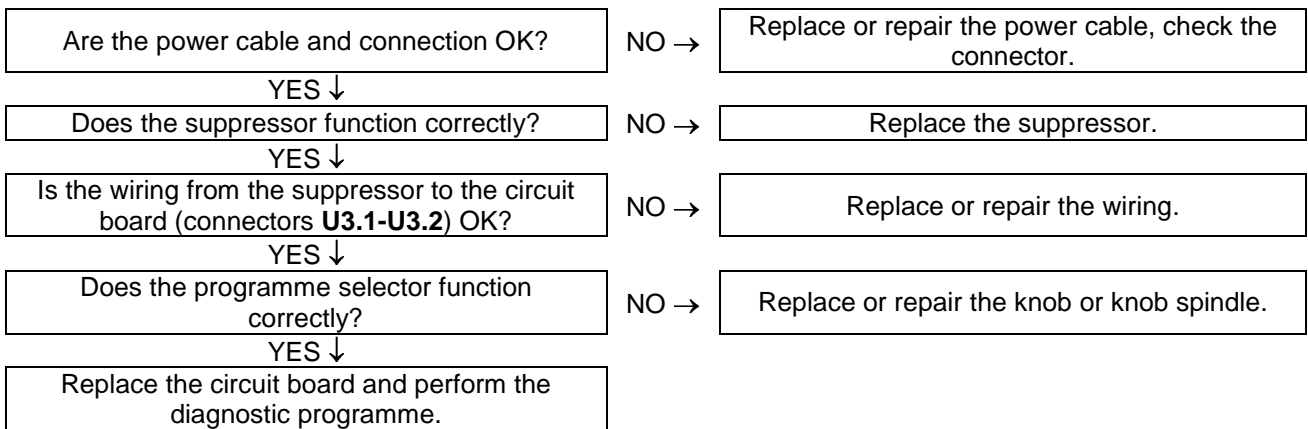

6.1.2 Some of the LEDs of the circuit board light

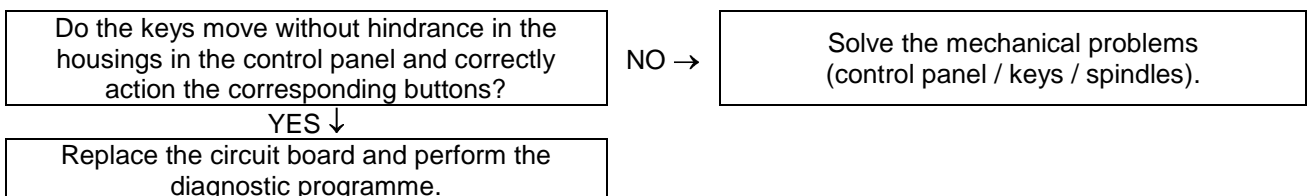

If there are traces of burning on the circuit board, refer to page 94

7 TROUBLESHOOTING ACCORDING TO ALARM CODES

E11	E11: Difficulty in filling water during washing phase	E11
	Maximum water fill time for each pressure switch level (this time is reset to zero each time the level is reached)	

Checks to perform: *Check that all the connectors are inserted correctly*

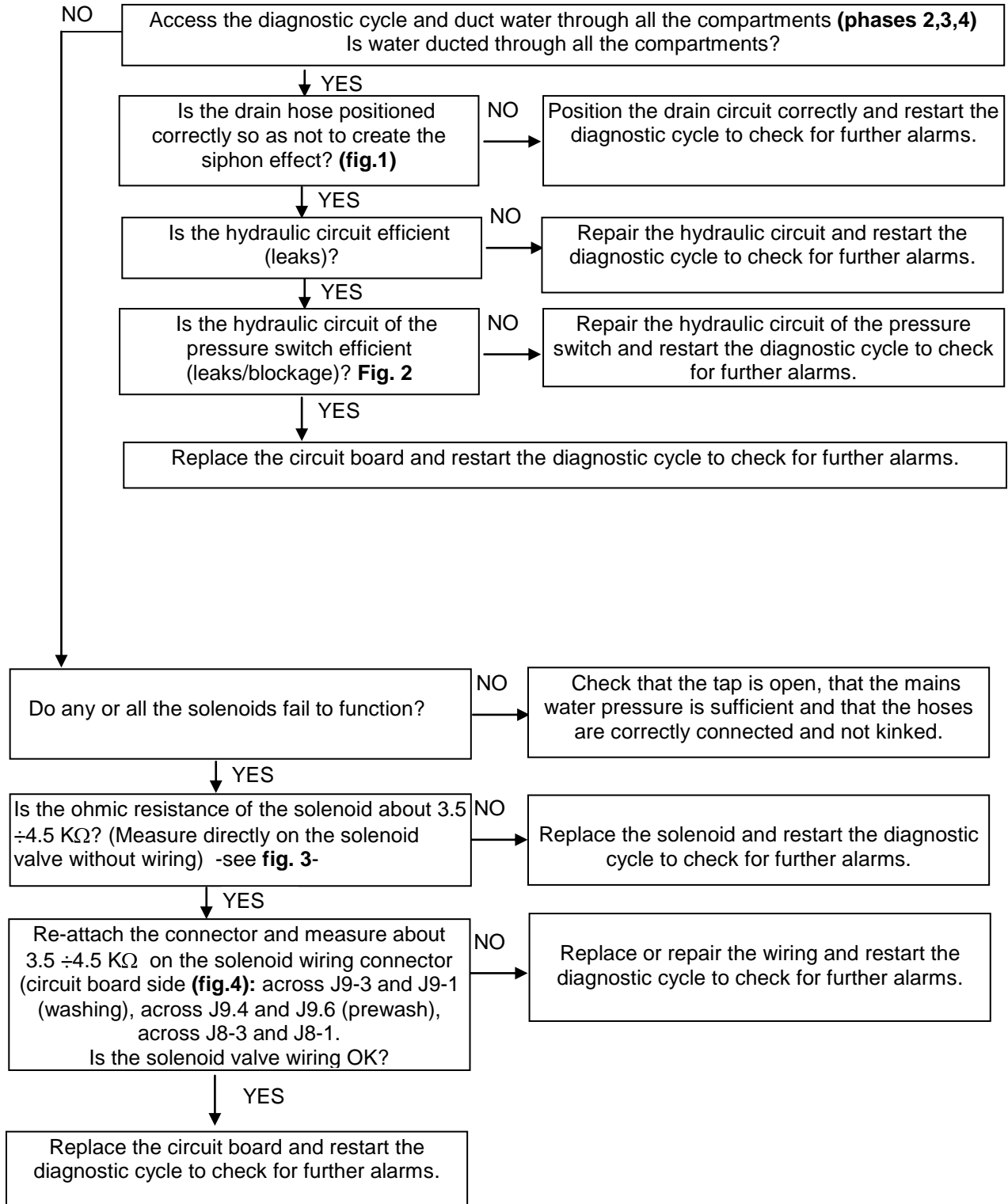

If there are traces of burning on the circuit board, refer to page 94

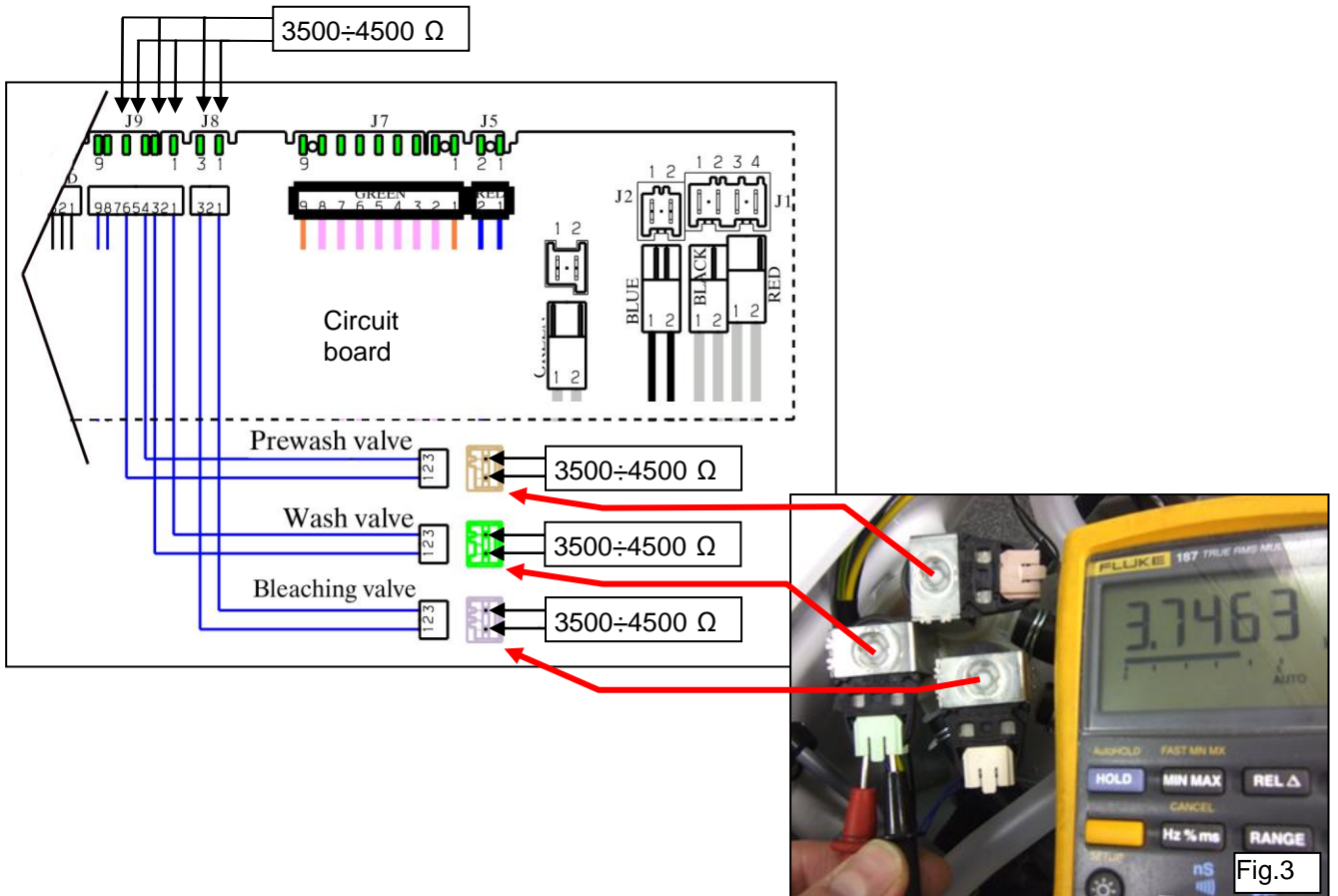
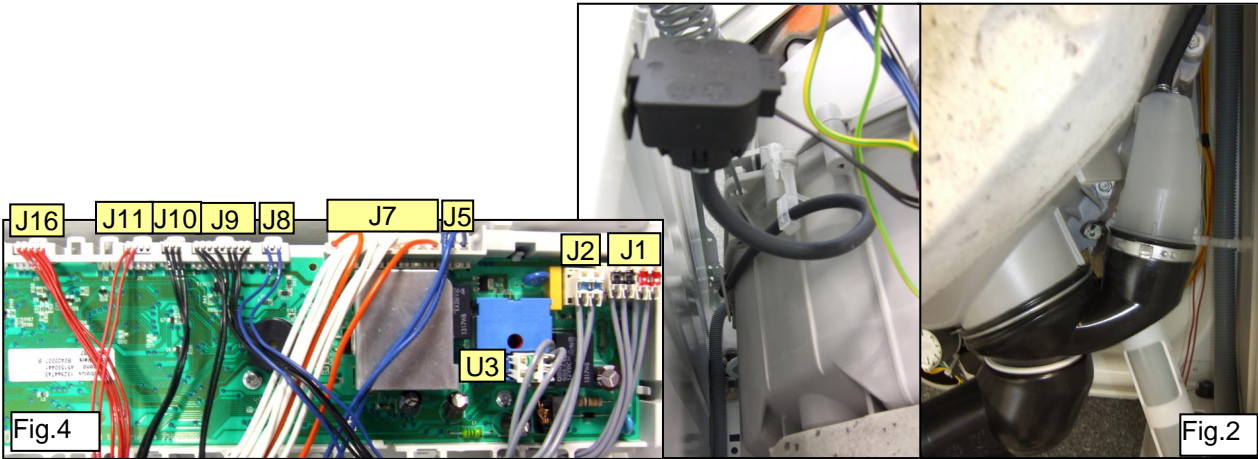
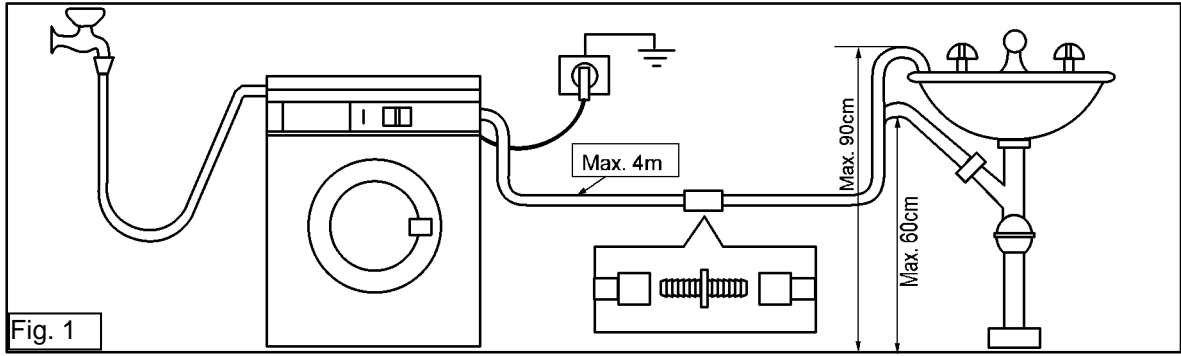

If there are traces of burning on the circuit board, refer to page 94

E12: Difficulty in filling water during drying phase		
E12	To check if the condensation valve is working, machine measures the increasing water level at the beginning of the drying phase. (Alarm appears after 10 min. of filling without reaching the level).	E12

Checks to perform: Check that all the connectors are inserted correctly

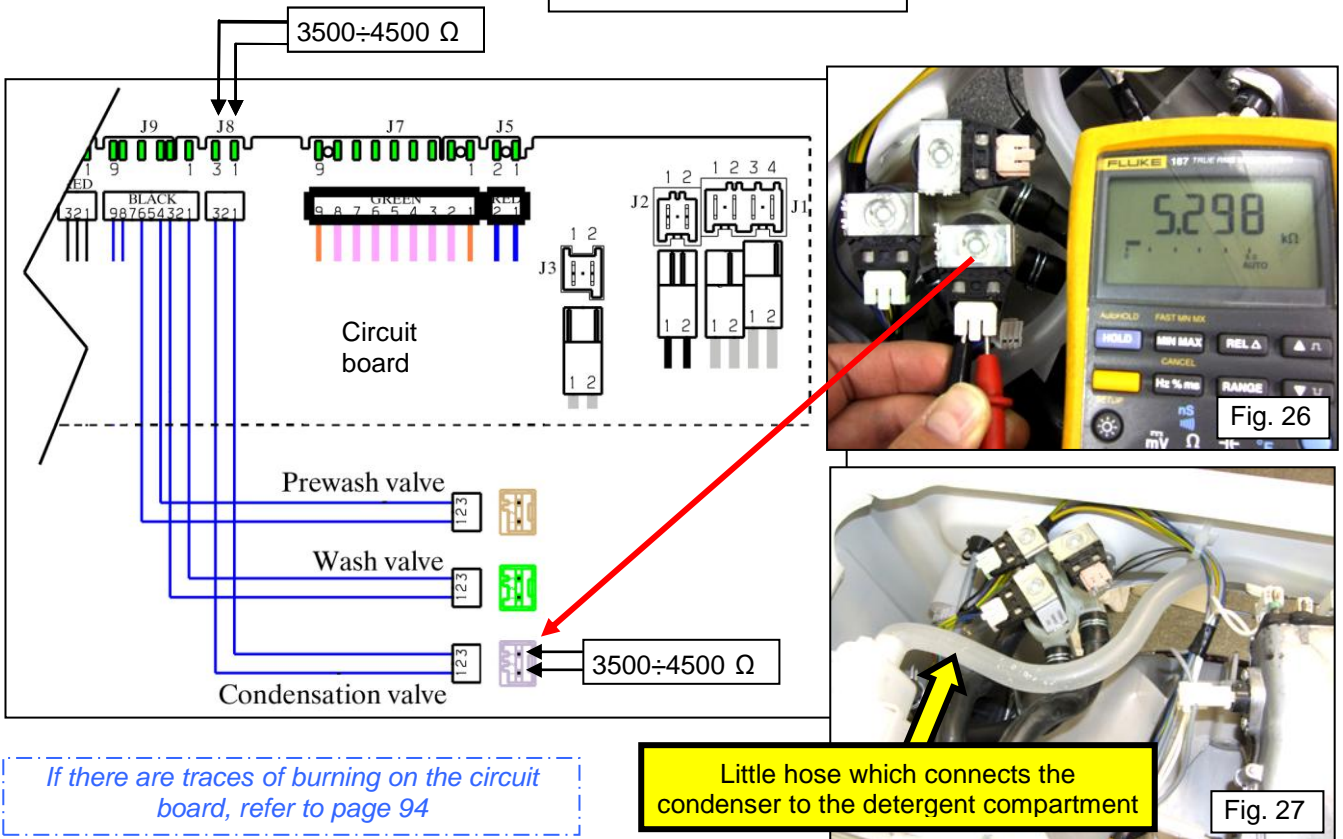
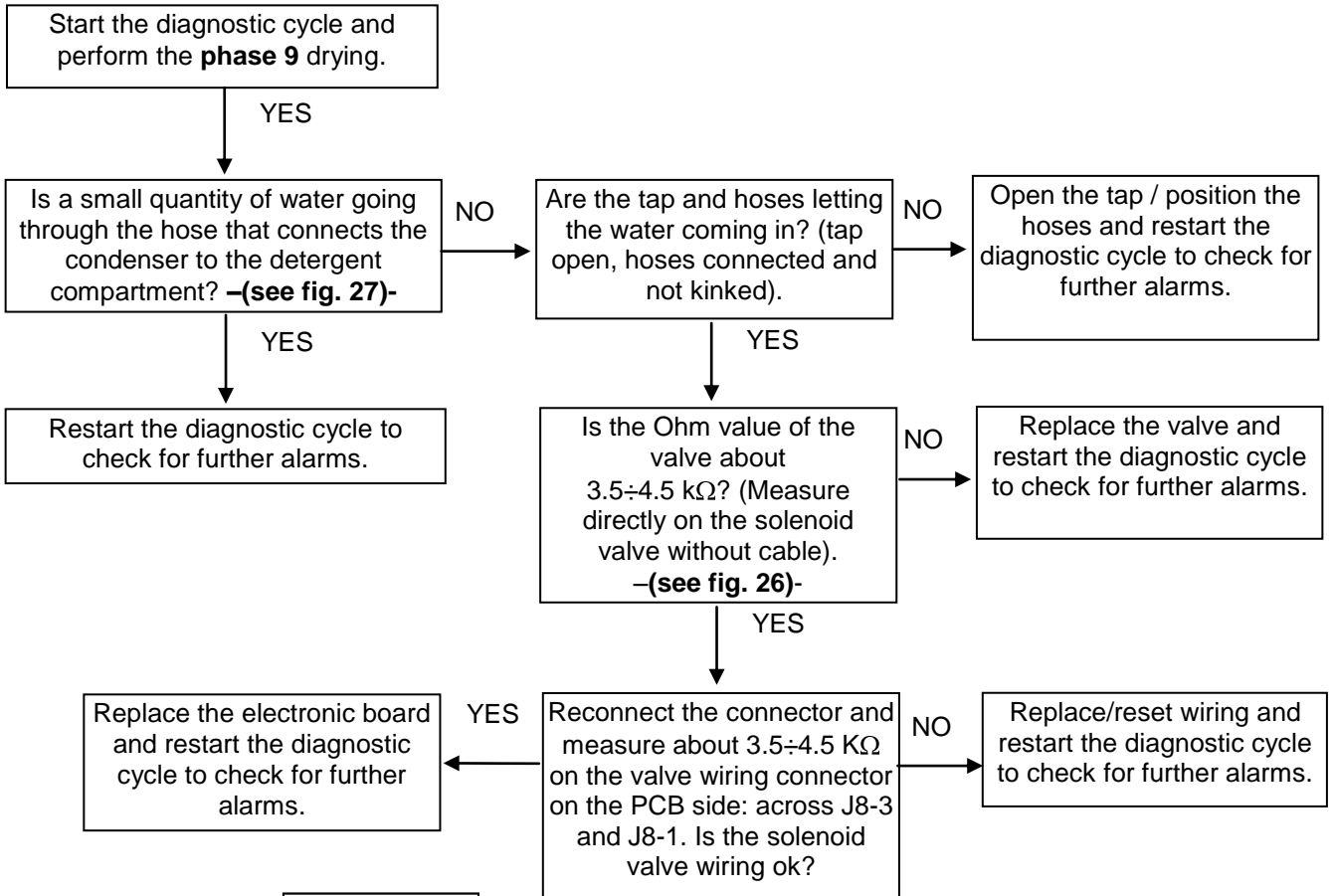

E13	E13: Water leakage	E13
	Overall maximum water fill time exceeded (the sum of all the water fills between one drain phase and the next, to avoid exceeding the maximum volume)	

Checks to perform: *Check that all the connectors are inserted correctly*

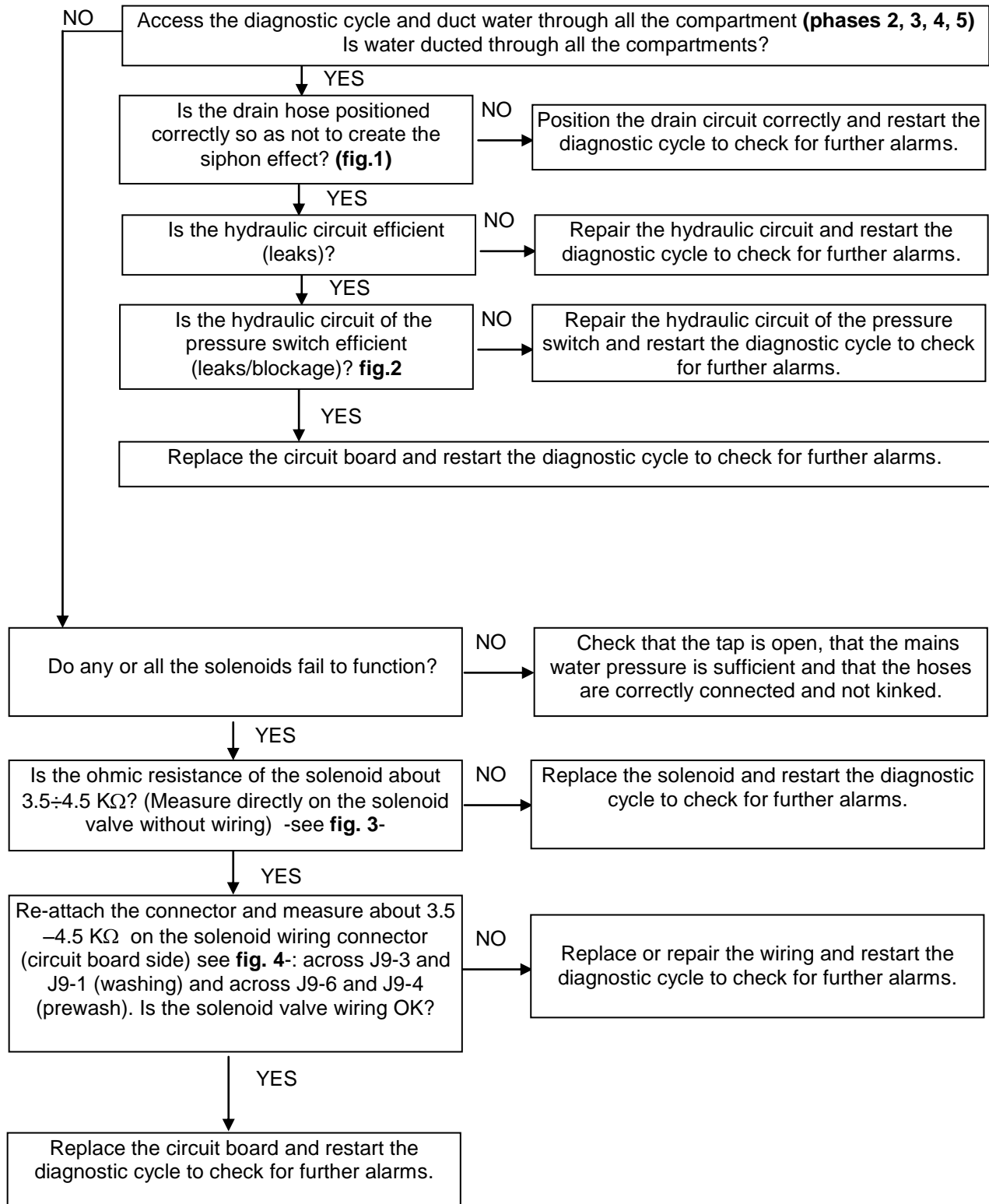

If there are traces of burning on the circuit board, refer to page 94

E13

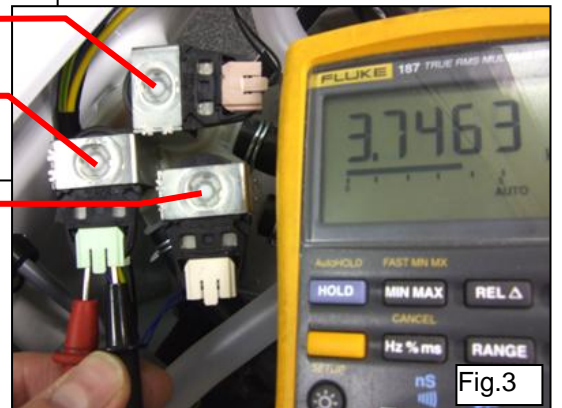
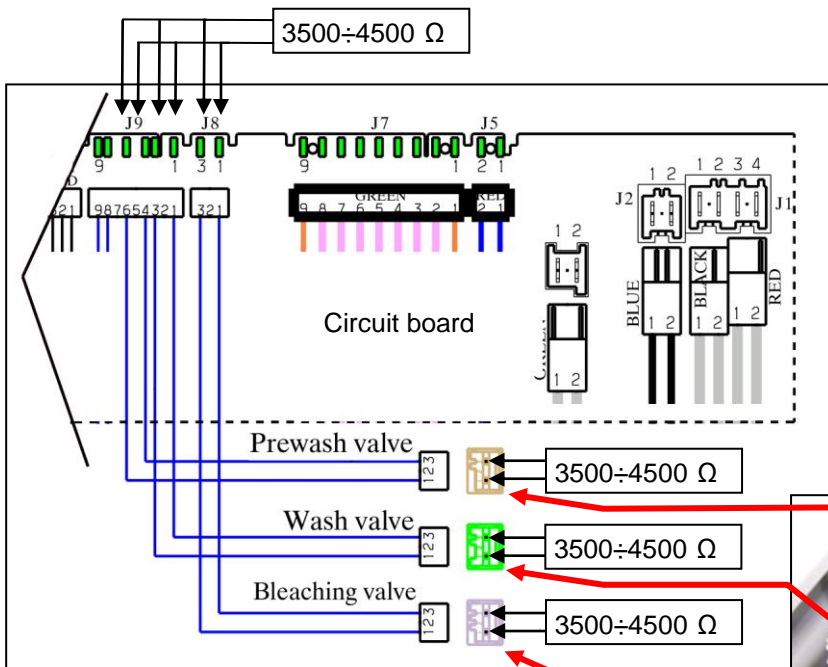
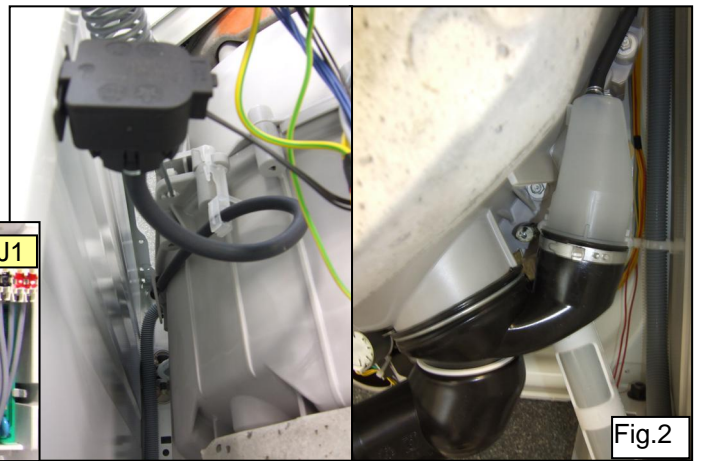
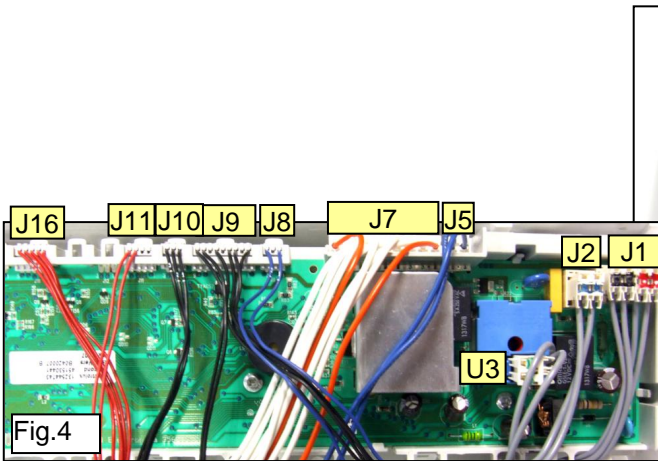
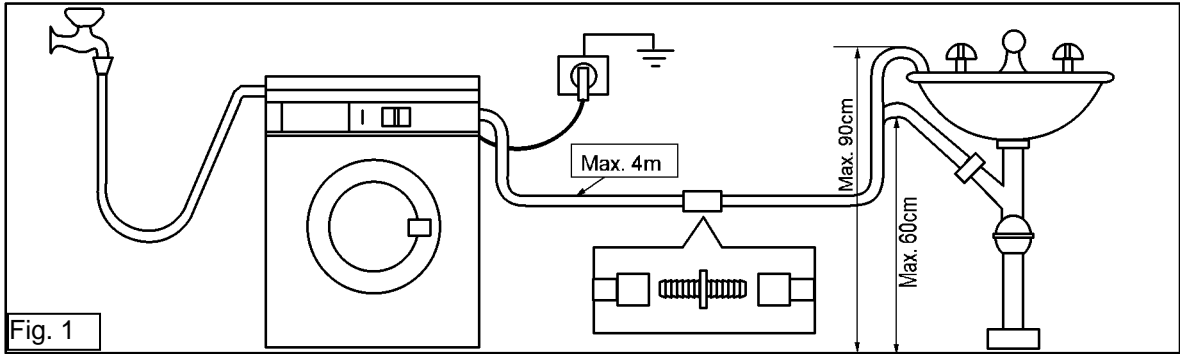

E21	E21: Difficulty in draining	E21
	Maximum drain time exceeded (measured for each phase of the cycle)	

Checks to perform: Check that all the connectors are inserted correctly

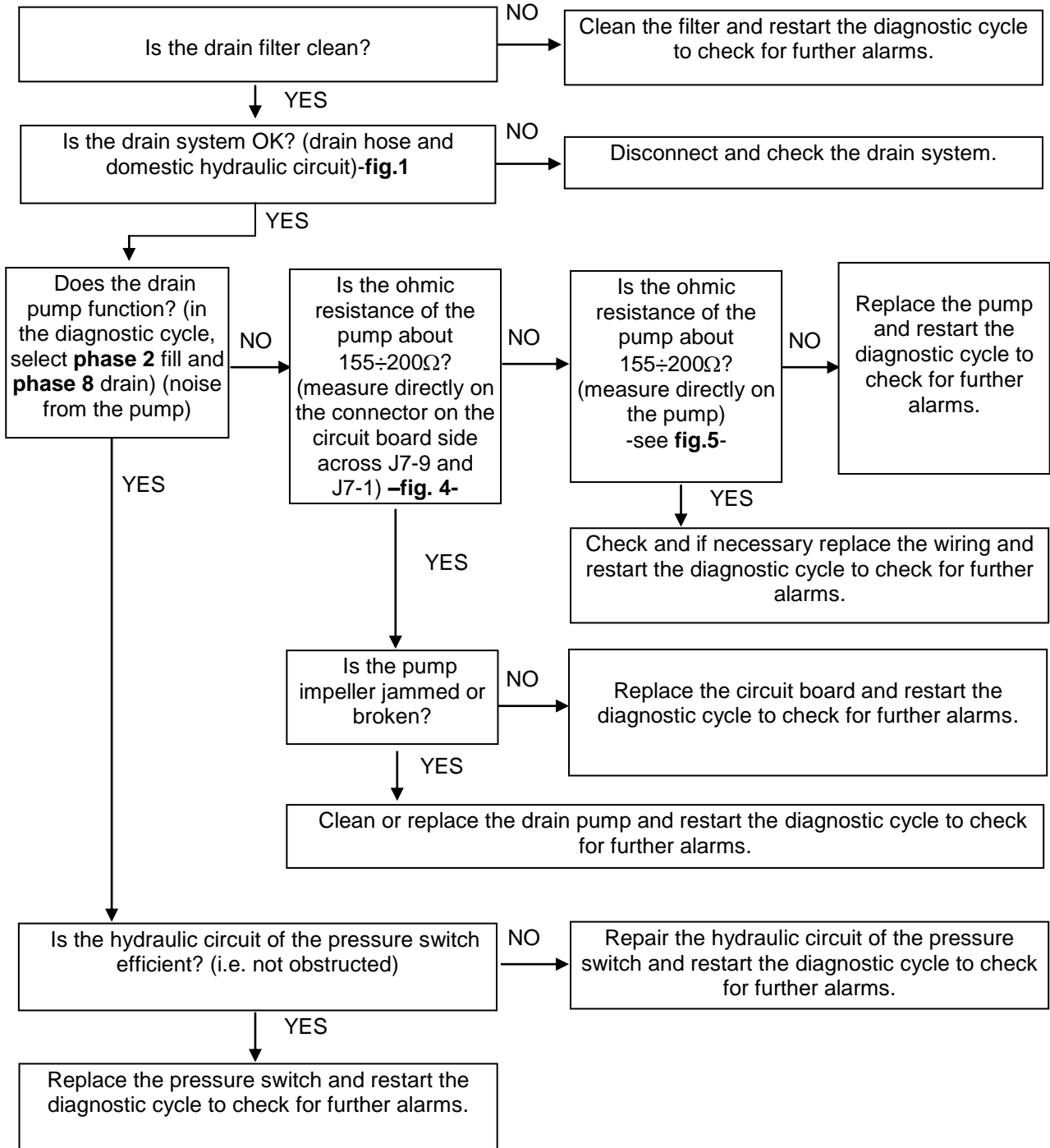

If there are traces of burning on the circuit board, refer to page 94

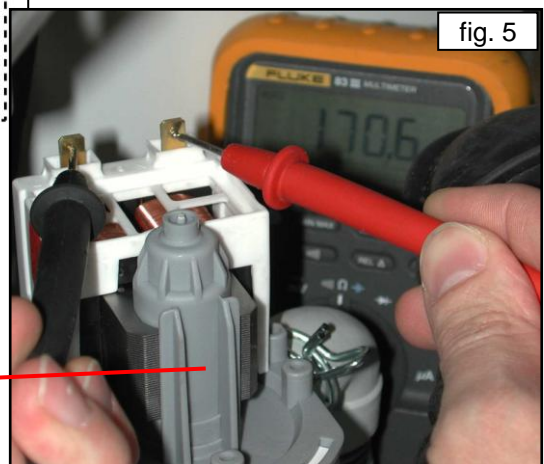
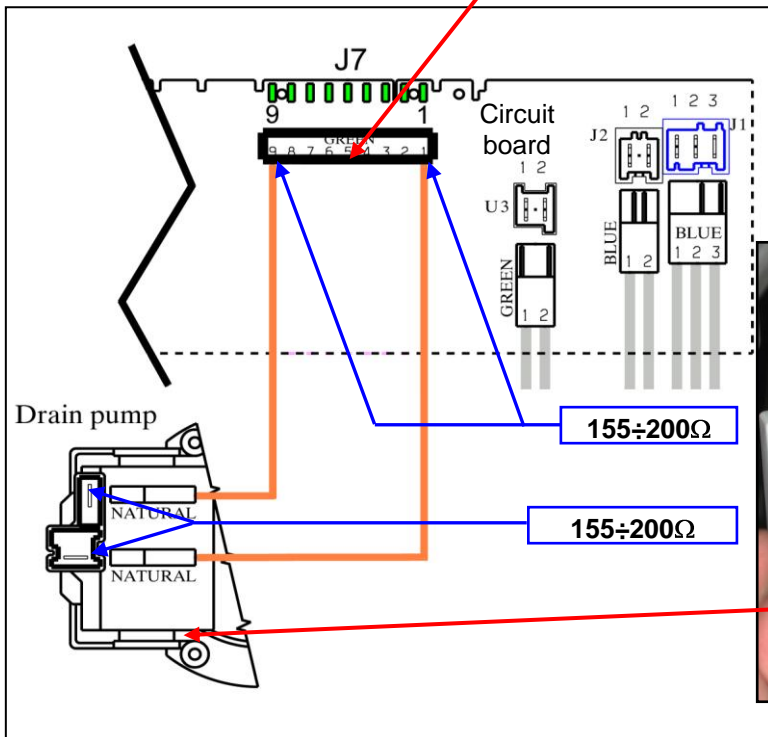
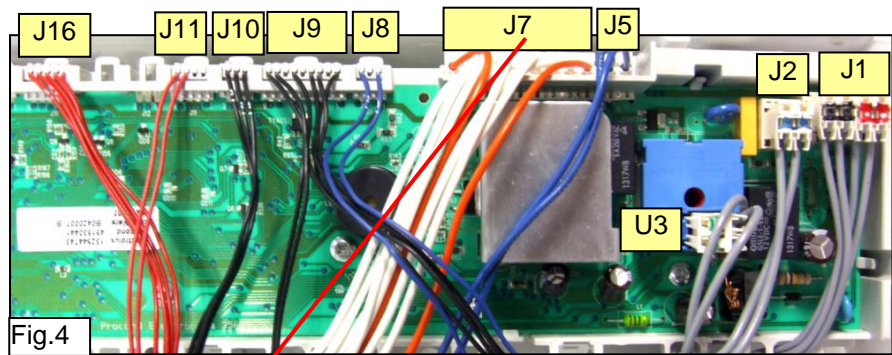
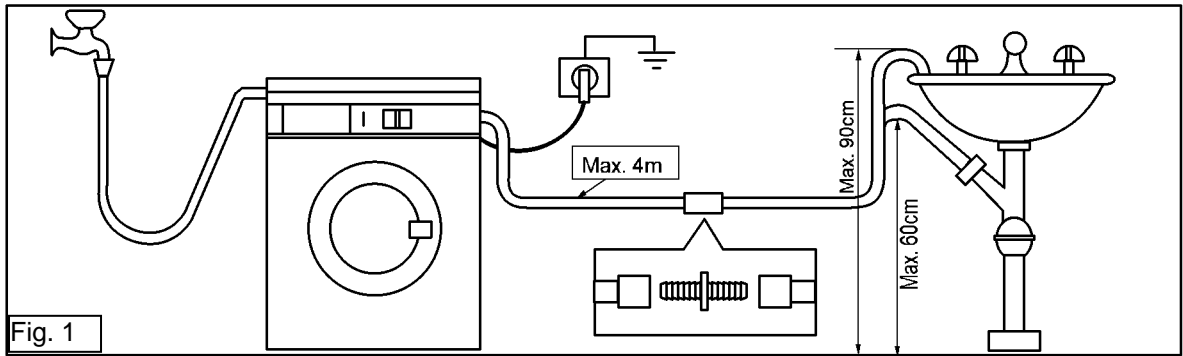

Checks to perform: Check that all the connectors are inserted correctly

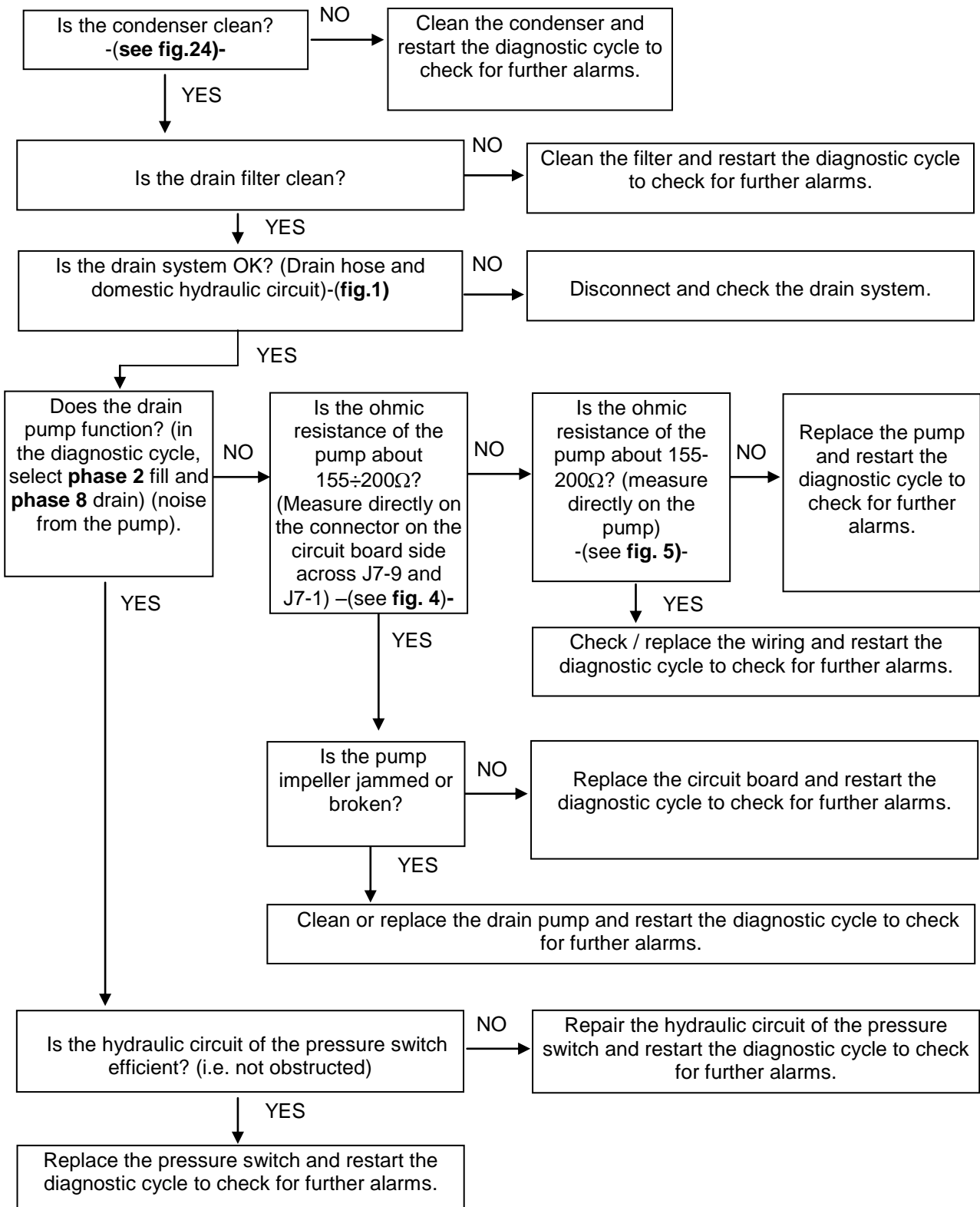

*If there are traces of burning on the
circuit board, refer to page 94*

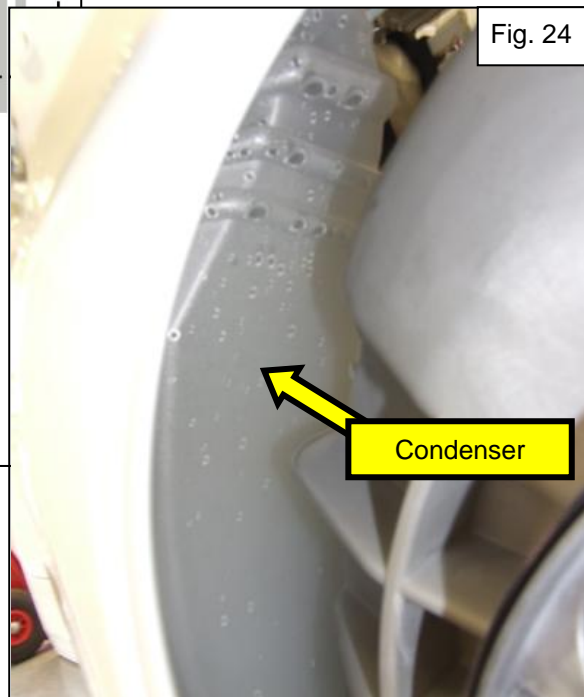
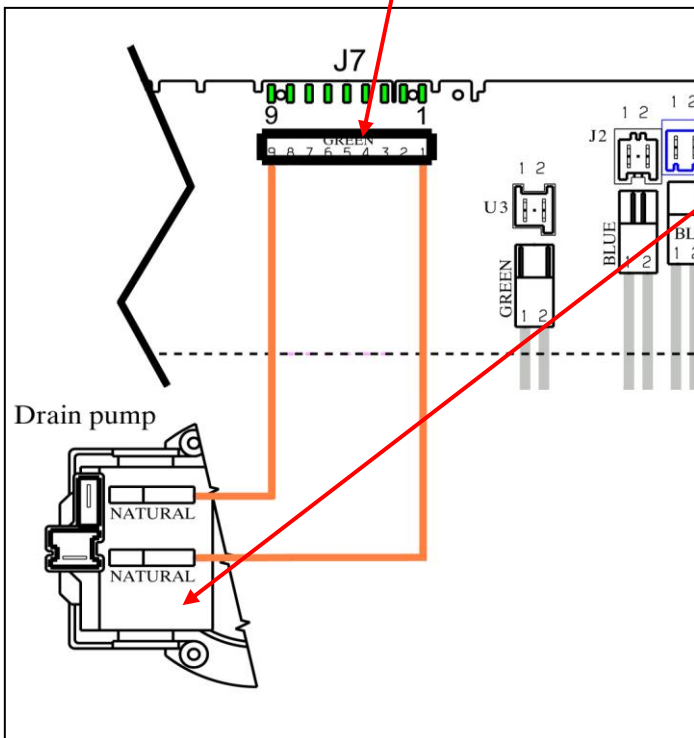
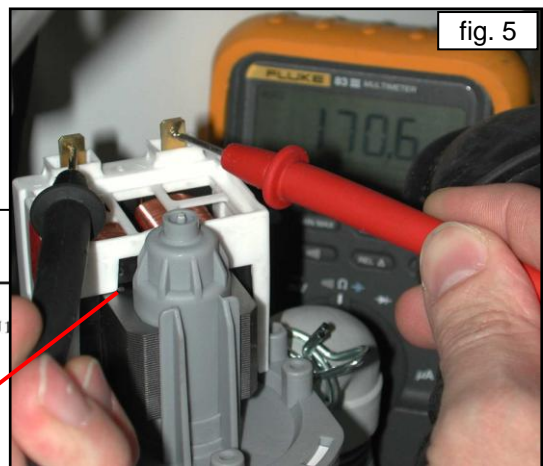
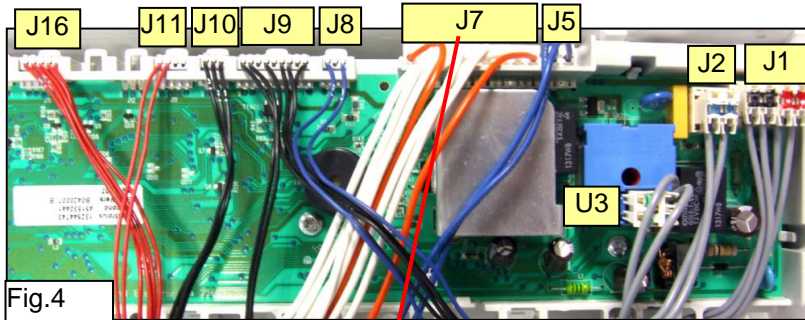
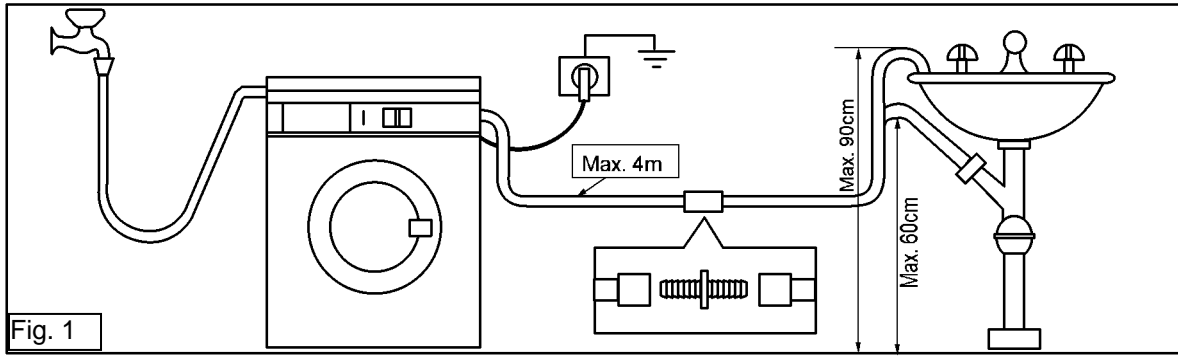

Checks to perform:

Check that all the connectors are inserted correctly

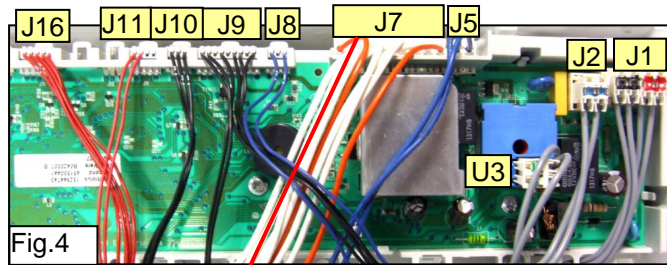
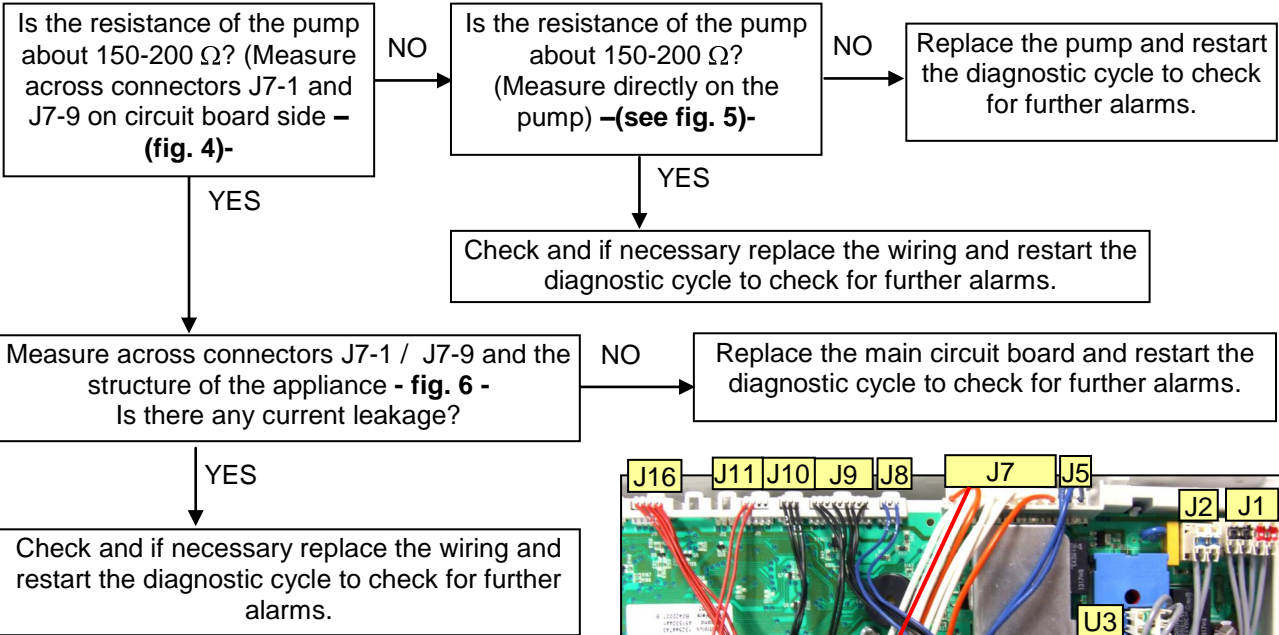

If there are traces of burning on the circuit board, refer to page 94

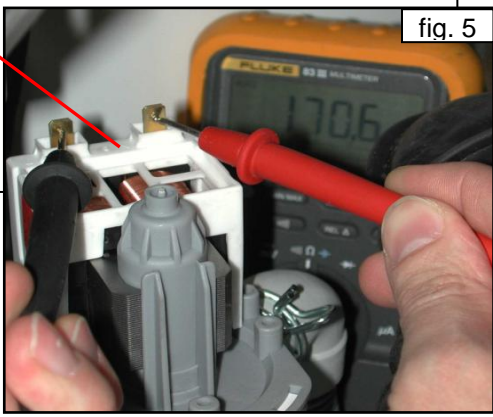
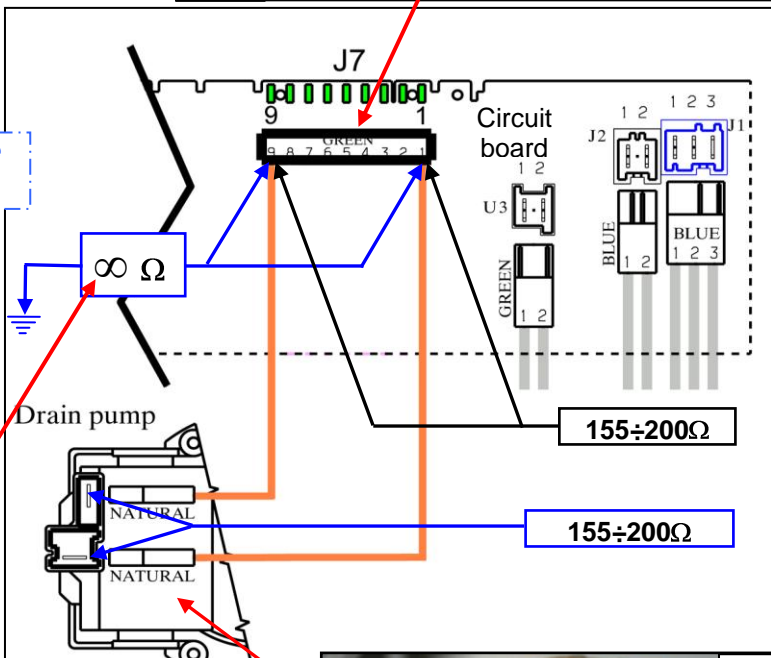

E24	E24: “Sensing” circuit of the component (triac) that controls the drain pump faulty	E24
------------	--	------------

Replace the circuit board and restart the diagnostic cycle to check for further alarms.

If there are traces of burning on the circuit board, refer to page 94

E31	E31: The analogic pressure switch is giving to the main board a signal outside the range	E31
------------	---	------------

Checks to perform: *Check that all the connectors are inserted correctly*

Measure a close circuit across J10-1, J10-2, J10-3 and the connector on analogic pressure switch (they are 3 independent connections **see fig. 7.**)
Is the cable between main board and analogic pressure switch OK and connected correctly on both sides?

NO → Reconnect and/or replace the cable and restart the diagnostic cycle to check for further alarms.

YES

Replace the analogic pressure switch and restart the diagnostic cycle to check for further alarms. Does the appliance display the alarm code again?

YES

Replace the main circuit board and restart the diagnostic cycle to check for further alarms.

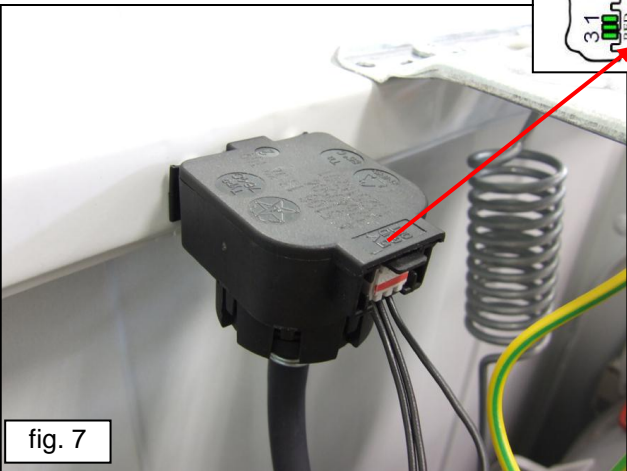
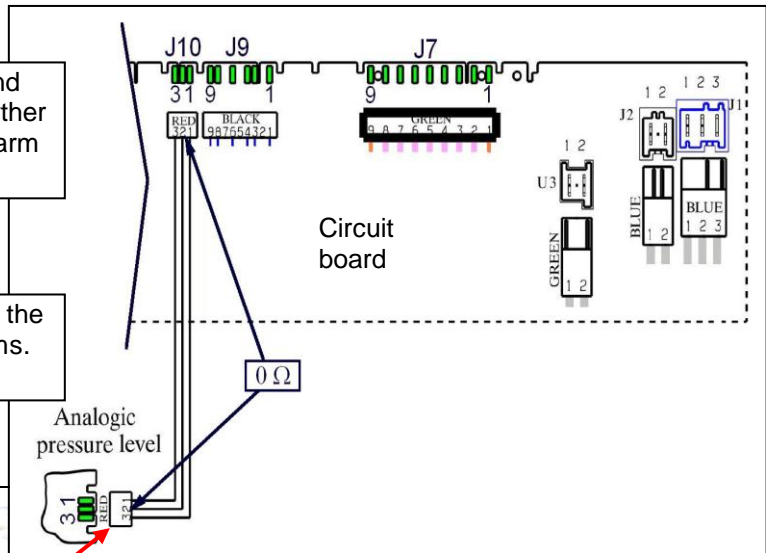

If there are burn marks on electronic board, see page 94

E32	<p>E32: The analogic pressure switch is giving an error during the calibration phase</p> <p>(At the beginning of each cycle the appliance drain to empty the tub and create a 0 level to verify the calibration of the analogic pressure switch)</p>	E32
------------	---	------------

Checks to perform: *Check that all the connectors are inserted correctly*

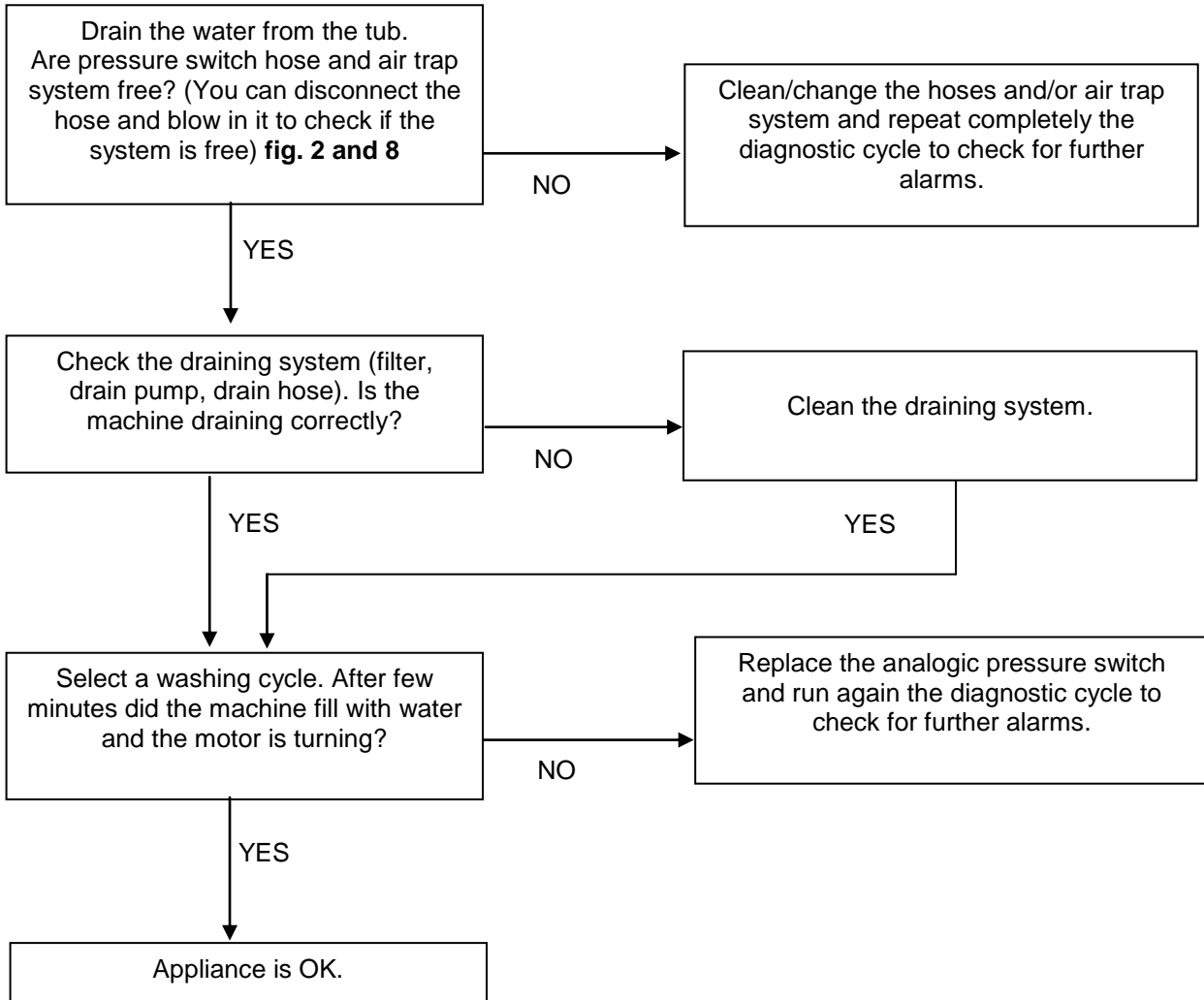

If there are traces of burning on the circuit board, refer to page 94

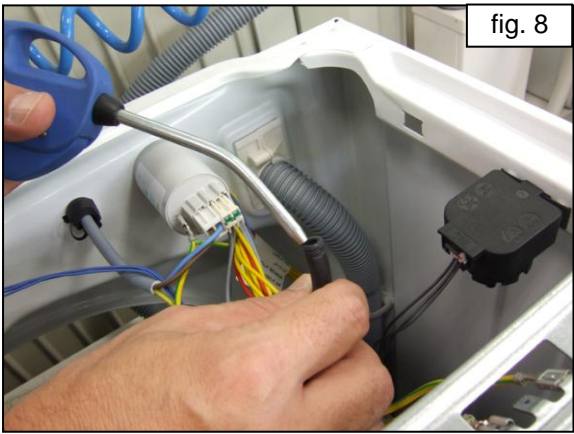
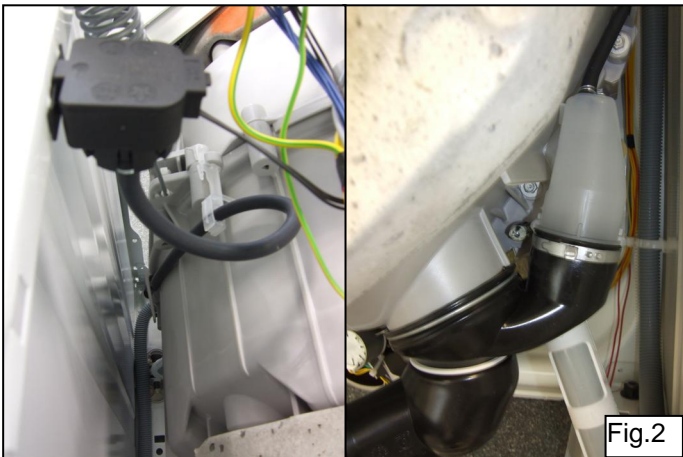

E35	E35: Water level too high	E35
	The electronic board measures a water level from analogic pressure switch higher then 300 mm for more then 15 seconds.	

Checks to perform: *Check that all the connectors are inserted correctly*

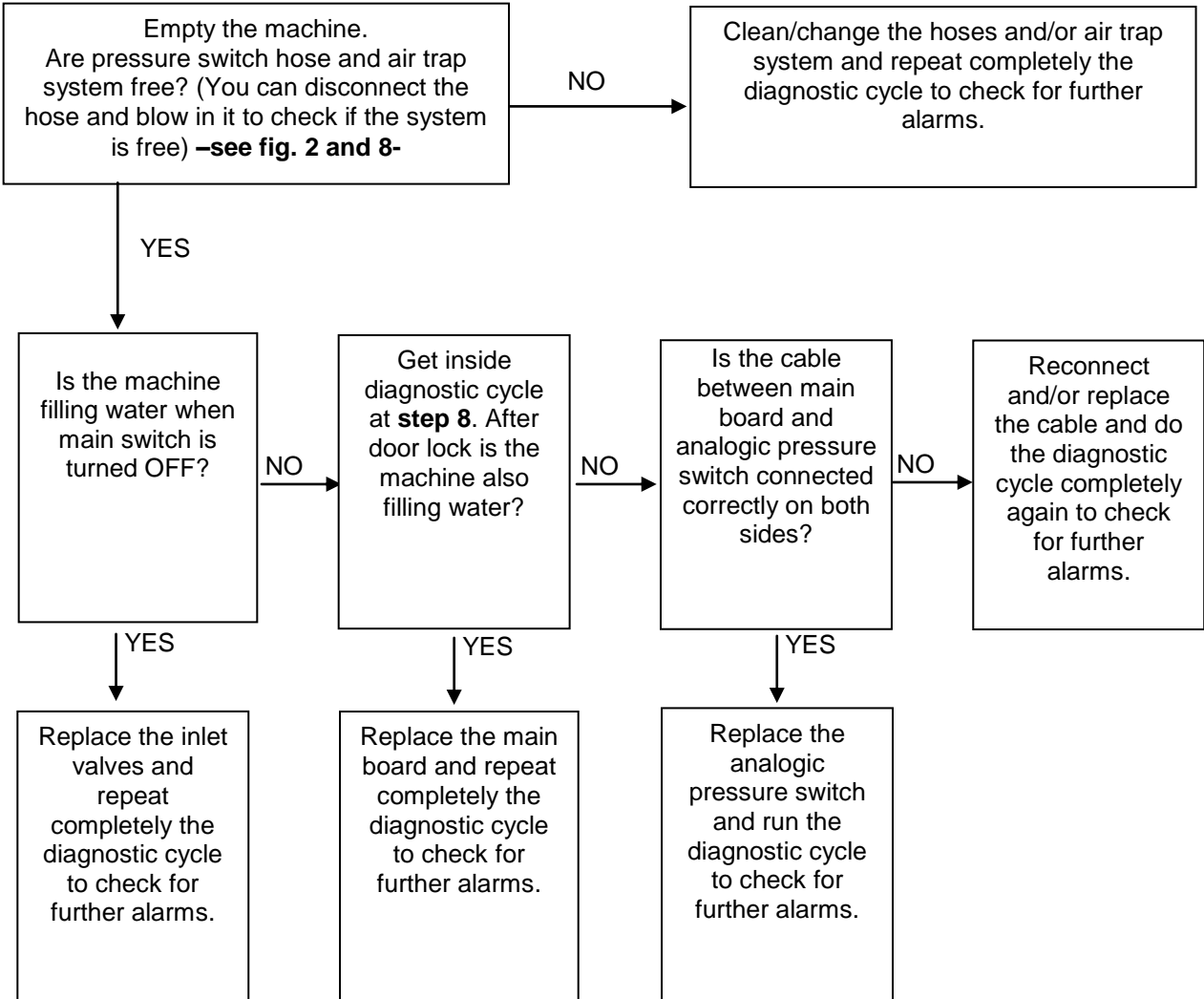

If there are traces of burning on the circuit board, refer to page 94

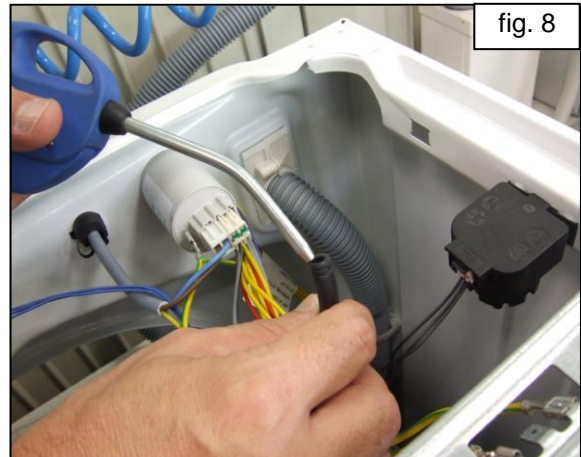
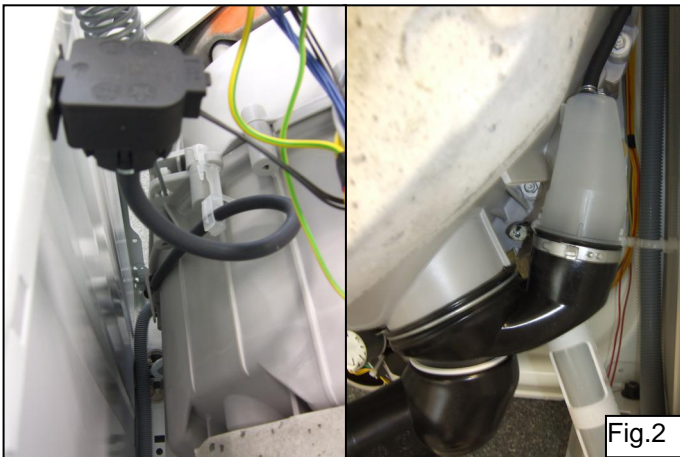

E38	E38: Pressure chamber blocked	E38
	The analogic pressure switch is not able to measure any variation of the water level for at least 30-sec. during drum movement.	

Checks to perform: *Check that all the connectors are inserted correctly*

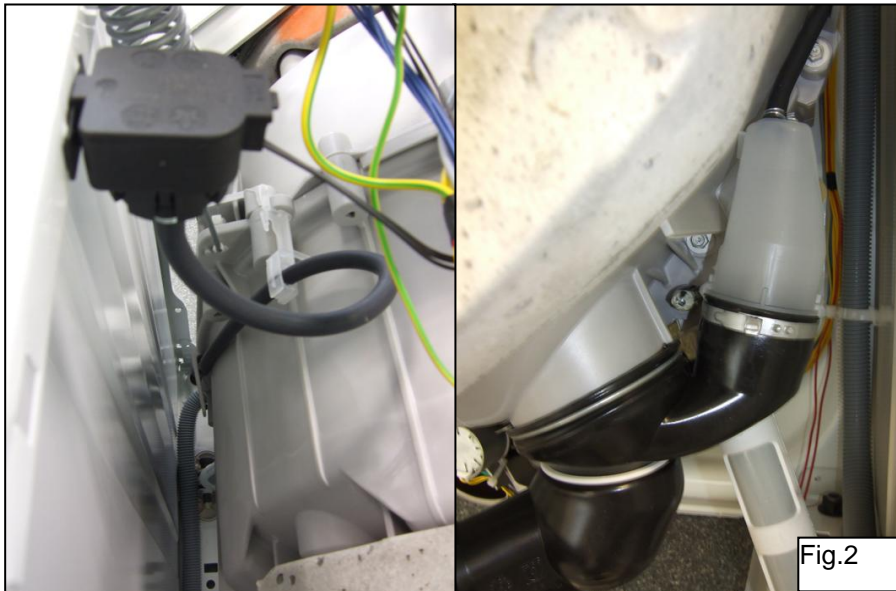
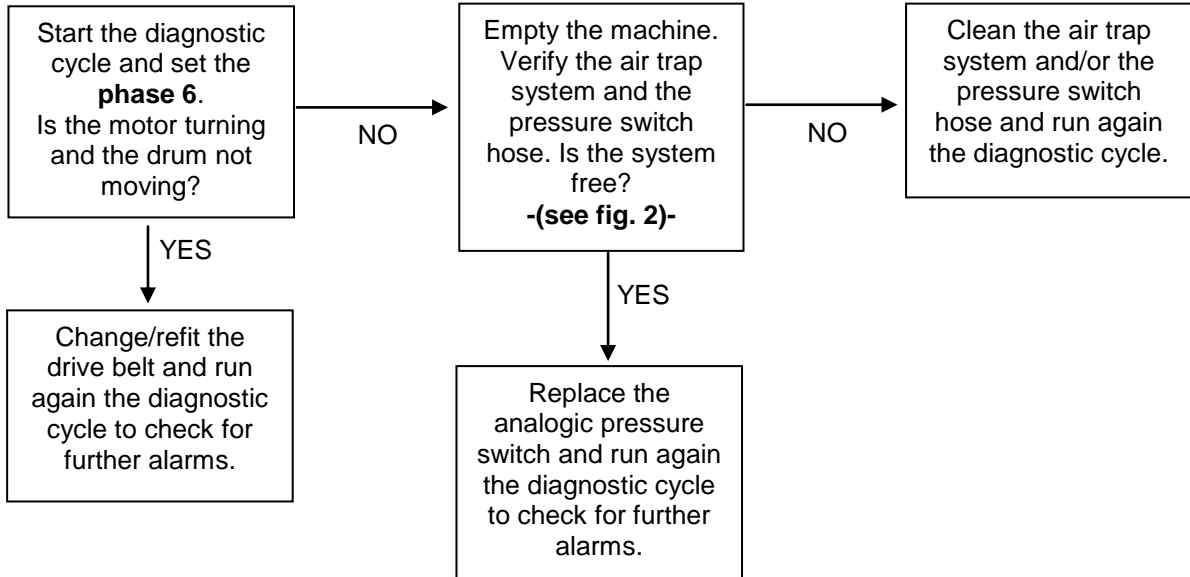

E3A

E3A: Problems with “Sensing” circuit of the heating element relay

E3A

Checks to perform: Check that all the connectors are inserted correctly

Replace the circuit board and run the diagnostic cycle again to check for further alarms.

E41	E41: Door open (3-contact device)	E41
	Maximum time exceeded (PTC = 15 seconds)	

Checks to perform: *Check that all the connectors are inserted correctly*

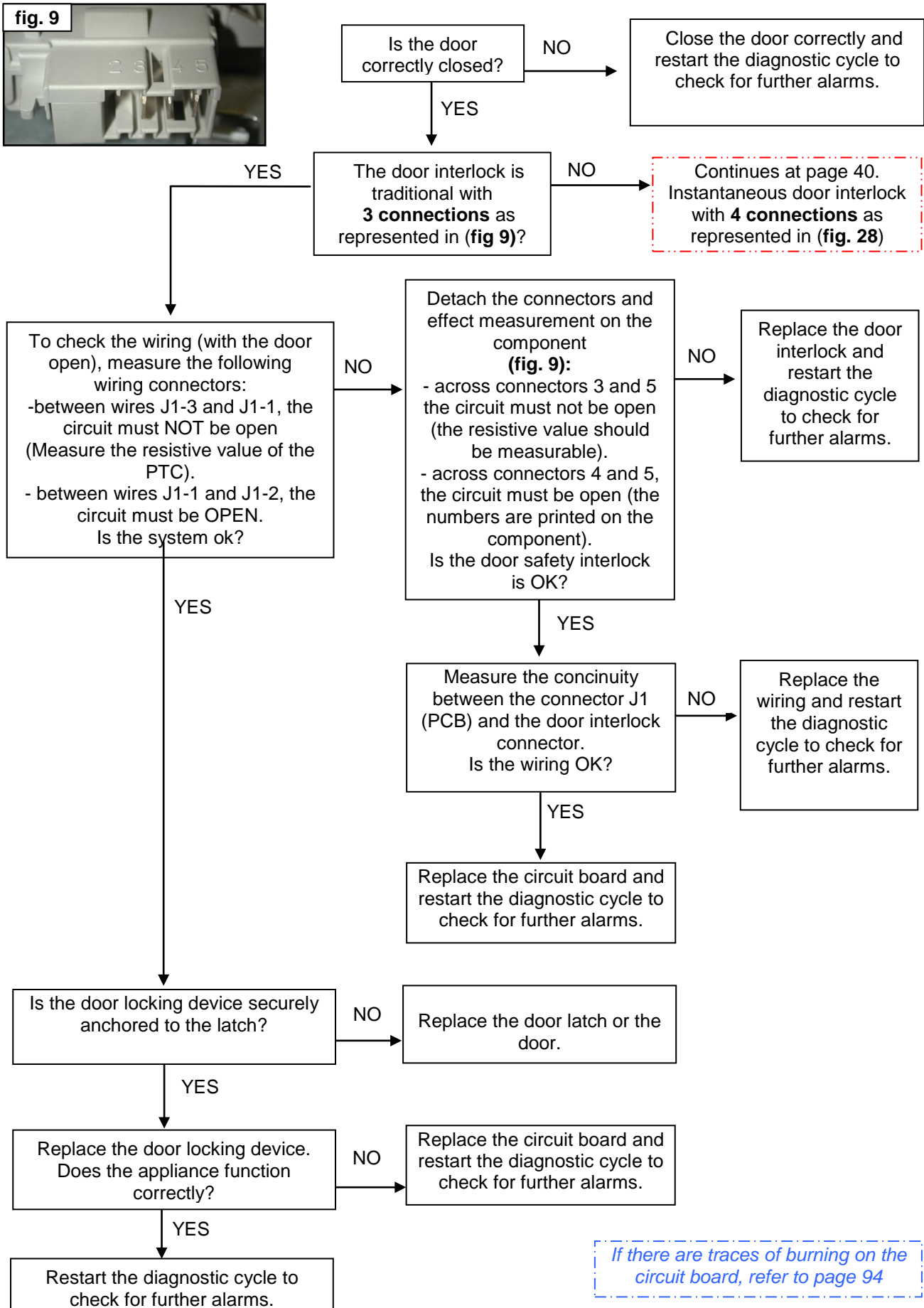
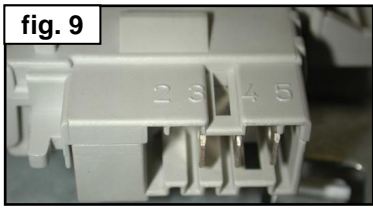

If there are traces of burning on the circuit board, refer to page 94

E41 (3-contact device)

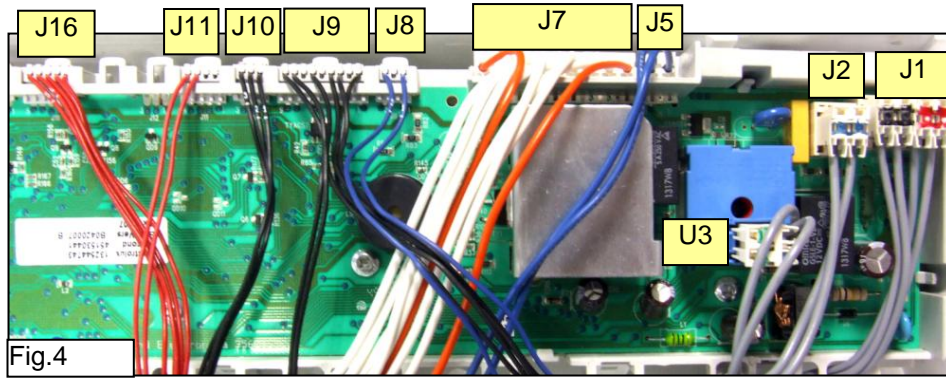
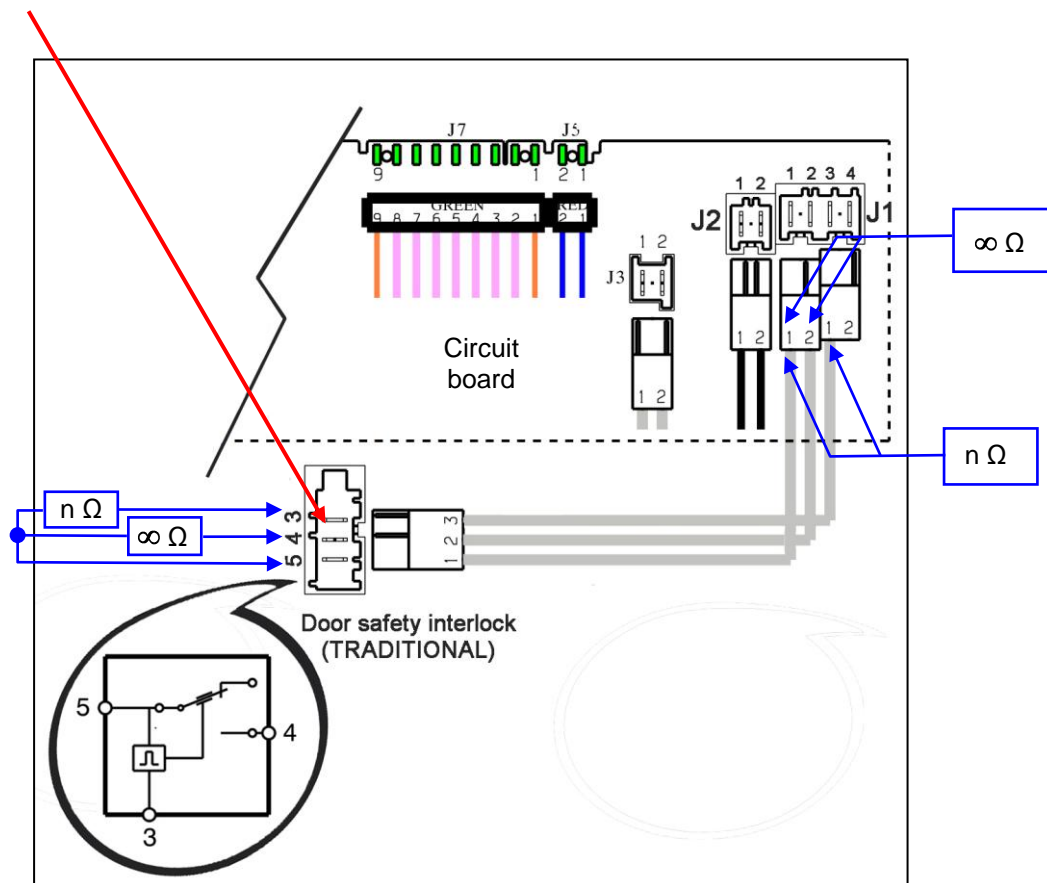

Fig.4

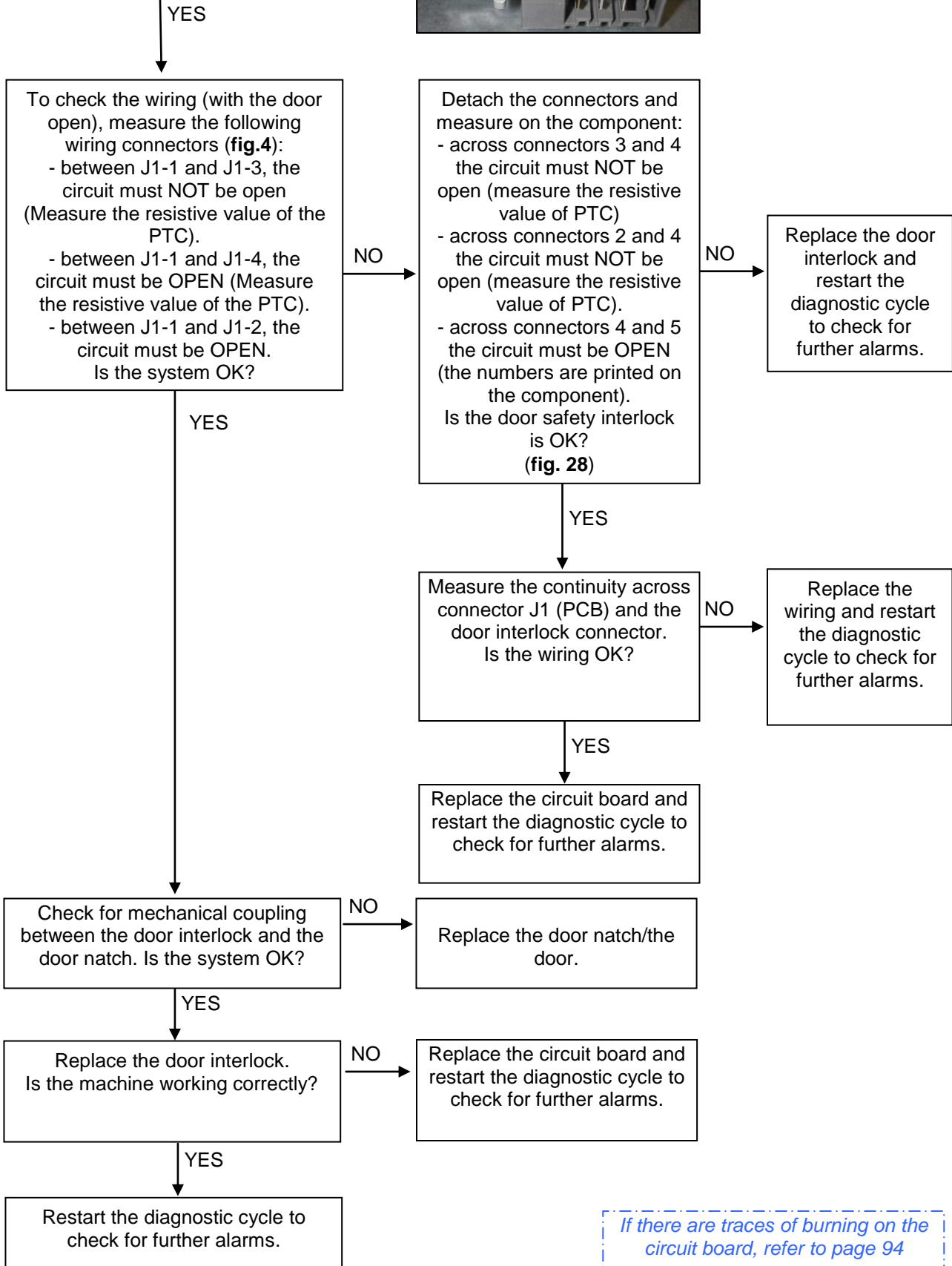
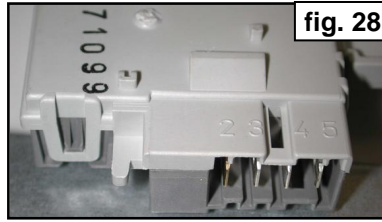

fig. 9



If there are traces of burning on the circuit board, refer to page 94

Instantaneous door interlock with **4 connections.**
- fig 28 -



If there are traces of burning on the circuit board, refer to page 94

E41 (4-contact device)

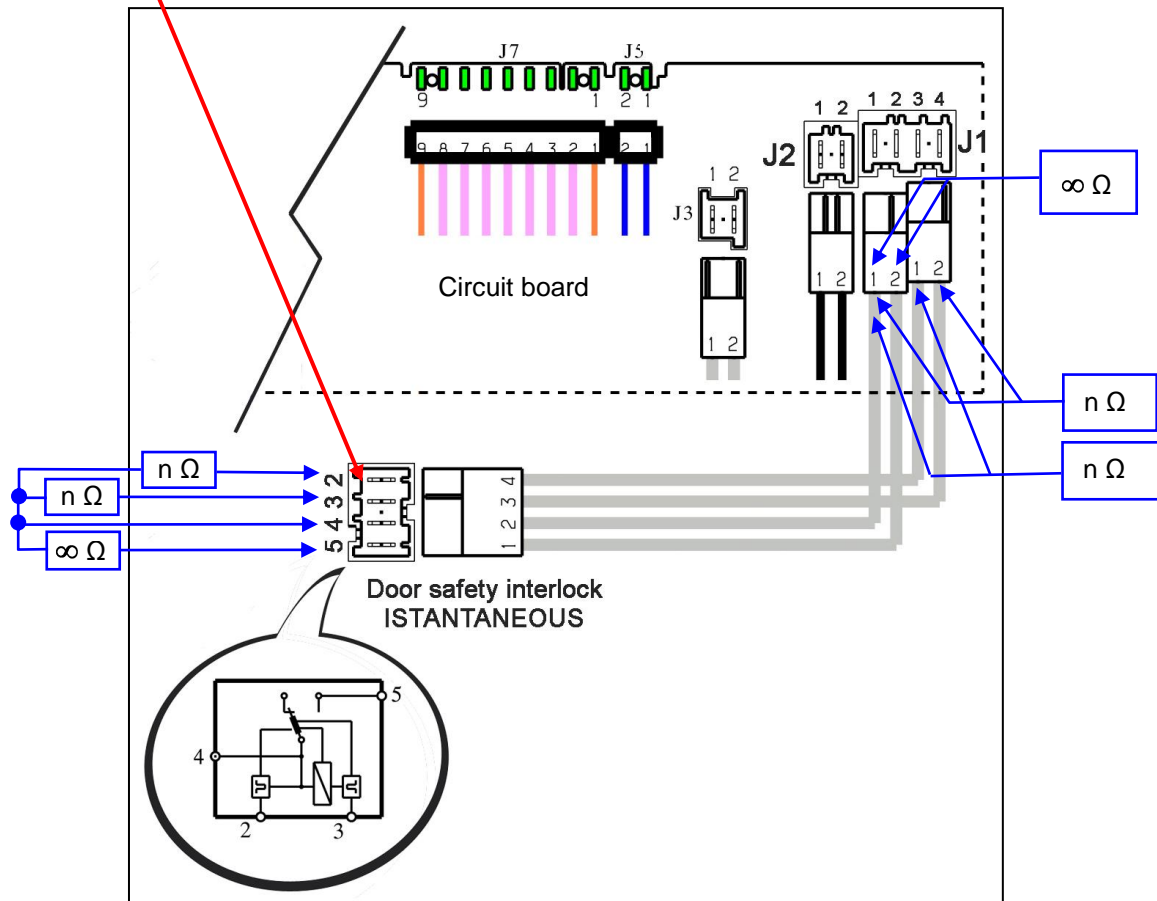
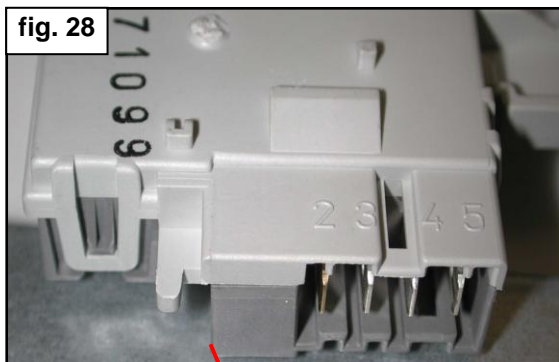
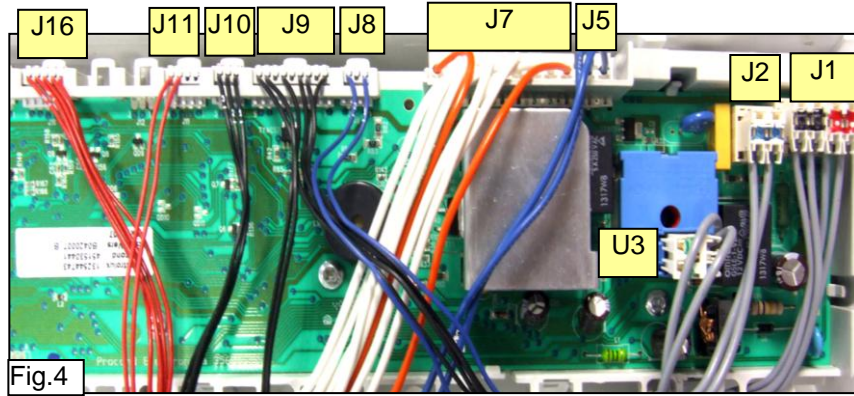

Checks to perform: *Check that all the connectors are inserted correctly*

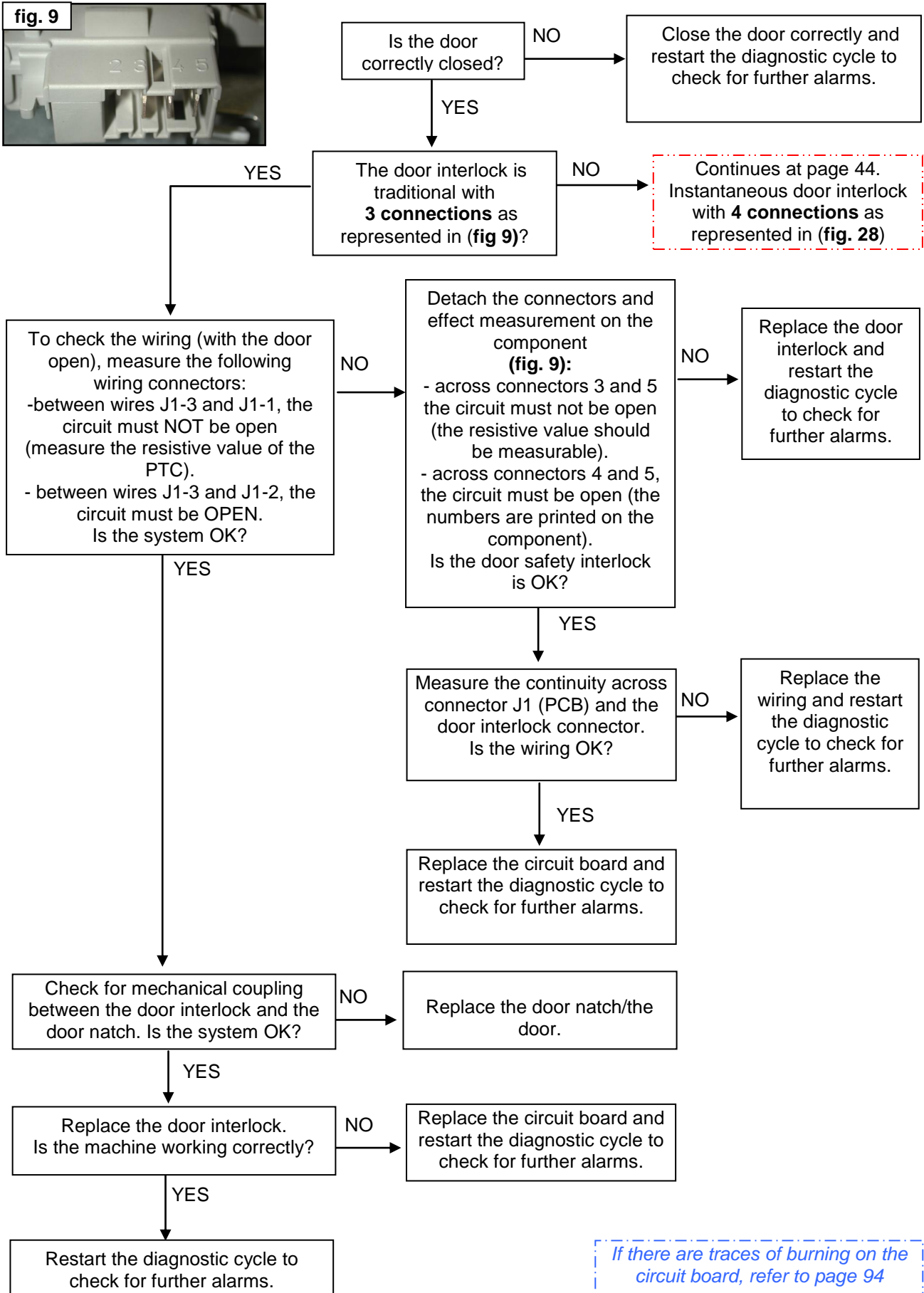
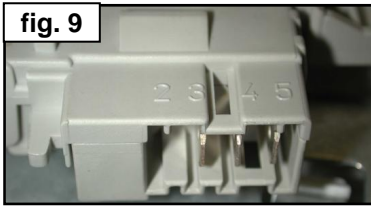

If there are traces of burning on the circuit board, refer to page 94

E42 (3-contact device)

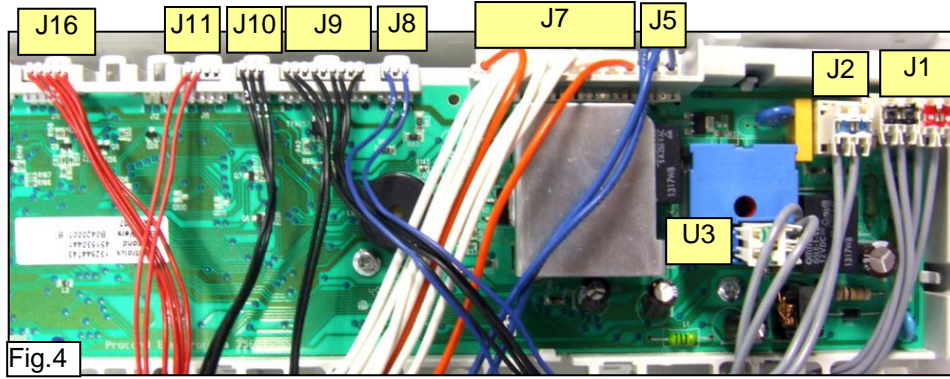
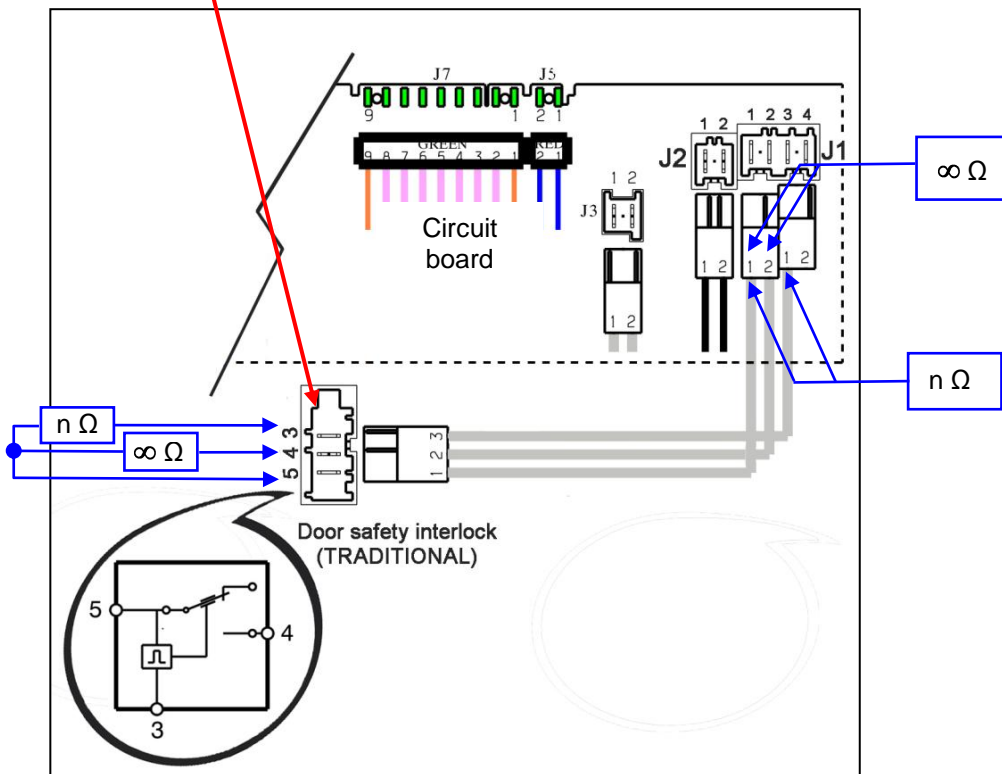

Fig.4



fig. 9



If there are traces of burning on the circuit board, refer to page 94

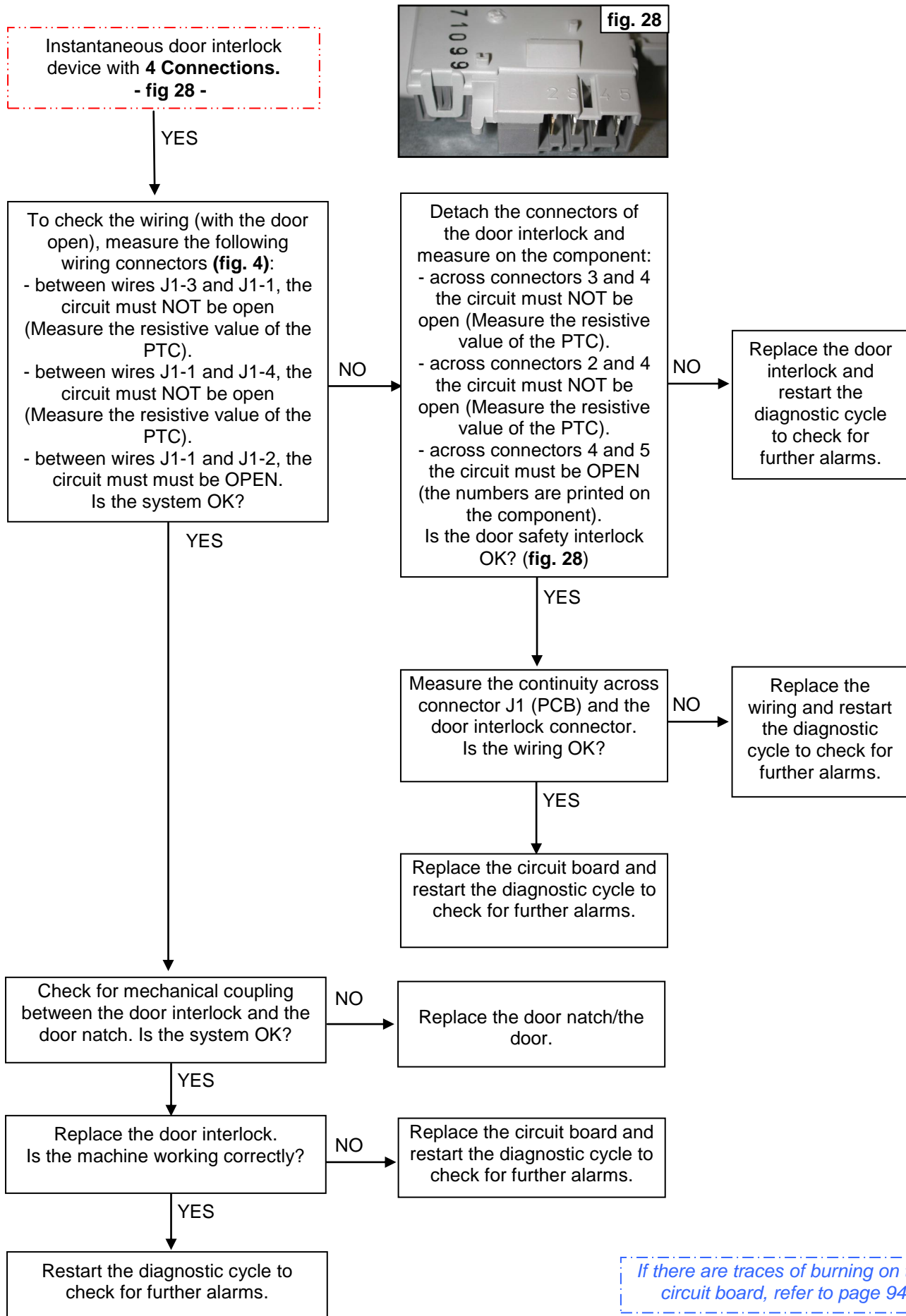

E42 (4-contact device)

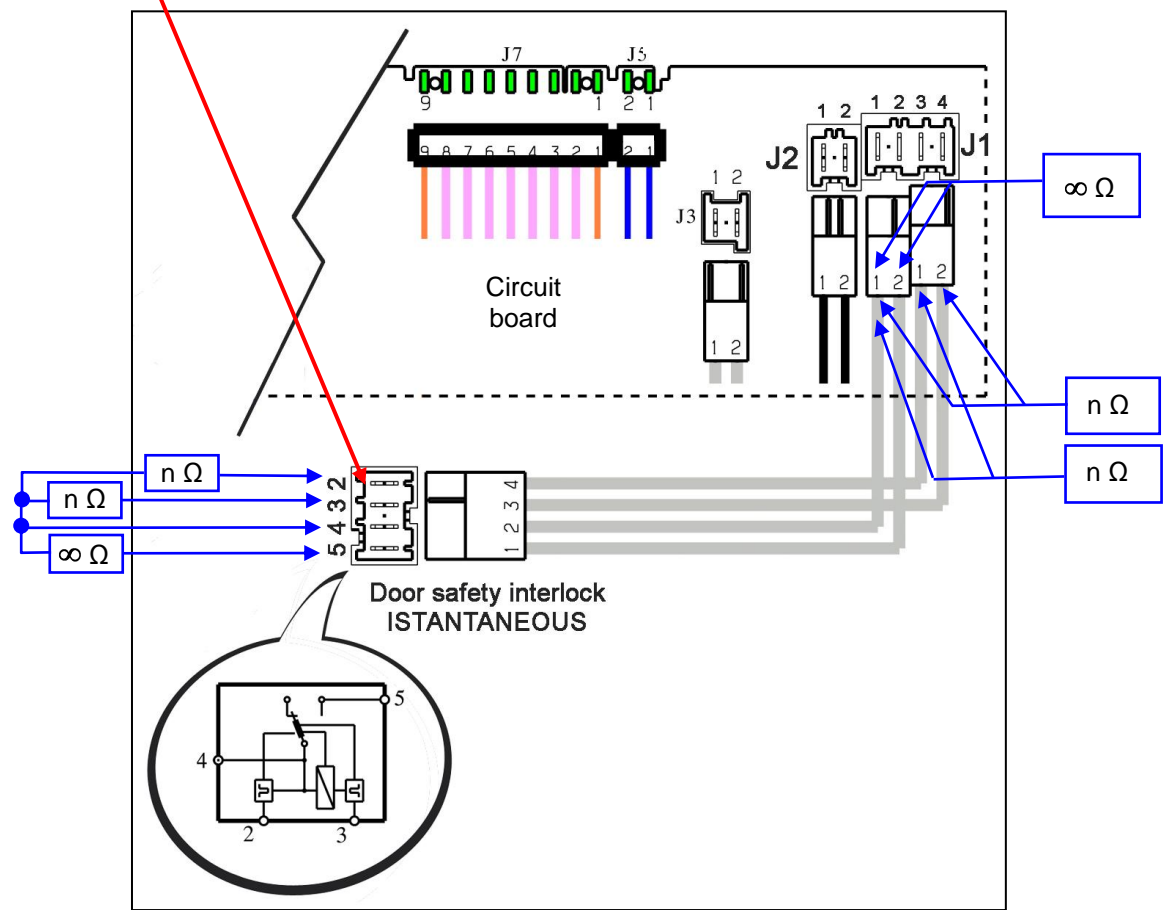
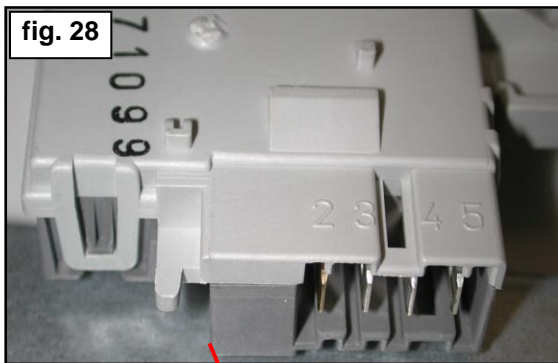
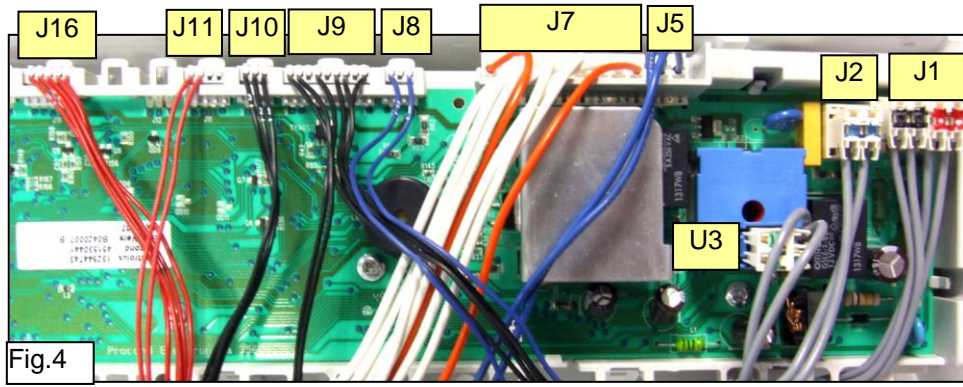

Checks to perform: Check that all the connectors are inserted correctly

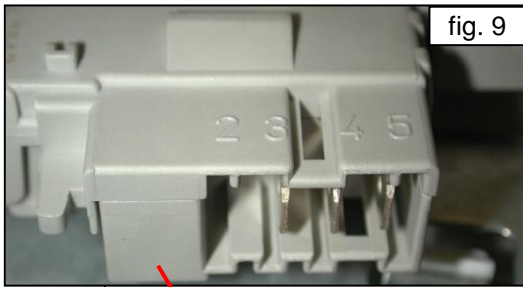
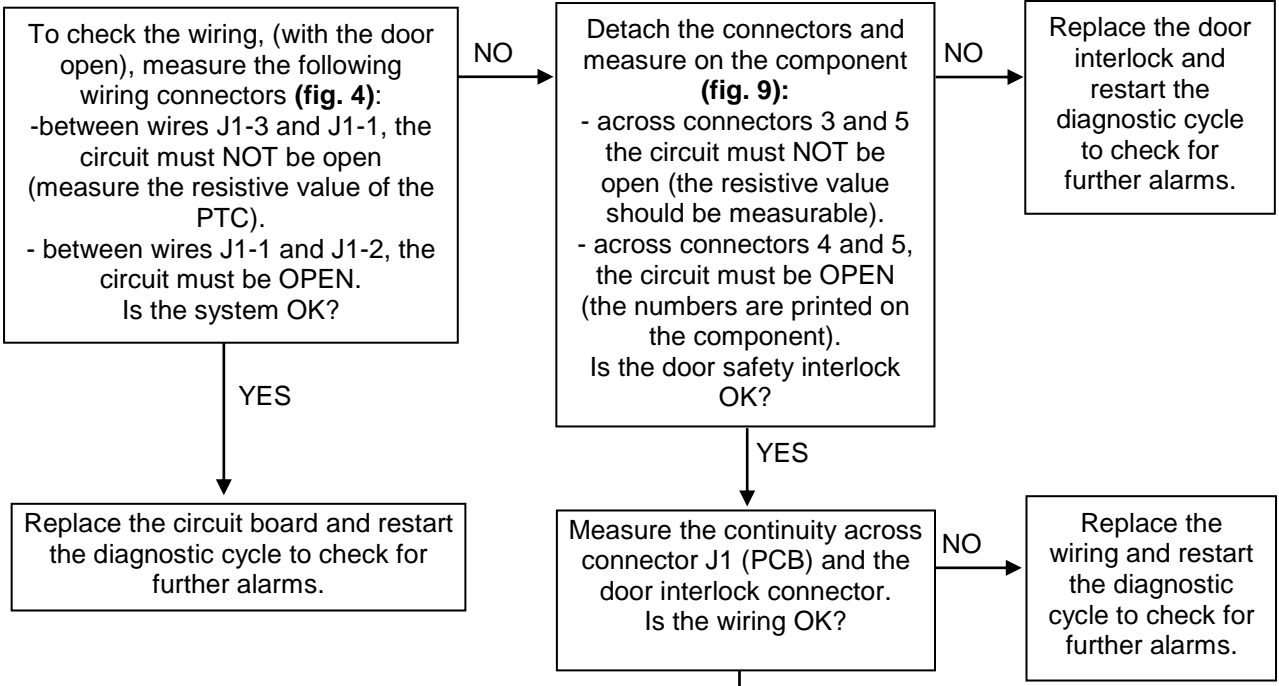
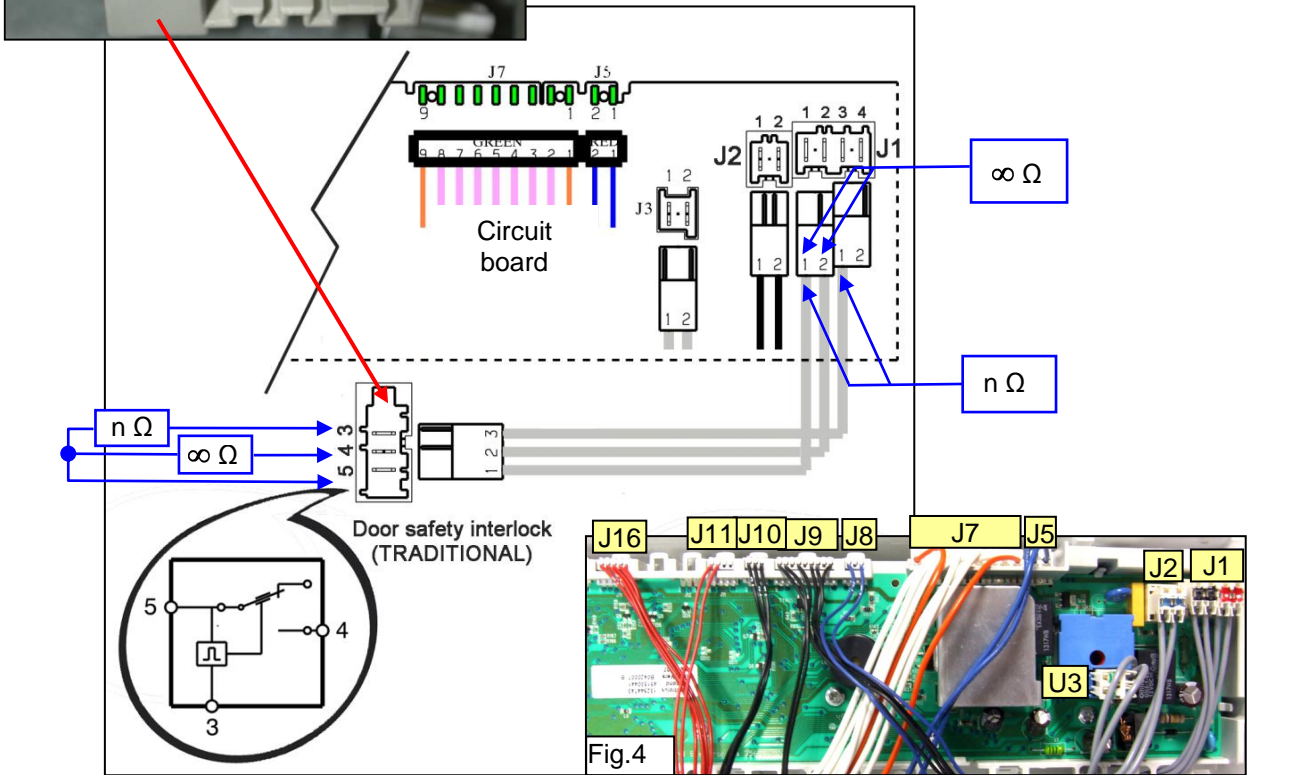
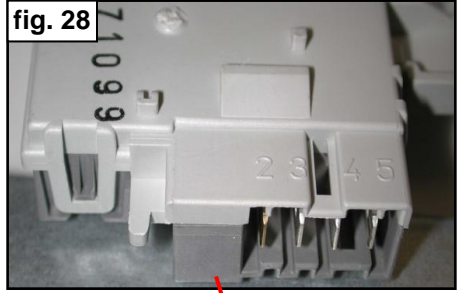
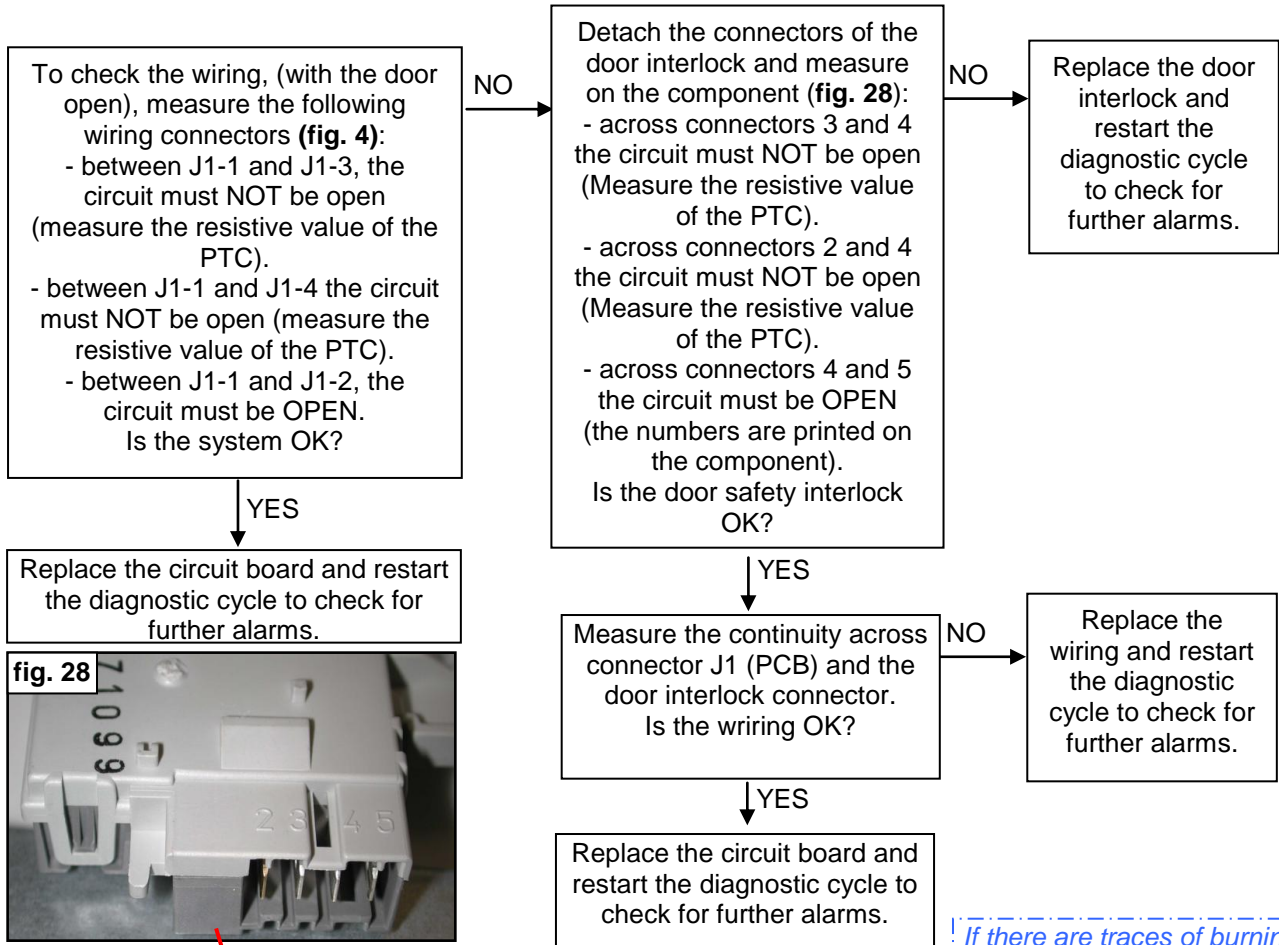

fig. 9



Checks to perform: Check that all the connectors are inserted correctly



If there are traces of burning on the circuit board, refer to page 94

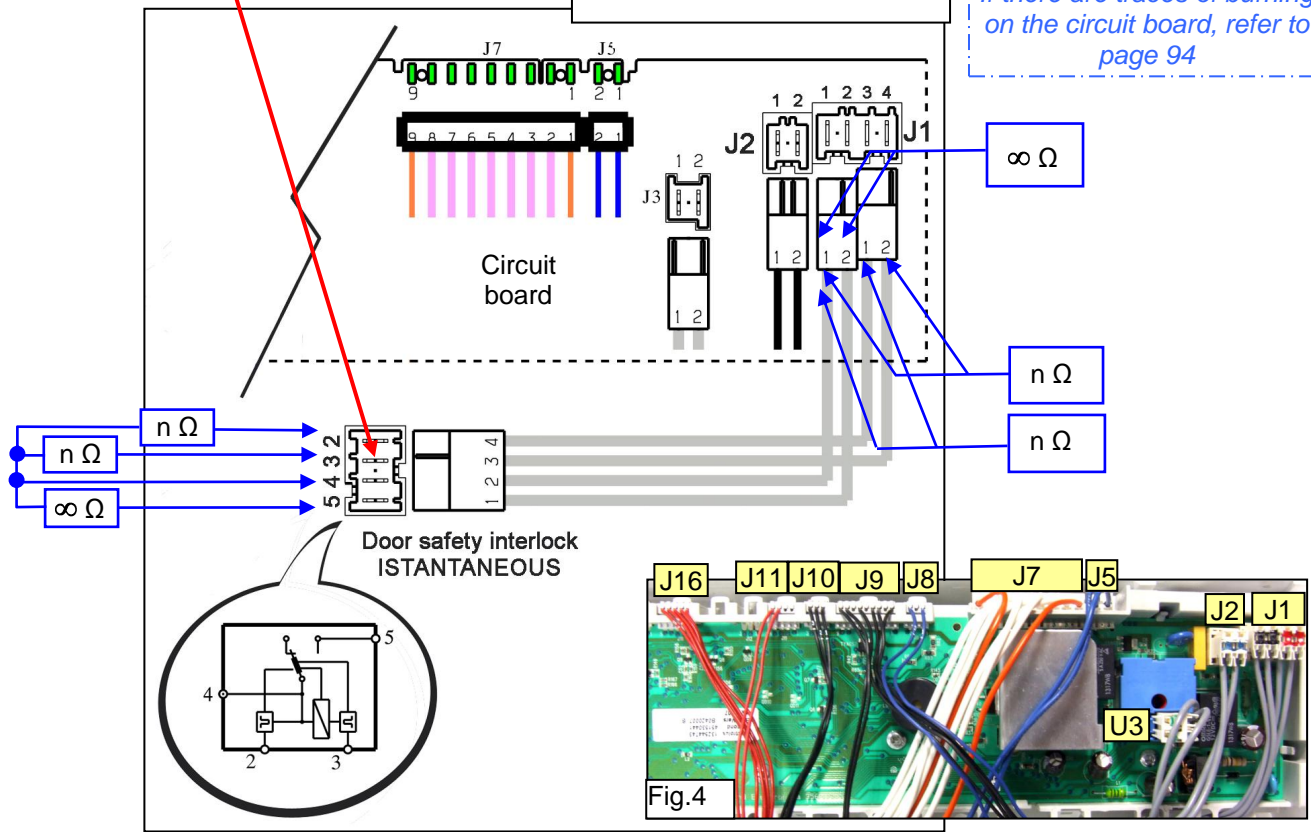

E44	E44: Door closure “sensing” circuit faulty	E44
------------	---	------------

Checks to perform: Check that all the connectors are inserted correctly

Replace the circuit board and restart the diagnostic cycle to check for further alarms.

E45	E45: Problems with the “sensing” circuit of the triac that actions the door interlock	E45
------------	--	------------

Checks to perform: Check that all the connectors are inserted correctly

Replace the circuit board and restart the diagnostic cycle to check for further alarms.

If there are traces of burning on the circuit board, refer to page 94

E51	E51: Motor power triac short-circuited	E51
	Intervention of the safety system for short-circuiting of the triac (after 5 attempts during the cycle, immediately if detected at the start or during diagnostics)	

Checks to perform: Check that all the connectors are inserted correctly

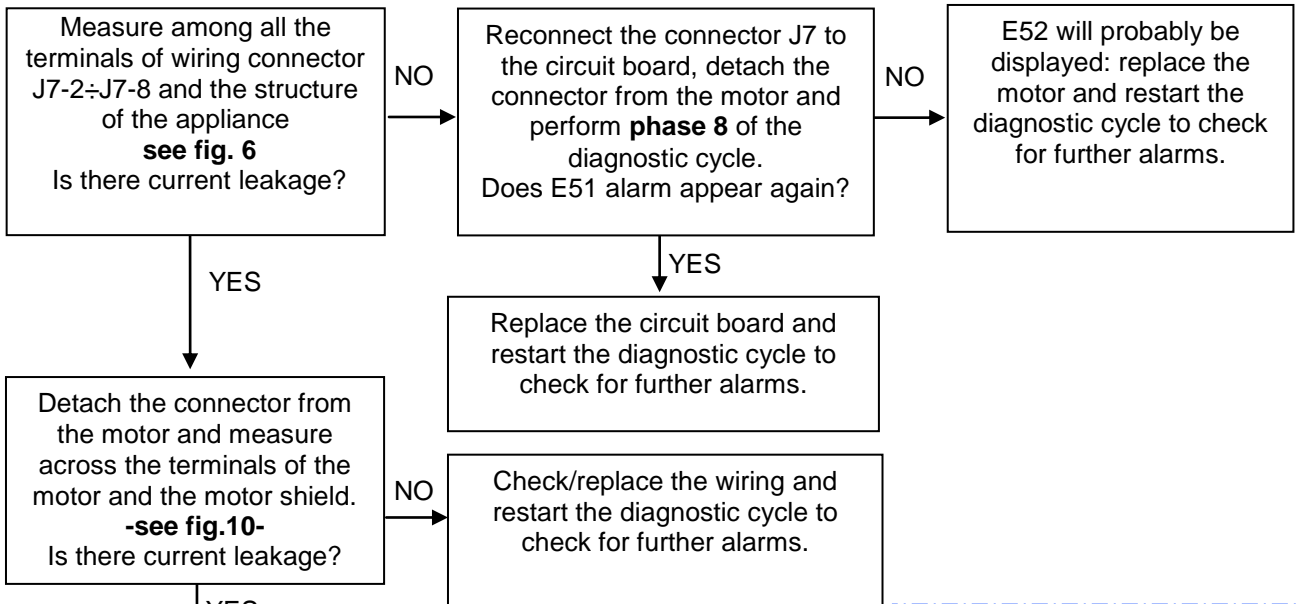

If there are traces of burning on the circuit board, refer to page 94

Replace the motor and restart the diagnostic cycle to check for further alarms.

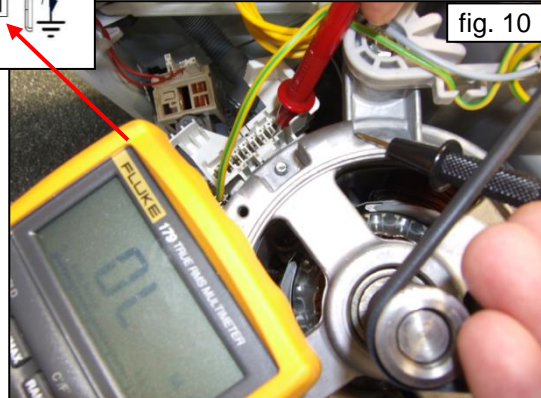
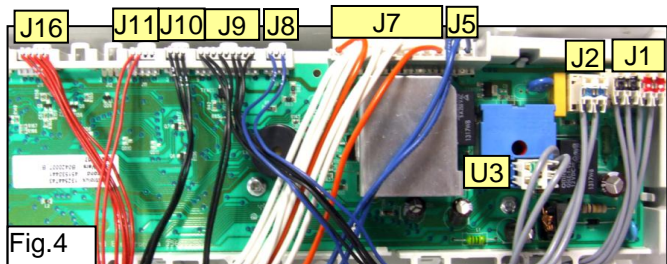
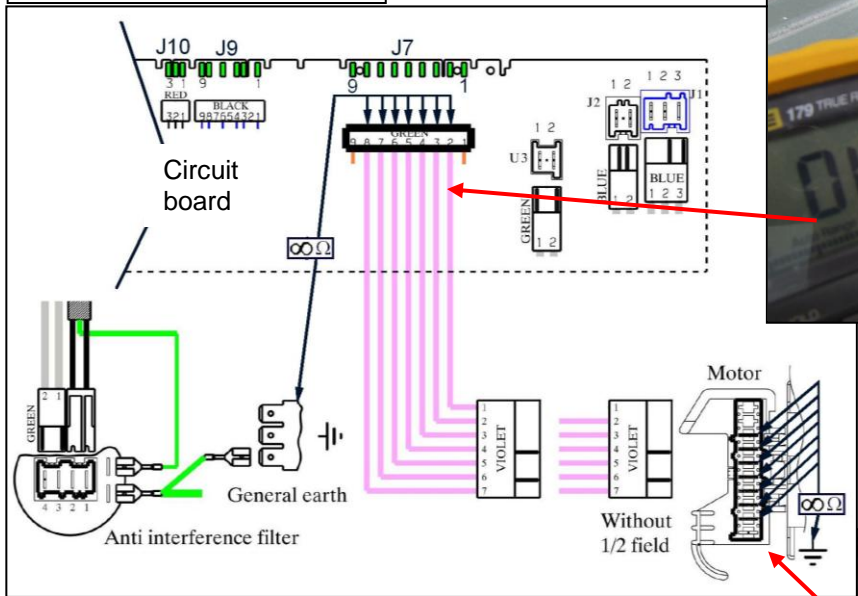

E52	E52: No signal from the motor tachometric generator (first part)	E52
	Cycle blocked after 5 attempts during the cycle or immediately if detected at the start or during diagnostics.	

Checks to perform:

Check that all the connectors are inserted correctly

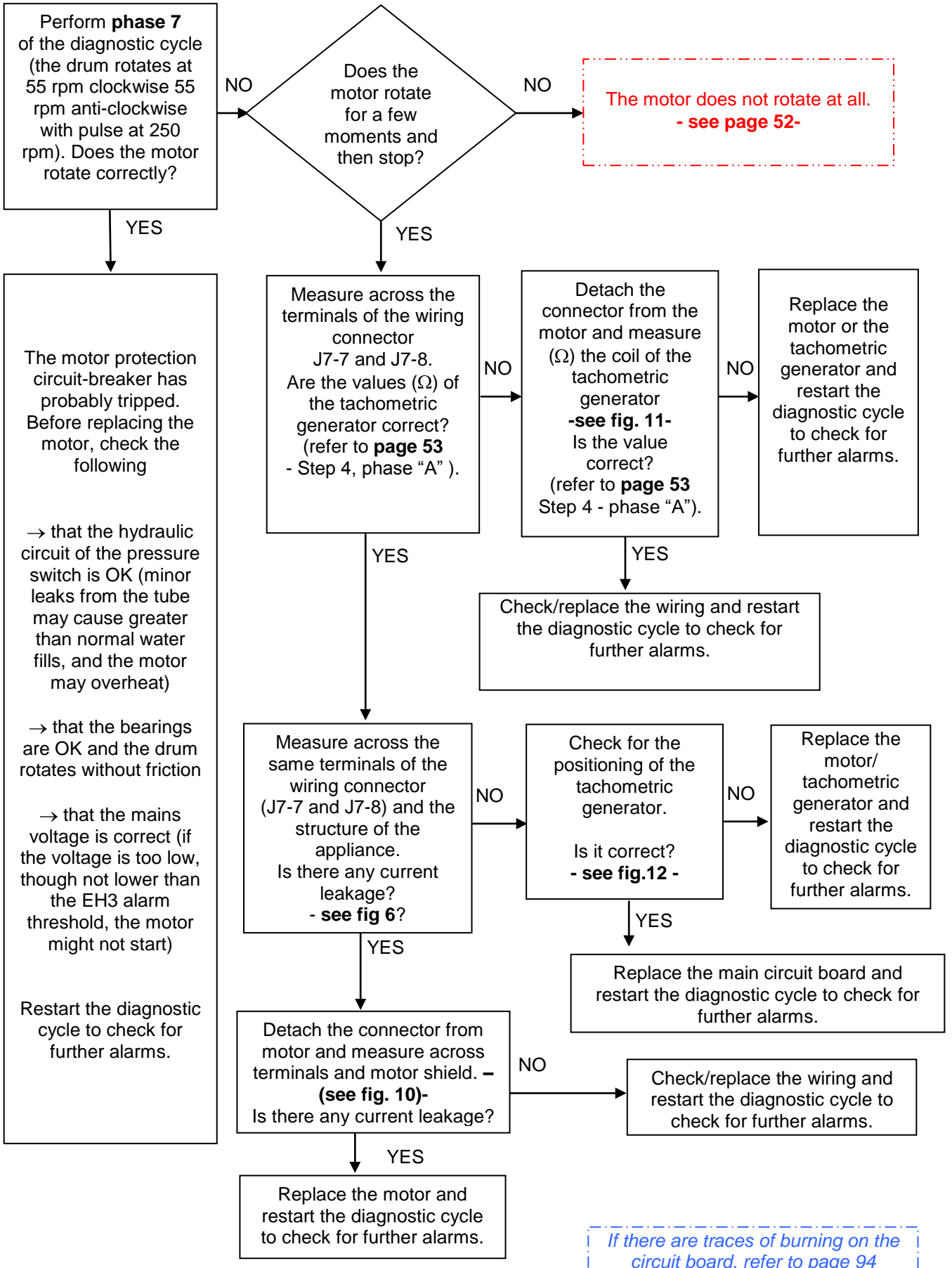

E52a

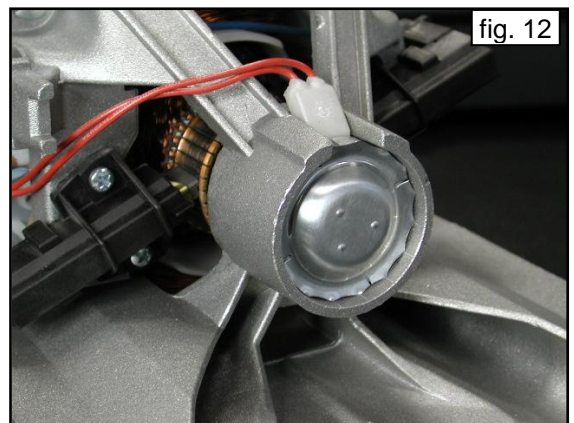
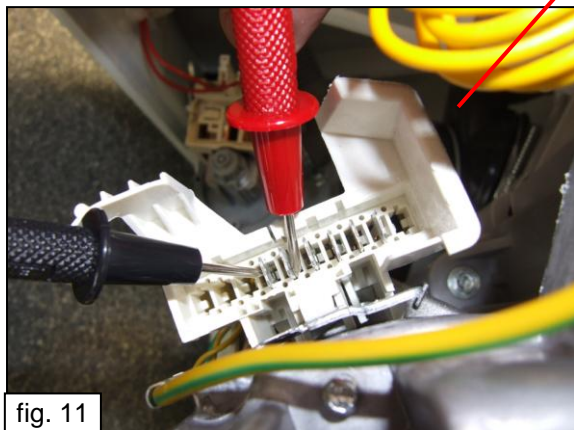
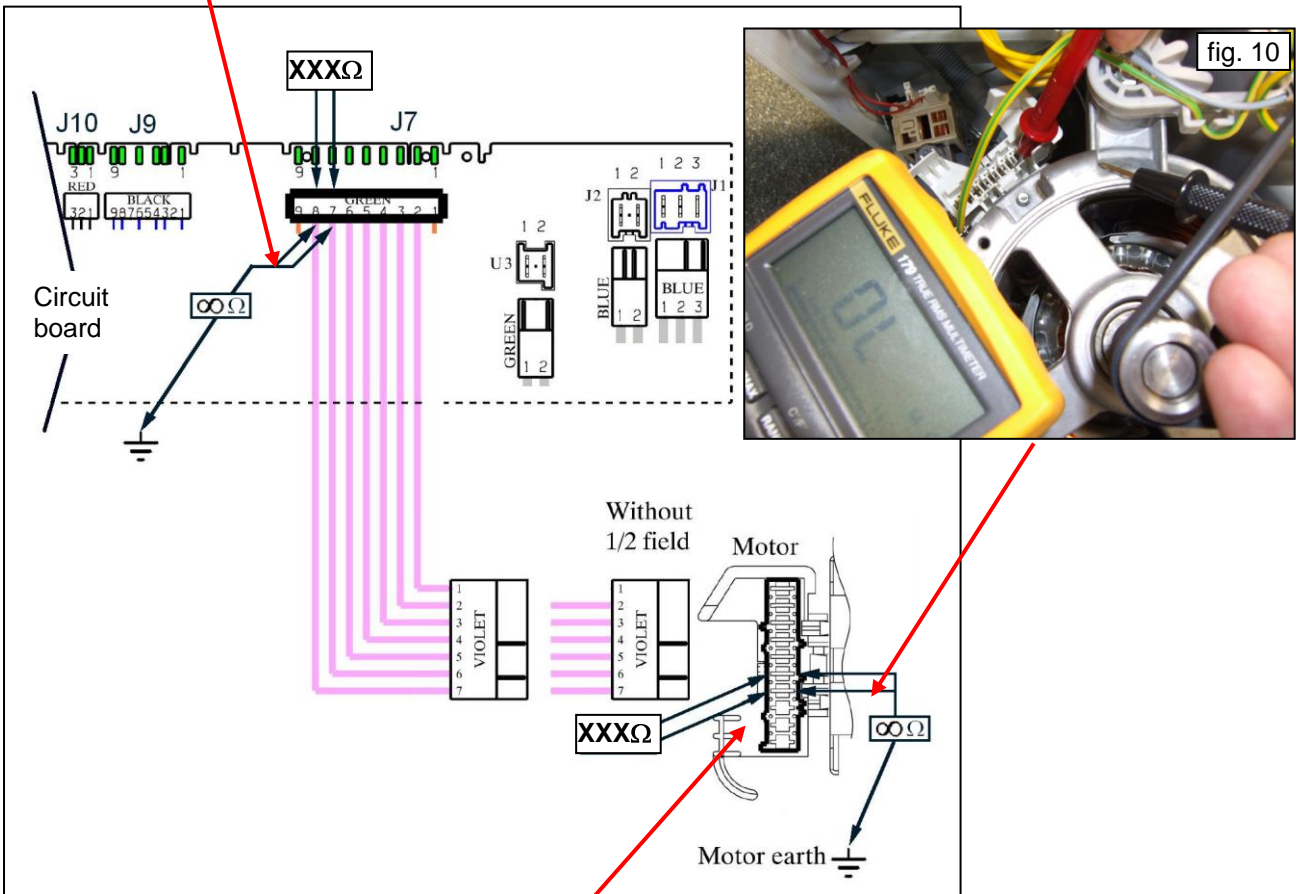
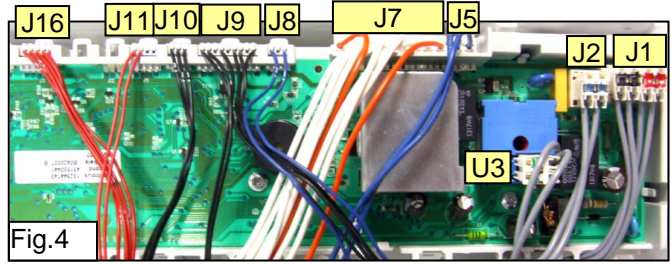

E52	E52: No signal from the motor tachometric generator (second part) Cycle blocked after 5 attempts during the cycle or immediately if detected at the start or during diagnostics.	E52
------------	--	------------

Checks to perform: Check that all the connectors are inserted correctly

The motor does not rotate at all.

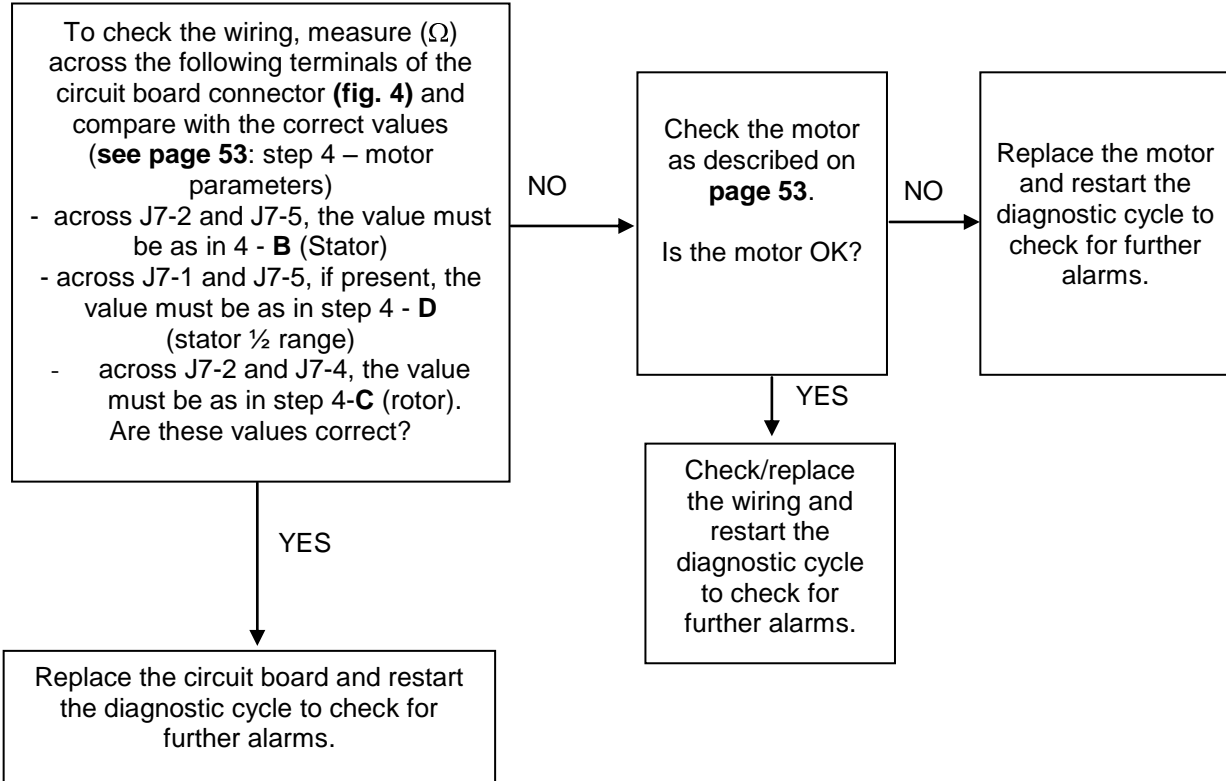

If there are traces of burning on the circuit board, refer to page 94

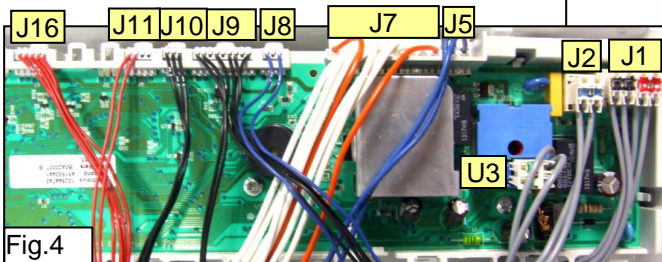
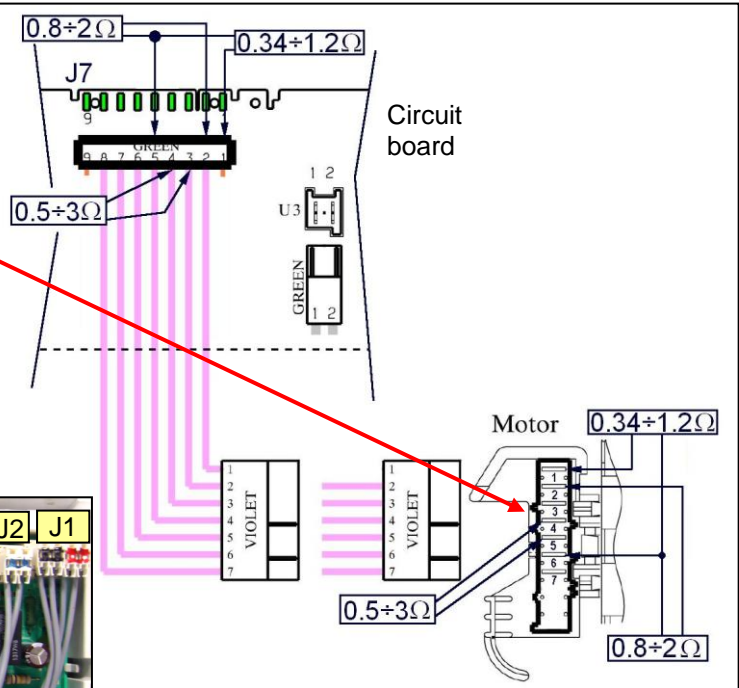
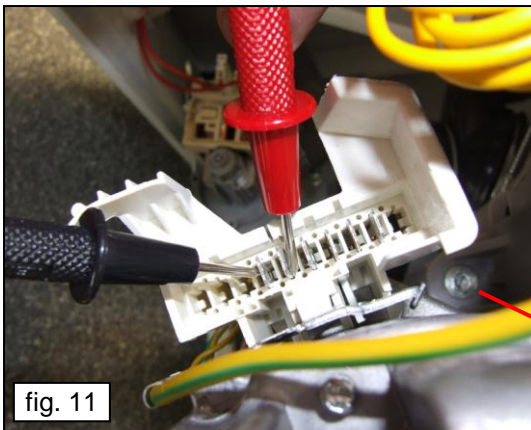

Procedure for checking the commutator motors

- 1) Check the connector blocks (wiring) and check for detached or bent terminals.
- 2) Check for traces, residue or deposits of water or detergent on the motor and identify the source.
- 3) Check for windings or other parts that may be grounded or poorly insulated. Use a tester with a minimum scale of 40 M Ω : between each terminal and the casing, this should read ∞ (fig. 10).
- 4) Check each winding against the values shown in the table below (fig. 11).

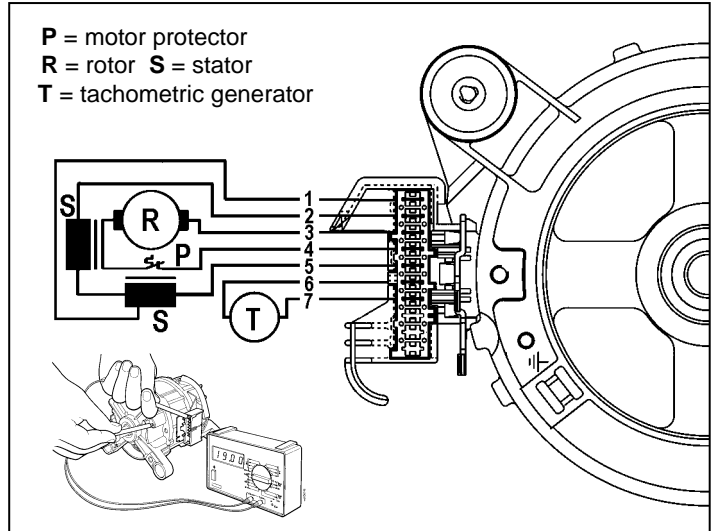

	TERMINALS ON MOTOR TERMINAL BLOCK	CHECKS:	MOTORS				
			C.E.SET. []	ACC (FHP)	ACC (SOLE)	BSH	ECM
A	6-7	Winding of tachymetric generator	63÷74	125÷145	468÷540 171÷197	14÷16	84÷98
B	2-5	Stator winding (full range)	1.0÷2.0	0.9÷3.2	0.8÷1.9	1.4÷1.9	1.3÷1.6
C	3-4	Rotor winding (overheating breaker)	1.6÷2.7	0.5÷3.0	1.4÷2.3	1.5÷1.9	1.8÷2.5
D	1-5	Stator winding (half range, presence of terminal 1)	0.34÷0.65	0.4÷1.2	0.4÷1.0	1.0÷1.2	0.6÷0.8

N.B.: When checking the rotor winding, the measurement must be effected over the entire surface, rotating the spindle very slowly and checking for short-circuits between visible plates. Also check the brushes for wear.

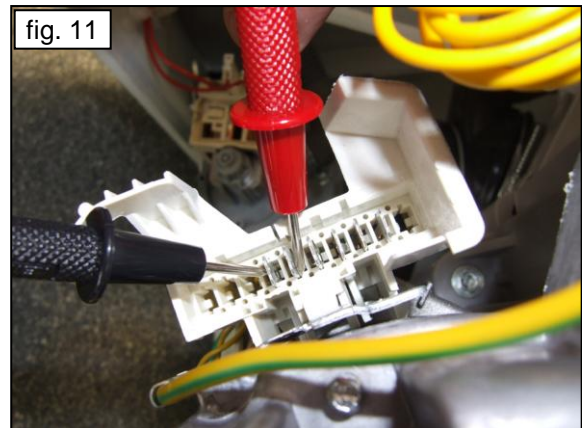
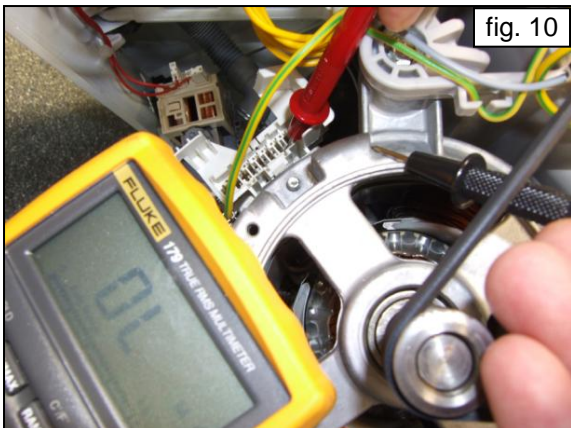

E53

E53: Problems with the "Sensing" circuit of the triac which powers the motor

E53

Checks to perform: Check that all the connectors are inserted correctly

Replace the circuit board and restart the diagnostic cycle to check for further alarms.

If there are traces of burning on the circuit board, refer to page 94

E54	E54: Motor relay contacts sticking	E54
	Voltage in the motor circuit even when the motor should be inoperative	

Checks to perform: *Check that all the connectors are inserted correctly*

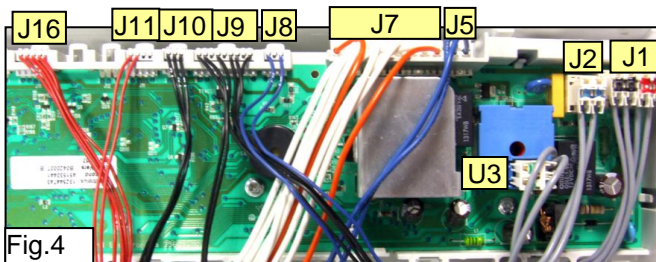
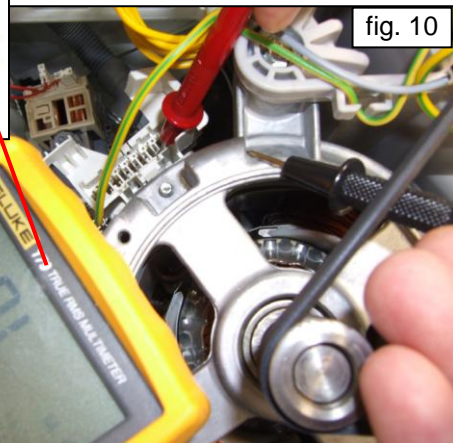
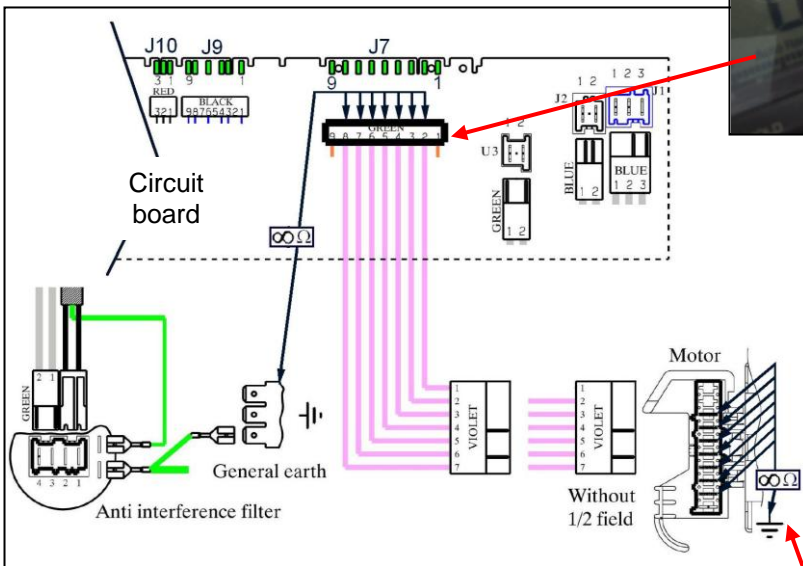
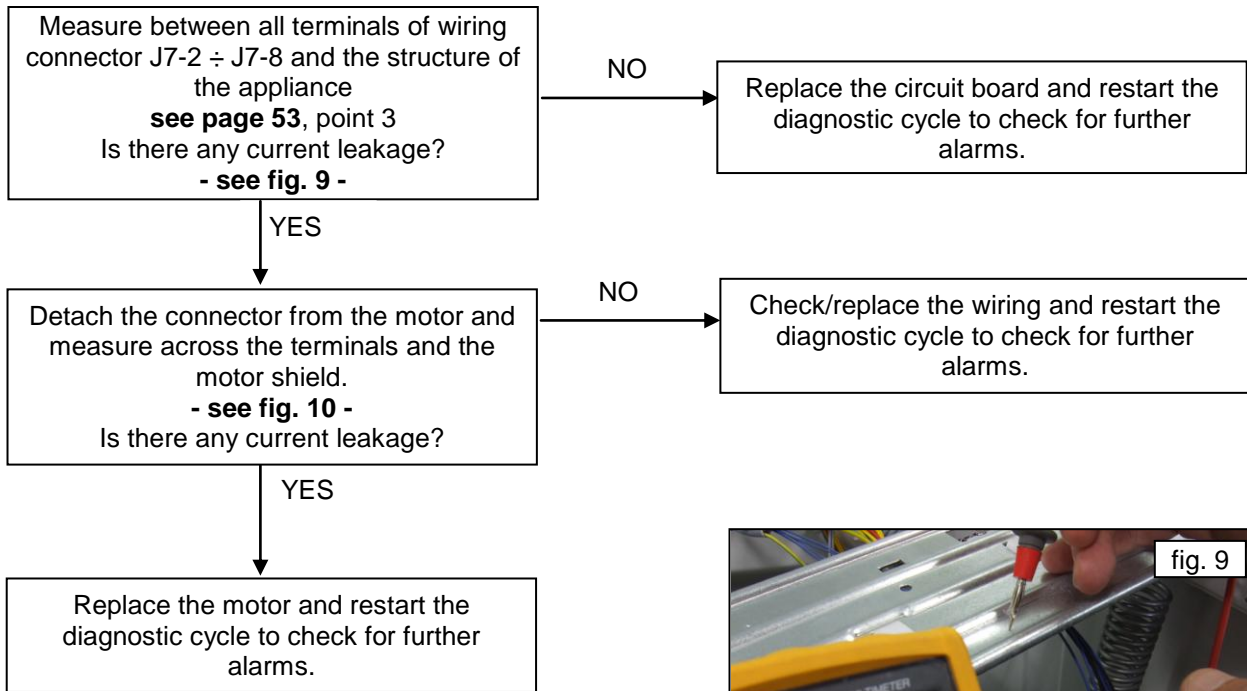

If there are traces of burning on the circuit board, refer to page 94

E61	E61: Insufficient heating during washing	E61
	Maximum heating time exceeded ☞ SOMETIMES THE ALARM CAN BE CAUSED BY THE POWER VOLTAGE TOO LOW!	

Checks to perform: Check that all the connectors are inserted correctly

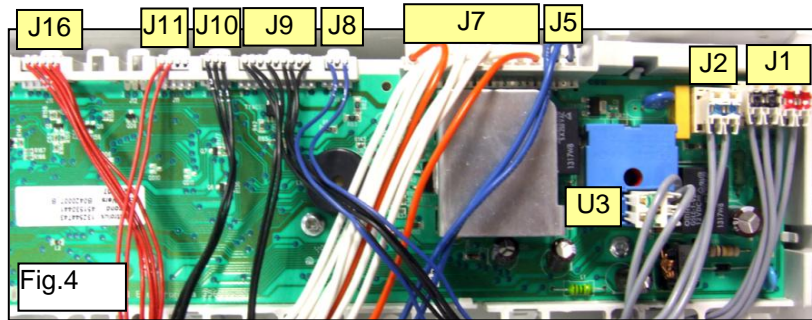
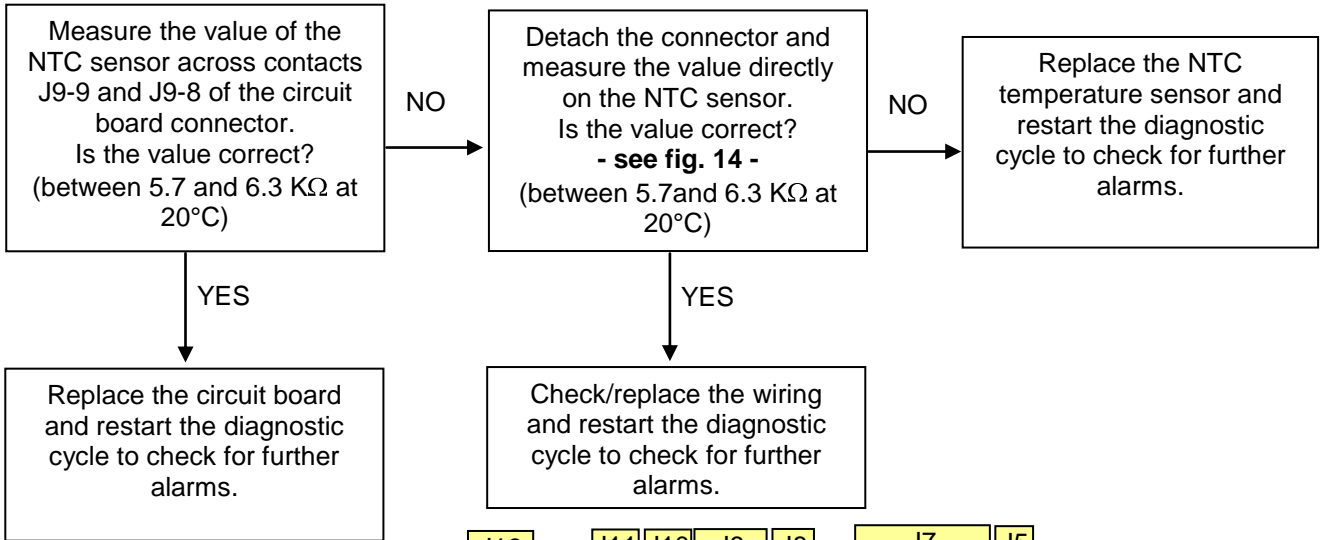

If there are traces of burning on the circuit board, refer to page 94

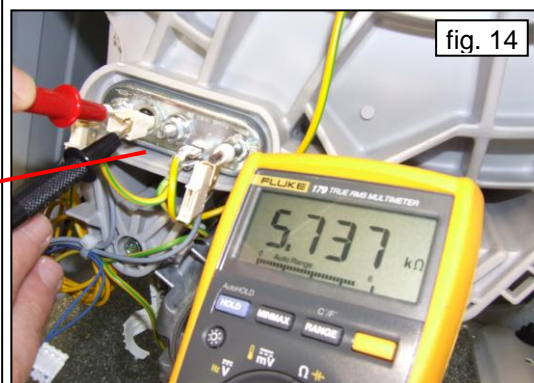
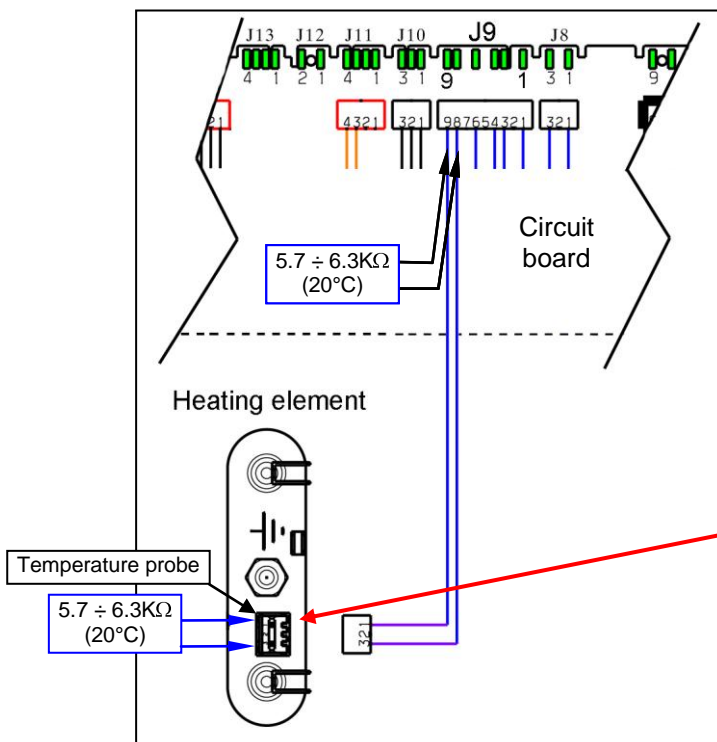

E62	E62: Overheating during washing (version WM)	E62
	The temperature of the NTC sensor exceeds 88°C for more than 5 minutes.	

Checks to perform: *Check that all the connectors are inserted correctly*

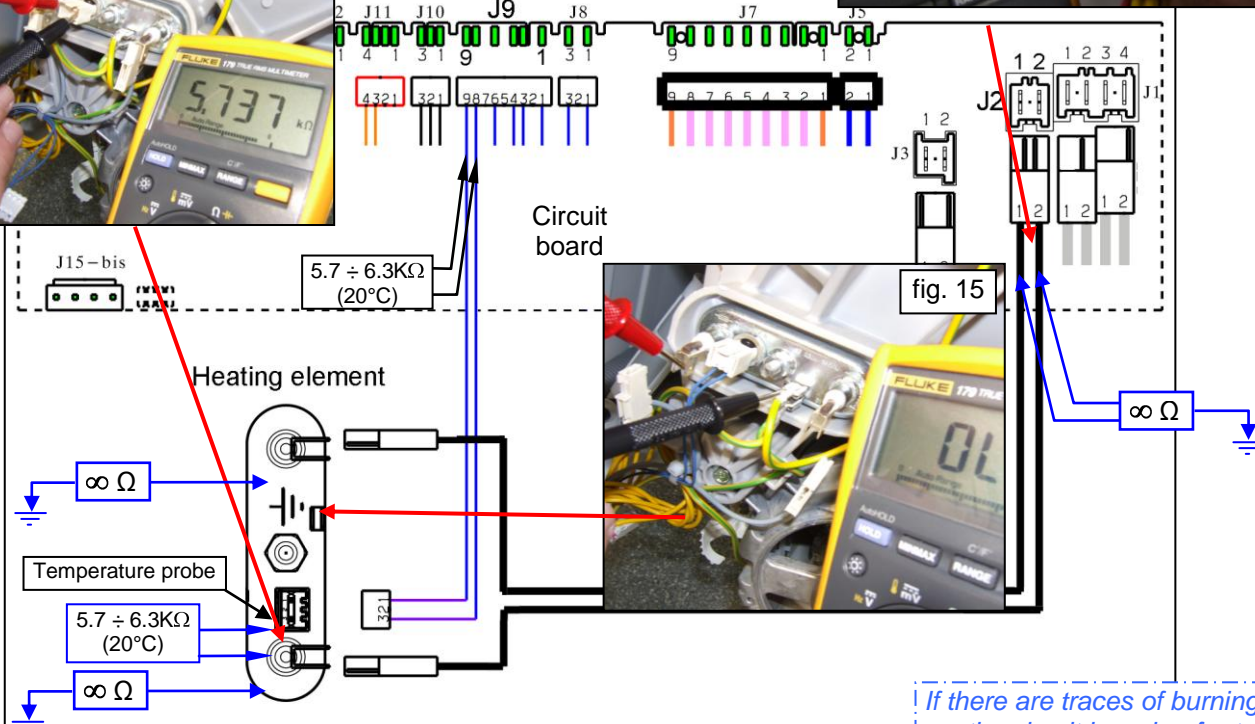
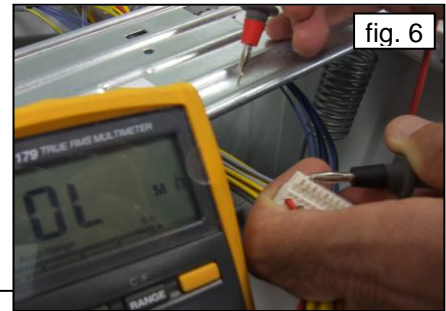
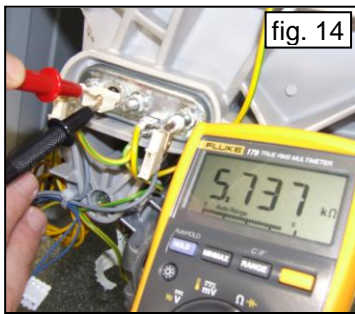
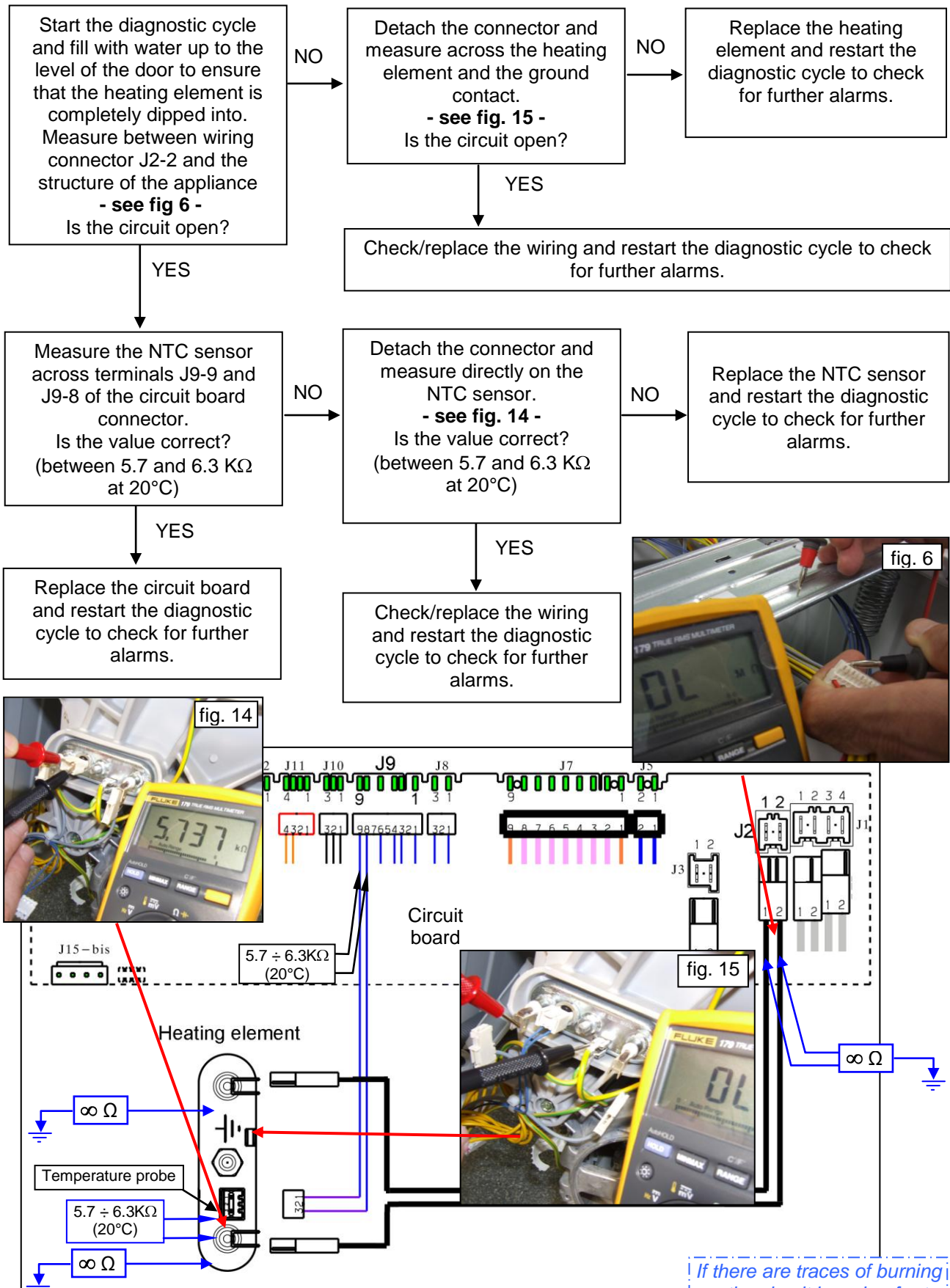

If there are traces of burning on the circuit board, refer to page 94

E62	E62: Overheating during washing (version WD)	E62
The temperature of the NTC sensor exceeds 88°C for more than 5 minutes.		

Checks to perform: Check that all the connectors are inserted correctly

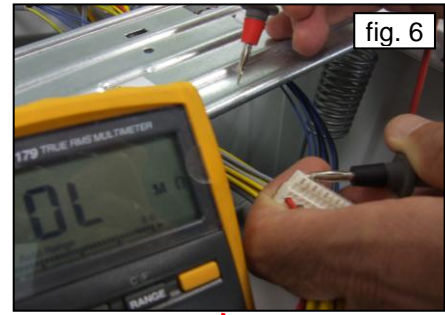
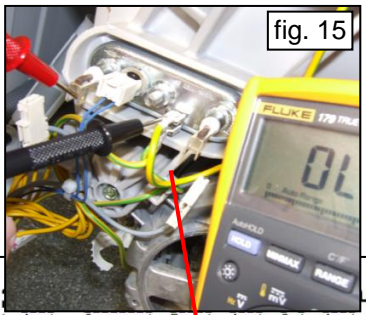
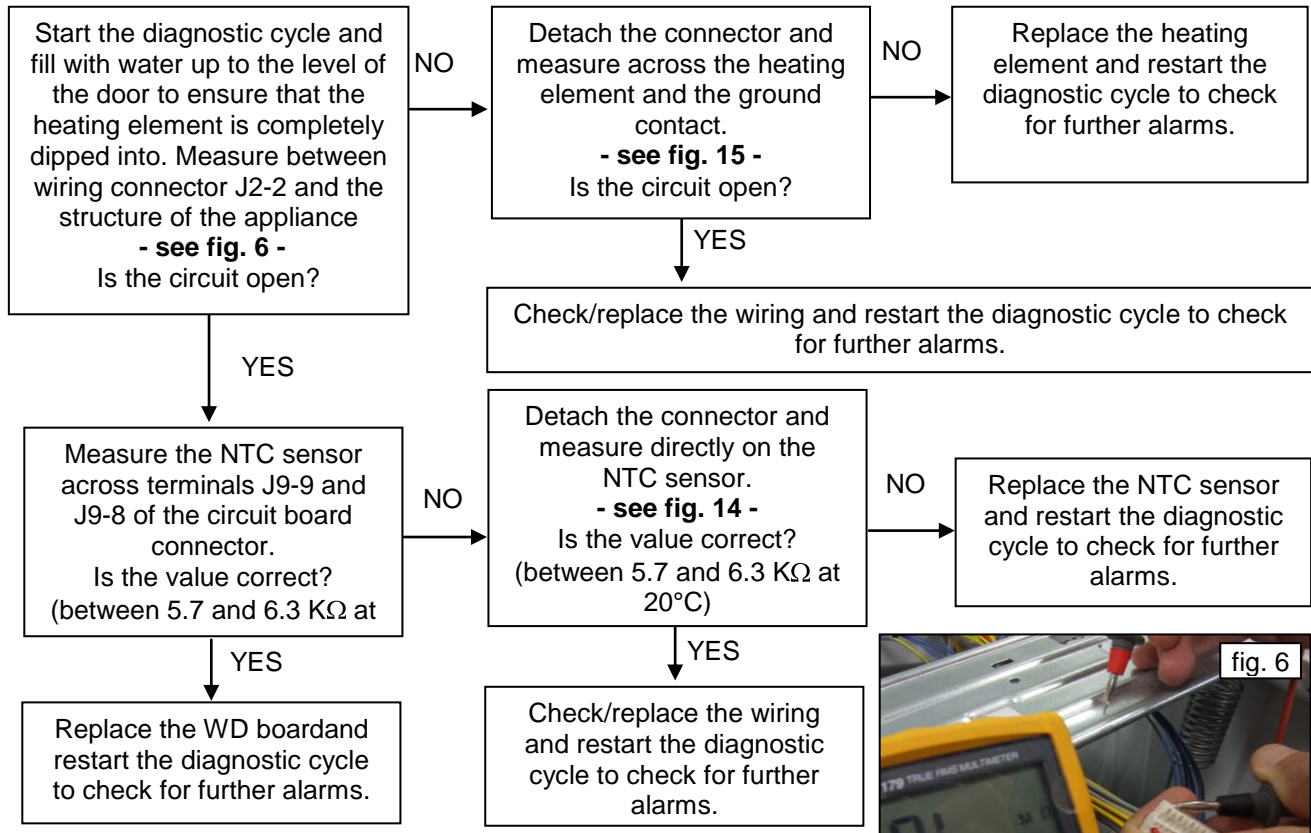

If there are traces of burning on the circuit board, refer to page 94

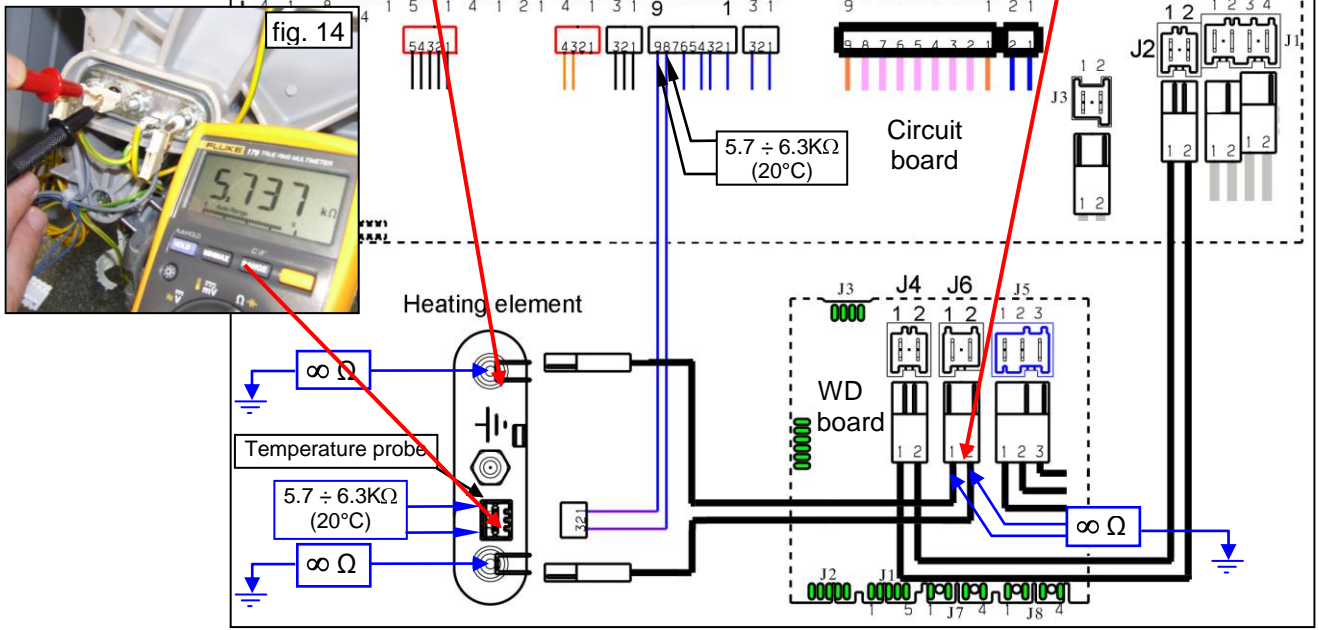

E66	E66: The contacts of the heating element power relay are always closed (version WM)	E66
------------	--	------------

Checks to perform: *Check that all the connectors are inserted correctly*

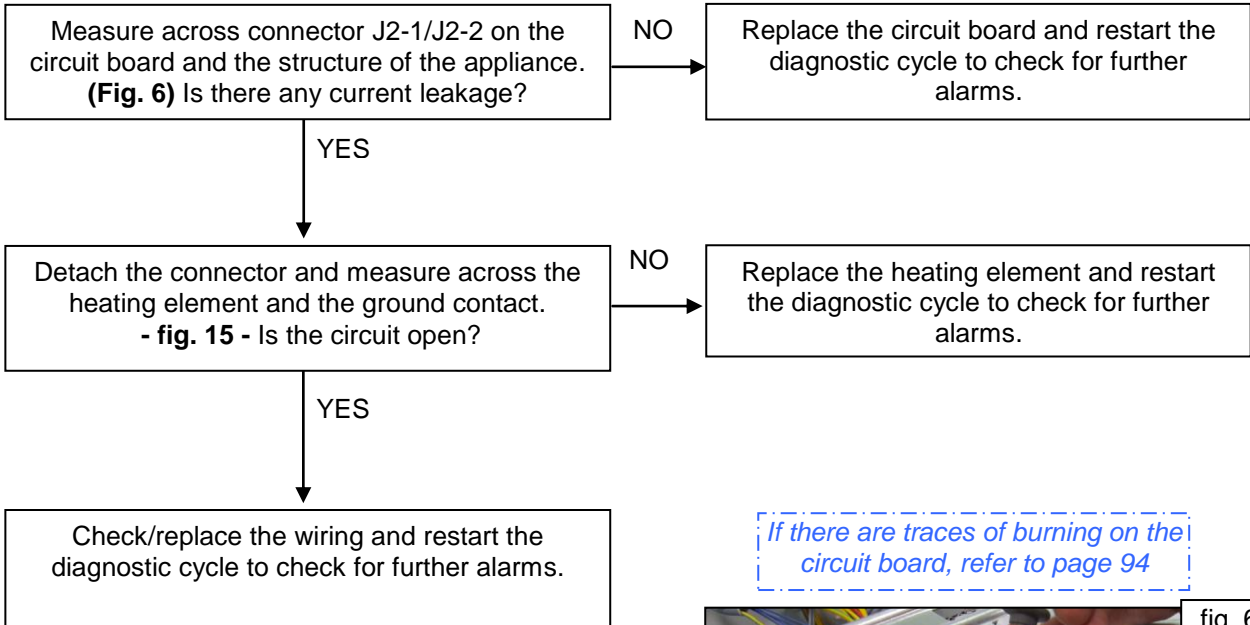

If there are traces of burning on the circuit board, refer to page 94

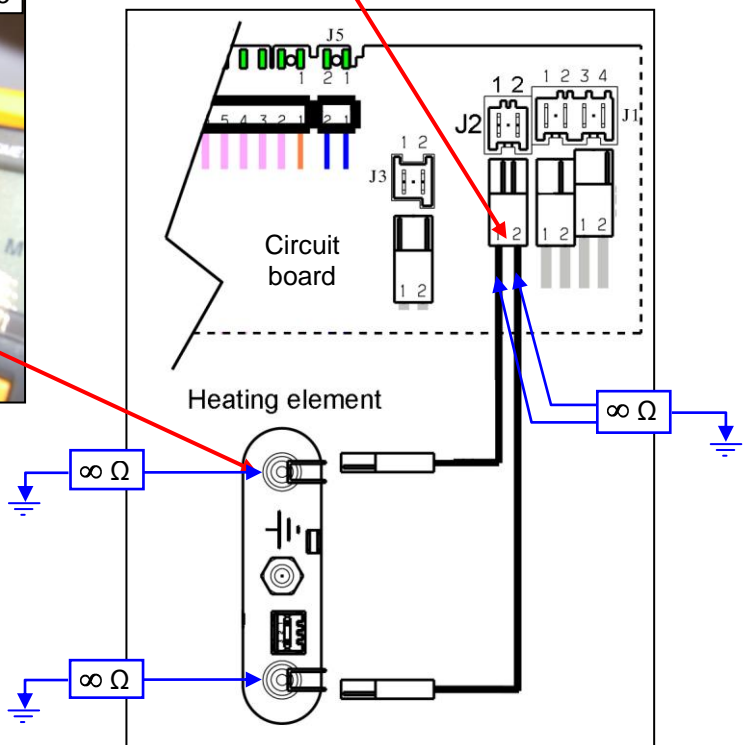
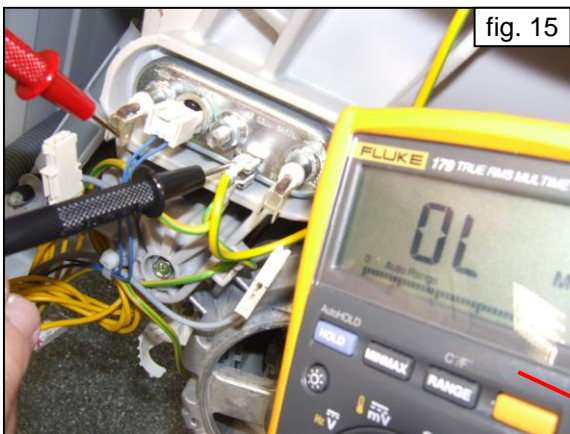
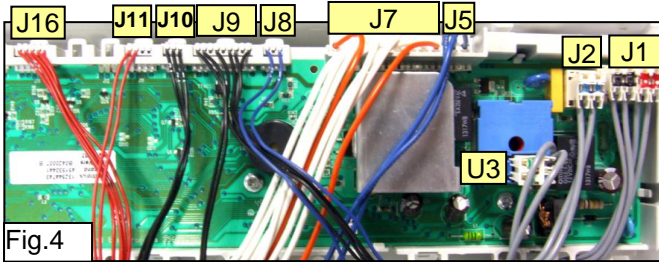

E66	E66: The contacts of the heating element power relay are always closed (version WD)	E66
------------	--	------------

Checks to perform: *Check that all the connectors are inserted correctly*

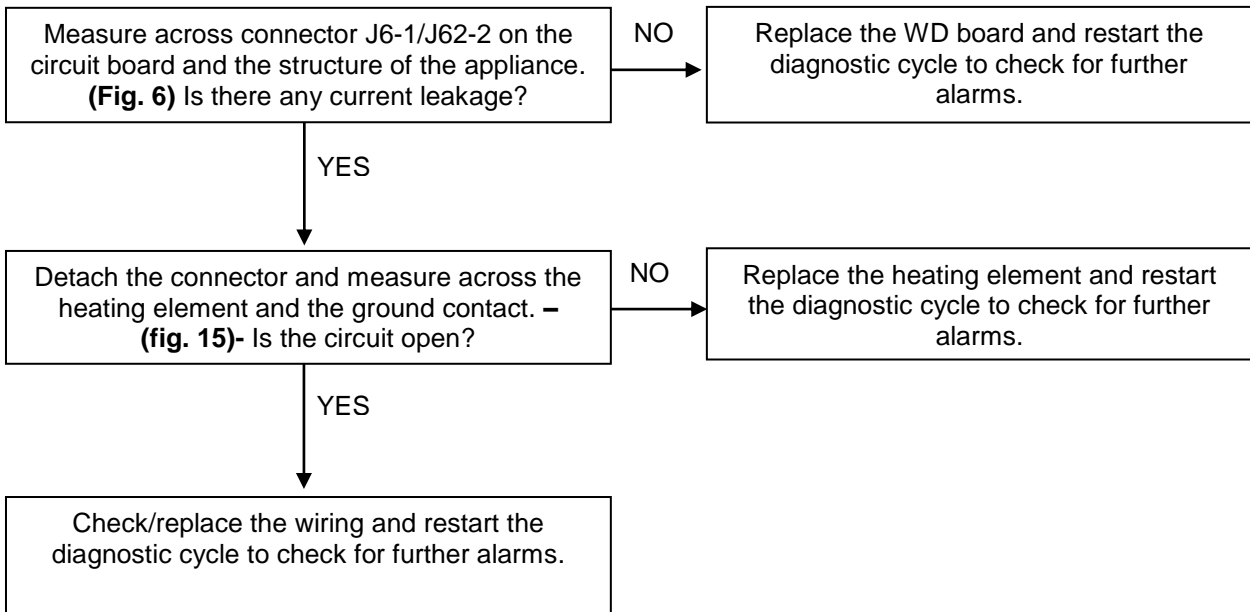

If there are traces of burning on the circuit board, refer to page 94

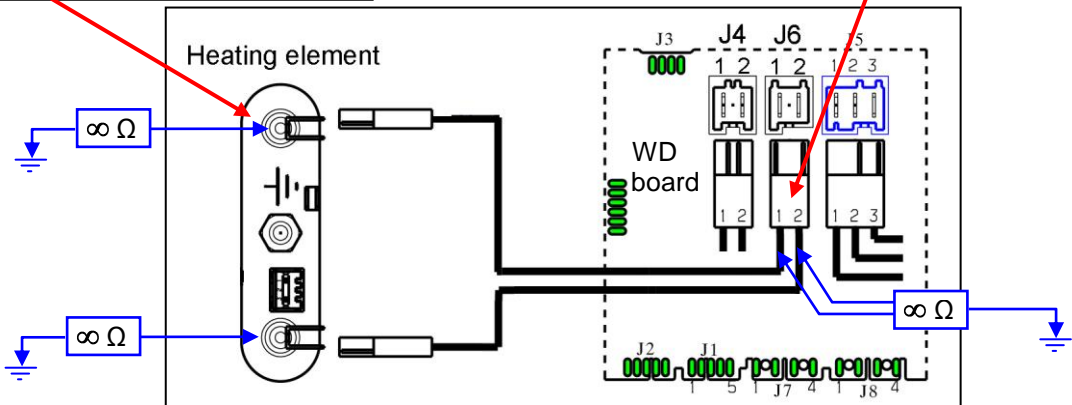
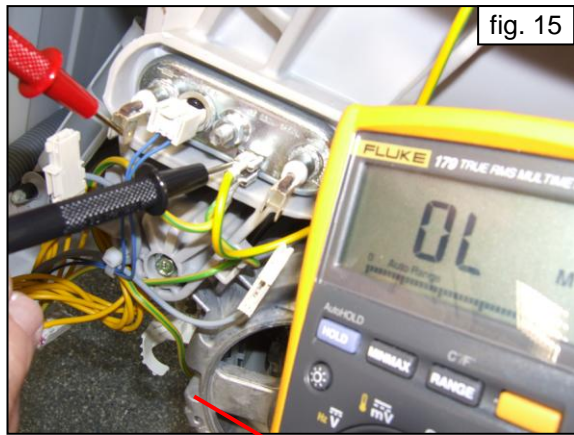
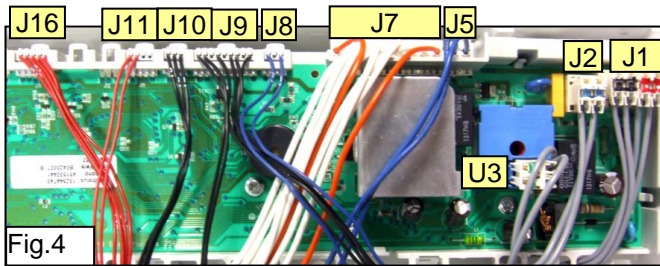

Checks to perform: Check that all the connectors are inserted correctly

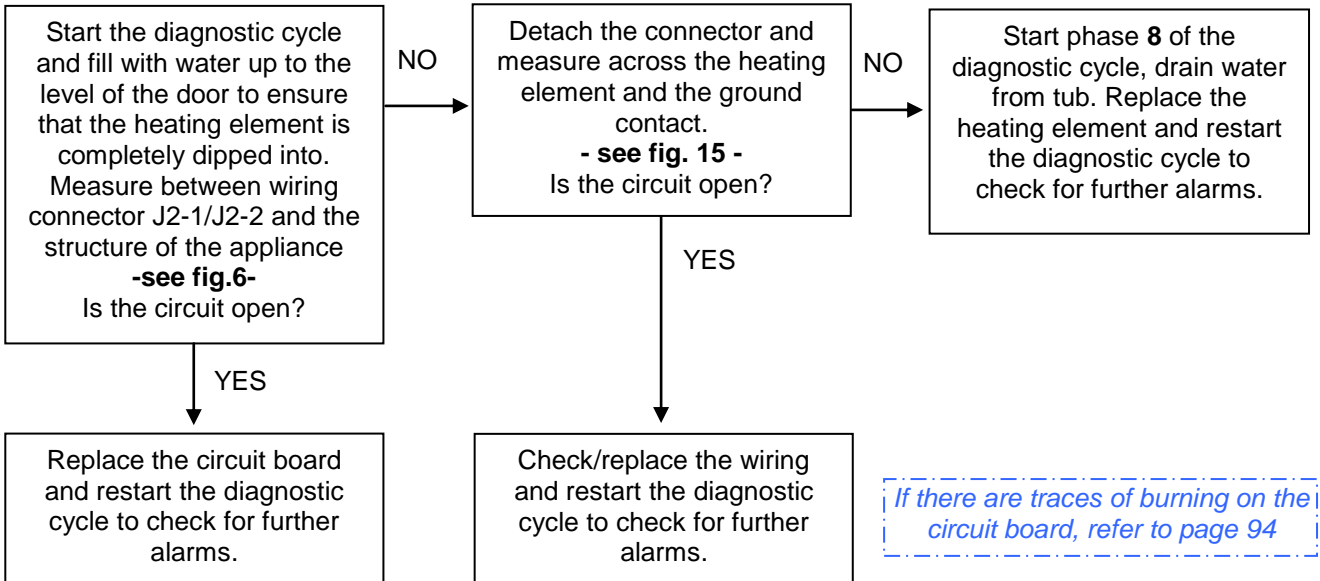

fig. 6

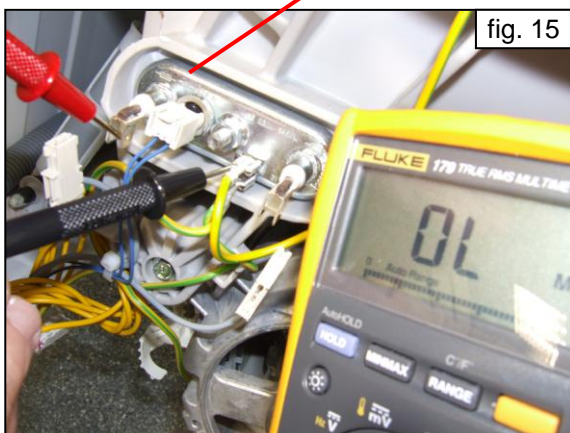
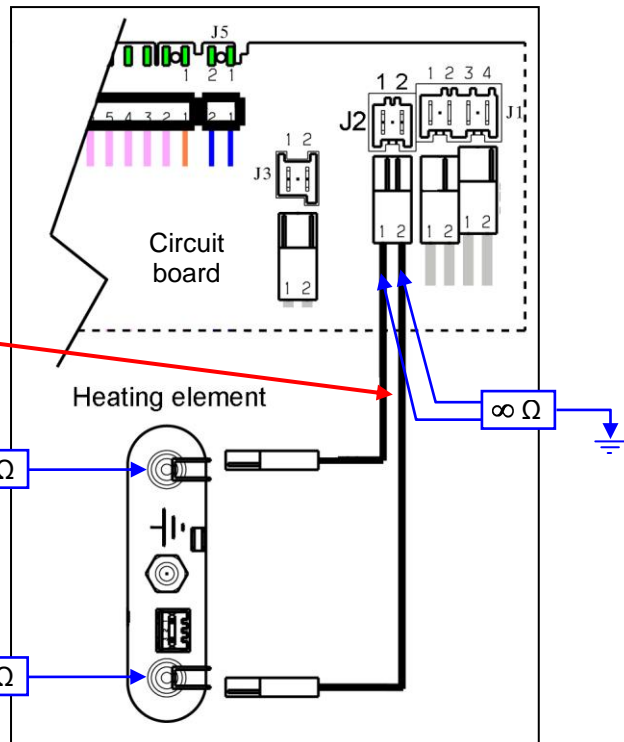

fig. 15

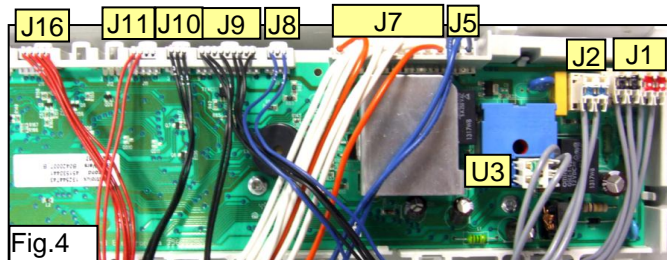
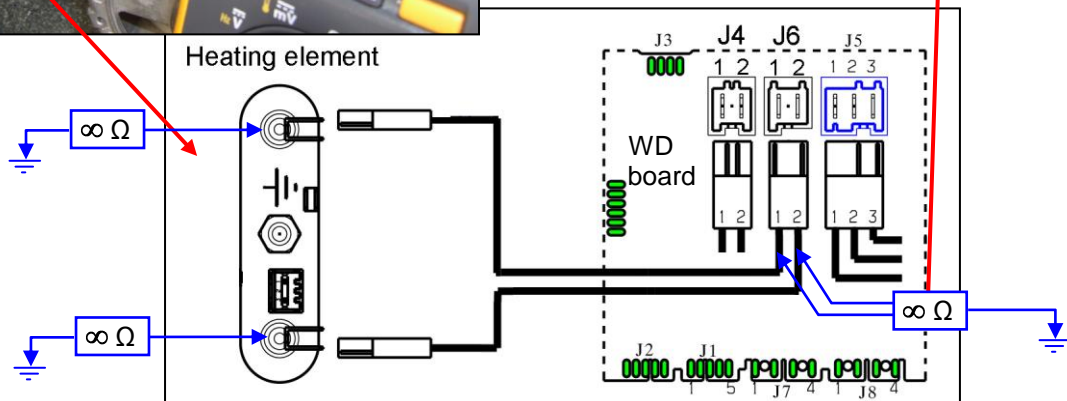
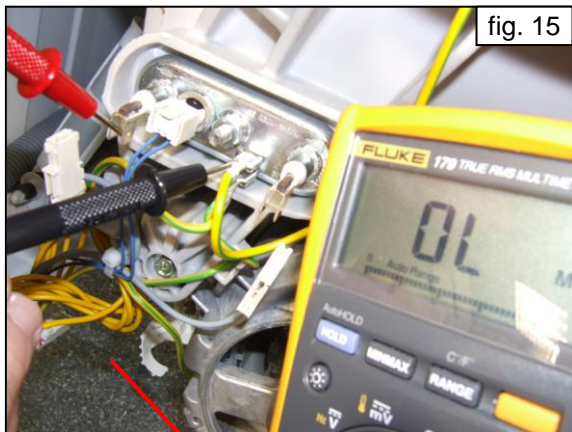
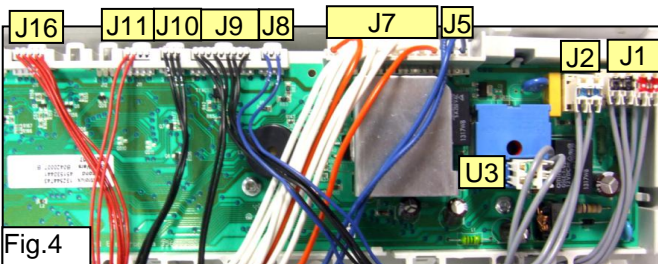
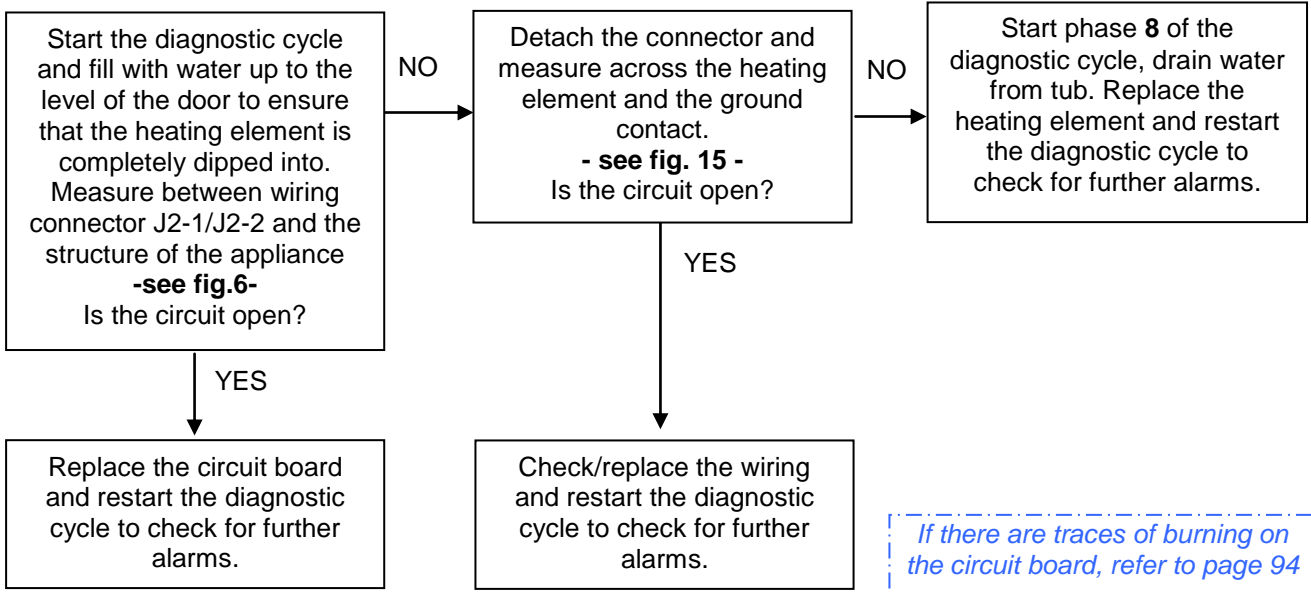

Fig.4

Checks to perform: Check that all the connectors are inserted correctly



Checks to perform: Check that all the connectors are inserted correctly

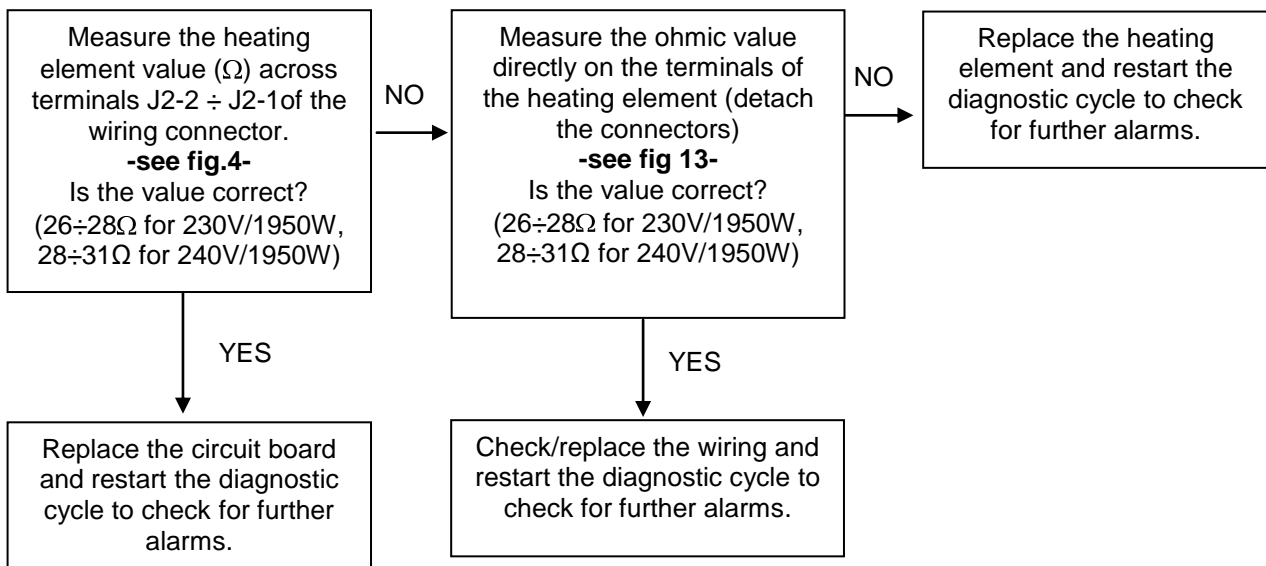

Fig.13

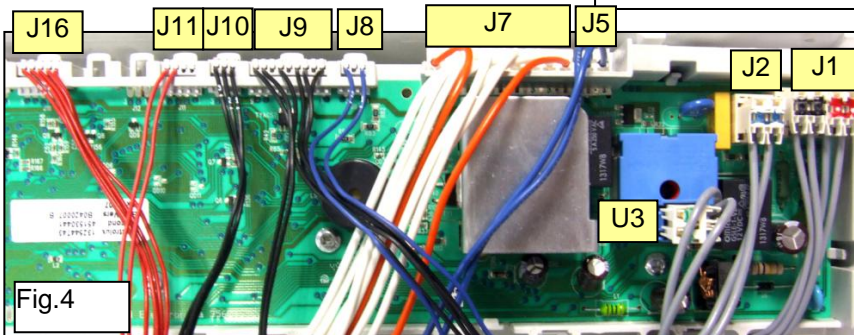
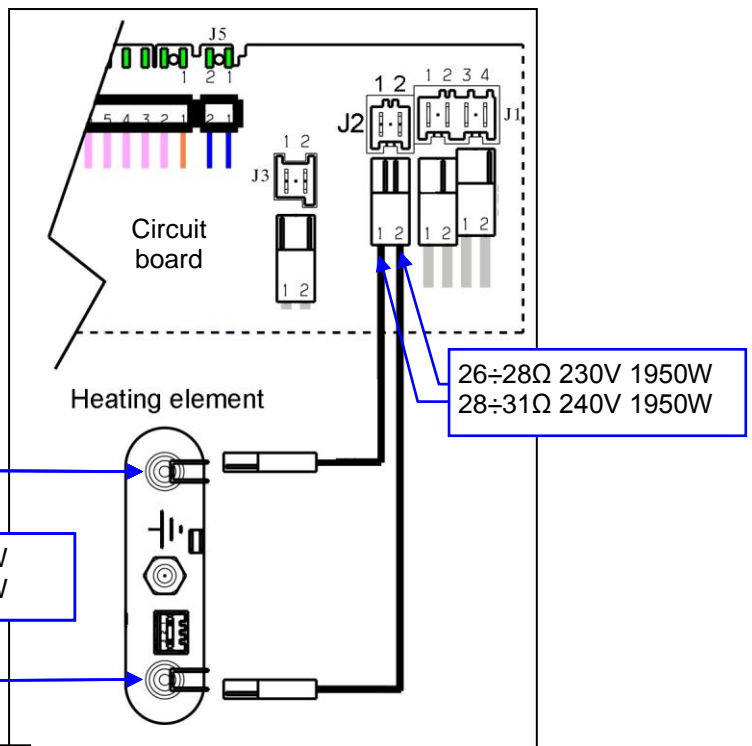

Fig.4

If there are traces of burning on the circuit board, refer to page 94

Checks to perform: Check that all the connectors are inserted correctly

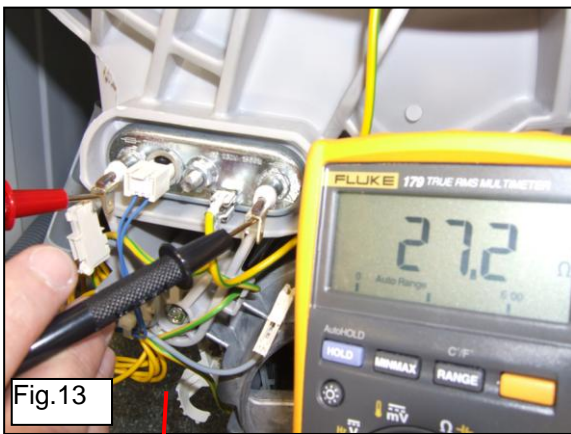
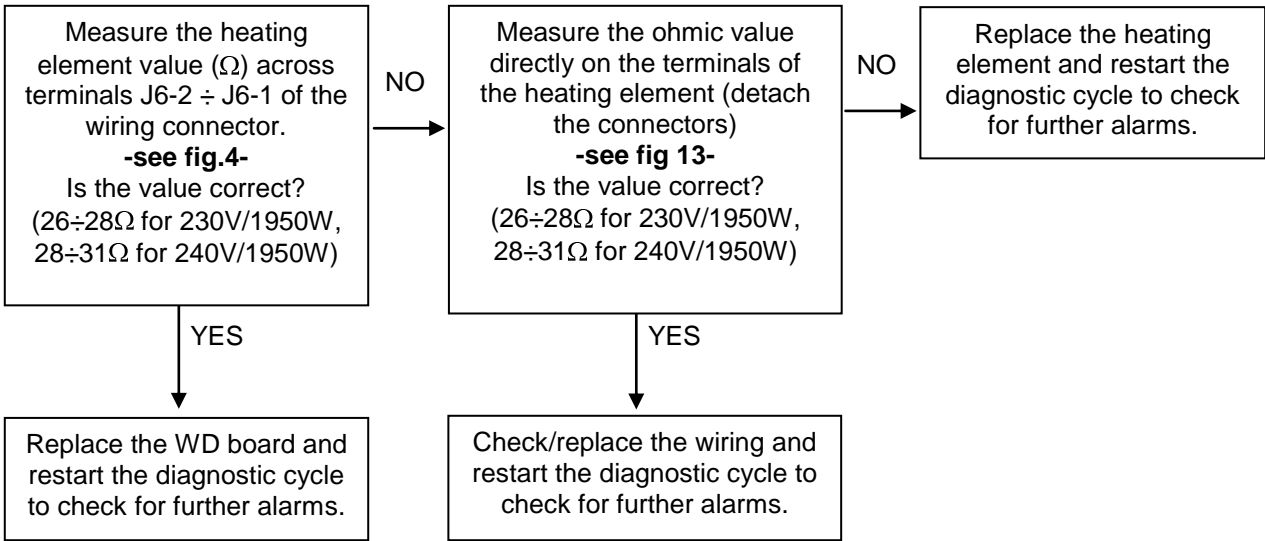

Fig.13

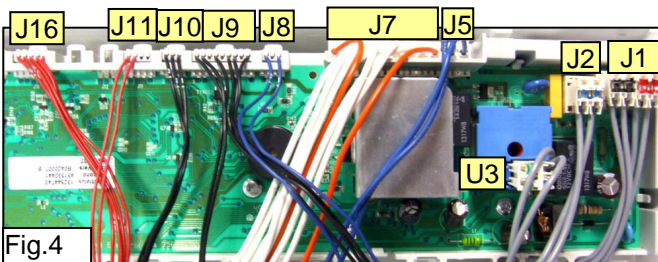
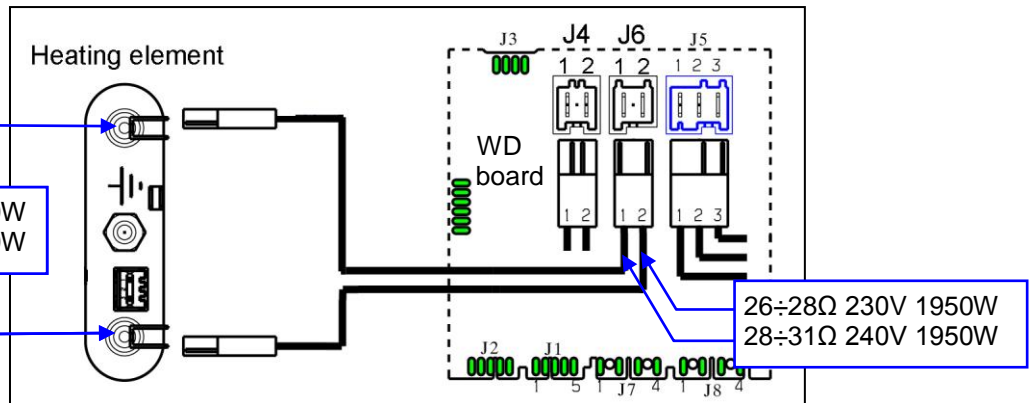
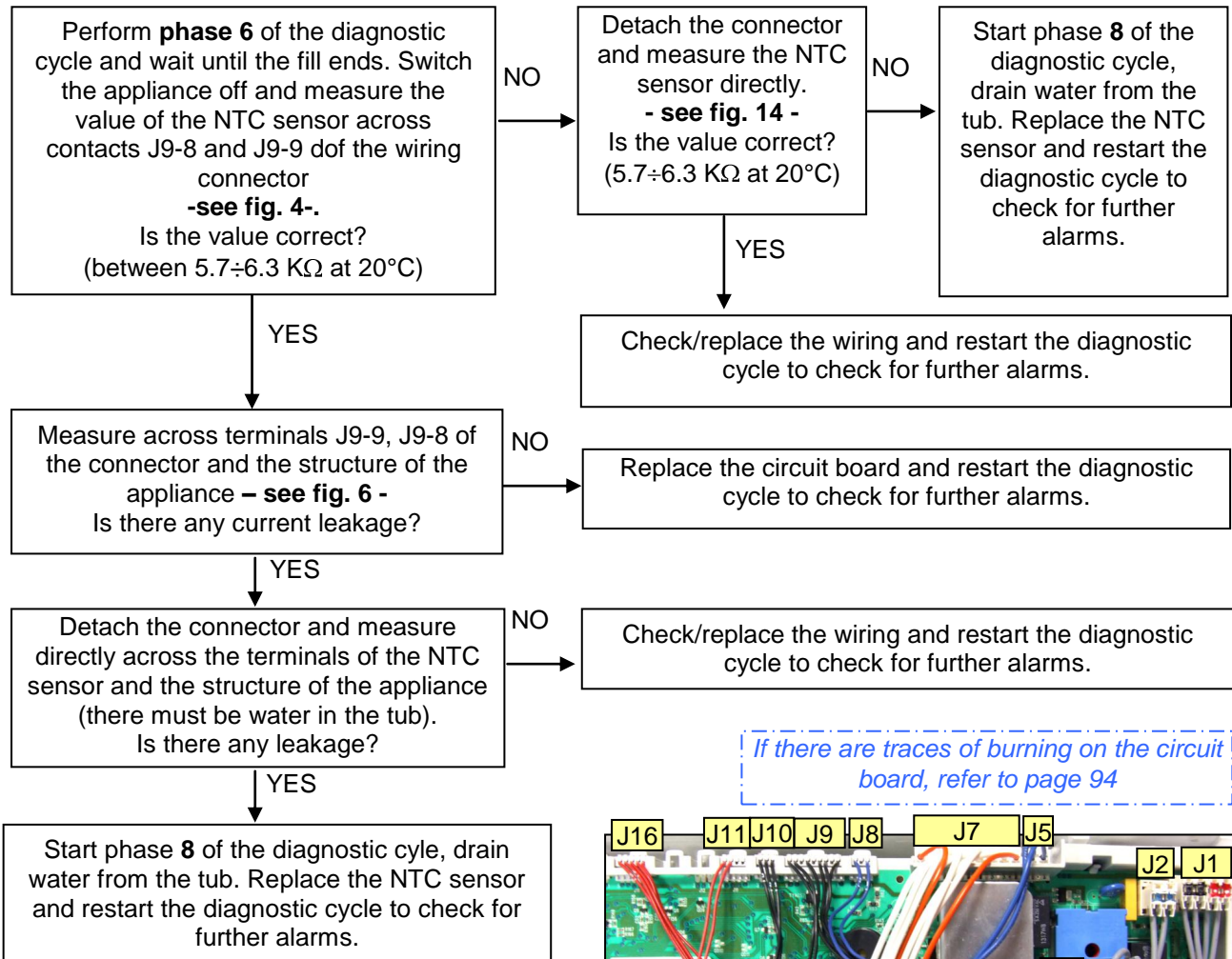

Fig.4

If there are traces of burning on the circuit board, refer to page 94

E71	E71: NTC washing sensor faulty	E71
Voltage not within limits (short-circuited or open)		

Checks to perform: *Check that all the connectors are inserted correctly*



If there are traces of burning on the circuit board, refer to page 94

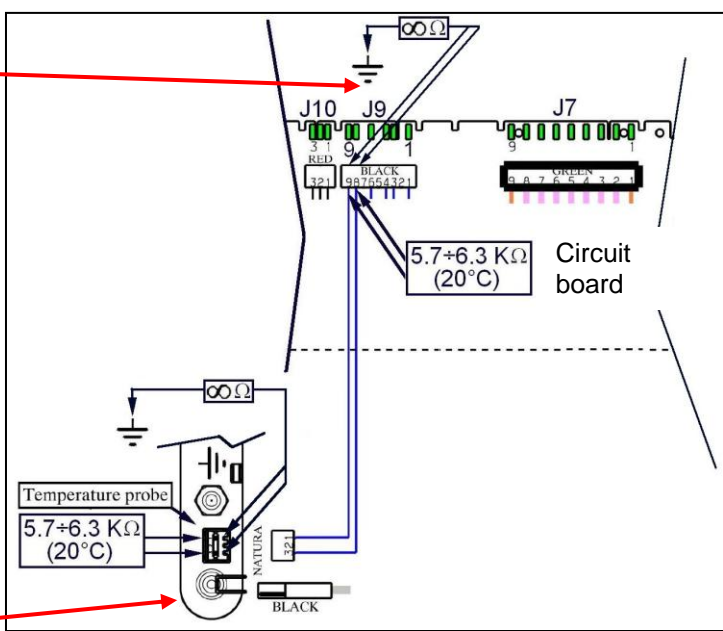
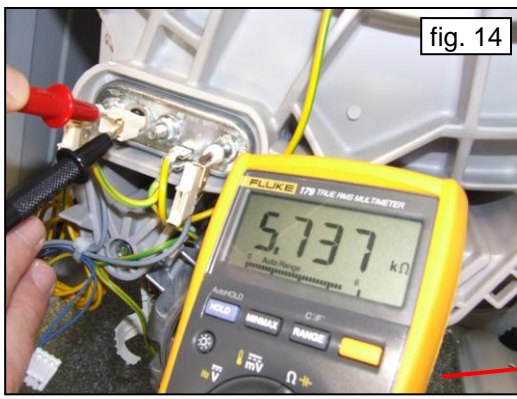
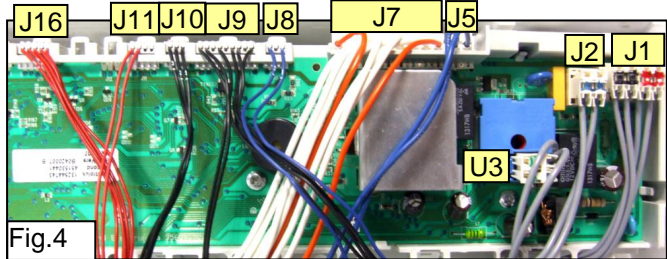

E72	E72: Drying NTC sensor on condenser faulty	E72
	Ohm value of the NTC out of limits	

Checks to perform: *Check that all the connectors are inserted correctly*

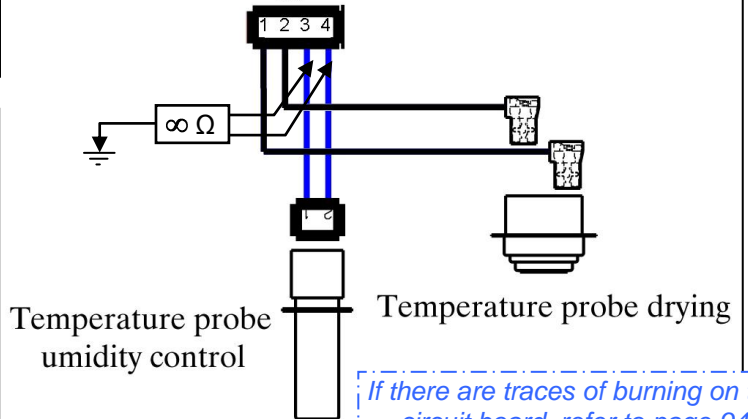
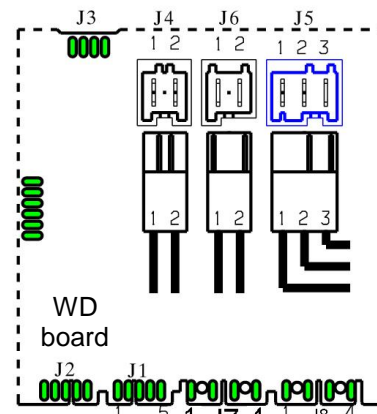
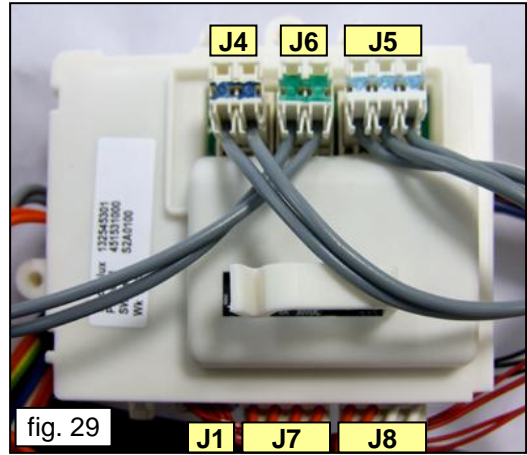
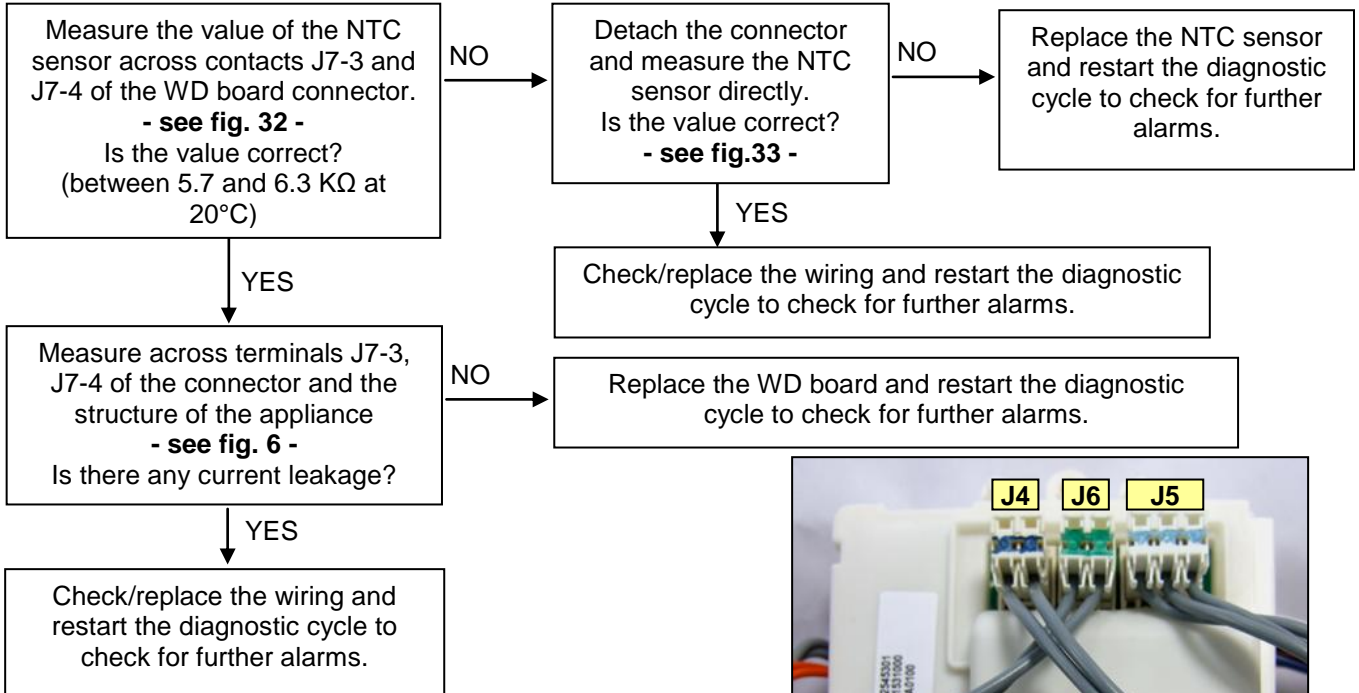

E73	E73: NTC sensor on drying duct faulty	E73
Ohm value of the NTC out of limits		

Checks to perform: *Check that all the connectors are inserted correctly*

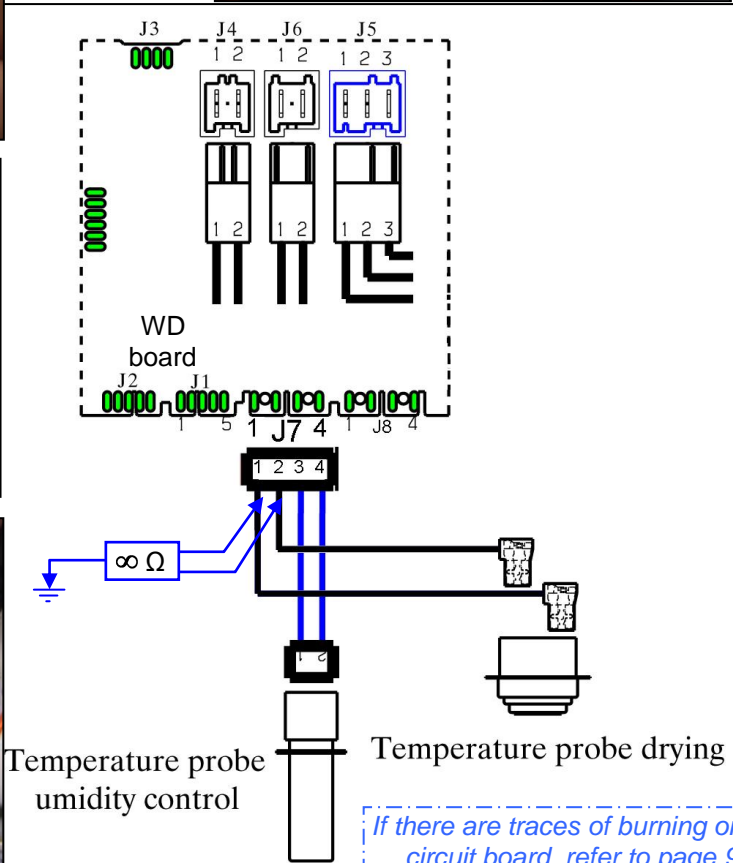
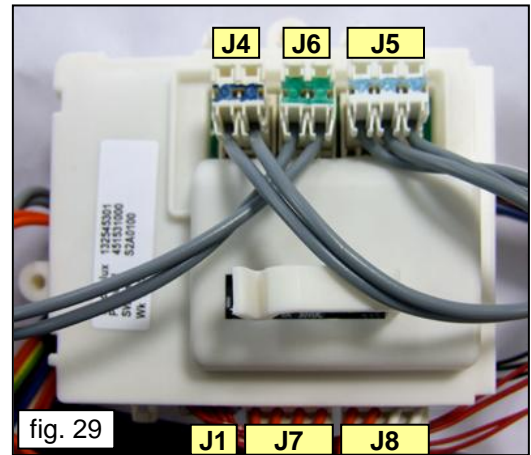
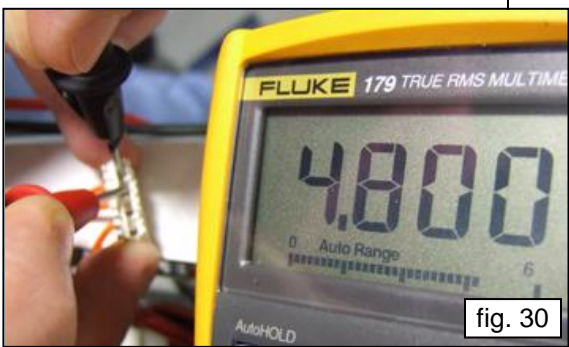
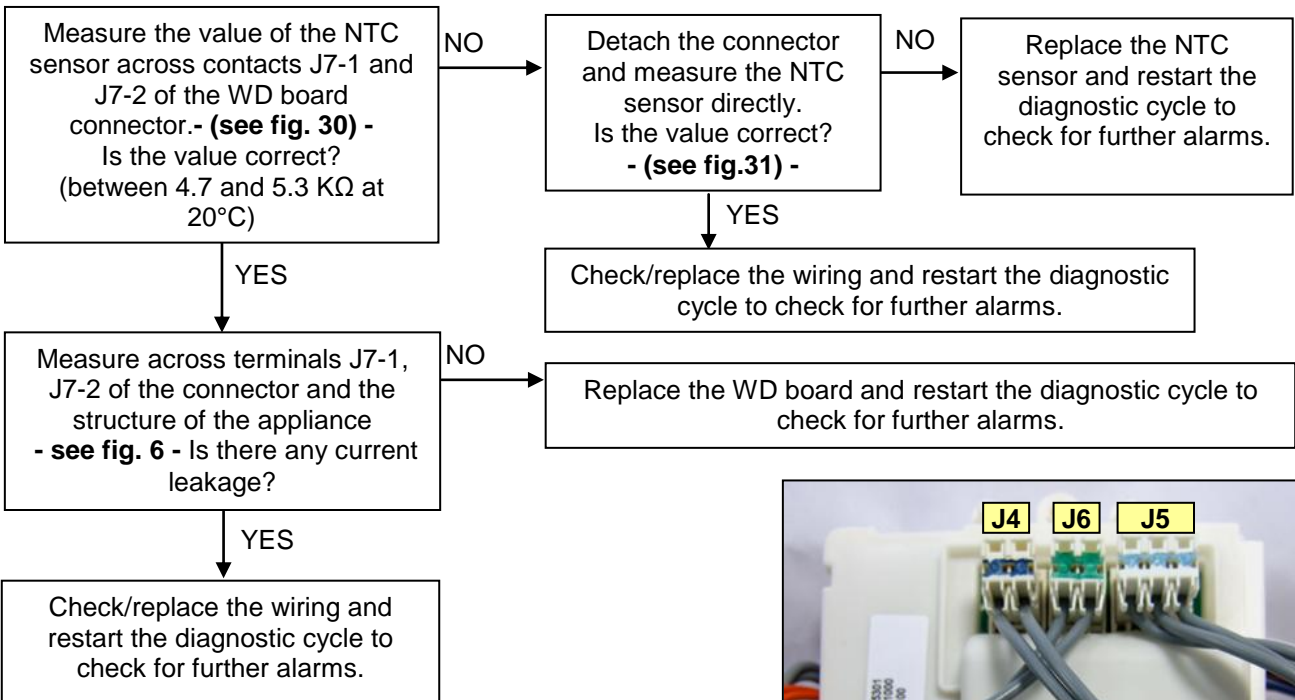

Checks to perform: Check that all the connectors are inserted correctly

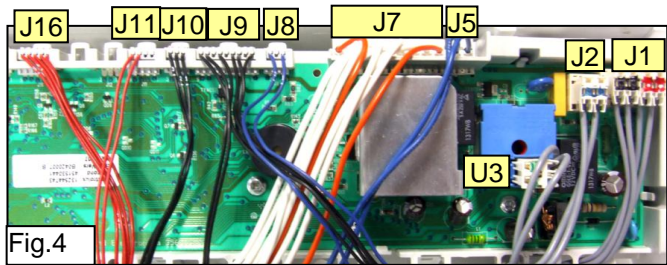
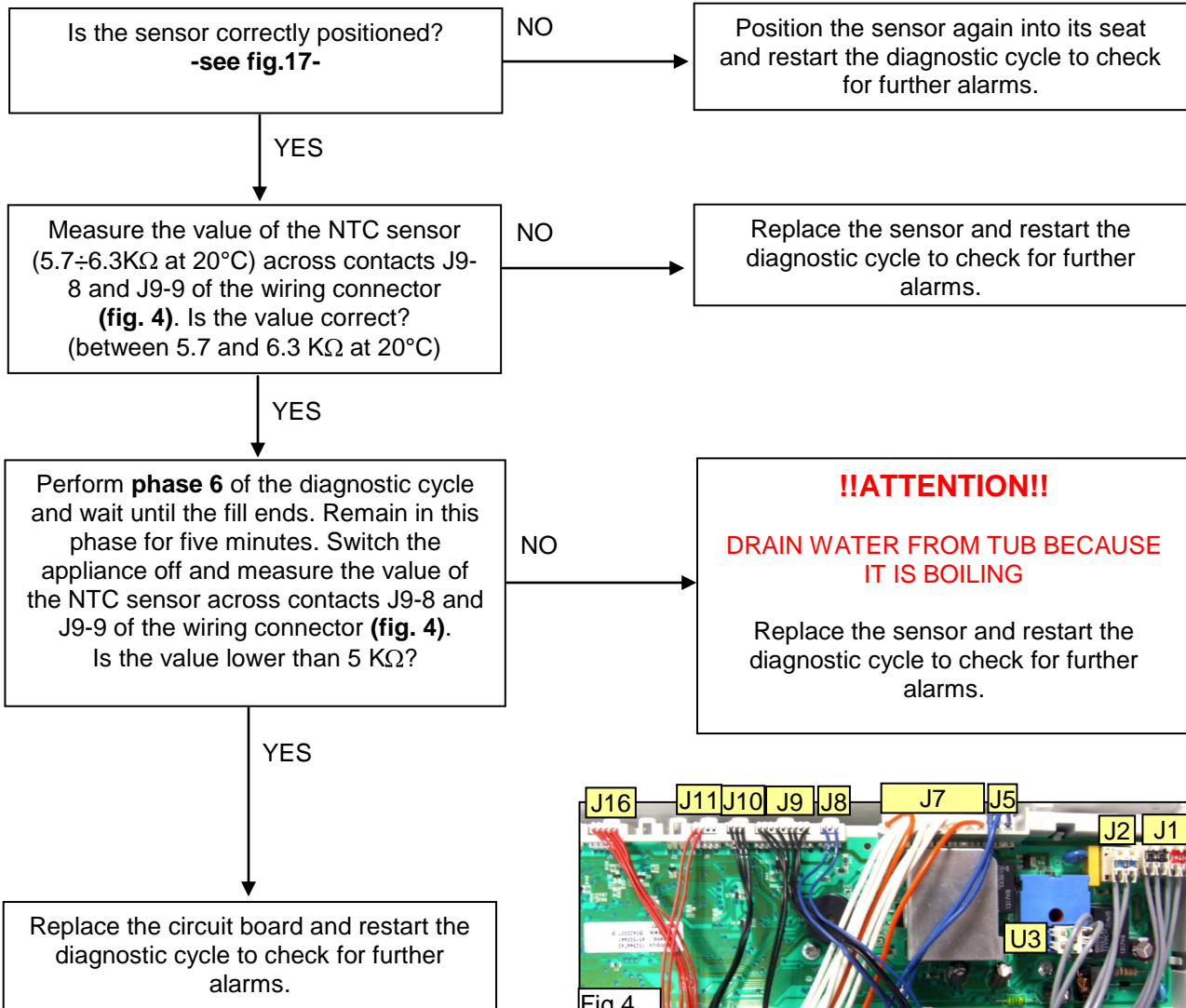
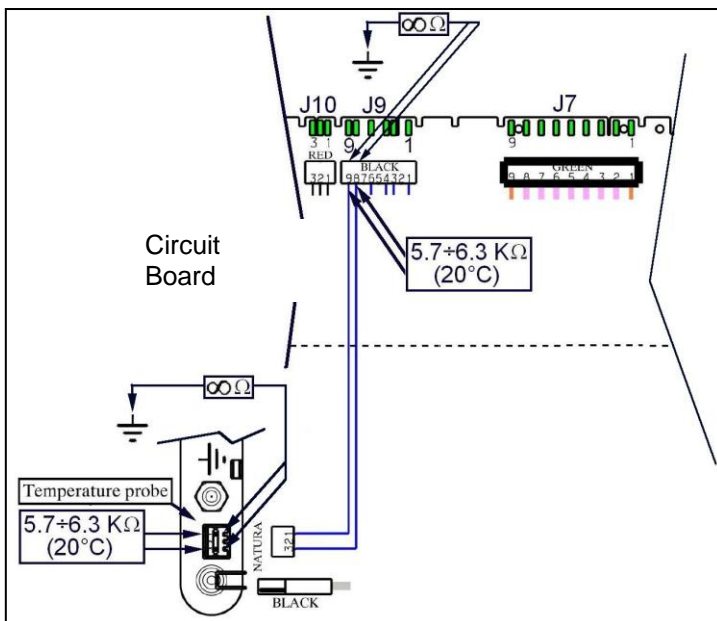

Fig.4



If there are traces of burning on the circuit board, refer to page 94

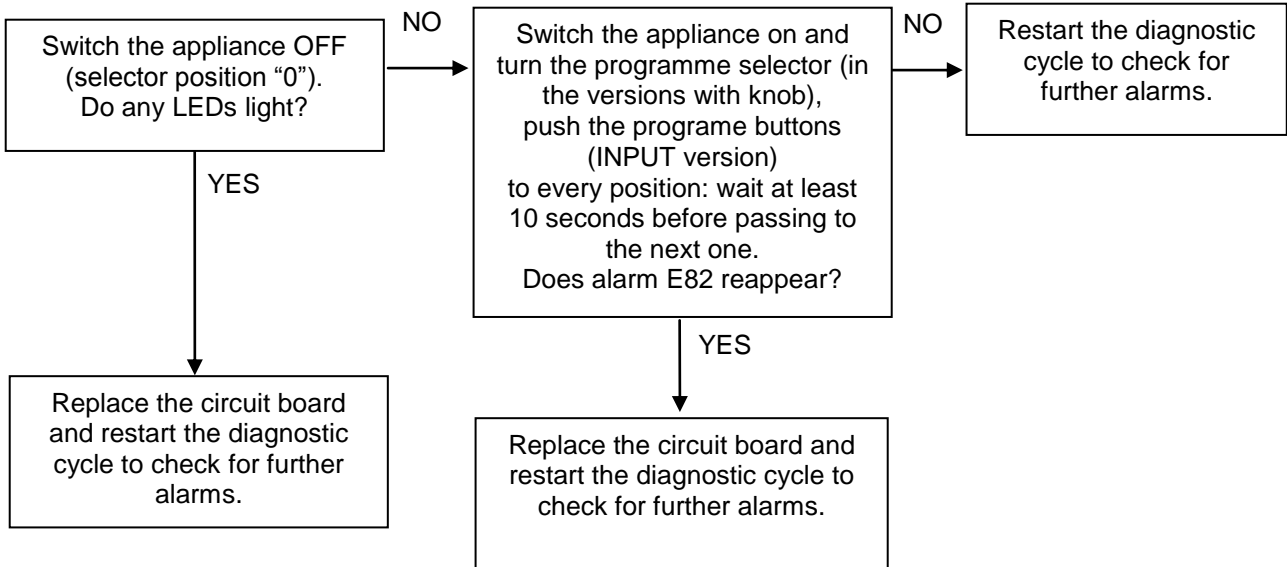

Fig.17

E82	E82: Error in reading the RESET/OFF position of the programme selector	E82
	Reading of position "0" of the selector when the appliance is switched on, or configuration error	

Checks to perform:

Check that all the connectors are inserted correctly



If there are traces of burning on the circuit board, refer to page 94

E83	E83: Error in reading the programme selector code	E83
	Code for the position of the selector not included in configuration data or configuration error	

Checks to perform: *Check that all the connectors are inserted correctly*

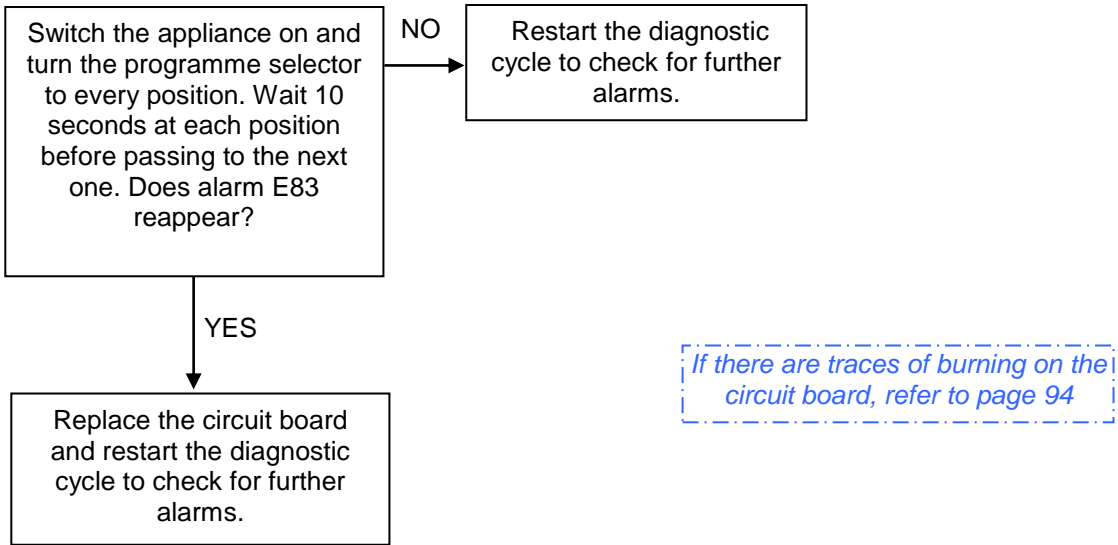

E91	E91: Communication error between user interface and main board	E91
	Incongruence of configuration values at the switching on of the appliance	

Checks to perform: *Check that all the connectors are inserted correctly*

Possible configuration error
Replace the circuit board and restart the diagnostic cycle to check for further alarms.

E92	E92: Protocol incongruence	E92
	Incongruence of configuration values at the switching on of the appliance	

Checks to perform: *Check that all the connectors are inserted correctly*

Possible configuration error
Replace the circuit board and restart the diagnostic cycle to check for further alarms.

E93	E93: Appliance configuration error	E93
	Incongruence of configuration values at the switching on of the appliance	

Checks to perform: *Check that all the connectors are inserted correctly*

Possible configuration error
Replace the circuit board and restart the diagnostic cycle to check for further alarms.

E94	E94: Washing cycle configuration error	E94
	Incongruence of configuration values at the switching on of the appliance	

Checks to perform: *Check that all the connectors are inserted correctly*

Possible configuration error
Replace the circuit board and restart the diagnostic cycle to check for further alarms.

E95	E95: Communication failed between EEprom and Microprocessor	E95
------------	--	------------

Checks to perform: *Check that all the connectors are inserted correctly*

Replace the circuit board and restart the diagnostic cycle to check for further alarms.

E97	E97: Incongruence between version of the control selector and configuration data	E97
	Incongruence between configuration data of the programmes and those of the selector	

Checks to perform: *Check that all the connectors are inserted correctly*

Possible configuration error
Replace the circuit board and restart the diagnostic cycle to check for further alarms.

EA1	EA1: Drum positioning system (DSP) faulty (top-loaders)	EA1
	No signal or discontinuous signal from the sensor for more than 10 seconds during actioning of the motor to position the drum	

Checks to perform: Check that all the connectors are inserted correctly

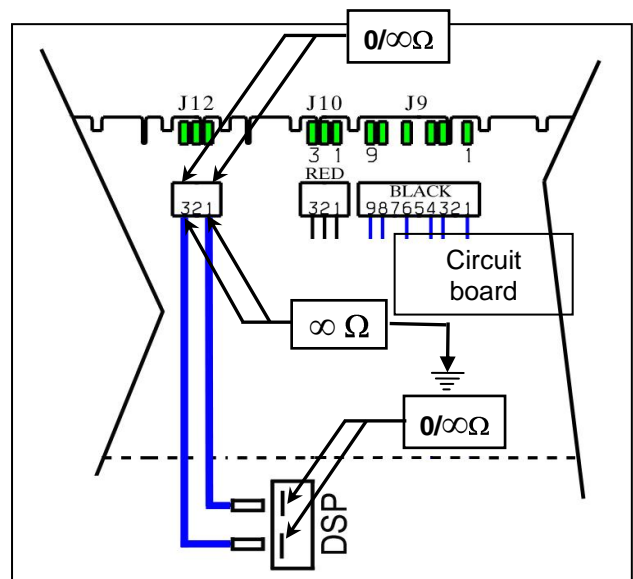
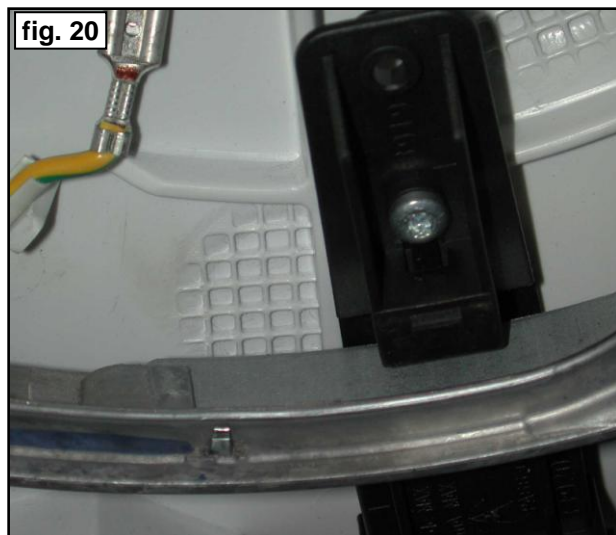
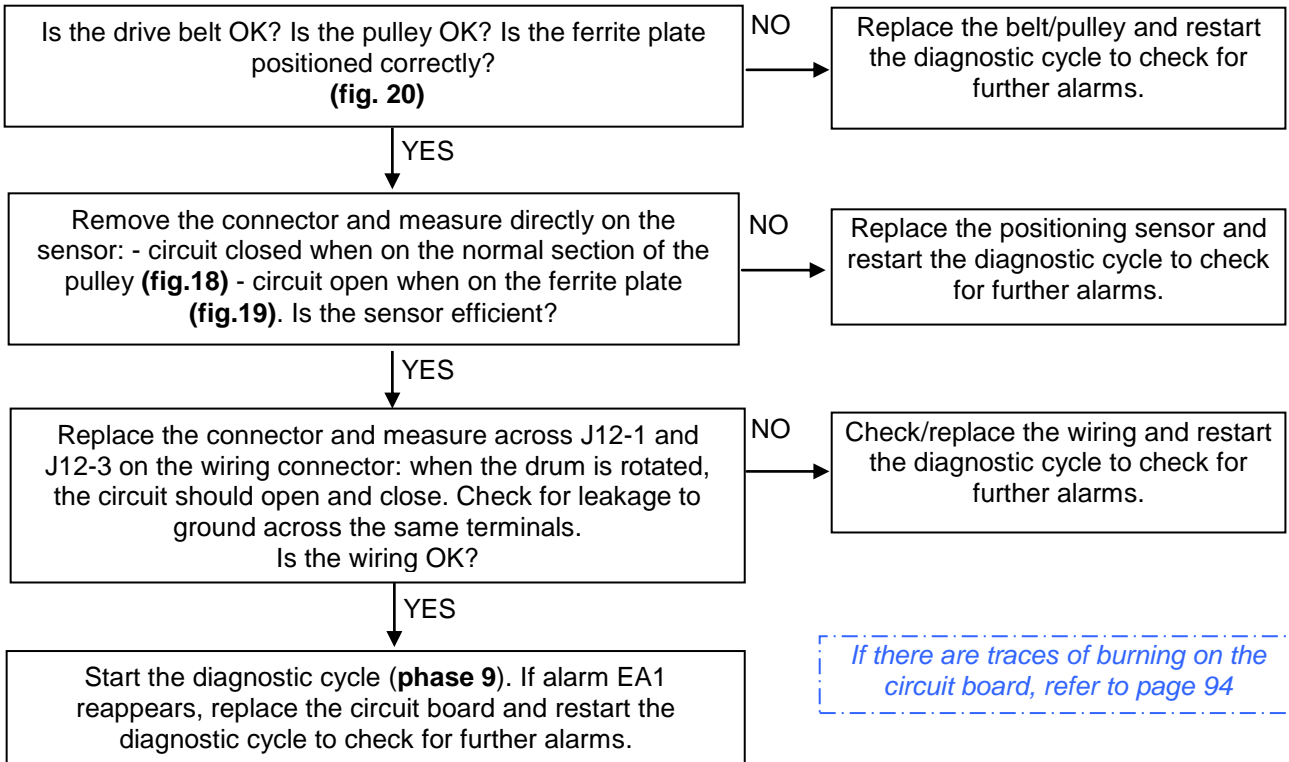

EA6	EA6: Drum flap faulty (top-loaders)	EA6
	Cycle immediately blocked if a not correct tachometric signal is identified for at least 3 seconds	

Checks to perform:

Check that all the connectors are inserted correctly

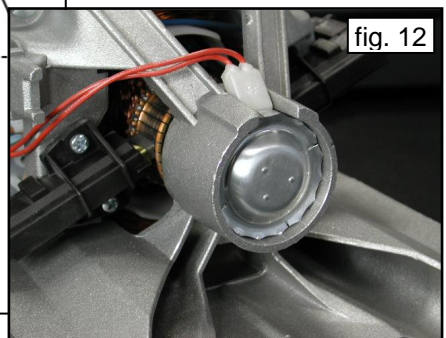
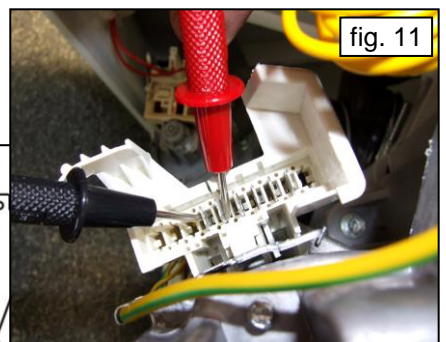
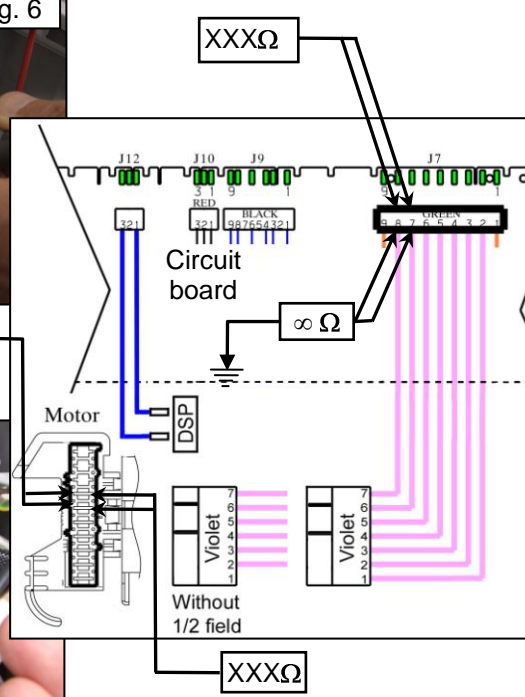
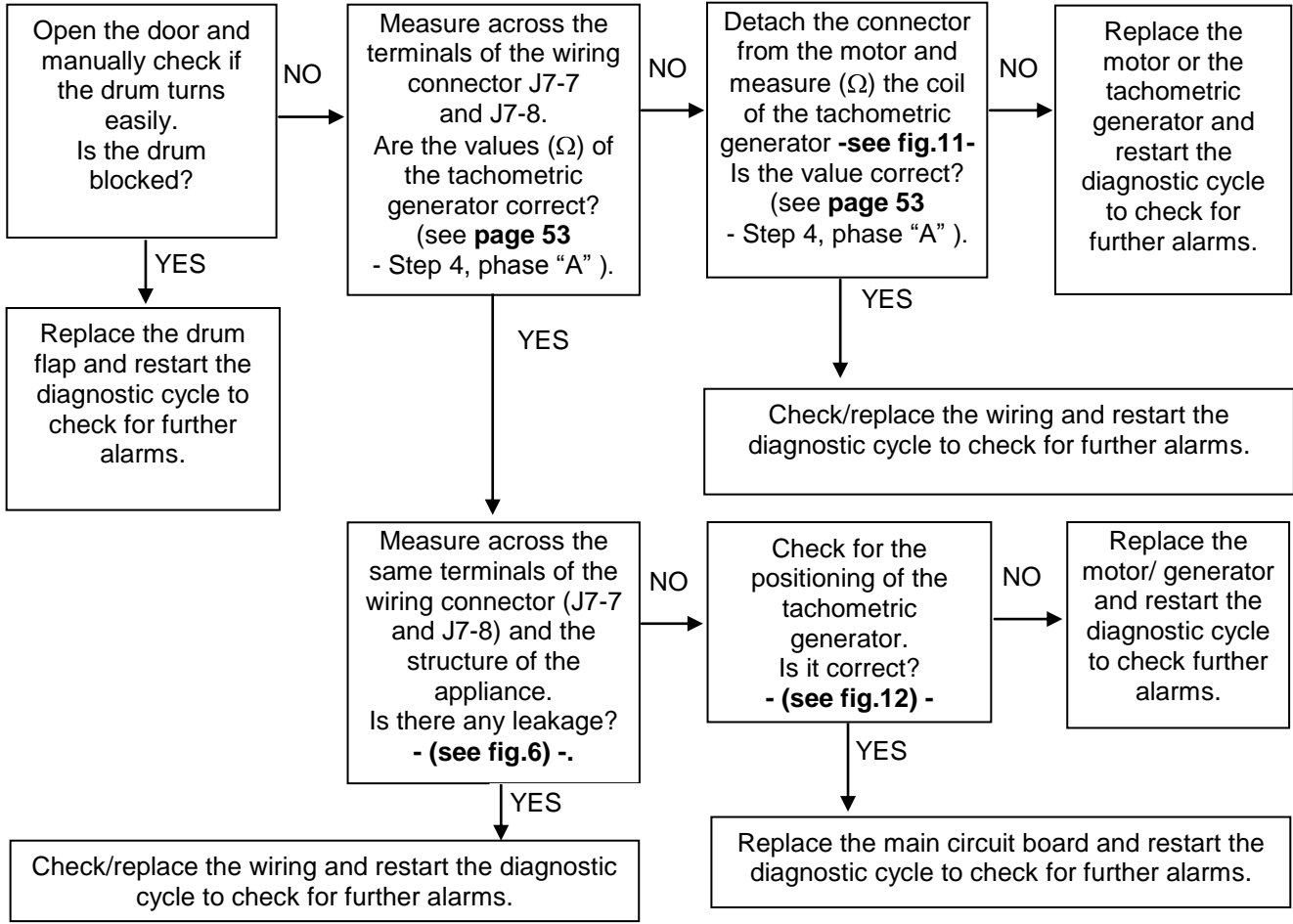

If there are traces of burning on the circuit board, refer to page 94

EH1	EH1: Incorrect mains frequency	EH1
	The power supply frequency is not within the configured limits	

Checks to perform: *Check that all the connectors are inserted correctly*

Important!

The appliance remains in alarm mode until the frequency returns to the correct value or the appliance is switched off (programme selector on "0"). Only the family of the alarm is displayed, and the diagnostic cycle cannot be started. The complete alarm can be read only when the alarm condition has ceased.

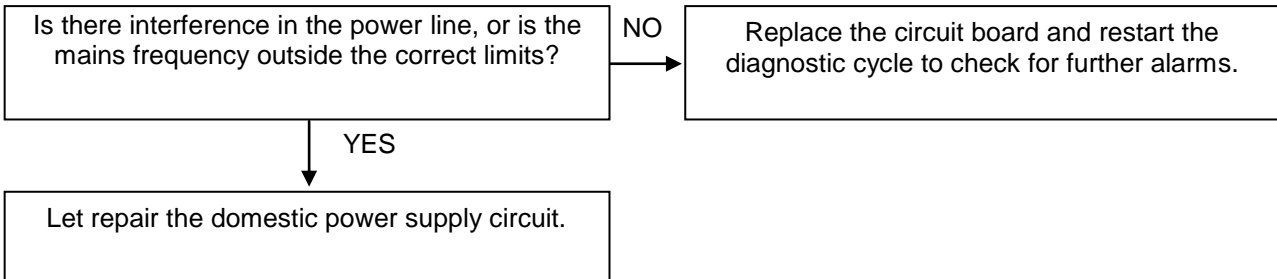

EH2	EH2: Mains voltage too high	EH2
	Mains voltage higher than configured voltage (for more than 10 seconds)	

Checks to perform: *Check that all the connectors are inserted correctly*

Important!

The appliance remains in alarm mode until the frequency returns to the correct value or the appliance is switched off (programme selector on "0"). Only the family of the alarm is displayed, and the diagnostic cycle cannot be started. The complete alarm can be read only when the alarm condition has ceased.

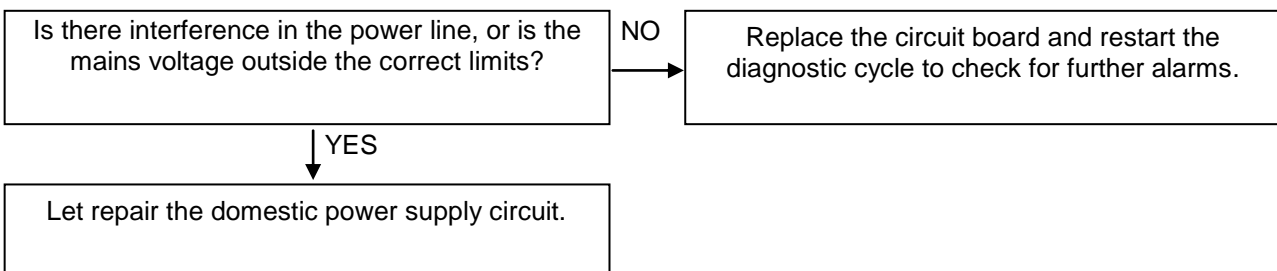

EH3	EH3: Mains voltage too low	EH3
	Mains voltage lower than configured voltage	

Checks to perform: *Check that all the connectors are inserted correctly*

Important!

The appliance remains in alarm mode until the frequency returns to the correct value or the appliance is switched off (programme selector on "0"). Only the family of the alarm is displayed, and the diagnostic cycle cannot be started. The complete alarm can be read only when the alarm condition has ceased.

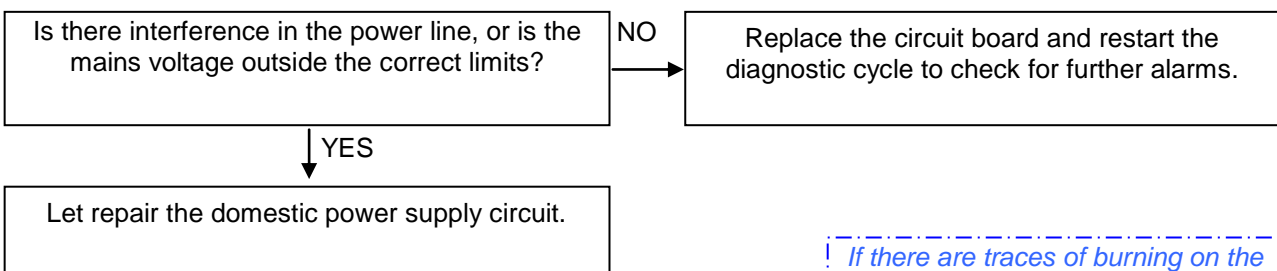

If there are traces of burning on the circuit board, refer to page 94

EF1	EF1: Drain hose blocked/throttled/too high; drain filter dirty/blocked	EF1
------------	---	------------

It is a warning that appears only at the end of the cycle. The machine has detected long draining phases during the cycle (Es. More than 20 seconds during draining after rinsing phase). Check/clean the drain filter.

EF2	EF2: Overdosing of detergent; drain hose blocked/throttled; drain filter dirty/blocked	EF2
------------	---	------------

Overdosing of detergent. The system has detected an over foaming during draining phases. Advice Customer to use the right quantity of detergent and verify that drain filter and drain system are clean.

EF3	EF3: Intervention of Aqua Control device	EF3
------------	---	------------

It warns about the presence of water at the bottom of the appliance. Check for any possible water leaks and the correct positioning of the float of the Aqua Control device.
And if the intervention is caused by overheating of the water drain pump: check for any objects that might be blocking the normal functioning of the pump rotor.

EF4	EF4: Low water fill pressure and solenoid open	EF4
------------	---	------------

Flowmeter faulty – Wiring faulty

EF5	EF5: Load too unbalanced, skipping of spin phases	EF5
------------	--	------------

It is a warning of load too unbalanced. During the spin phases the load is excessively unbalanced. Tell the user to load more clothes in the drum and not single clothes.

EF6	EF6: Appliance reset	EF6
------------	-----------------------------	------------

No action to be carried out, if it does not disappear, replace the circuit board.

EC1	EC1: Water fill solenoids blocked	EC1
	The flowmeter detects water filling even if the solenoid is not controlled	

Checks to perform: *Check that all the connectors are inserted correctly*

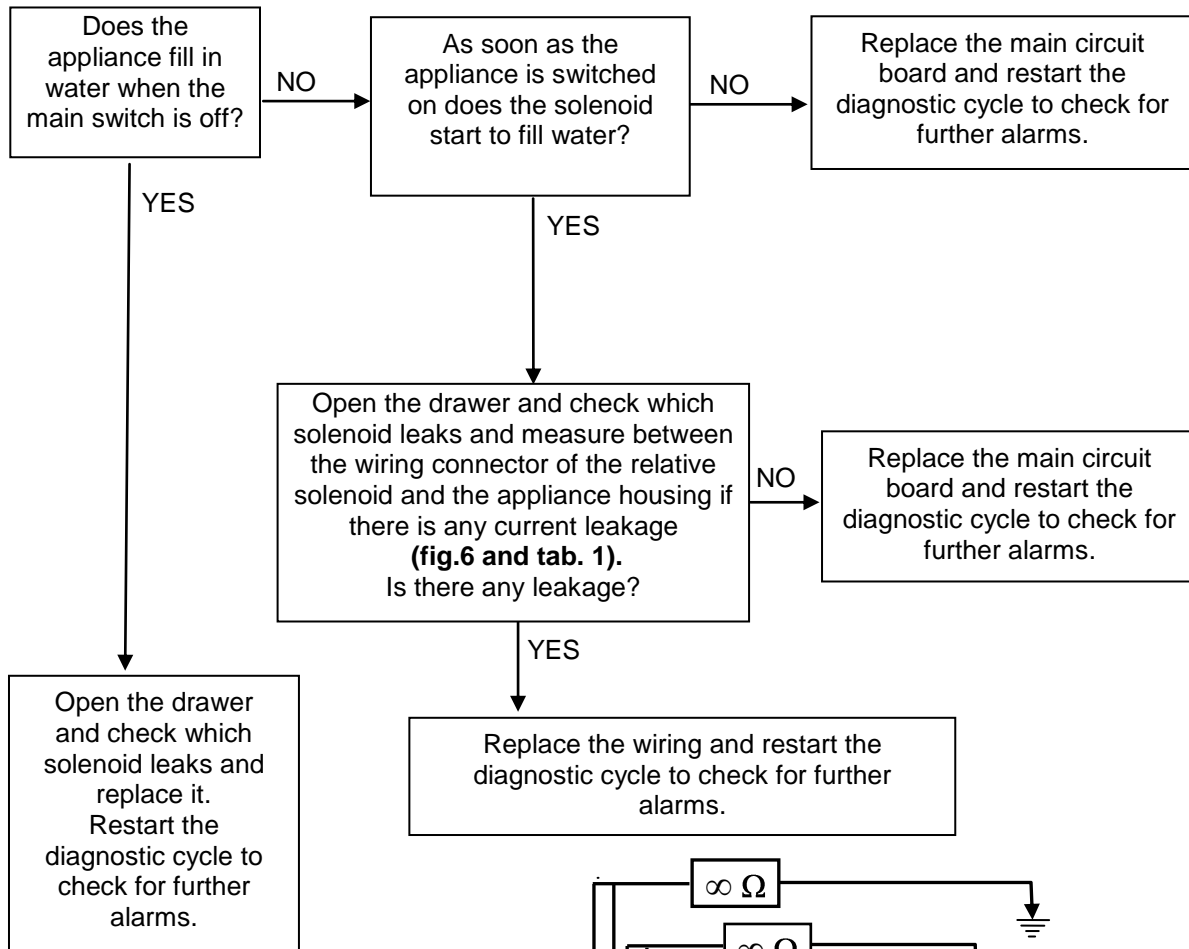
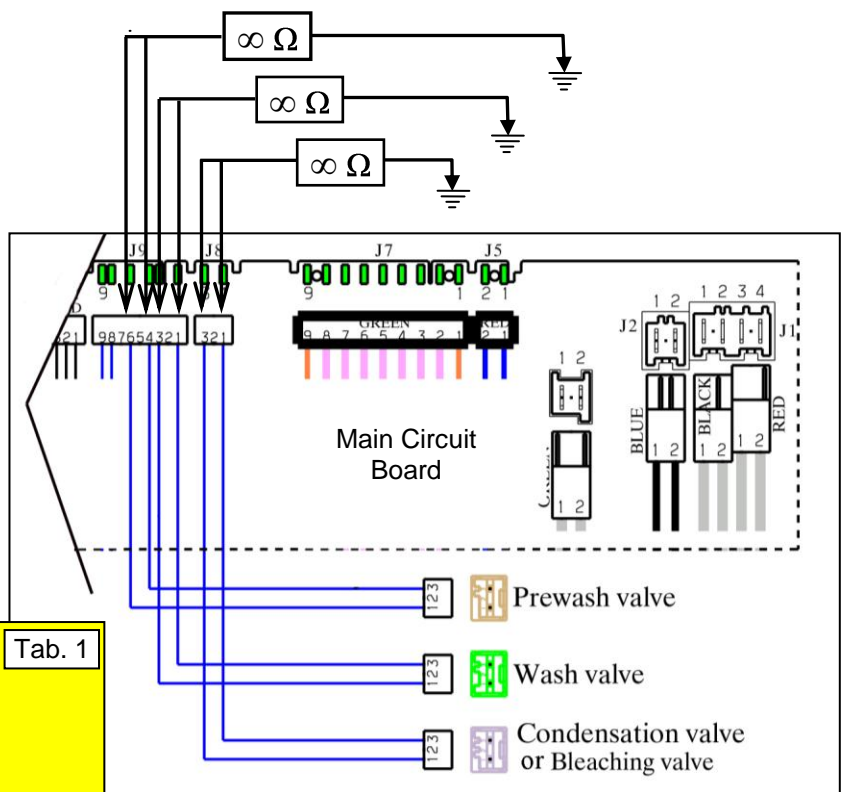

fig. 6



Tab. 1

Version WM
 Across J8-1 and J8-3 bleach solenoid
 Across J9-1 and J9-3 wash solenoid
 Across J9-4 and J9-6 prewash solenoid

Version WD
 Across J8-1 and J8-3 condensation solenoid
 Across J9-1 and J9-3 wash solenoid
 Across J9-4 and J9-6 prewash solenoid

If there are traces of burning on the circuit board, refer to page 94

ED1	ED1: Communication problems between main circuit board and WD board	ED1
------------	--	------------

Checks to perform: *Check that all the connectors are inserted correctly*

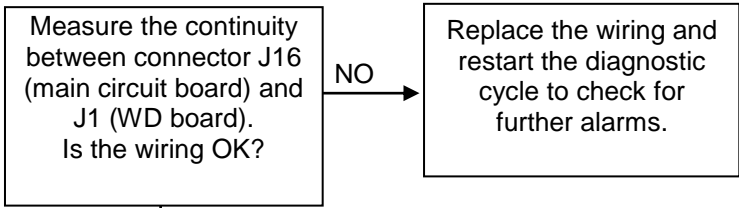

Replace the WD board and restart the diagnostic cycle to check for further alarms.



If the alarm occurs again, replace the main circuit board and repeat the diagnostic cycle to check for any further alarms.

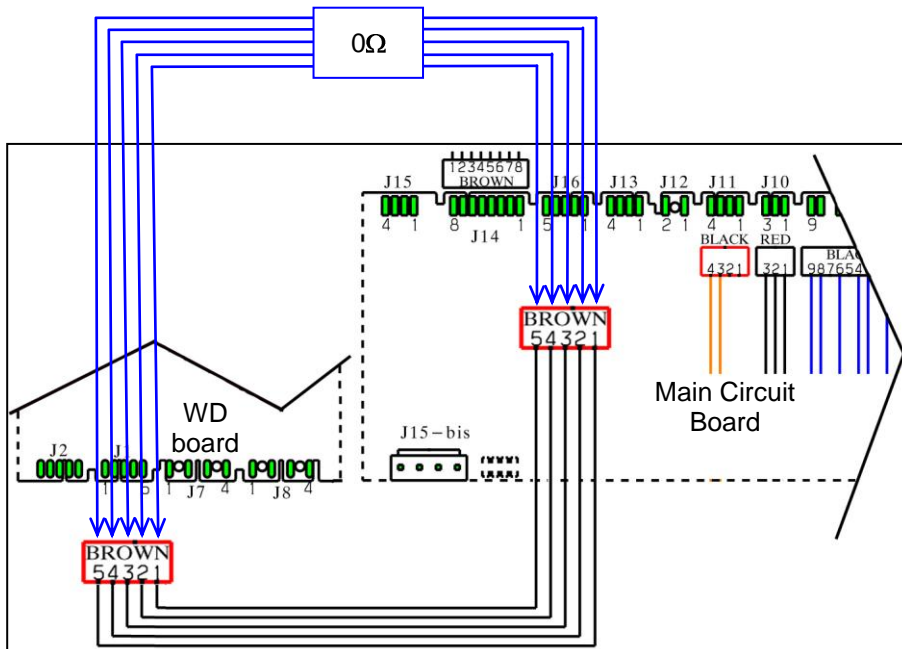

If there are traces of burning on the circuit board, refer to page 94

Checks to perform:

Check that all the connectors are inserted correctly

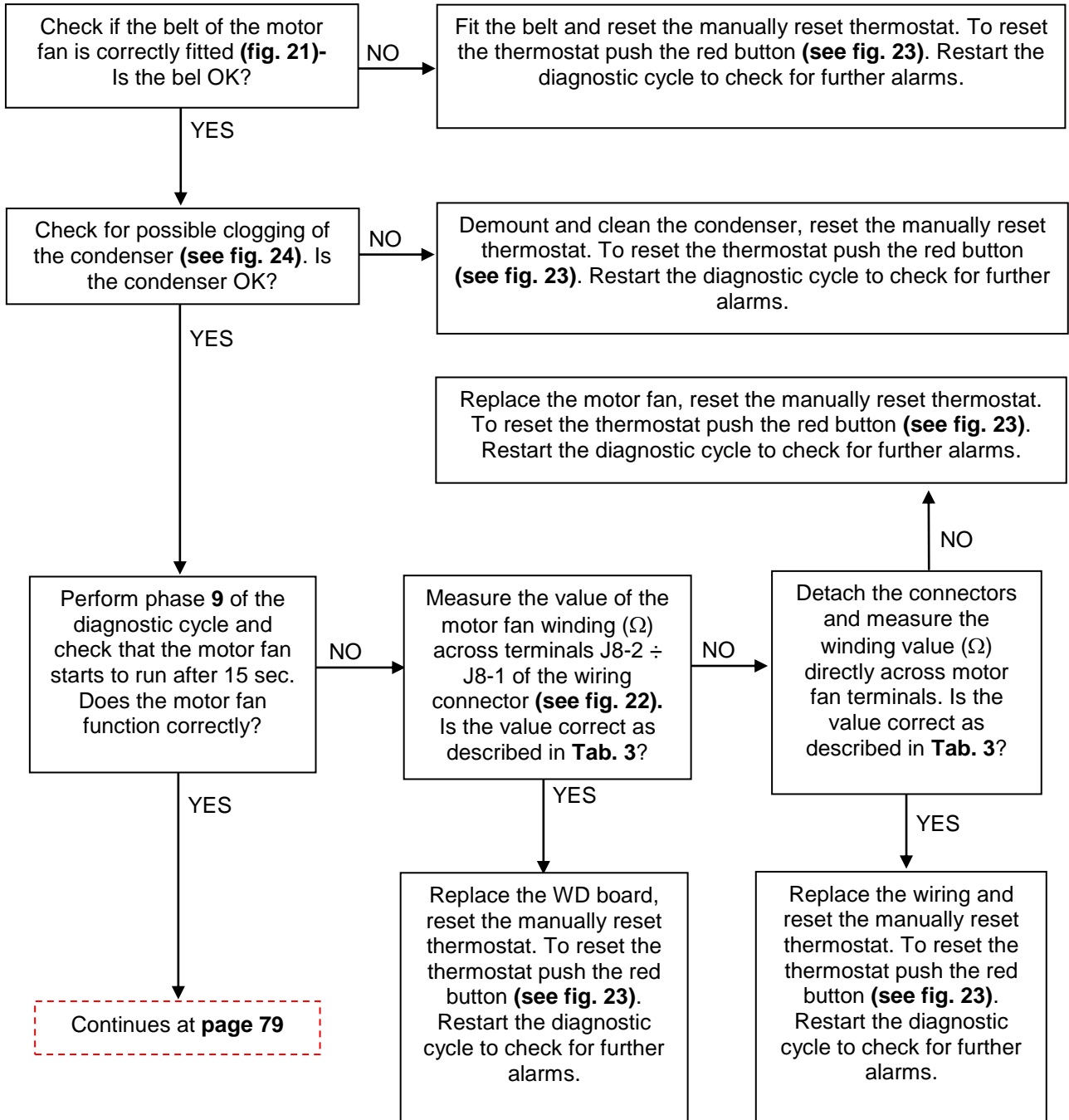

*If there are traces of burning on the
circuit board, refer to page 94*

Follows page 78

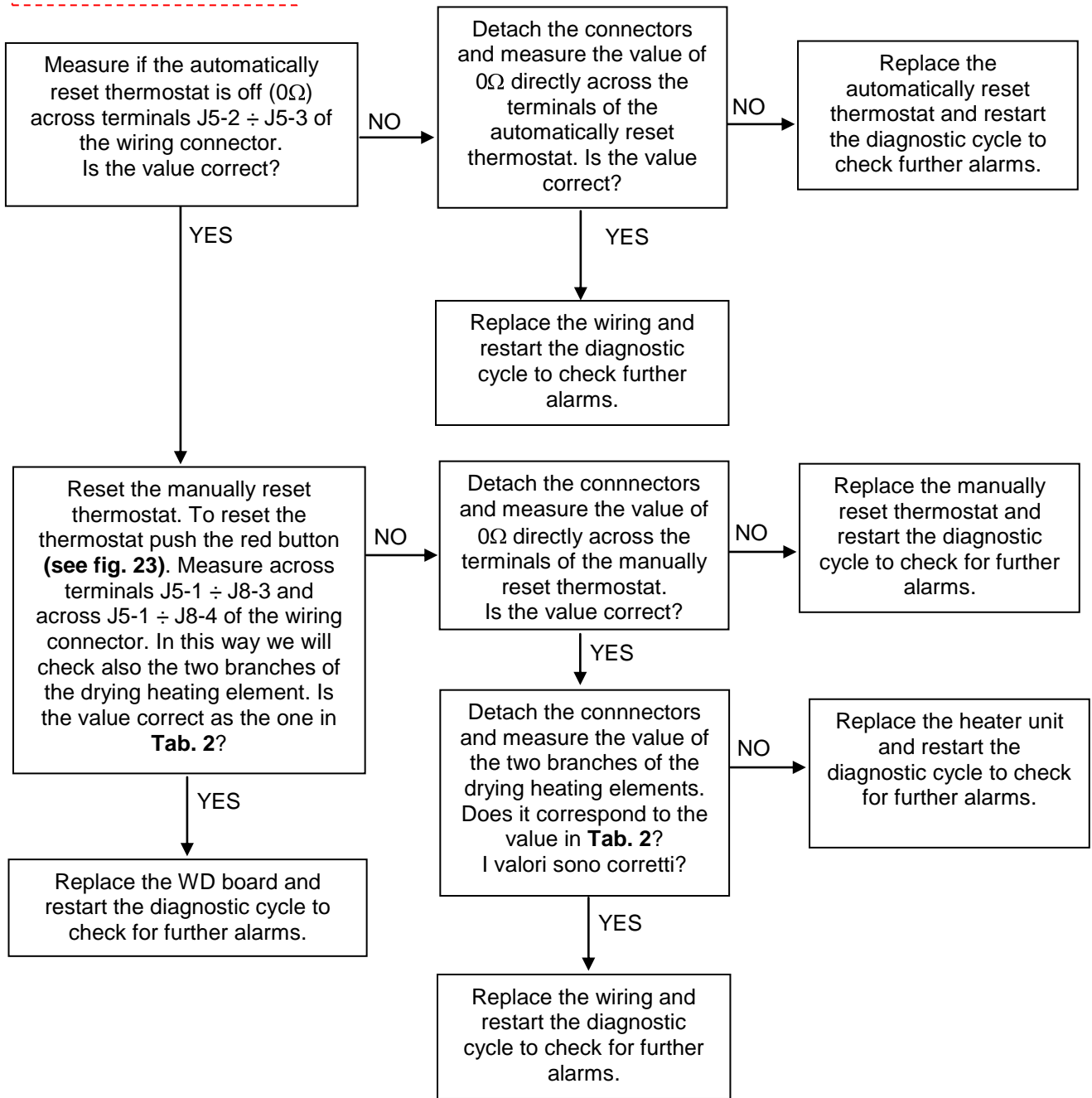

Drying heating element Tab. 2

Branch A
 Across J5-1 and J8-3 measure a value between:
 $51.5\Omega \div 69\Omega$.

Branch B
 Across J5-1 and J8-4 measure a value between:
 $51.5\Omega \div 69\Omega$.

NOTE: The measurements must be carried out with a room temperature of 25°C.

Motor fan Tab. 3

The value of winding heating element is between:
 $22\Omega \div 30.5\Omega$

NOTE: The measurements must be carried out with a room temperature of 25°C.

If there are traces of burning on the circuit board, refer to page 94

ED2

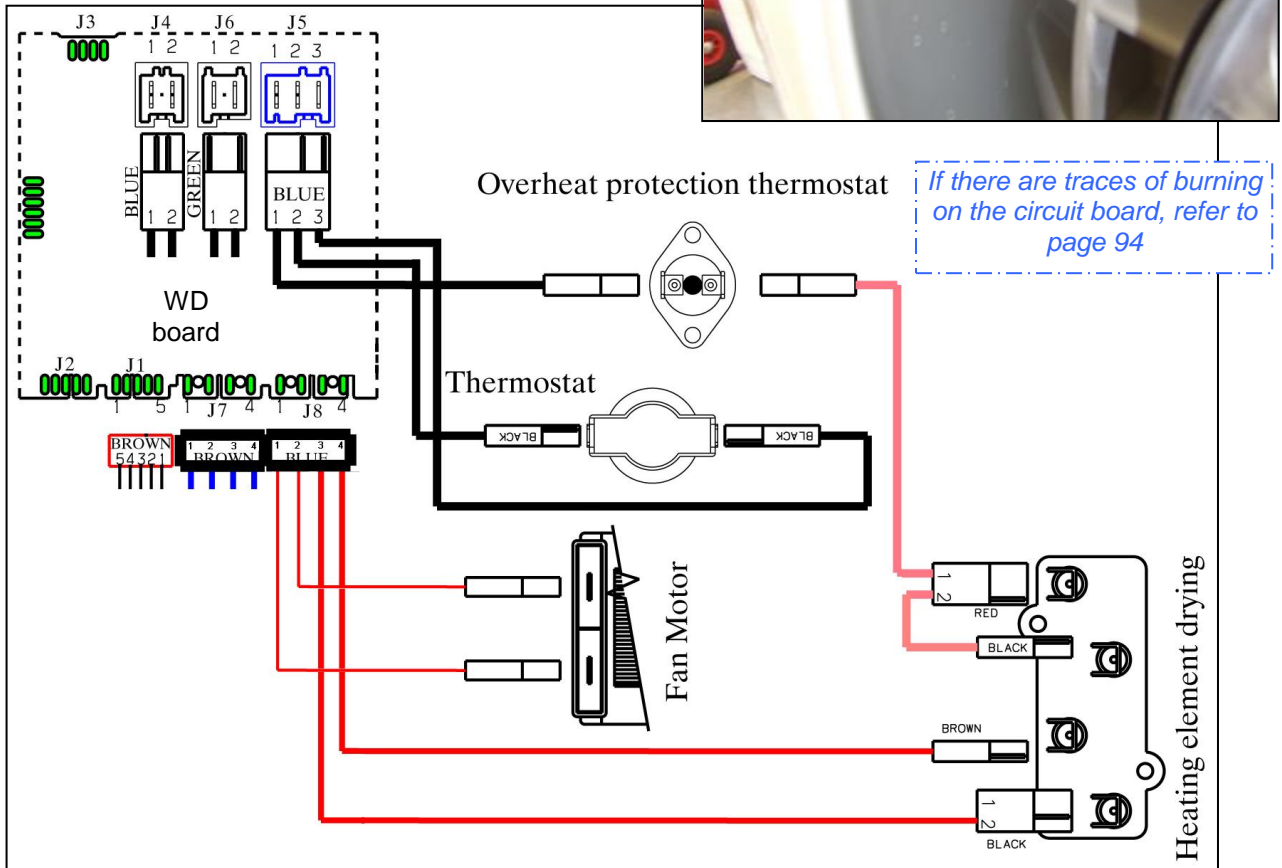
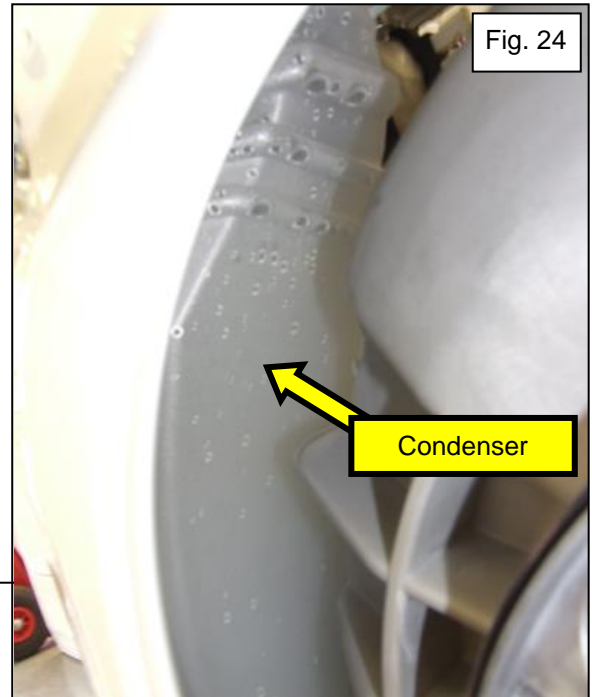
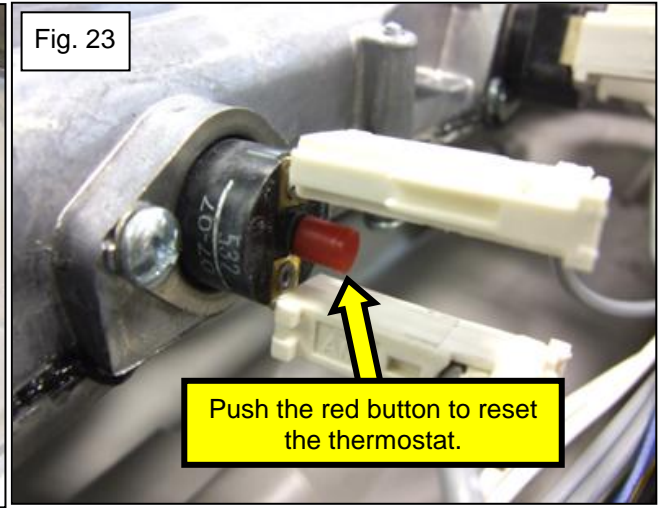
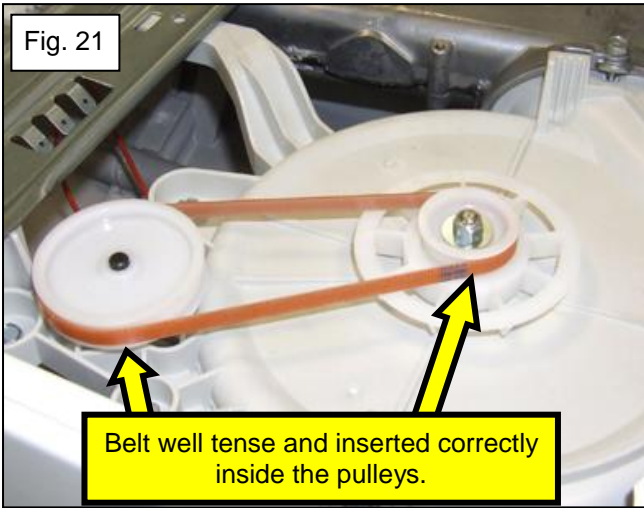

Checks to perform: Check that all the connectors are inserted correctly

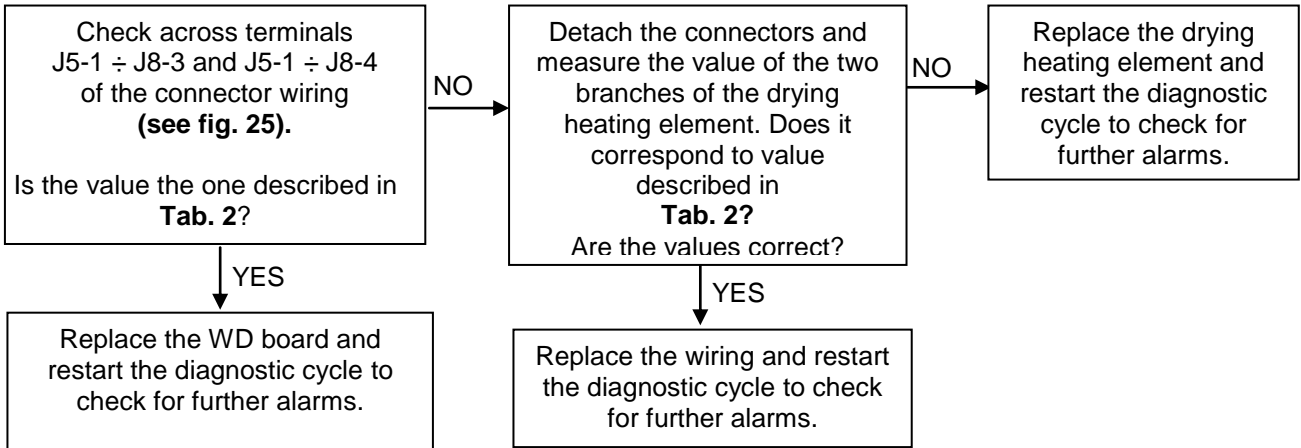

Tab. 2

Drying heating element

Branch A
 Across J5-1 and J8-3 the value must be between:
 51.5Ω and 69Ω.

Branch B
 Across J5-1 and J8-4 the value must be between:
 51.5Ω and 69Ω.

NOTE: The measurements must be carried out with a room temperature of 25°C.

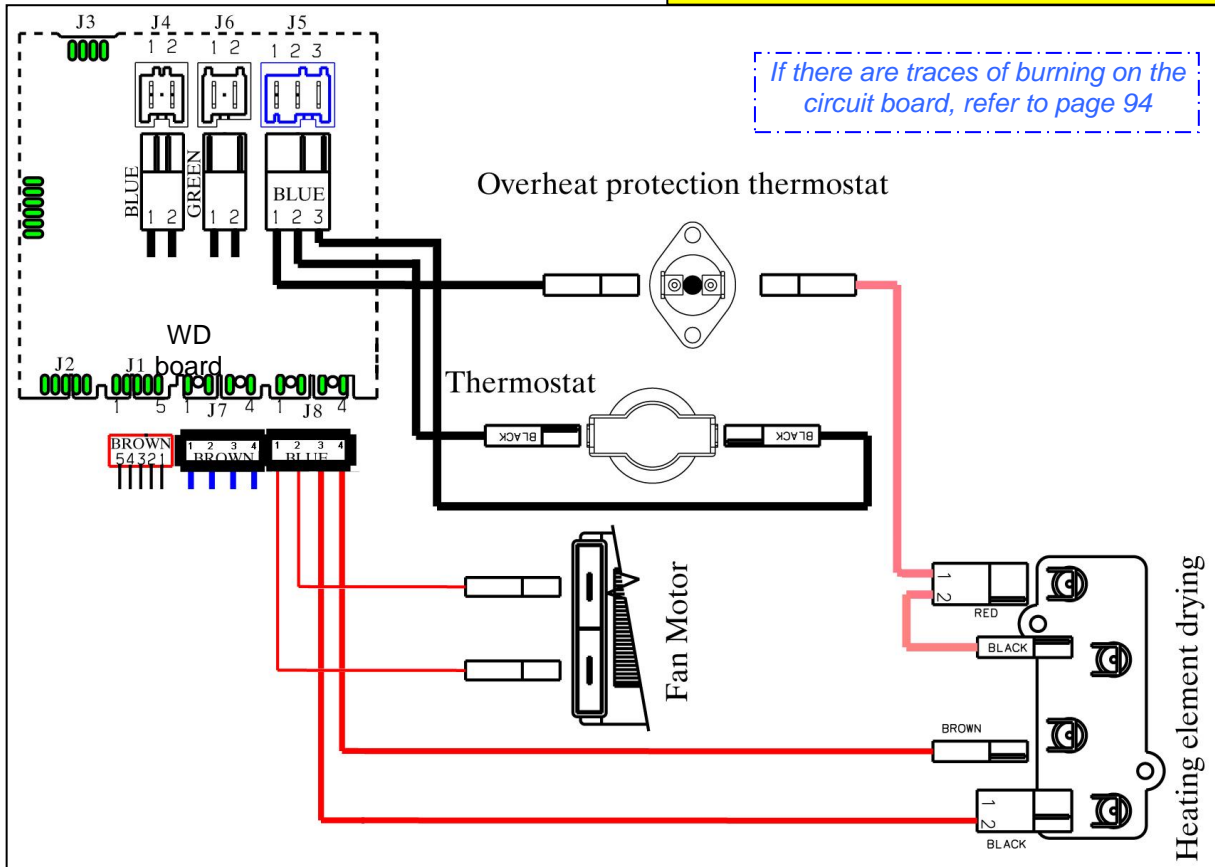

Checks to perform: *Check that all the connectors are inserted correctly*

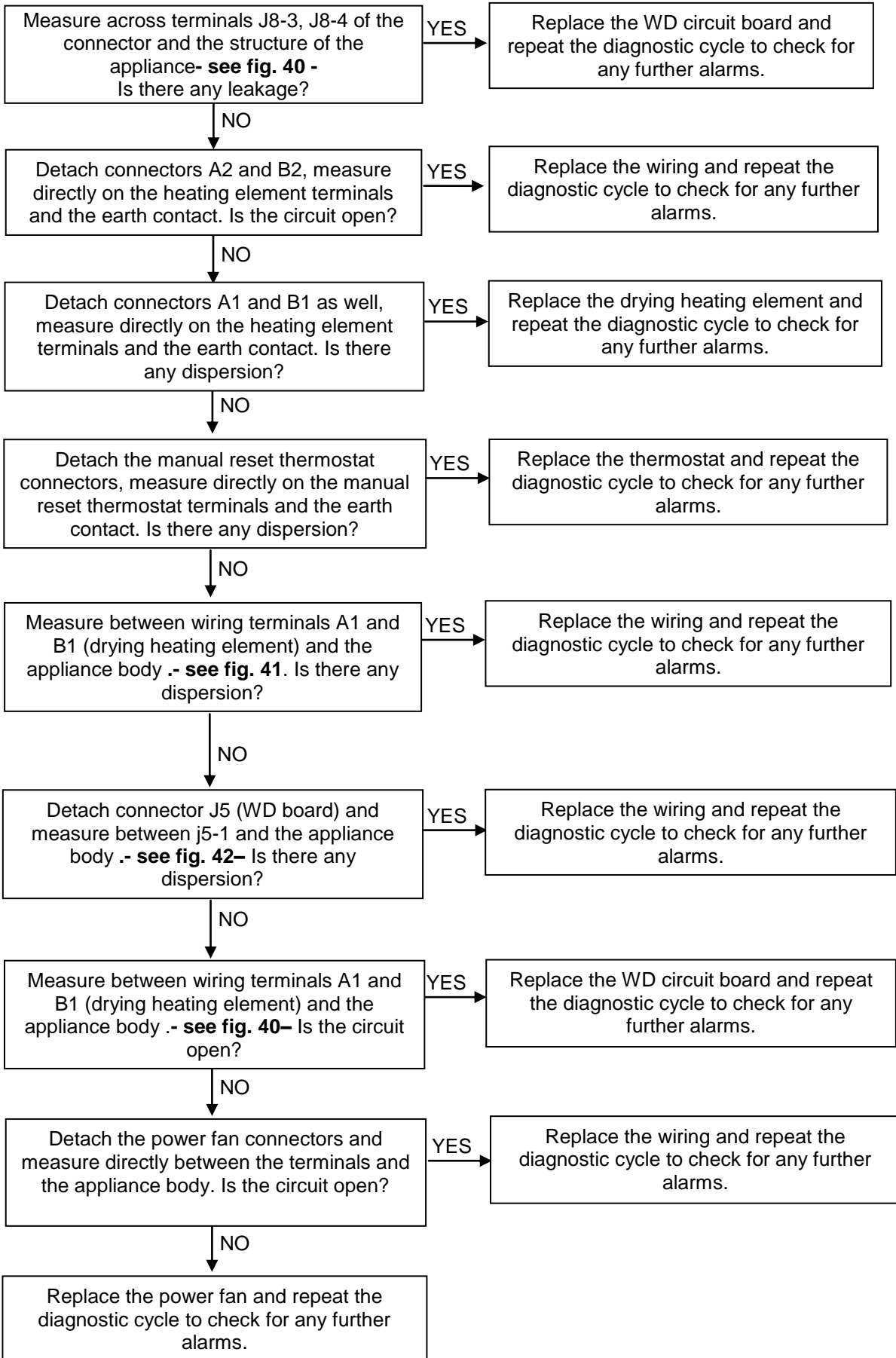

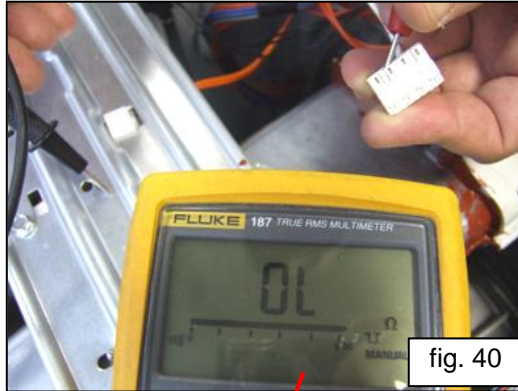

fig. 40

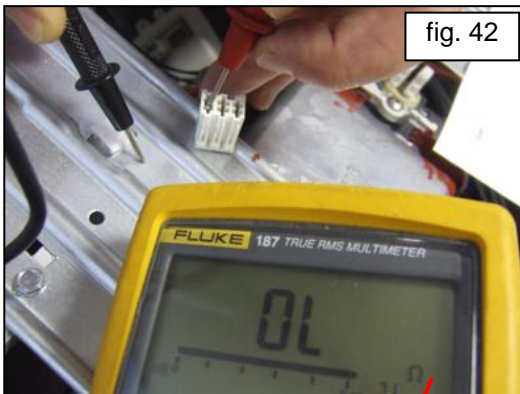

fig. 42

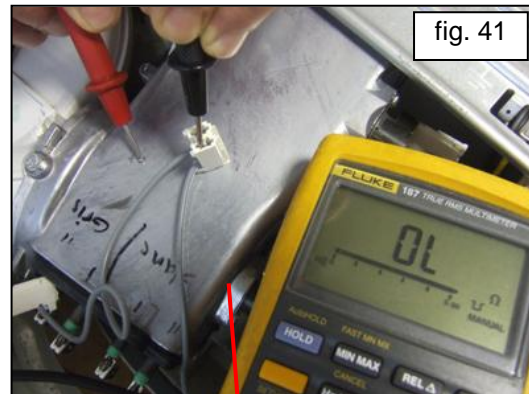
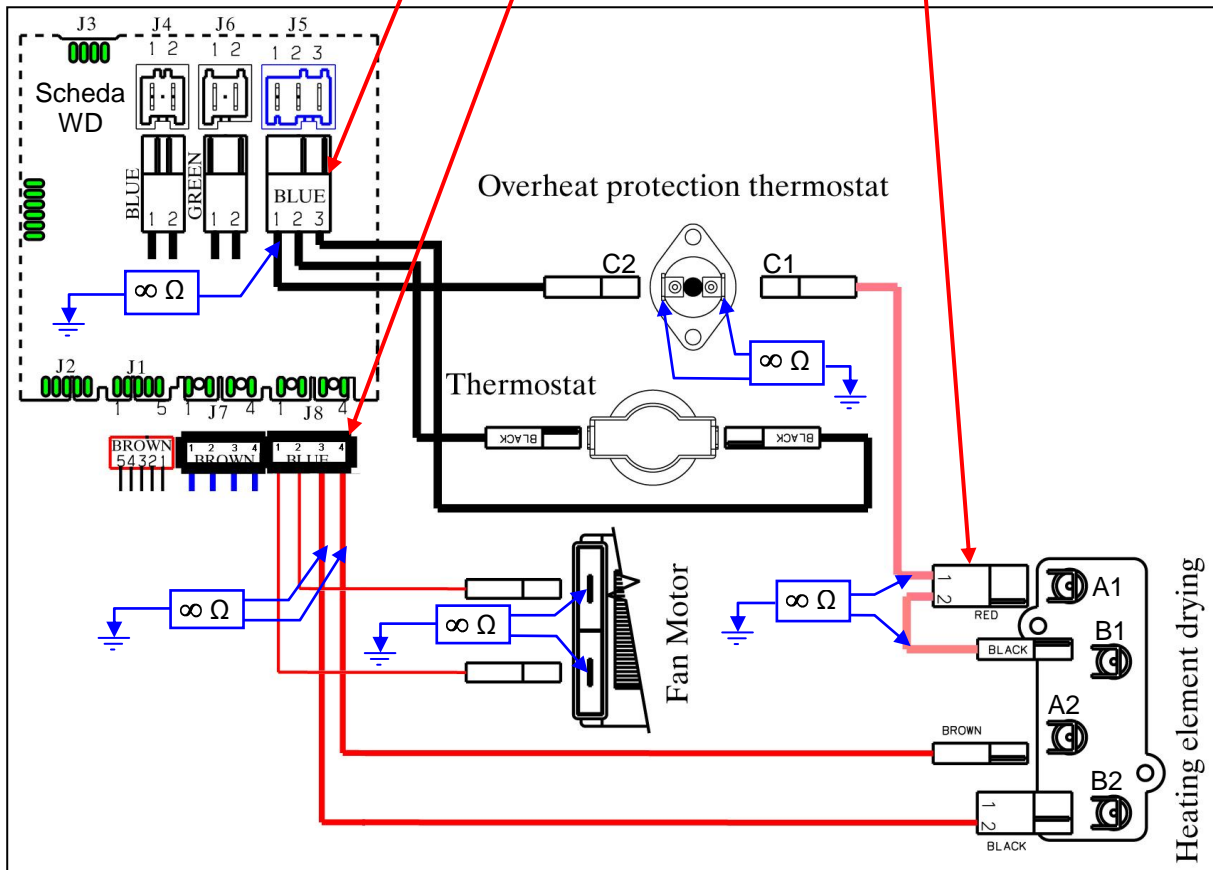

fig. 41



If there are traces of burning on the circuit board, refer to page 94

ED6 ED6: Communication failure between main circuit board and Satellite board (INPUT styling) ED6

Checks to perform: Check that all the connectors are inserted correctly

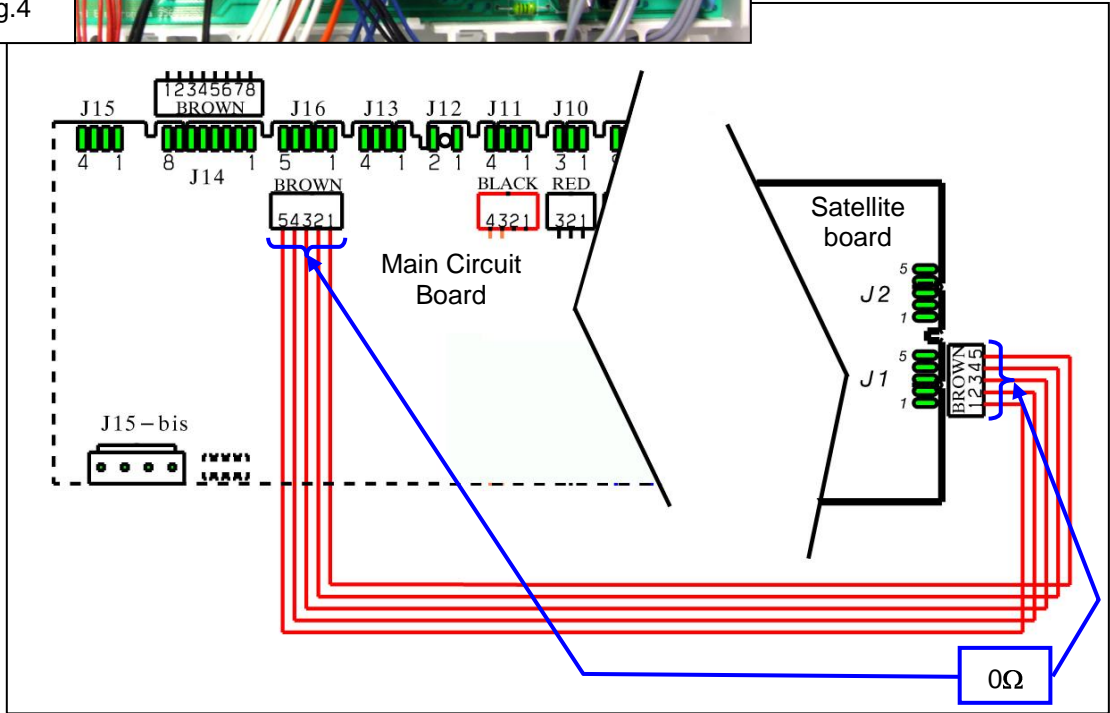
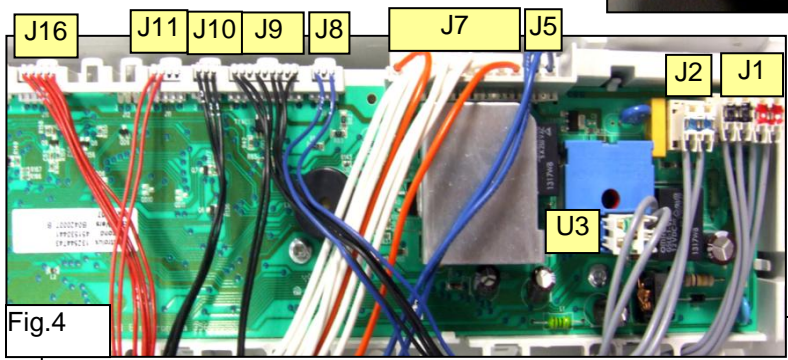
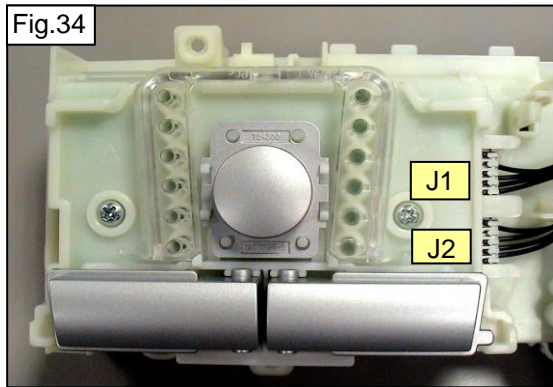
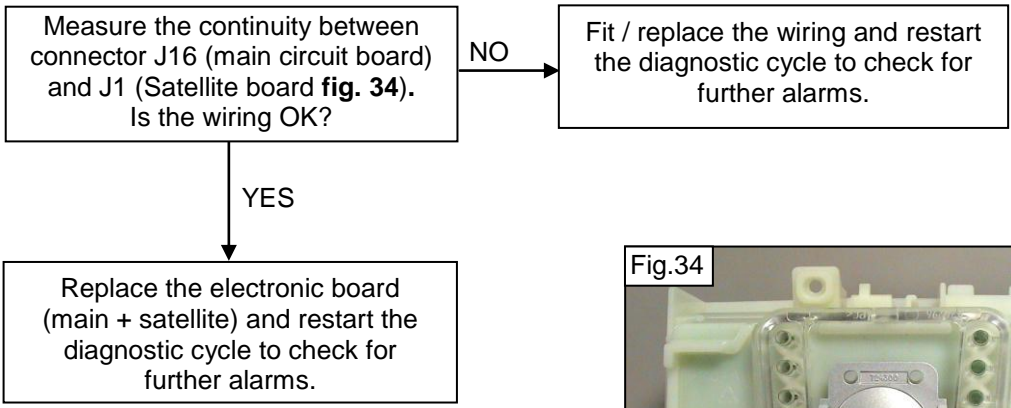

If there are traces of burning on the circuit board, refer to page 94

8.1 Key to circuit diagram WM

Electrical components on appliance	Components on main board	
<ol style="list-style-type: none"> 1. Analogue pressure switch 2. NTC temperature sensor 3. Solenoid valve for prewash 4. Solenoid valve for wash 5. Solenoid valve for bleach 6. Thermal cut-out (circulation pump) 7. Pump circulation 8. Thermal cut-out (drain pump) 9. Drain pump 10. Stator (motor) 11. Rotor (motor) 12. Thermal cut-out (motor) 13. Tachometric generator (motor) 14. Interference filter 15. Instantaneous door interlock 16. Traditional door interlock 17. Heating element (with thermal fuses) 18. Motor with half field 19. Motor without half field 20. Circuit board 21. Drum sensor position (DSP) 22. Flowmeter 23. LCD module 	<p>DOOR_TY DRAIN_TY REC_TY K1 K2 K3 K4 MOTOR_TY ON/OFF PWELW_TY WELV_TY BEL_TY</p>	<p>Door interlock Triac Drain pump Triac Triac circulation pump Heating element relay Motor relay: clockwise rotation Motor relay: anti-clockwise rotation Motor relay: half field power supply (some models) Motor Triac Main switch (programme selector) Pre-wash solenoid Triac Wash solenoid Triac Beach solenoid Triac</p>

9 BASIC CIRCUIT DIAGRAM WM WITH AQUA CONTROL

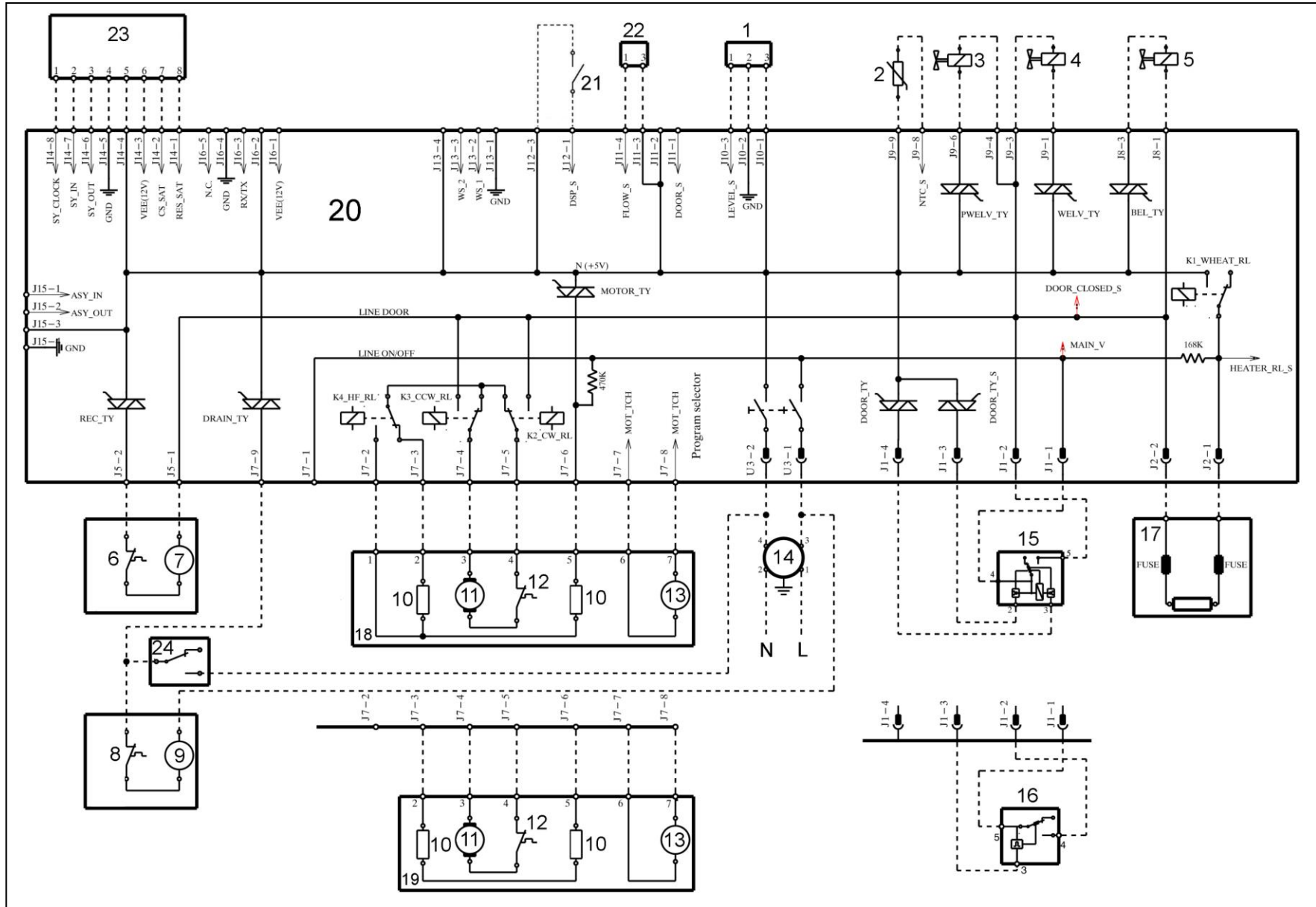

9.1 Key to circuit diagram WM with Aqua Control

Electrical components on appliance	Components on main board	
1. Analogue pressure switch	DOOR_TY	Door interlock Triac
2. NTC temperature sensor	DRAIN_TY	Drain pump Triac
3. Solenoid valve for prewash	REC_TY	Triac circulation pump
4. Solenoid valve for wash	K1	Heating element relay
5. Solenoid valve for bleach	K2	Motor relay: clockwise rotation
6. Thermal cut-out (circulation pump)	K3	Motor relay: anti-clockwise rotation
7. Pump circulation	K4	Motor relay: half field power supply (some models)
8. Thermal cut-out (drain pump)	MOTOR_TY	Motor Triac
9. Drain pump	ON/OFF	Main switch (programme selector)
10. Stator (motor)	PWELW_TY	Pre-wash solenoid Triac
11. Rotor (motor)	WELV_TY	Wash solenoid Triac
12. Thermal cut-out (motor)	BEL_TY	Beach solenoid Triac
13. Tachometric generator (motor)		
14. Interference filter		
15. Instantaneous door interlock		
16. Traditional door interlock		
17. Heating element (with thermal fuses)		
18. Motor with half field		
19. Motor without half field		
20. Circuit board		
21. Drum sensor position (DSP)		
22. Flowmeter		
23. LCD module		
24. Aqua Control (water leaks device)		

10 BASIC CIRCUIT DIAGRAM WD

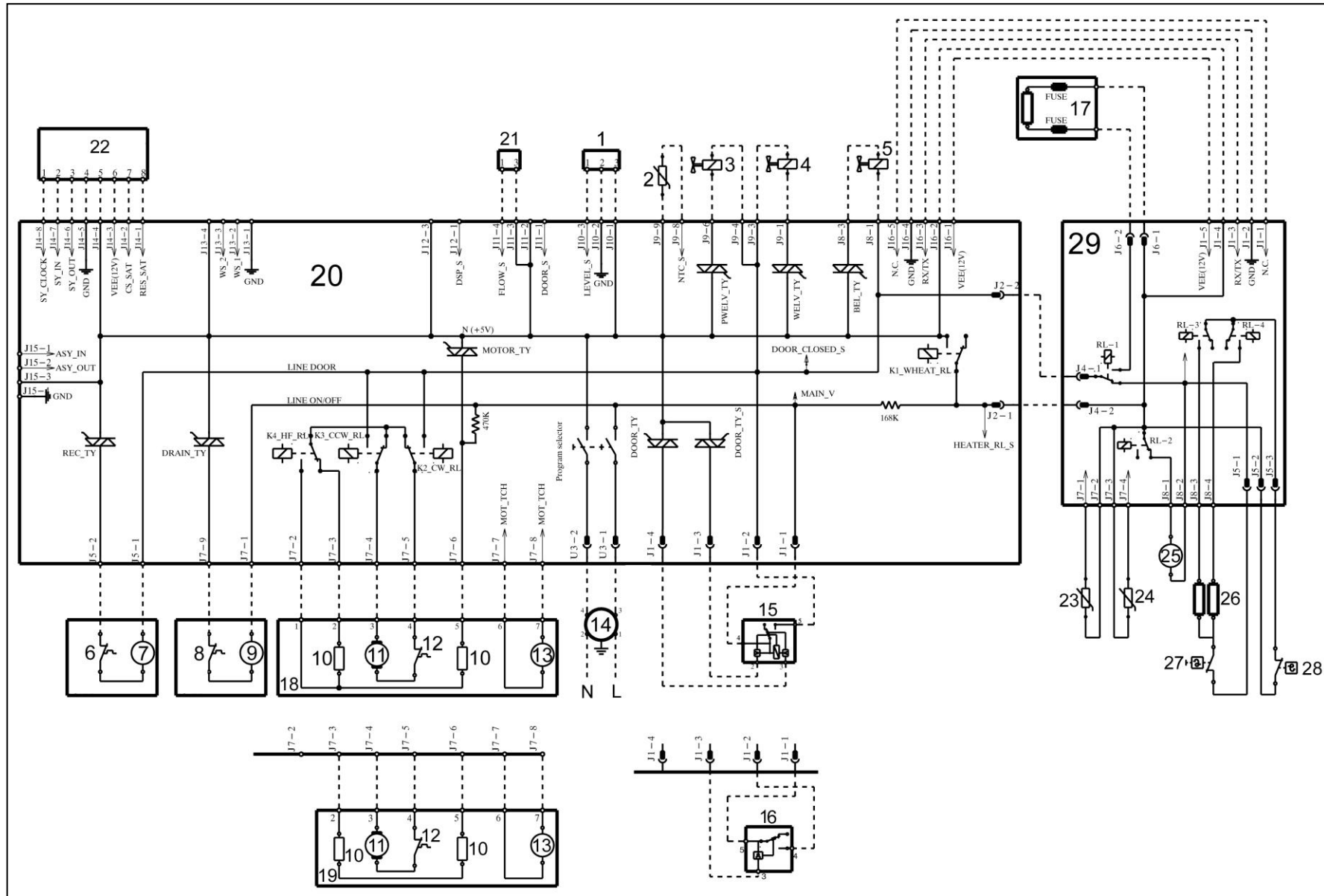

10.1 Key to circuit diagram WD

Electrical components on appliance	Components on main board	
1. Analogue pressure switch	DOOR_TY	Door interlock Triac
2. NTC temperature sensor	DRAIN_TY	Drain pump Triac
3. Solenoid valve for prewash	REC_TY	Triac circulation pump
4. Solenoid valve for wash	K1	Heating element relay
5. Condensation solenoid valve	K2	Motor relay: clockwise rotation
6. Thermal cut-out (circulation pump)	K3	Motor relay: anti-clockwise rotation
7. Pump circulation	K4	Motor relay: half field power supply (some models)
8. Thermal cut-out (drain pump)	MOTOR_TY	Motor Triac
9. Drain pump	ON/OFF	Main switch (programme selector)
10. Stator (motor)	PWELW_TY	Pre-wash solenoid Triac
11. Rotor (motor)	WELV_TY	Wash solenoid Triac
12. Thermal cut-out (motor)	BEL_TY	Beach solenoid Triac
13. Tachometric generator (motor)		
14. Interference filter		
15. Instantaneous door interlock		
16. Traditional door interlock		
17. Heating element (with thermal fuses)		
18. Motor with half field		
19. Motor without half field		
20. Circuit board		
21. Flowmeter		
22. LCD Module		
23. Humidity temperature sensor		
24. Drying temperature sensor		
25. Motor fan		
26. Drying heating elements		
27. Manually reset thermostat		
28. Automatically reset thermostat		
29. WD board		

11 BASIC CIRCUIT DIAGRAM WD WITH AQUA CONTROL

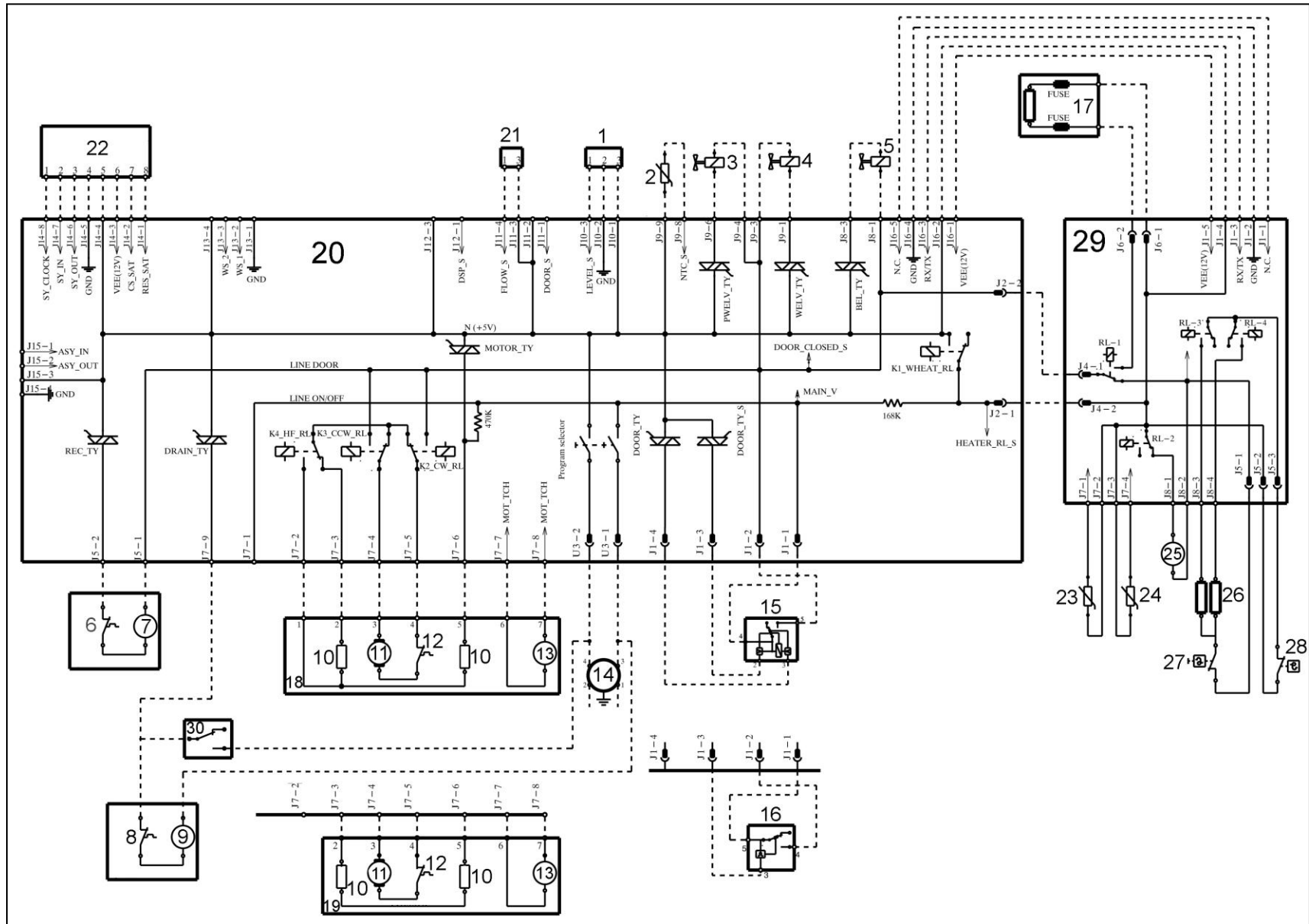

11.1 Key to circuit diagram WD with aqua control

Electrical components on appliance	Components on main board	
1. Analogue pressure switch	DOOR_TY	Door interlock Triac
2. NTC temperature sensor	DRAIN_TY	Drain pump Triac
3. Solenoid valve for prewash	REC_TY	Triac circulation pump
4. Solenoid valve for wash	K1	Heating element relay
5. Condensation solenoid valve	K2	Motor relay: clockwise rotation
6. Thermal cut-out (circulation pump)	K3	Motor relay: anti-clockwise rotation
7. Pump circulation	K4	Motor relay: half field power supply (some models)
8. Thermal cut-out (drain pump)	MOTOR_TY	Motor Triac
9. Drain pump	ON/OFF	Main switch (programme selector)
10. Stator (motor)	PWELW_TY	Pre-wash solenoid Triac
11. Rotor (motor)	WELV_TY	Wash solenoid Triac
12. Thermal cut-out (motor)	BEL_TY	Beach solenoid Triac
13. Tachometric generator (motor)		
14. Interference filter		
15. Instantaneous door interlock		
16. Traditional door interlock		
17. Heating element (with thermal fuses)		
18. Motor with half field		
19. Motor without half field		
20. Circuit board		
21. Flowmeter		
22. LCD Module		
23. Humidity temperature sensor		
24. Drying temperature sensor		
25. Motor fan		
26. Drying heating elements		
27. Manually reset thermostat		
28. Automatically reset thermostat		
29. WD board		
30. Aqua Control (water leaks device)		

12 CONNECTORS ON CIRCUIT BOARD WM/WD

J15/J15B	J16	J11	J9	J7	J1
Serial interface: J15-1 ASY_IN J15-2 ASY_OUT J15-3 +5V J15-4 GND	Communication with WD external board: J16-1 Vee 12V J16-2 5V J16-3 Rx/Tx J16-4 GND J16-5 N.C.	J11-3 Flowmeter (GND) J11-4 Flowmeter (signal)	J9-1 Washing solenoid (triac) J9-3 Solenoids (line) J9-4 Solenoids (line) J9-6 Pre-wash solenoid (triac) J9-8 NTC temperature sensor J9-9 NTC temperature sensor	J7-1 Drain pump (line) J7-2 Motor (stator - ½ field) J7-3 Motor (stator full field) J7-4 Motor (rotor) J7-5 Motor (rotor) J7-6 Motor (triac) J7-7 Motor (tachometric generator) J7-8 Motor (tachometric generator) J7-9 Drain pump (triac)	J1-1 Door safety interlock (triac) J1-2 Door safety interlock (line-sensing) J1-3 Door safety interlock (line)
J14	J12	J10	J8	J5	U3
LCD Module: J14-1 RES_SAT J14-2 CS_SAT J14-3 Vee (12V) J14-4 GND J14-5 5V J14-6 SY_OUT J14-7 SY_IN J14-8 SY_CLOCK	J12-1 Drum position sensor DSP (sensing) J12-2 not used J12-3 Drum position sensor DSP (+5V)	J10-1 Analogic pressure switch (+5V) J10-2 Analogic pressure switch (GND) J10-3 Analogic pressure switch (signal)	J8-1 Bleach/condensation solenoid J8-3 Bleach/condensation solenoid (tiac)	J5-1 Circulation pump (line) J5-2 Circulation pump (triac)	U3-1 Line U3-2 Line (neutral)
				J2	
				J2-1 Heating element (relay) J2-2 Heating element (line)	

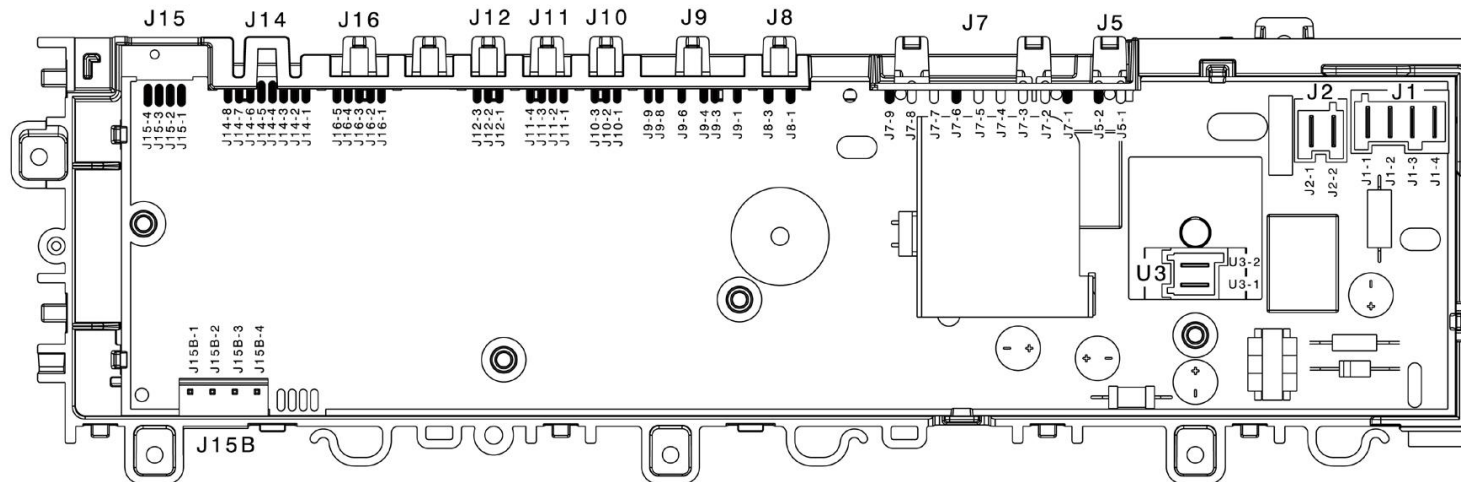

13 BURNING ON THE CIRCUIT BOARD EWM2100 WM/WD

In case of burning on the main circuit board, check that the problem is not caused by another electrical component (short-circuits, poor insulation, water leakage). Refer to the figures below in order to identify the component that might have caused the burning according to the position of the burned area.

The circuit board shown below is the version with the greatest number of components: other boards may not feature all these components.

<ol style="list-style-type: none"> 1. Power supply 2. Motor 3. Heating element 4. Drain pump 5. Door safety interlock 	<ol style="list-style-type: none"> 6. Tachometric generator (motor) 7. Water fill solenoids 8. NTC temperature sensor washing 9. Analogic sensor 10. Drum positioning (top-loader) 	<ol style="list-style-type: none"> 11. Flowmeter 12. Circulation pump 13. Communication WD board 14. Communication LCD
--	---	--

14 APPENDIX

Revision	Date	Description
01	06/03/2009	Modified Alarms E21-E22 page 17 / Alarm EF3 page 75
02	07/2010	<ul style="list-style-type: none"> - Added control panels on pages 6/7 - Added hot water in position 5 on page 11 - Deleted two sentences in the paragraph "Rapid reading of alarms" page 16 - The sentence: "Checks to perform" has been replaced with "Checks to perform Check that all the connectors are correctly inserted." On every page - Alarm EF3 on page 75: the words " and if the intervention is caused by overheating of the water drain pump: check for any objects that might be blocking the normal functioning of the pump rotor" have been restored. - Changed alarms Ed1 on page 77 - Changed Ed4 radically on page 82
03	01/2013	<ul style="list-style-type: none"> - Added one control panel on page 7 - Added Eb0 on page 13 - Added b is represented by 11 flashes (appliances with LEDs) on page 15 - Added H is represented by 11 flashes (appliances with LCD / DISPLAY) on page 15 - Corrected paragraph number from 4.2 to 5.2 on page 16 - Added complete row for alarms E9b/E9H to the alarms table on page 19 - Added Eb1-Eb2-Eb3 to the alarms table on page 19 - Added a note at the end of the table on page 20: * See page 15