

© Electrolux Distriparts GmbH
Muggenhofer Straße 135
D-90429 Nürnberg
Germany

Publ.-Nr.:
599 52 93 05
685
EN

Fax +49 911 323 1022

DGS-TDS-N
Edition 07.08

**Washing machines,
Toploader**

**LCD-appliance
EWM 3500**

**ENV 06
Serie 8**

AEG

CONTENTS

Control Panel / Multifunctionsdisplay LCD	3		
Push Buttons / Functions and settings of the appliance	4	-	20
Programselector / Programme	21	-	22
Buzzer / Extra rinse cycle	23		
Functions of the System	24		
Connection electronic	25		
Electronic Module	26		
Loudspeaker	27		
Door Lock	28		
DSP Function (Drum Self Position)	29		
Float switch / Inlet valve with flow-meter-sensor	30		
Water Inlet Valve for 3-chamber detergent box	31		
Water Distributor	32		
Analogic pressure switch	33		
Heating element	34		
Heating Circuit	35		
Drain pump / Circulation pump	36		
Motor / Motor control board	36		
Drum movements / Spin Profiles	37	-	39
Function of the FUCS	40	-	41
Foam Detection	42		
Service Program	43	-	51
Demo Program	52		
Electronictest Program	53		
Operating time	54		
Circuit Diagram	55	-	57
Program	58	-	64
Changes	65		

Control Panel

Version Serie 8 (Premium-design)

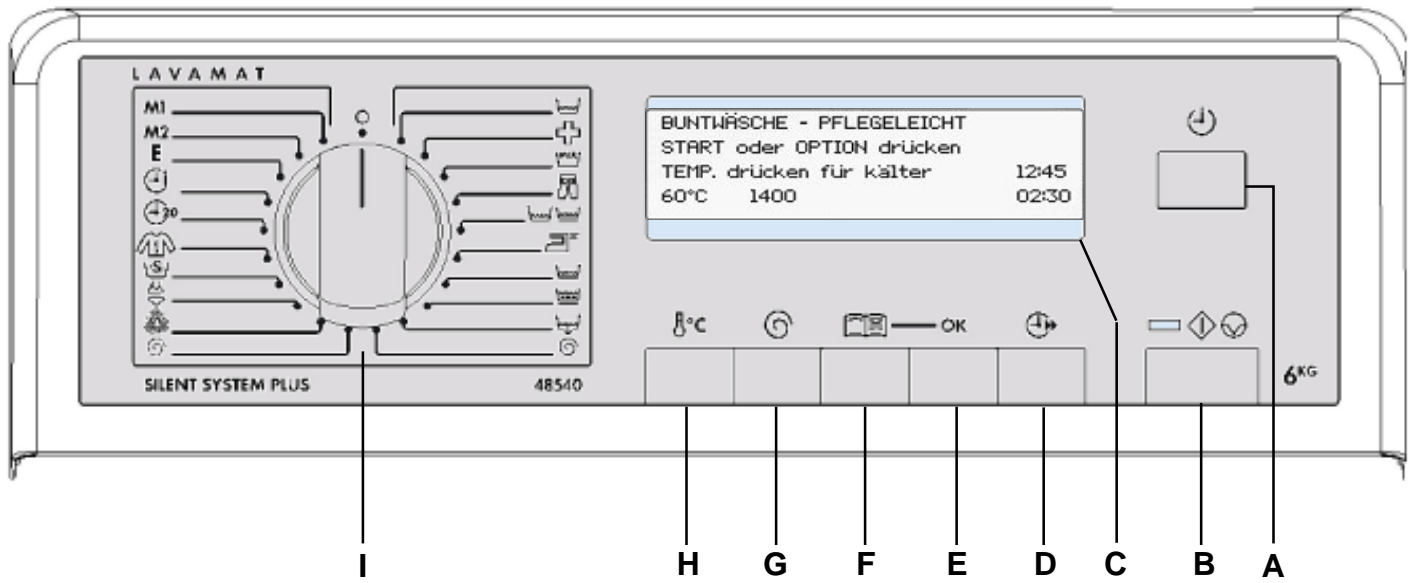

- | | |
|------------------------------------|--------------------------|
| A Delayed start | F Option |
| B Start, Pause | G Spin |
| C Multifunktionsdisplay LCD | H Temperature |
| D Quick | I Programselector |
| E Ok | |

Multifunktionsdisplay LCD

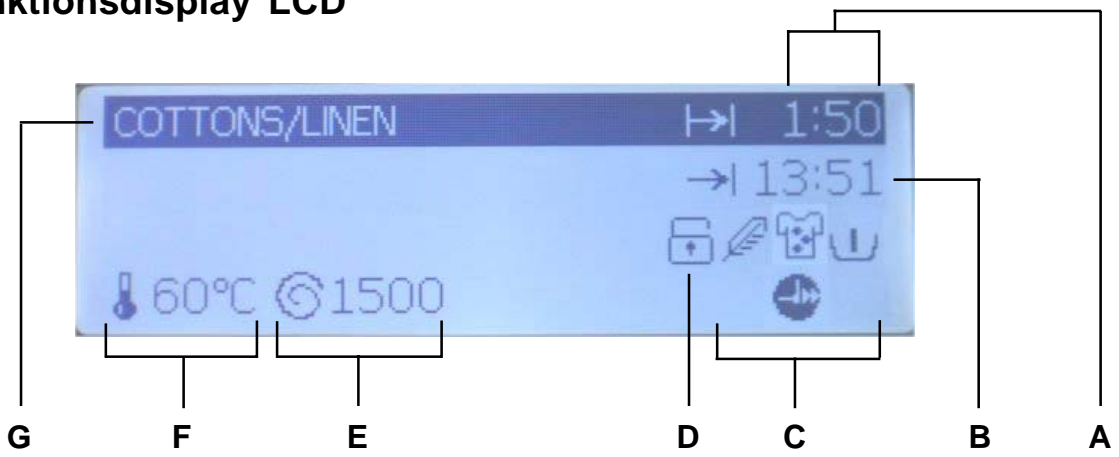

- | | |
|----------------------------|----------------------------------|
| A Cycle time / Time | E Spin deselection |
| B Cycle end | F Temperature deselection |
| C Options | G Program |
| D Child safety | |

Push Buttons / Functions and settings of the appliance

Start/Pause button

Funktion:

- By the START/PAUSE key you can start a selected program, or if necessary, to stop it in order to add laundry.
- When a program has been stopped, the appliance first tries to position the drum.
- Afterwards the door lock will be released.

- Program is running in the main cycle.
- Press the START/PAUSE key.



- Program is stopped, the drum is positioned.



- The drum is positioned.
- The door lock is unlocked.
- The appliance is in the PAUSE mode.



- In order to continue the wash cycle, press the START/PAUSE key. The cycle will be continued where it had been stopped.

Cycles

- The wash cycle is divided into 8 phases.
- Fill, Heating, Wash (Prewash), Rinse, Drain, Spin, the drum positioned. and End (lid open).
- With any washing phase it indicates the phase name, program run time and probable program end.

1. Filling



2. Heating



3. Mainwash (Prewash)



4. Rinse



5. Drain



6. Spin



7. the drum positioned



8. End (Main lid unlocked)



Standby

Function:

- After 10 minutes of standby in the pre-selection position or at the end of the cycle, the light of the Display switches off and the LED Start/Pause flashes slowly. (all 5 sec.)
Pressing any button or rotating the selector, the appliance returns to the normal status (following model MCF-file).

Interrupt a washing cycle / Cancel a washing cycle

Function:

- To stop a running wash cycle completely, you have to turn off the program selector to OFF position.
- The wash cycle is stopped without positioning the drum.

- Program is running in the main cycle.

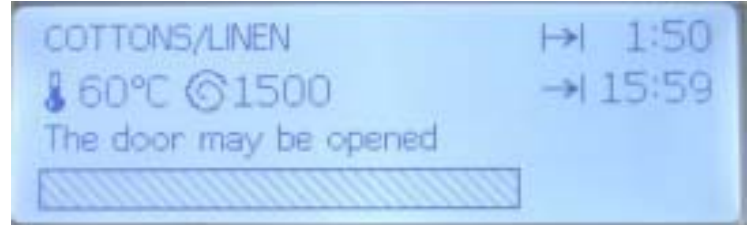

- Press the START/PAUSE key



- Set the program selector to OFF position.
- Program is stopped.



- Select the washing program anew.
- In order to continue the wash cycle press the START/PAUSE key. To stop the wash cycle press the OK key.

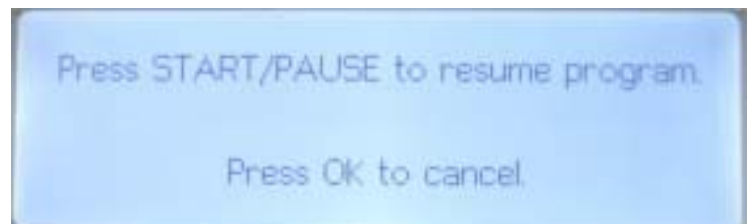

Ok button

Function:

- By the OK/SET key you can register and save the selected options.

Spin deselection button

Function:

- By pressing this key, you can reduce spin-dry speed step by step down to night cycle or to rinse hold.
- Reduces the spinning speed of all spin-dry cycles.

1500	1400	1200	1000	800	600	400	Night Cycle	Rinse hold
	1400	1200	1000	800	600	400	Night Cycle	Rinse hold
	1300	1200	1000	800	600	400	Night Cycle	Rinse hold
		1200	1000	800	600	400	Night Cycle	Rinse hold
			900	800	600	400	Night Cycle	Rinse hold
				700	600	400	Night Cycle	Rinse hold

- A corresponding symbol is indicated depending on the selected speed.
- Night cycle- and Rinse hold-Symbol



Temperature button

Function:

- To activate the temperature button it is necessary to select a program.
- By pushing this button the washing temperature can be reduced to 0°C step-by-step.

adjust temperature	95°C	60°C	50°C	40°C	30°C	0°C
--------------------	------	------	------	------	------	-----

- A corresponding symbol is indicated depending on the selected temperature.
- The temperature is indicated in degree Celsius.



Delayed start-key

Function:

- The start time can be selected max. from 0h, 30', 60', 90', 2h - 20h.
- The start time is counted down minutes by minutes.
- Change of delayed start:
 - Press the START/PAUSE key.
 - Change the delayed start, press the DELAYED START key.
 - Press the START/PAUSE key.

Cancel start time:

- Set the program selector to OFF position.
- Select washing cycle again.
- Press the OK key.

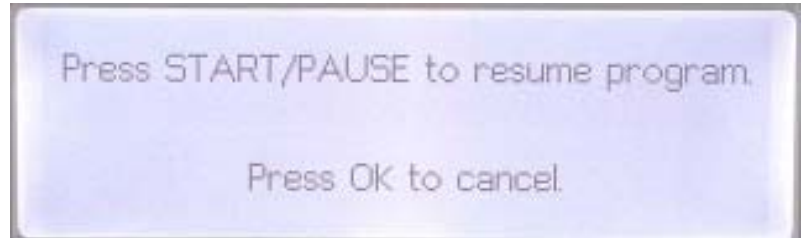

Enter start time:

- Select a washing program.

Program run time: 01:50
Program end: 17:58



- Enter the start time by the DELAYED START key

Program run time: 01:50
Program end: 21:58



- Press the START/PAUSE key.

Delayed Start: 04:00
Program end: 21:58



Quick-key

Function:

- The program running time can be shortened by pressing the time saving button 2x.
a.e. **cotton/coloureds 60°**

- **cotton/coloureds 60°**
1h 50min

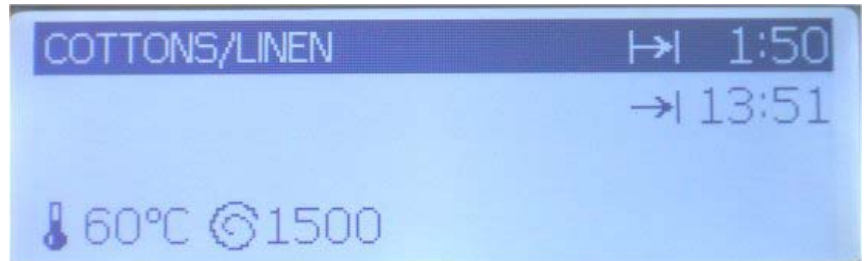

- **cotton/coloureds 60°**
+ 1x Quick-key
1h 40min



- **cotton/coloureds 60°**
+ 2x Quick-key
0h 45min

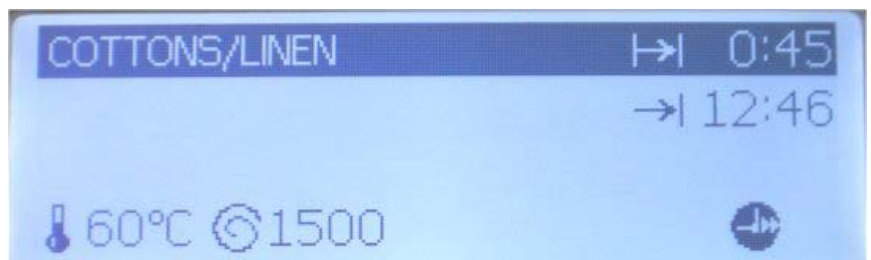

Option - and Option + button

Function:

- By both option keys you can call and select other sub-functions.

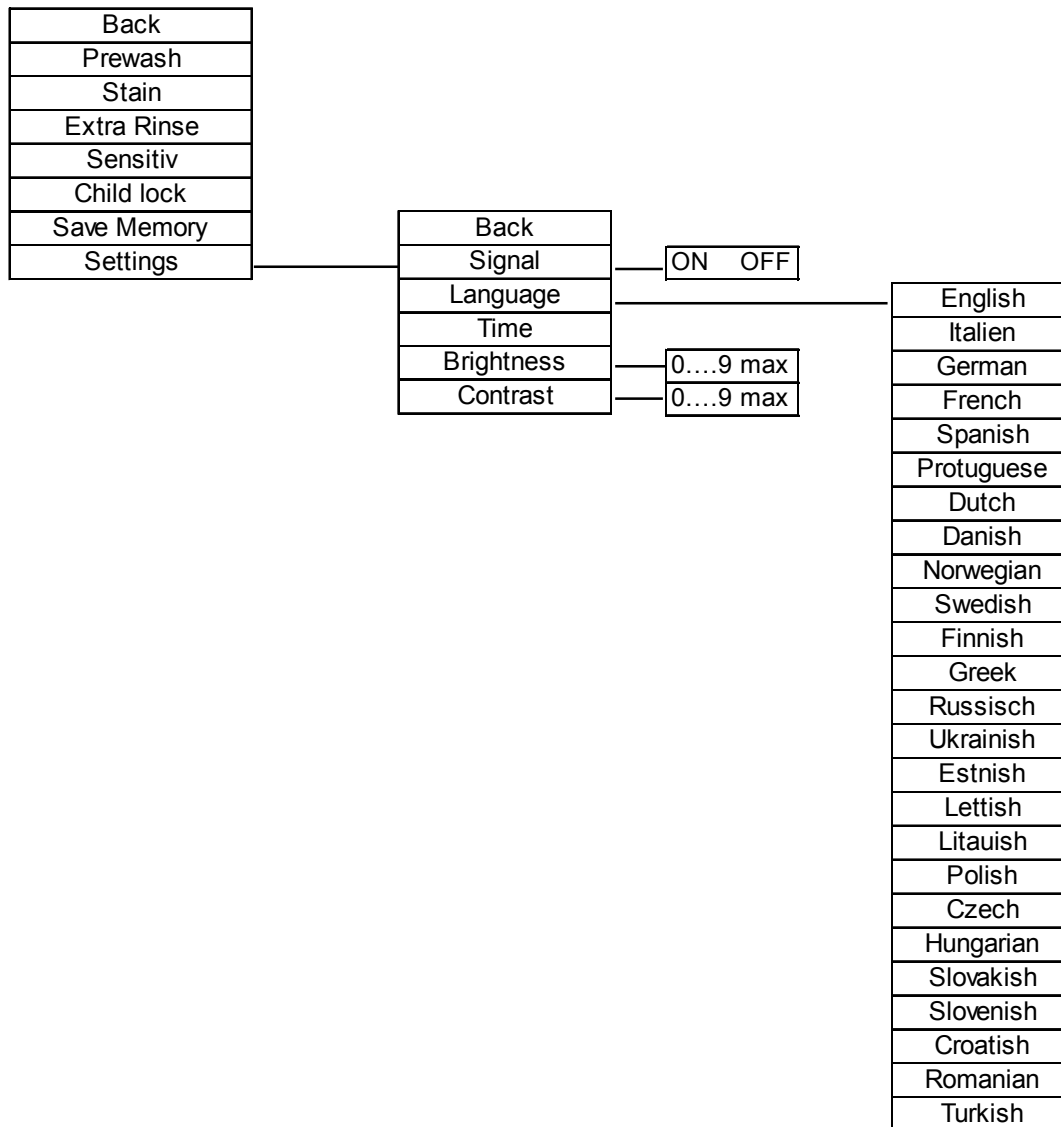

Child safety

Function:

- The child safety function can be activated at the start of the program and also after the program has started. When the child safety lock has been activated, it is not possible to modify the running wash cycle by the program selector.

- Press the OPTION key until the CHILD SAFETY function will appear.
- Press the OK key.



- The child safety lock has been activated.



- The option is activated, the initiated wash program runs normally through and on completion any further function of the appliance is disabled. The option remains saved when the appliance is turned off.

- Switch on the appliance
- By pressing the key combination repeatedly it is possible to deactivate the child safety lock again or by pressing both keys OPTION and OK simultaneously for approximately 5 sec.



Save Memory

Function:

- When the given washing programs are modified, another temperature, another spin speed or with different additional options, you can save these washing programs in “Memory” position on the program selector.

- Select the washing program with the modified options.



- Press the OPTION key until the SAVE MEMORY function will appear.



- After 2 sec you can see a program assistant.
- Press the OK key.

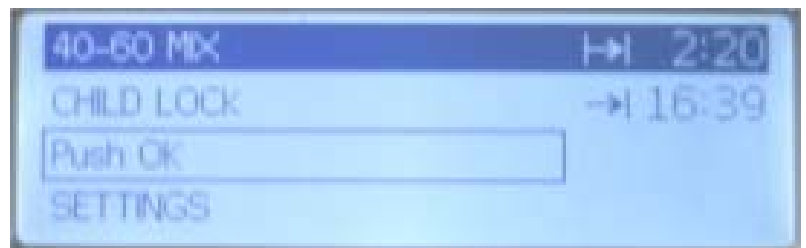

- Select the desired memory location by using the OPTION key.
- Press the OK key.



- The selected program was saved in the free memory location.
- After approx. 2 sec the display indicates again the saved program.



Modify Memory

Function:

- When all memory locations "Memory" are occupied, it is also possible to modify them again. As described under point Washing Program Favorite, you can select New Program and the SAVE MEMORY function.

- Select the memory location.
- Press the OK key.



- When the memory location shall be modified, press the OK key.
- When the memory location shall not be modified, press the OPTION key.

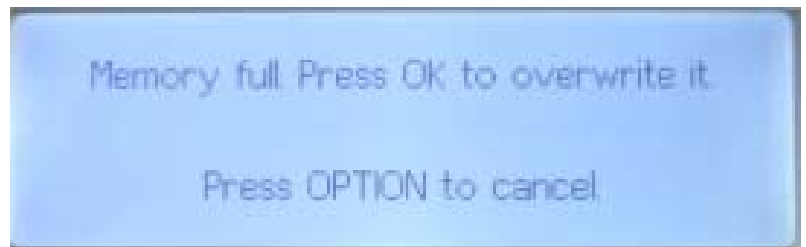

- The memory location was overwritten with the new program.
- After approx. 2 sec the display indicates again the saved program.



Settings

Function:

- By using the SETTINGS function you can modify the following parameters. Language, contrast, brightness, time and sound (volume).
- Select a washing program.
- Press the OPTION key until the SETTINGS function will appear.
- After 2 sec you can see a program assistant.
- Press the OK key.



Signal

Function:

- Press the OPTION key until the SIGNAL function will appear.
- After 2 sec you can see a program assistant.
- Press the OK key.
- By the OPTION key you can start or stop the signal function.
- Press the OK key.
- By pressing one of the keys like temperature, spinning, start or OK or after a waiting period of approx. 10 sec., the normal program mode is activated again.



Language

Function:

- Select a washing program.
- Press the OPTION key until the LANGUAGE function will appear.

- After 2 sec you can see a program assistant.
- Press the OK key.

- Press the OPTION key until you can see the desired language.
- Pressing the OK key saves the language.

- By pressing one of the keys like temperature, spinning, start or OK or after a waiting period of approx. 10 sec., the normal program mode is activated again.

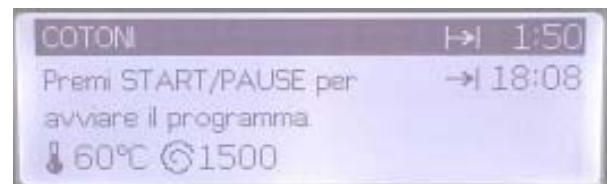
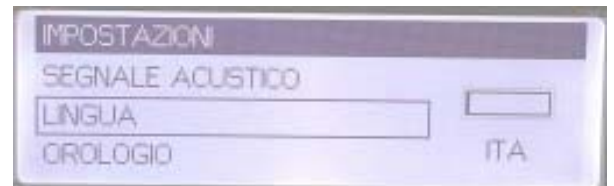

Clock

Function:

- Press the OPTION key until the CLOCK function will appear.

- After 2 sec you can see a program assistant.
- Press the OK key.

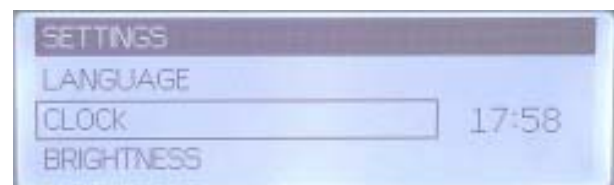

- Hour indication is sparkling.
- Press the OPTION key until you can see the desired HOUR.
- Press the OK key.
- Minute indication is sparkling.
- Push the OPTION key until you can see the desired minutes.
- By pressing the OK key the clock will be saved.



- By pressing one of the keys like temperature, spinning, start or OK or after a waiting period of approx. 10 sec., the normal program mode is activated again.



Brightness

Function:

- Select a washing program.
- Press the OPTION key until the BRIGHTNESS function will appear.

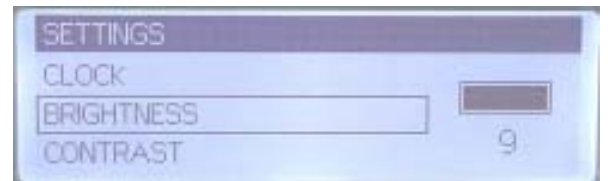

- After 2 sec you can see a program assistant.
- Press the OK key.

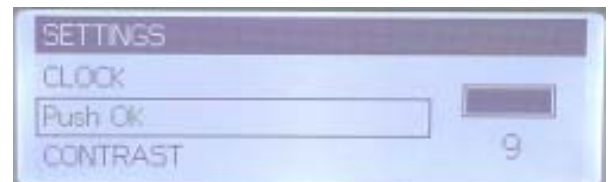

- Press the OPTION key until you can see the desired brightness.
- You can select ten different brightness from 0 MIN ... 9 MAX.
- By pressing the OK key the brightness will be saved.

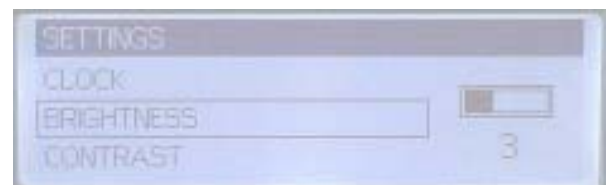

- By pressing one of the keys like temperature, spinning, start or OK or after a waiting period of approx. 10 sec., the normal program mode is activated again.

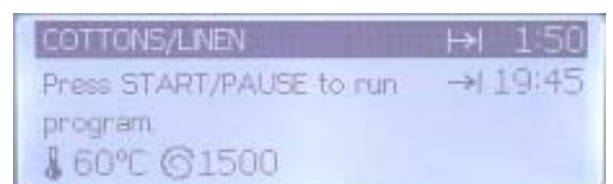

Contrast

Function:

- Select a washing program.
- Press the OPTION key until the CONTRAST function will appear.
- After 2 sec you can see a program assistant.
- Press the OK key.
- Press the OPTION key until you can see the desired contrast.
- You can select ten different contrasts from 0 MIN ... 9 MAX.
- By pressing the OK key the contrast will be saved.
- By pressing one of the keys like temperature, spinning, start or OK or after a waiting period of approx. 10 sec., the normal program mode is activated again.

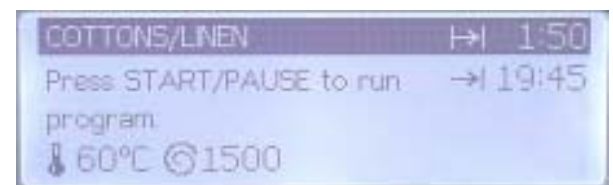
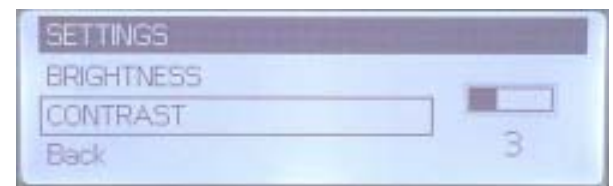
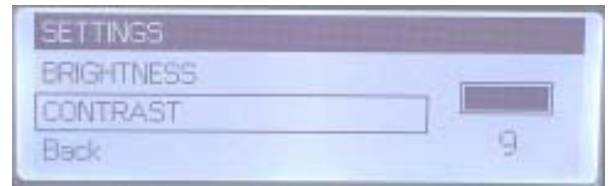

Options

The selection of the options is to be carried out after switching on the appliance and setting the desired programme with the selector and before pressing the start/pause button.

Programmes		Options																
		Rinse-hold	Night cycle	Pre-wash	Stains	Bleach	Extra rinse	Easy iron	Eco	Intensiv	Normal	Daily	Light	Quick	Super quick	Reduced spin speed	no spin	Half-load
Compatibility with programmes	Cotton	90°C	X	X	X	X	X	X	X	X	X	X	X	X	X	X	X	X
		60°C	X	X	X	X	X	X	X	X	X	X	X	X	X	X	X	X
		50°C	X	X	X	X	X	X	X	X	X	X	X	X	X	X	X	X
		40°C	X	X	X	X	X	X	X	X	X	X	X	X	X	X	X	X
		30°C	X	X	X		X	X	X		X	X	X	X	X	X	X	X
	cold	X	X	X		X	X	X		X	X	X	X	X	X	X	X	
	Synthetic	60°C	X	X	X	X	X	X		X	X	X		X	X	X		
		50°C	X	X	X	X	X	X		X	X	X		X	X	X		
		40°C	X	X	X	X	X	X		X	X	X		X	X	X		
		30°C	X	X	X		X	X		X	X	X		X	X	X		
		cold	X	X	X		X	X		X	X	X		X	X	X		
	Delicates	40°C	X	X	X	X	X			X	X	X		X	X	X		
		30°C	X	X	X		X			X	X	X		X	X	X		
		cold	X	X	X		X			X	X	X		X	X	X		
	Wool	40°C	X	X							X					X		
		30°C	X	X							X					X		
		cold	X	X							X					X		
	Easy iron	60°C	X		X		X	X		X					X	X		
		50°C	X		X		X	X		X					X	X		
		40°C	X		X		X	X		X					X	X		
		30°C	X		X		X	X		X					X	X		
	Blanket	40°C	X		X		X	X		X					X	X		
		30°C	X		X		X	X		X					X	X		
		60°C	X	X	X		X	X		X					X	X		
		50°C	X	X	X		X	X		X					X	X		
	Jeans	40°C	X	X	X		X	X		X					X	X		
		30°C	X	X	X		X	X		X					X	X		
		cold	X	X	X		X	X		X					X	X		
		40°C	X	X	X		X			X					X			
	Shoes	30°C	X	X	X		X			X					X			
		cold	X	X	X		X			X					X			
		40°C	X	X						X					X	X		
	Lingerie	30°C	X	X						X					X	X		
		cold	X	X						X					X	X		
		30°C	X	X											X	X	X	
	Silk	cold	X	X											X	X	X	
		40°C	X	X	X		X			X					X	X		
	Baby, Sport intensiv	30°C	X	X	X		X			X					X	X		
		cold	X	X	X		X			X					X	X		
		30°C	X	X	X		X			X					X	X	X	
	Sport light, Mi	30°C	X	X	X	X	X			X					X	X	X	
	Sanitär	90°C	X	X	X	X	X			X					X	X	X	
	5 Shorts	30°C	X	X	X	X	X			X					X	X		
	MIX 40°-60°	40°C	X	X	X	X	X		X						X	X	X	
	Hygiene +	90°C	X	X		X	X	X		X					X	X	X	
		60°C	X	X		X	X	X		X					X	X	X	
		50°C	X	X		X	X	X		X					X	X	X	
		40°C	X	X		X	X	X		X					X	X	X	
	Gras	60°C	X	X	X	X	X	X		X					X	X		
		50°C	X	X	X	X	X	X		X					X	X		
40°C		X	X	X	X	X	X		X					X	X			
Express	60°C	X				X								X	X			
Sensitiv Plus	60°C	X	X	X	X	X				X		X		X	X			
Quick	30°C	X								X				X				
Soak	30°C			X						X								
Rinses		X	X			X	X	X							X	X		
softener		X	X			X									X	X		
Conditioner		X	X				X								X	X		
Drain																		
Spin															X			
Gentle spin															X			

Function:



Rince hold

- The program is finish with water in the drum.
- In order to continue a program afterwards, you first have to select a separate draining or spinning.

Function:



Night Cycle

- The number of rinces are increase cotton/cotoured from three rinces to six rinces and synthetic from three rinces to four rinces.
- All rinces are without a spinphase.
- The programm is stopped in a rinse hold.
- In order to continue a program afterwards, you first have to select a separate draining or spinning.
- Switches off the buzzer (if configured)

Function:



Pre-Wash

- It is heated up to max. 30 ° C.
- Can't be combined with the programe wool, silk and sport 30.

Function:



Stains

- The selected temperature however must be $\geq 40^{\circ}\text{C}$.
- Separate rinsing in of stain remover through the pre-wash chamber, approx. 1.2 ltrs.
- Can't be combined with the pre-wash function.
- Extends the cycle duration in the main wash by 5 minutes after the first heating to 40°C .

Function:



Extra rinse

- Two additional rinse cycles are added in the cycle cotton / coloured.
- One additional rinse cycle are added in the cycles synthetics, delicate fabrics and silk.
- No intermediate rinse, except after the last rinse cycle.

Function:



Easy Iron 40°

With **cotton/coloureds** programmes:

- No intermediate spin-dry cycle.
- 3 additional rinse cycles.
- Pulse spin-dry
- Additional loosening phase after spin-drying

With **synthetics** programmes:

- Reduced wash temperature
- Prolonged wash time and prolonged cooling phase
- One additional rinse cycle
- Additional loosening phase after spin-drying

Function:



Energy Saving

- The washing temperature in the programs:
E90°C is reduced to 67°C, the max. temperature kept constantly for a certain period of time.
E60°C is reduced to 40°C, the max. temperature kept constantly for a certain period of time.
E40°C is reduced to 40°C, the max. temperature achieved for a short moment.
- Can't be combined with the quick function.

Programselector

Depending on the model, the electronic may include a programselector with 21-positions.

The programselector includes the “on/off” function and the wash programs.



Programme

Jeans



Function:

- The cycle includes a main cycle, five rinse cycles. (1. and 2. rinses without intermediate spins and 3., 4., 5. rinses with intermediate spins max.1200 1/min).
- The load amount is 3kg.
- Can be combined with the Night Cycle Pre-wash and Spin deselection button.

Shoes 30°, 40°



Function:

- The program consists of a main wash, three rinses without intermediate spins but with an end spin. (1000 1/min).
- It is heated up to 40 °C.
- Can be combined with the Quick, Extra rinse, Night Cycle, Pre-wash, Soaking and Spin deselection button.

Silk 30°



Function:

- The program consists of a main wash, three rinses without intermediate spins but with an end spin. (700 1/min).
- Washing time during main wash is 10 min.
- The load amount is 1kg.

Baby 30°, 40°



Function:

- The program consists of a main wash, three rinses with higher water levels without intermediate spins, but with an end spin. (700 1/min).
- The load amount is 2kg.

Sanitär 90°



Function:

- The program consists of a main wash, three rinses with intermediate spins but with an end spin. (1200 1/min).
- Washing temperature during main wash is kept constantly to 85° for 10 min.
- The load amount is 5,5kg.

Dessous 30°, 40°



Function:

- The program consists of a main wash, three rinses without intermediate spins but with an end spin. (900 1/min).
- The load amount is 1Kg.

Blanket 30°, 40°



Function:

- The program consists of a main wash, three rinses with higher water levels (20ltr.) intermediate and end spin. (650 1/min).
- The load amount is 2,5kg.

Soak



Function:

- The soaking period begins with pre-wash and soaks for about the next 30 minutes.
- Can't be combined with the function pre-wash.
- It is heated up to 30 °C.
- A short spin cycle is performed in the cycles COTTON and SYNTHETICS, before passing on to the main wash.
- You can prolong soaking time for max. 0h, 30', 60', 90', 2h - 10 h using the „Start preset“ key.
- After pressing the start key, the duration of the cycle is displayed by hours and minutes.

Sport light 30°



Function:

- The program consists of a main wash, two rinses with higher water levels without intermediate spins, but with an end spin. (700 1/min).
- The load amount is 2kg.

Sport intensiv 30°, 40°



Function:

- The cycle consists of prewash, higher water level, heating to 30° and spin cycle to 650 1/min, one main wash, two rinse cycles without intermediate spin with higher water level but with final spin (900 1/min).
- The load amount is 2,5kg.

Buzzer / Extra rinse cycle

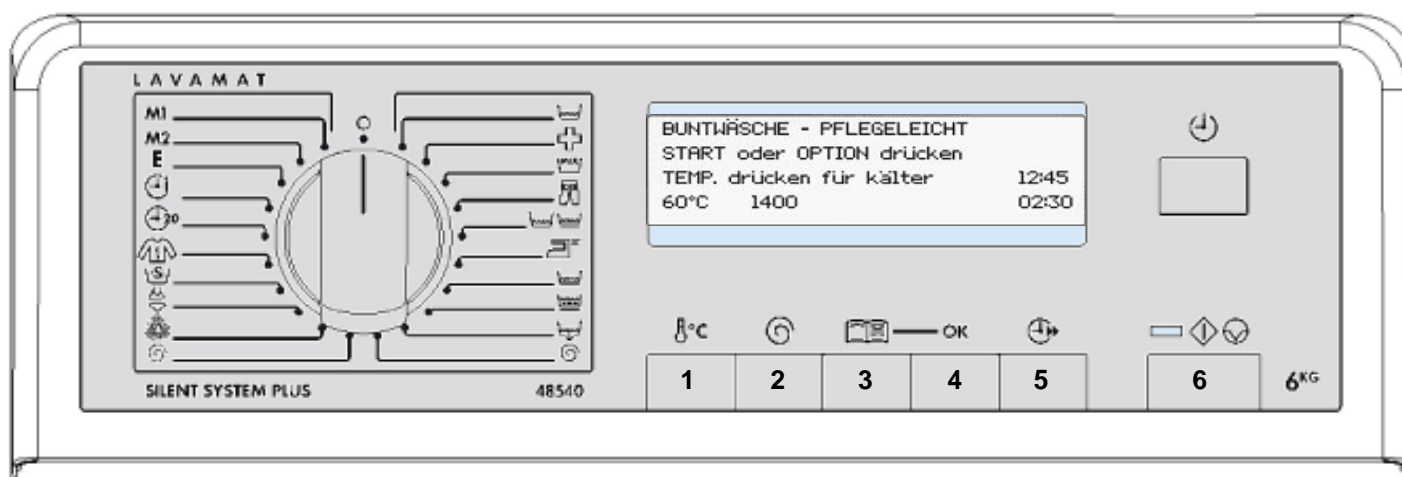

Activation and deactivation of the buzzer:

Function:

- Depending on the model, the electronic may include a buzzer.
- Switch off the appliance.
- Hold buttons 3 and 1 pressed simultaneously and turn the program selector one position to the right. The buzzer is activated.
- You can deactivate the buzzer by repeatedly pressing the key combination.

Activation and deactivation of the extra rinse cycle:

Function:

- Depending on the model of the appliance you can select an extra rinse with an extra rinse key not existing.
- This button is effective in the cycles cotton/coloured wash, synthetics and delicate fabrics.
- Two additional rinse cycles are added.
- No intermediate rinse, except after the last rinse cycle.
- Switch off the appliance.
- Hold buttons 4 and 2 pressed simultaneously and turn the program selector one position to the right. The extra rinse is activated.
- You can deactivate extra wash by repeatedly pressing the key combination.

Functions of the System

Electronic EWM3500 with asynchronous three-phase motor

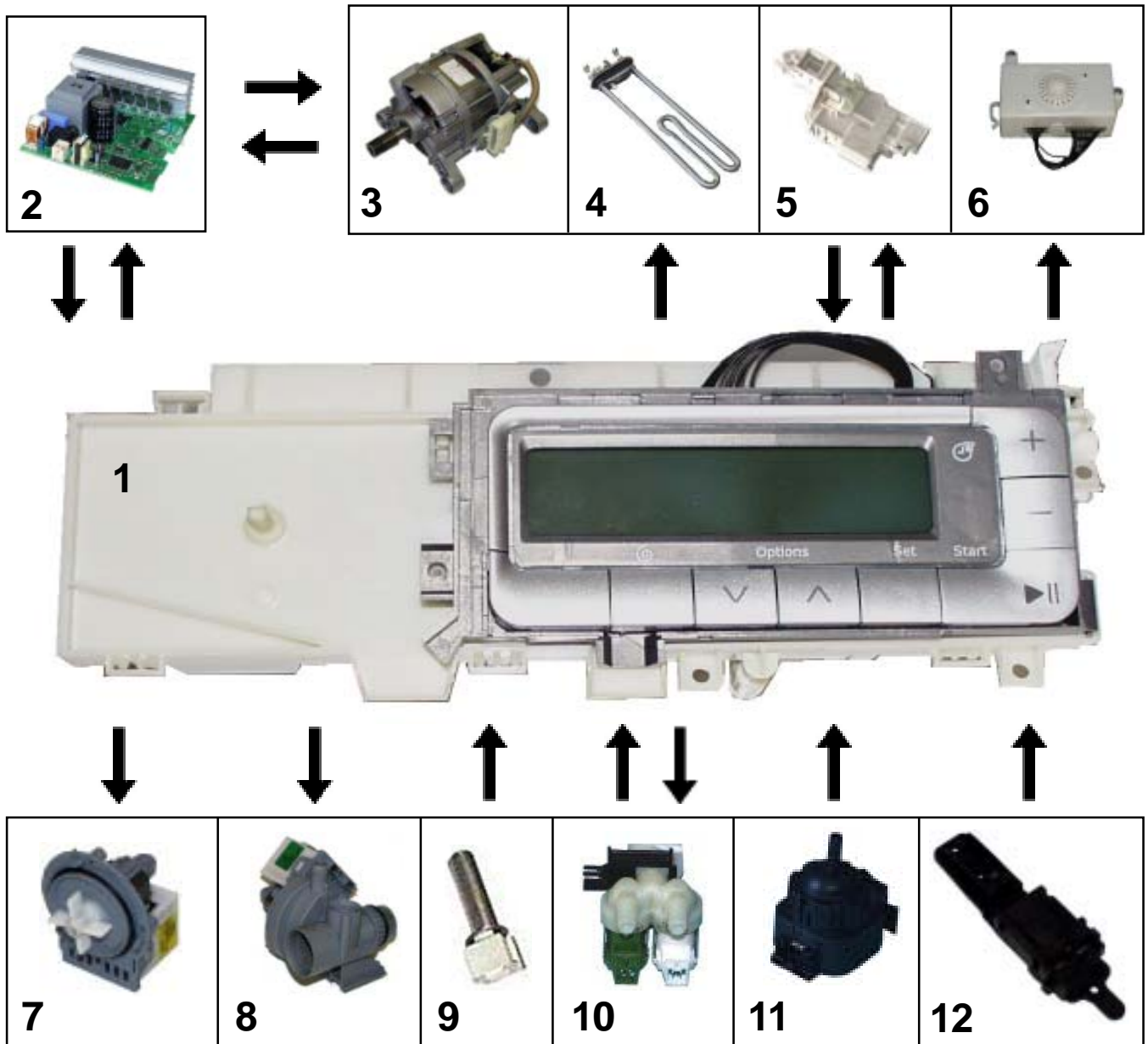

1. electronic module
2. motor control board
3. motor
4. heating element
5. door security
6. loudspeaker
7. drain pump
8. circulation pump
9. NTC-sensor
10. inlet valve with flow-meter-sensor
11. analog pressure switch
12. drum self position (DSP)

Connection cable electronic

Electronic EWM3500

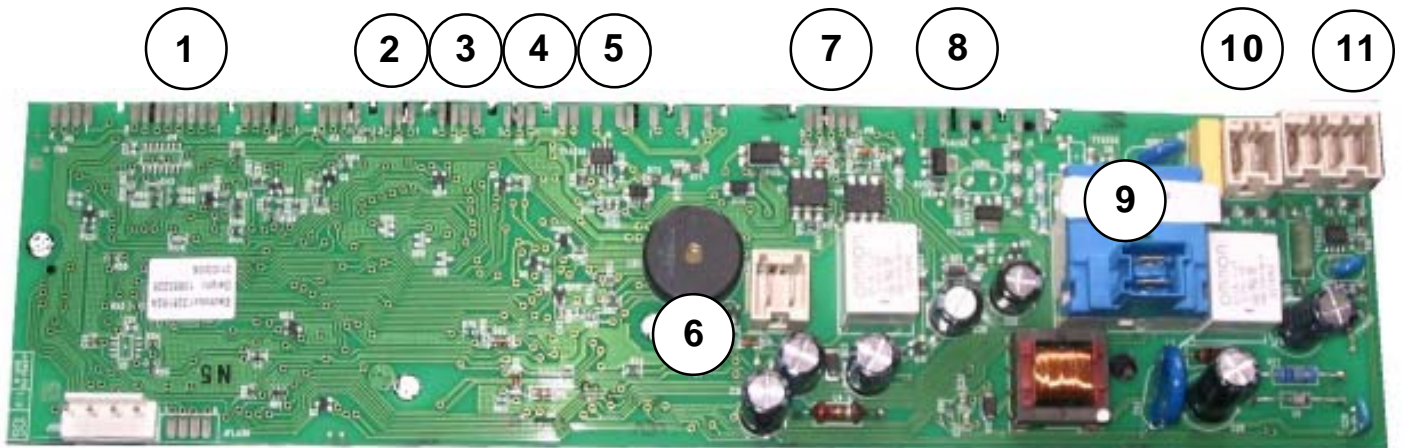

1. multifunctiondisplay LCD
2. drum self position (DSP)
3. flow-meter-sensor
4. analogic pressue switch
5. NTC-sensor, Inlet valve
6. Power supply motorcontrol board
7. motorcontrol board +5V
8. drain pump, circulation pump
9. Power supply 230V
10. heating element
11. door security

Electronic Module

The electronic module, including the μ P, controls various functions and is placed in a protective housing.

It is the communication interface between the user and the appliance.

It consists of:

- The option buttons and the multifunctiondisplay LCD.
- The programselector with 21-positions.
- The time display and the alarm identification.
- The "Start/Pause" button.



Functions:

- Taking data of the selected cycle programs through the module.
- Water level control in the tub; the level is recognized by the analog pressure switch.
- Cycle temperature control by a NTC sensor.
- Power supply of the heating element.
- Power supply of the drive motor and control of its speed by the tachymetric generator.
- Control of the motor control board.
- Control of water inlet valves.
- Control of the language unit on the modul LCD.
- Control of drain pump, circulation pump, door lock and DSP (drum self position).

In case of a power failure the module saves the just paused cycle.

- When the power supply to the appliance is restored again, the cycle starts where the program was paused.

Loudspeaker

The speaker is connected with the input/output electronic through two flat line.
The micro processor is equipped with an own firmware. They indicate two kinds of messages to support the user.



- The micro processor includes 3 different acoustic melodies.
 1. When the appliance is switched on.
 2. When the appliance starts with the wash cycle.
 3. When an error code is indicated.
- The micro processor includes and controls the language to the LCD.

On the micro processor 25 various languages have been programmed and can be selected.

Language	English	Portuguese	Finnish	Lettish	Slovakish
	Italian	Dutch	Greek	Lithuanian	Slovenish
	German	Danish	Russisch	Polish	Croatish
	French	Norwegian	Ukrainish	Czech	Romanian
	Spanish	Swedish	Estonian	Hungarian	Turkish

Door Lock

2 = N
 3 = impulse electronic
 4 = L
 5 = electronic J1-2

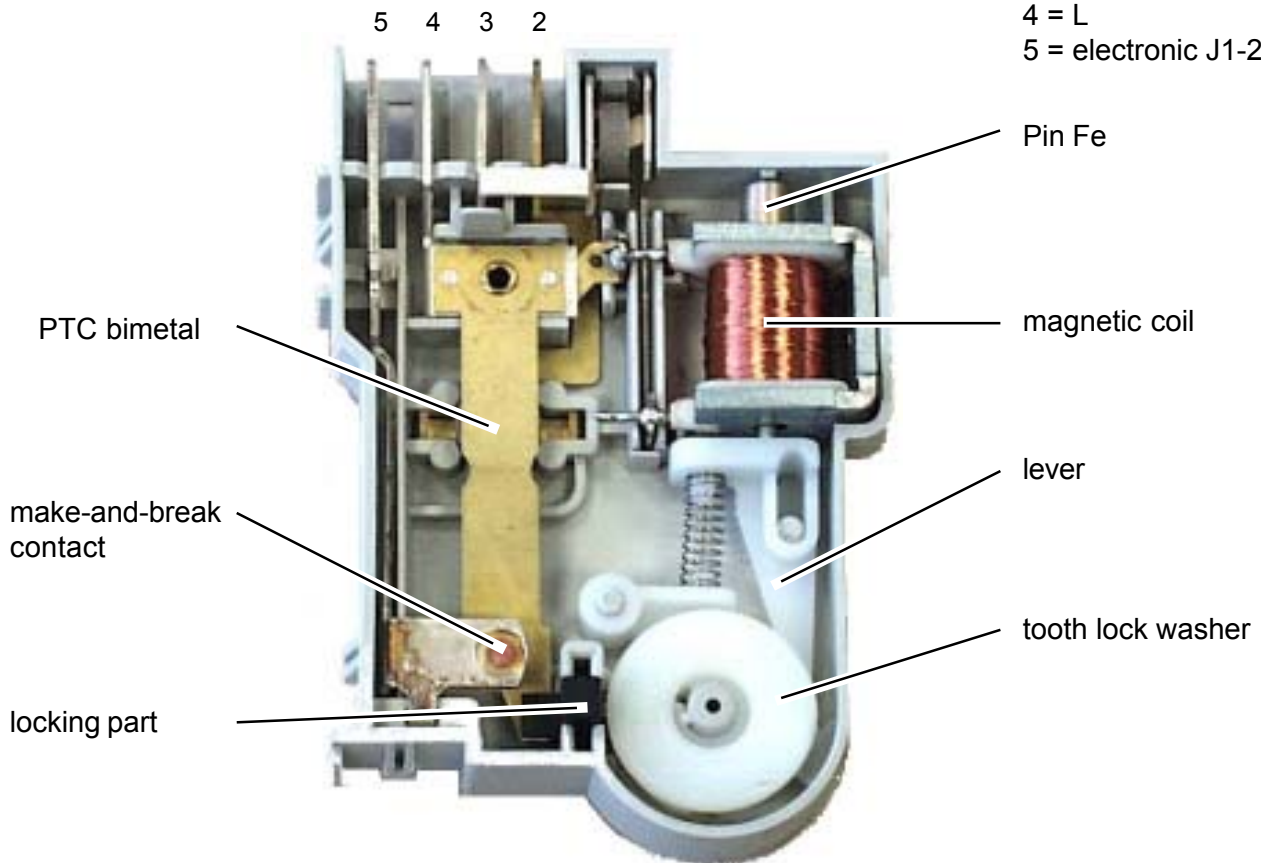

When closing the lid the door lock gets an impulse from the electronic by contact 3. The impulse feeds the magnetic coil over the PTC resistor. This moves the lever down and the tooth lock washer is forwarded by another tooth. This can be heard by a click. The locking part is unlocked, the lid is closed.

When opening the lid, e.g. with the start/pause button or at the end of the cycle, the door lock gets two impulses from the electronic. The tooth lock washer is moved twice. Only because of the second impulse the lid can be opened **immediately**.

The second impulse unlocks the locking part mechanically through the tooth lock washer.

Why two impulses?

The door lock is controlled by a triac which is on the main circuit board. If there is a triac short circuit, the electronic sends an impulse to the door lock. The customer could open the appliance, if the second impulse was not required.

If there is a **power failure** during a wash cycle, the door lock requires approx. 2 min until the lid can be opened. During this time the PTC bimetal cools down and the locking part opens.

Circuit Diagram

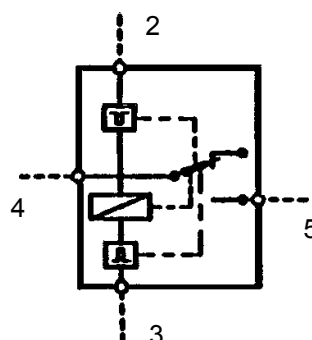

Security:

(see page **Service - Program** fault display E40)

DSP (Drum-Self-Position)

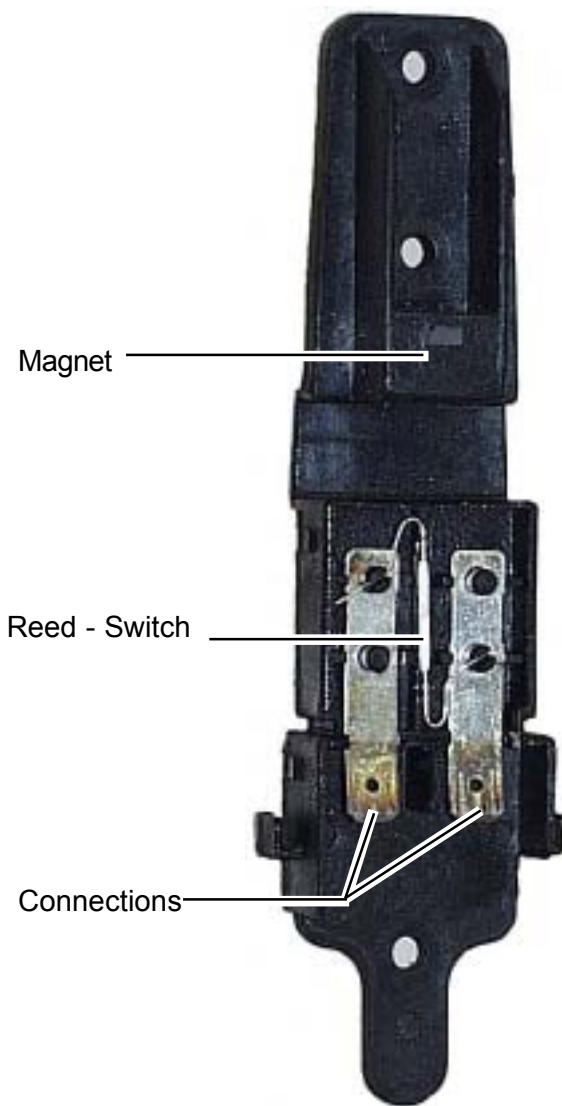

Control (check) the DSP-Function:

1. Remove the two plugs from the DSP and check the resistance of the reed relay.
 - Turn the drum to the right position ---> $> 0\Omega$
 - Turn the drum over the right position ---> 0Ω
2. The drum is still in the right position. Now measure the voltage. 5-6V DC
 - If there is no voltage ---> Cable, Main electronic board is defective

Function:

The reed relay is closed if the metallic sheet, located on the pulley, isn't between the magnet and the reed relay. If the position of the metallic sheet is between those parts the contact of the reed relay is opened.

To mount the pulley in the correct way, you have to take care about following items:

The metal sheet located on the pulley should be in the drum self positioning device, if the door of the drum is in the upper position. The DSP is supplied with 5-6 V DC by the main board.

Condition drum positioned:

Reed contact opened, 5-6V DC.

Condition drum out of position:

Reed contact closed, 0V DC.

If the washing cycle is interrupted by the start pause button the drum has to be positioned within 10 sec. During this time 2-3 attempts can be executed. If the drum isn't positioned during this time, the lid of the appliance is released and can be opened.

At the end of the cycle the positioning phase is 2 min until time out is reached.

Float switch

The float switch is made of a housing with a micro switch and a float body.

Function:

The float switch is located in the bottom tray. The bottom tray is constructed in a way that the water is gathering in the area of the float switch in case of leaky components (tub, hoses, etc.). The float body comes up and switches a micro switch. This selects the drain pump, the existing water in the tub is drained. The inlet valve is switched off.

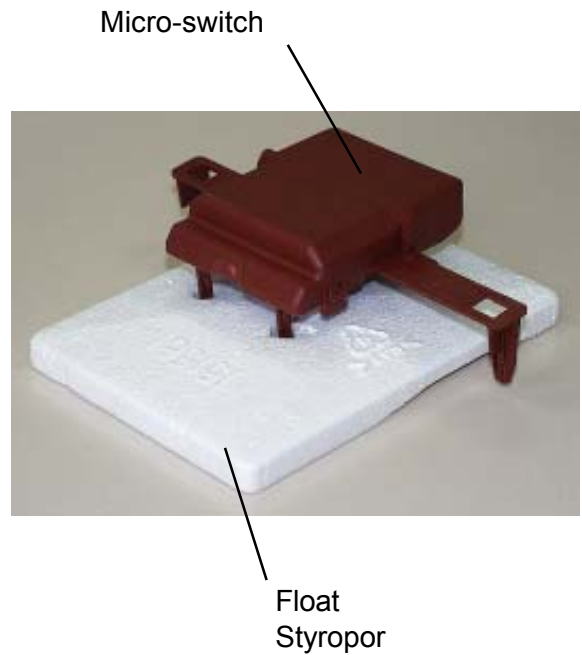

Inlet valve with flow-meter-sensor

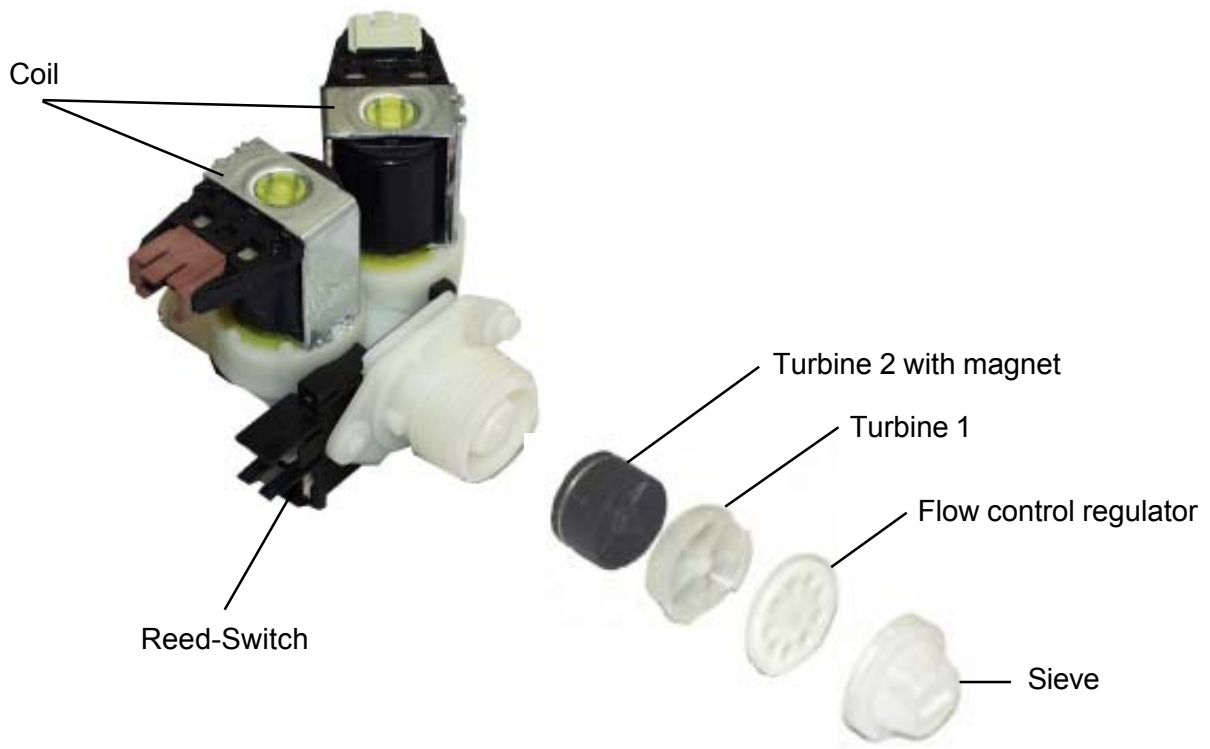

Depending on the type of appliance, the automatic washer can be equipped with a 2-fold inlet valve with or without flow-meter-sensor.

Function:

The inlet valve includes a flow meter sensor. The flow meter sensor emits electrical pulses of 5V to the main electronic. This is enabled by a magnet which opens and shuts a reed contact. The magnet is located on a movable turbine 2. Because of the water pressure the turbine rotates and thus gives impulses to the main electronic. The water pressure of > 1 bar is limited by the volume regulator to 5.5 l/min +15%/-15%.

(see Page **Service - Program** fault display EC1)

Water Inlet Valve for 3-chamber detergent box

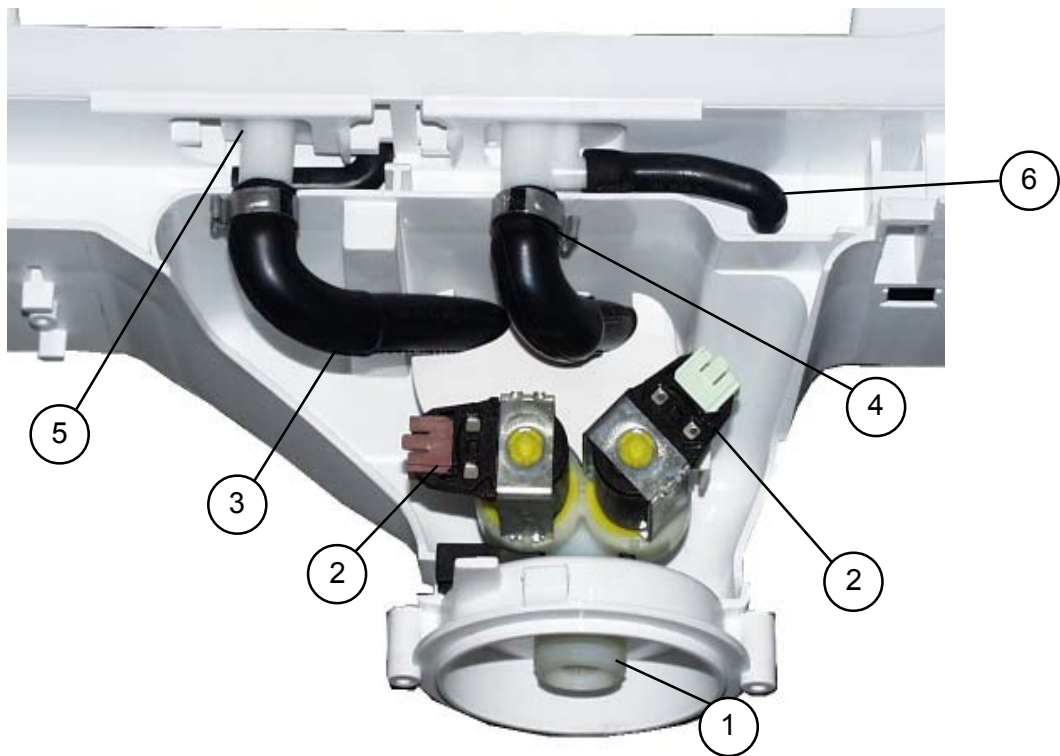

- 1 - connection water inlet hose
- 2 - inlet valve, 2-fold
- 3 - hose for pre-wash
- 4 - hose for main wash
- 5 - water distributor
- 6 - hose for fluff filtre

***) Attention!**
The simultaneous filling through hoses 3 and 4 provides the fill-in through the softener chamber.

Water Distributor

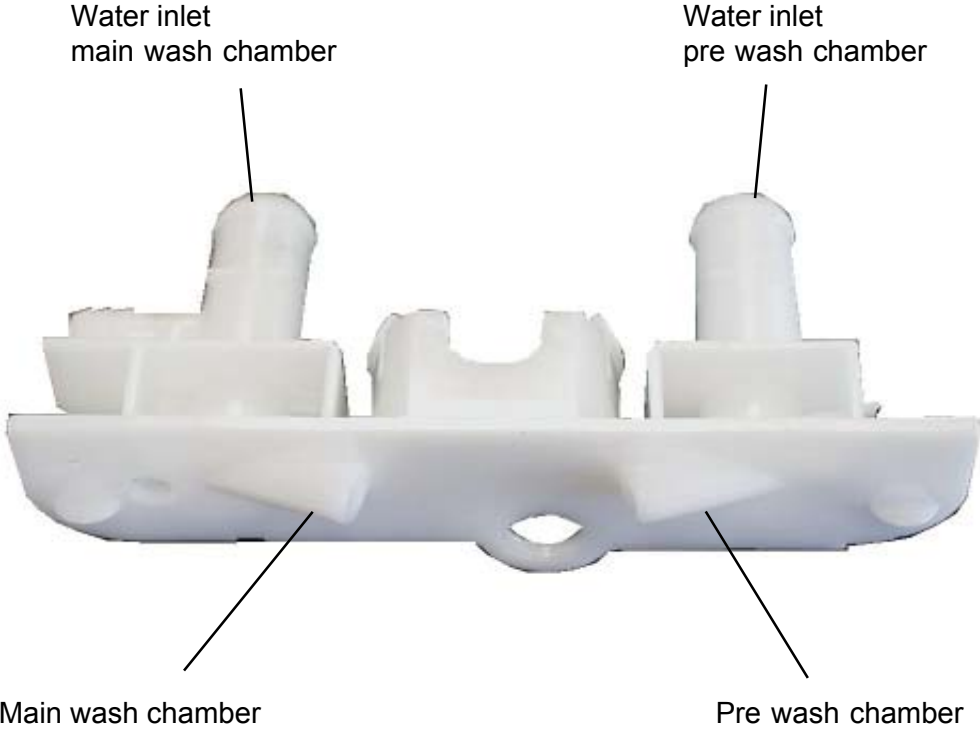

Analogic pressure switch

The analogic pressure switch controls the water level in the tub, it is directly connected to the electronic modul.

If the pressure switch does not work correctly, the programm in progress is cancelled:

1. Pressure switch hose connection
 2. Diaphragm
 3. Coil (self)
 4. Electronic circuit (oscillator)
 5. Magnet
 6. Spring
 7. Adjusting screw
 8. Connector
- Kontakt 1 = Out
 Kontakt 2 = GND
 Kontakt 3 = 5V DC

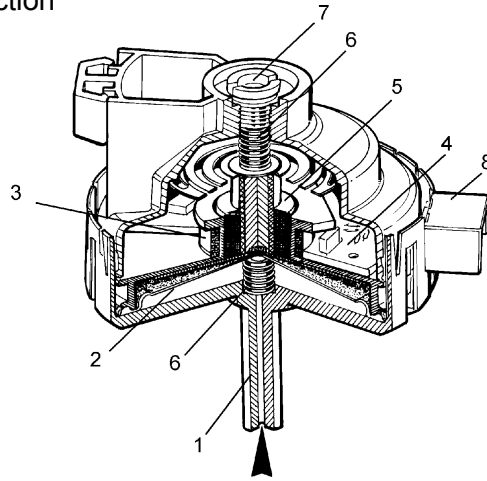

When the tub is full, the pressure inside the hydraulic circuit acts on the diaphragm which moves the magnet inside the coil.

This moving modifies the inductance of self and consequently the frequency delivered by the scillatory circuit. the μP , after frequency reading, recognizes the water level inside the tub. (see Page **Service - Program** fault display E30)

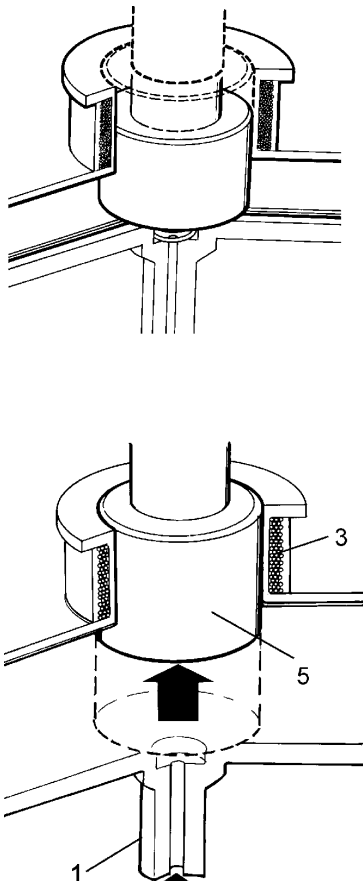

Frequency delivered follow the pressure (± 50 Hz)

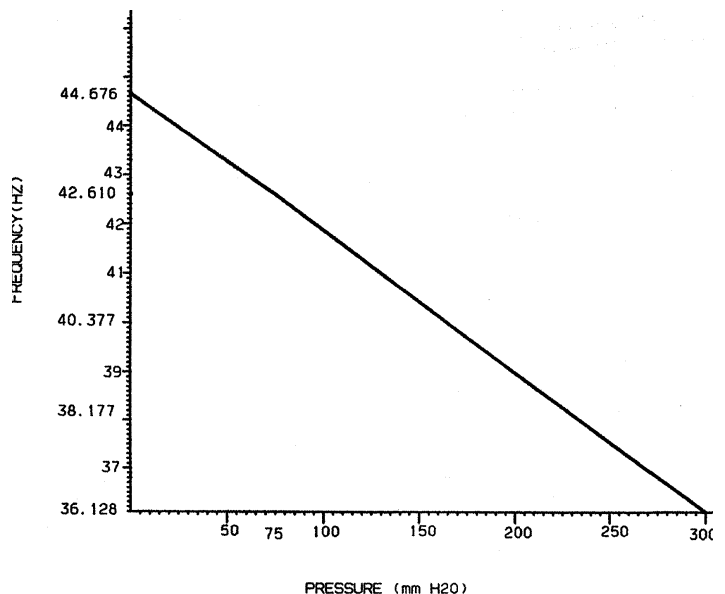

Heating element



Connection: 230V; 50Hz;
Power: 1950W
Fuse: 10A

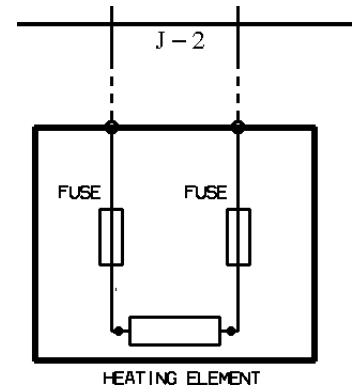

The heating element is supplied with power directly from the control electronics by means of a relay. For security reasons, 2 switching contacts of the pressure switch are connected in series. The switching positions are monitored by control electronics via 2 control lines.

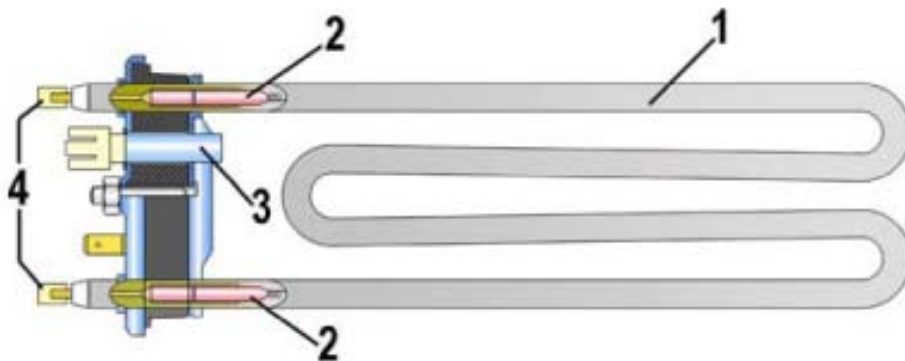

1. heating element
2. temperature fuse
3. NTC-sensor
4. connections

Check of insulation resistance with the heating

Wash a cycle for approx. 10 minutes. Switch off the appliance, unplug the plug and remove the side panel.

Draw off the connecting lines from the heater.

Measure the resistance between heating (depending on connection) and mass.

Resistance > 200 kOhm → heater OK.

Resistance < 168 kOhm → error E68

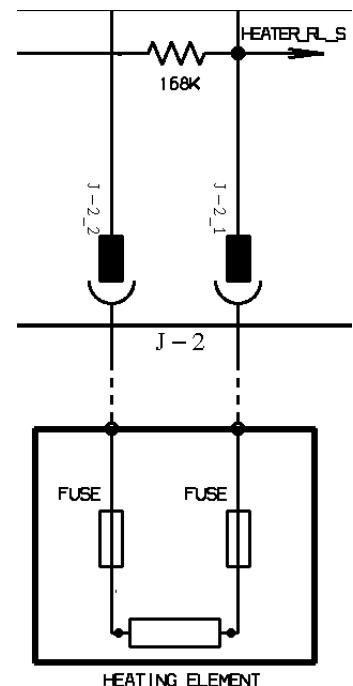

Heating Circuit

The cycle temperature is fixed by the μP depending on the selected program.

The temperature control is guaranteed by the μP through the NTC temperature sensor. The temperature sensor reduces its resistance according to the temperature increase.

The reduction in the ohmic value of the temperature sensor is detected by the μP ; as soon as the selected temperature is reached the power supply to the heating element will be paused.

The NTC sensor is integrated in the heating element.

NTC-Sensor

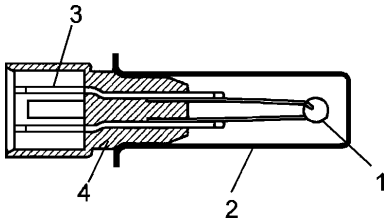

1. NTC resistance
2. Metallic casing
3. Connections
4. Plastic casing

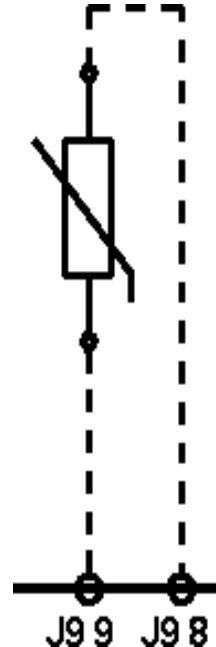

To check the NTC sensor function you can measure the ohmic resistance between the contacts J9/8 and J9/9.

Variations of NTC resistance

Temperature ($^{\circ}\text{C}$)	Resistance (Ohm)
25	4815 \pm 207
40	2563 \pm 102,5
60	1196 \pm 26,31
80	602 \pm 19,89

Security

- The μP will be break off if an anomaly on the termistance circuit is detected : cut or short-circuit. (see Page **Service-Program** fault display E70)
- The heating phase is not executed.

Drain pump / Circulation pump

The drain pump is directly controlled via triac from the control electronics.

Motor / Motor control board

Electronic EWM3500

These appliances include a 2-pin asynchronous three-phase motor. This motor is directly driven by a special inverter motor electronic system. This changes the frequencies of the rotary current in accordance with the required rotational speed. The motor electronic system is connected with the control electronic system via a control line.



Connection:

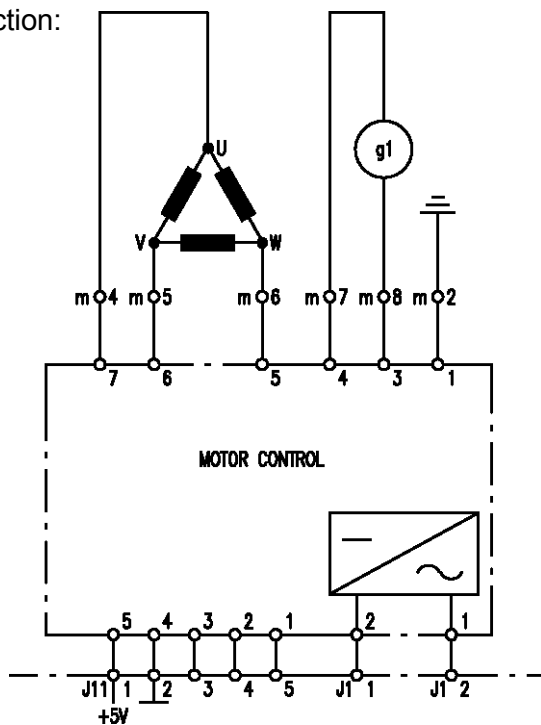

The ohmic resistance of the tachometer generator amounts to approx. 119 Ohms. The measurable resistance of the motor coils can be measured between the connection contacts of motors m4-m5 / m4-m6 / m5-m6 and amount to approx. 5.5 Ohms in each case. The phase shift between the phases is 120° and peak amplitude is 310V.

Safety

- If the transistor for the motor is in short-circuit, or if the tachometer generator is interrupted, 4 trials are executed in intervals of 5 minutes each. After a break of 20 minutes, the fifth and last trial is started. If the motor does not run this time, the programme is aborted. (see Page **Service-Program** fault display E50)

Drum movements

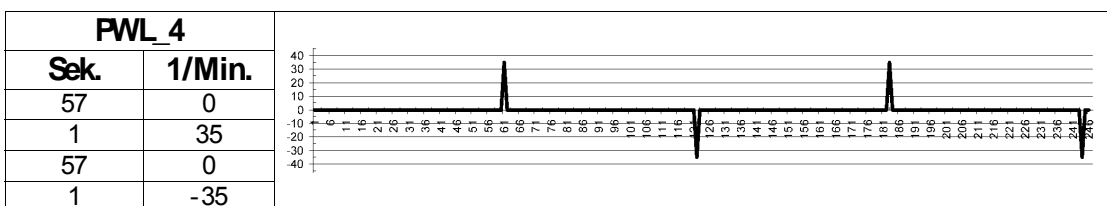
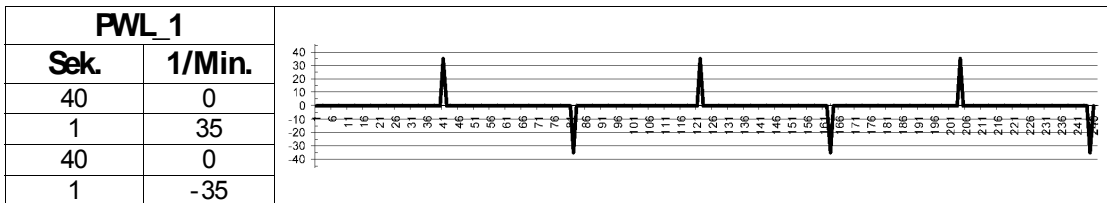
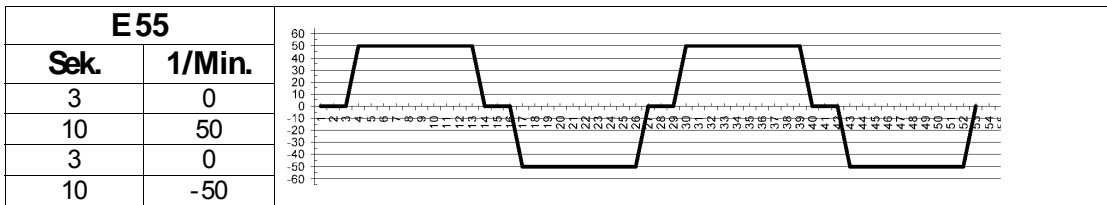
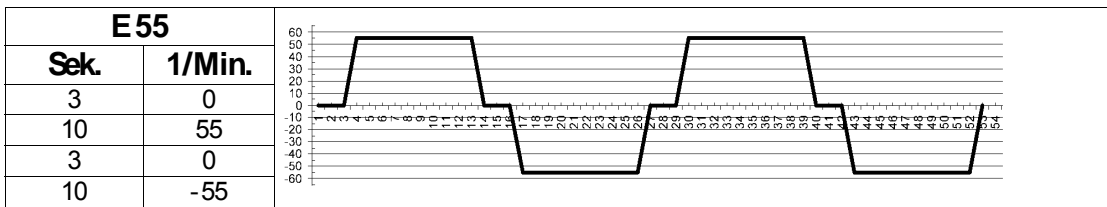
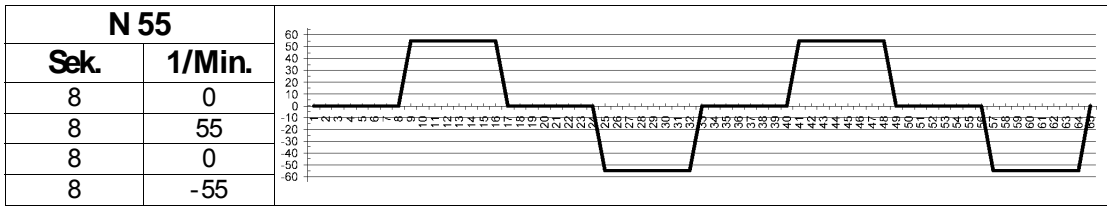
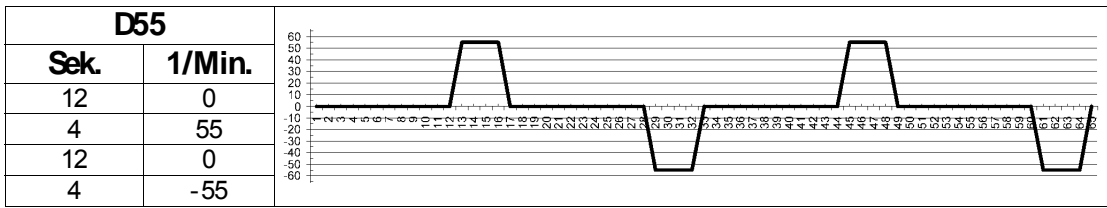

Spin profiles

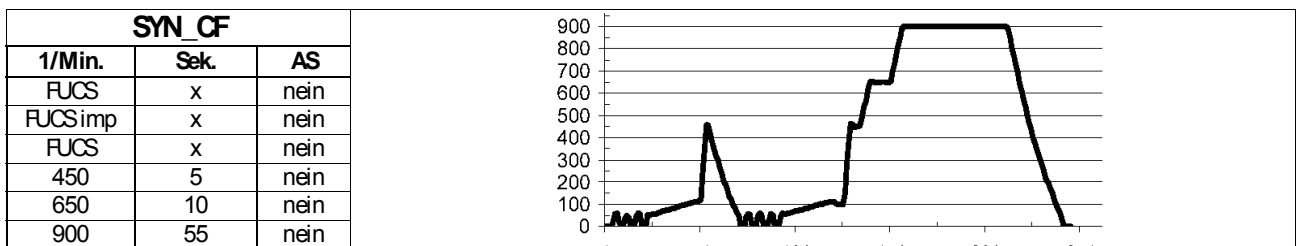
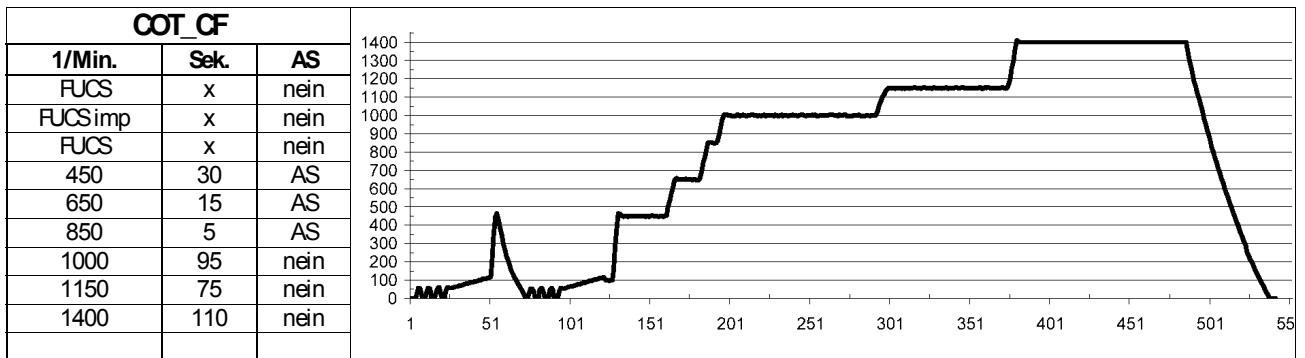
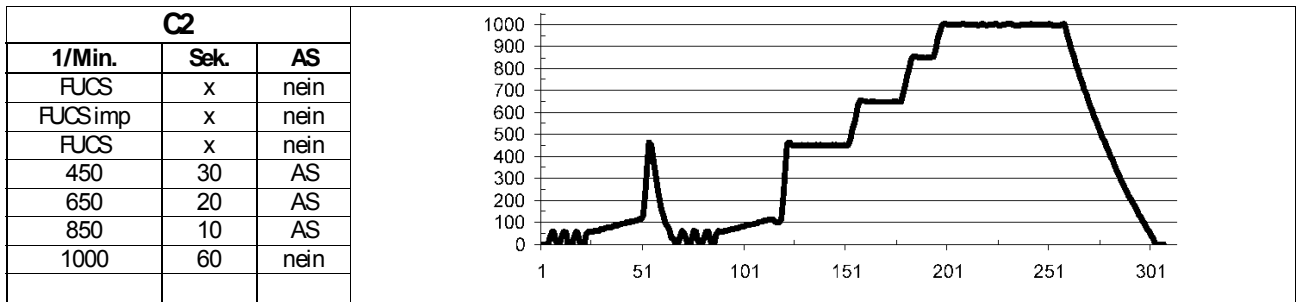
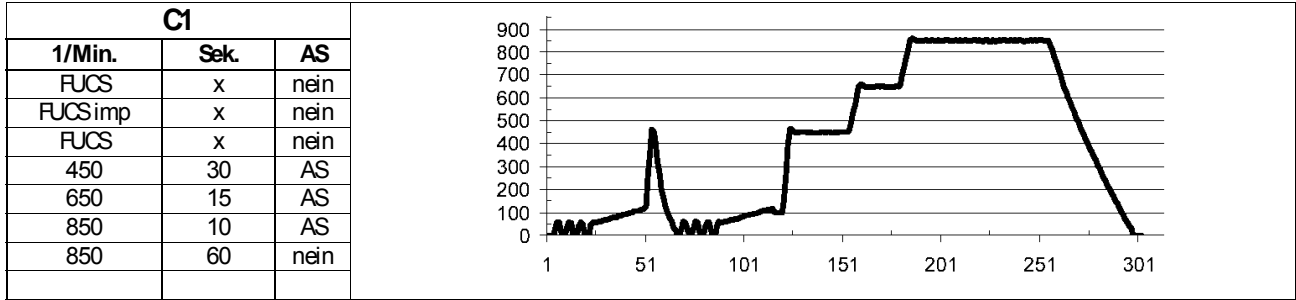
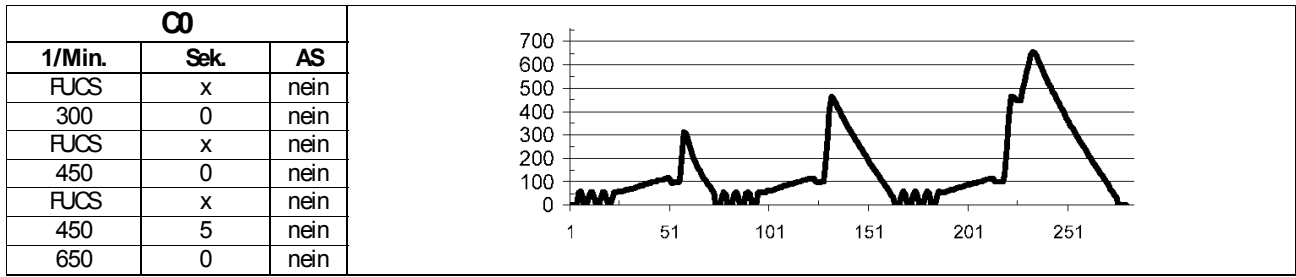

Spin profiles

CF (Feinwäsche)		
1/Min.	Sek.	AS
FUCS	x	nein
FUCSimp	x	nein
FUCS	x	nein
450	35	AS
700	5	AS
900	20	AS

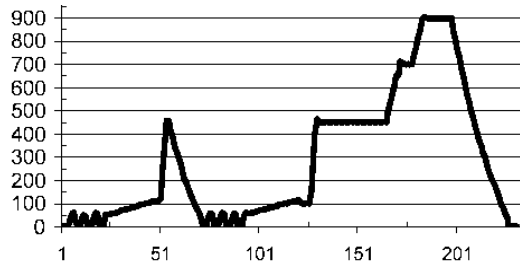

CF (Wolle)		
1/Min.	Sek.	AS
FUCS	x	nein
FUCSimp	x	nein
FUCS	x	nein
450	5	AS
650	1	AS
850	1	AS
1000	20	nein

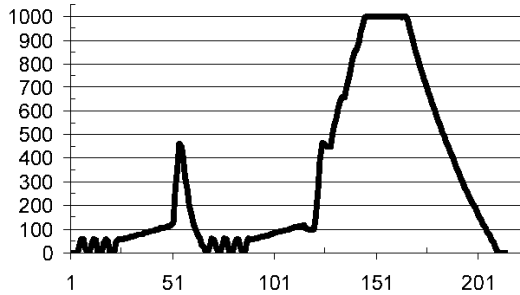

Separater Schleudergang		
1/Min.	Sek.	AS
FUCS	x	nein
FUCSimp	x	nein
FUCS	x	nein
450	10	AS
650	10	AS
850	10	AS
1000	10	nein
1150	10	nein
1400	20	nein

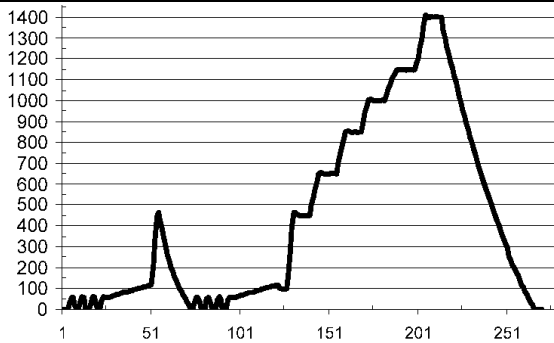

EASY_IRON_IMP		
1/Min.	Sek.	AS
FUCS	x	nein
450	0	nein
FUCS	x	nein
650	0	AS
FUCS	x	nein
800	0	AS
FUCS	x	nein
900	0	AS

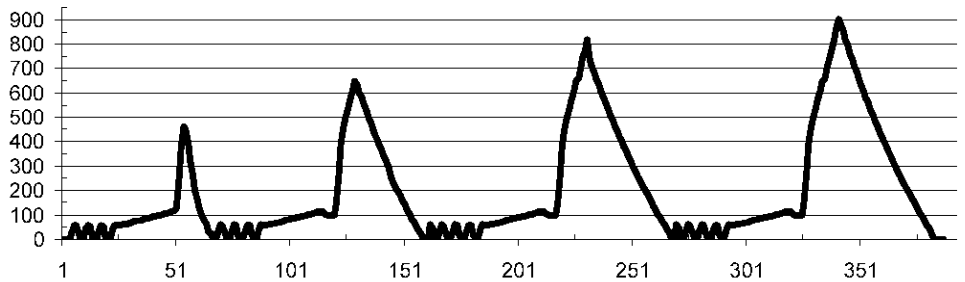

CSR		
1/Min.	Sek.	AS
FUCS	x	nein
FUCSimp	x	nein
FUCS	x	nein
450	120	AS

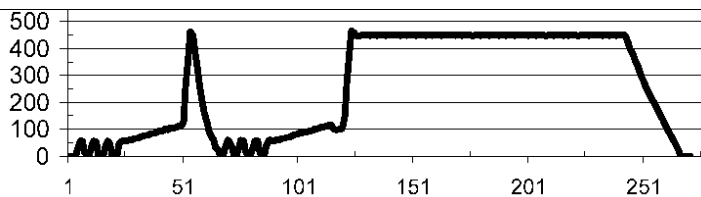

AS indicates that the anti-foam function is active.

Function of the FUCS

“FUCS” is an English expression and means “Fast Unbalanced Control System”

Function:

The unbalance control includes 4 phases. These phases are of different duration and have different limits of unbalance. The magnitude of the unbalance is calculated every 300 ms, hereby the magnitude is compared to the fixed unbalance limits, and then it is decided whether the speed will be increased or reduced by 2 1/min. FUCS starts at 55 1/min and ends ideally when reaching 115 1/min.

- Phase 0: When the unbalance threshold (850gr.) of the first phase is reached, the appliance performs a spin cycle with 100 1/min for 5 sec followed by a spin cycle pulse of 470 1/min.
- Phase 1: The first phase (350gr.) takes max. 120 sec to obtain the required speed of 115 1/min. If the speed is not reached after this 120 sec, the spinning cycle will be stopped. The laundry is dispersed and it is changed to phase 2.
- Phase 2: Phase 2 (650gr.) takes max. 60 sec. Here it is tried to obtain the speed of 115 1/min with various unbalance limits. If the speed is not reached after 60 sec, the spinning cycle will be stopped again. The laundry is dispersed and it is changed to phase 3.
- Phase 3: In phase 3 (1200gr.), the required speed is reduced to 85 1/min. Within 90 sec, speed should be reached, the machine then runs a spin-dry cycle at 100 1/min for 5 sec. and a subsequent spin-dry pulse at 470 1/min, then again starting by phase 1. If the speed is reached, a reduced spin-dry cycle at 650 1/min is carried out. If the speed is not reached, spin-dry is skipped.

Perfect balance

- Reversing
- FUCS phase 0 with spin-dry pulse
- Reversing
- FUCS phase 1
- regular spin-dry

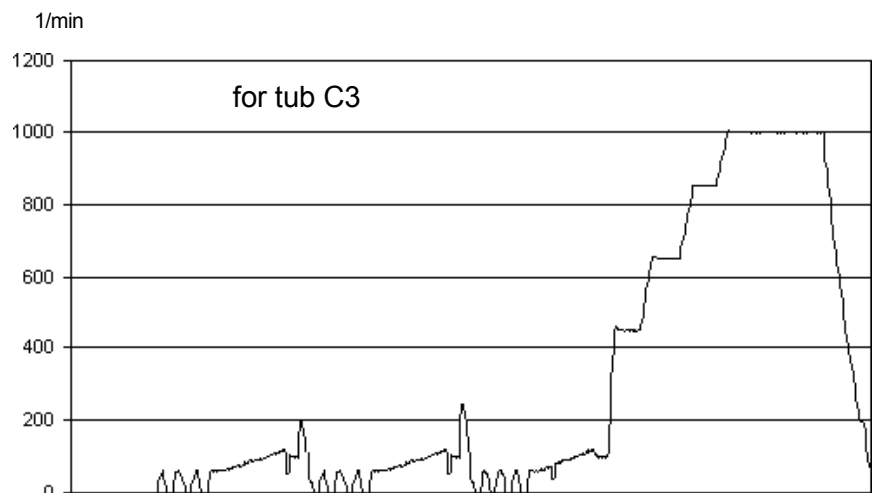
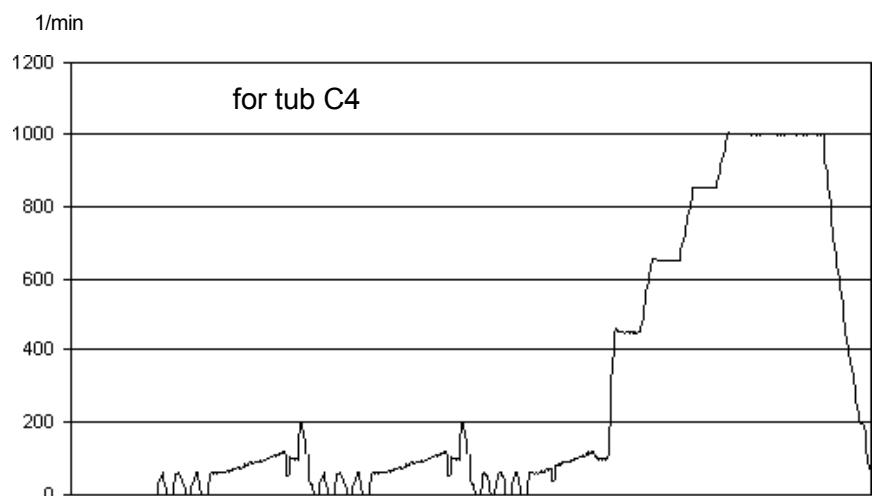

Balancing after two attempts

- Low speed
- FUCS phase 0
- FUCS phase 1
- FUCS phase 2

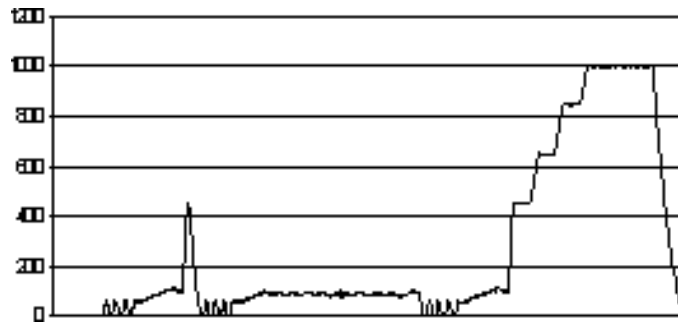

Balancing after the third phase (normal spin-speed)

- FUCS phase 0 with spin pulse
- FUCS phase 1
- FUCS phase 2
- FUCS phase 3 with spin pulse
- FUCS phase 1
- FUCS phase 2
- FUCS phase 3
- Normal spin

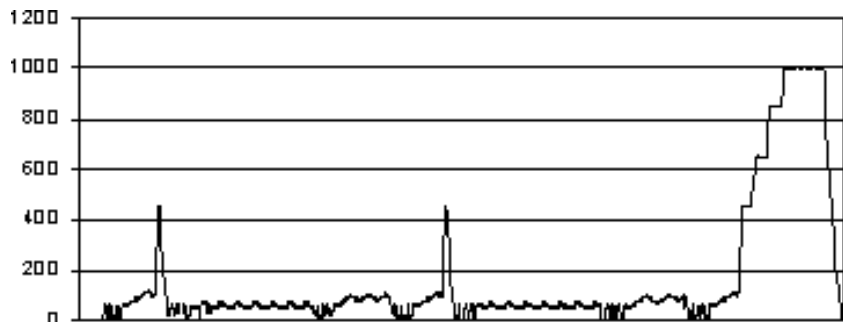

Balancing after the third phase (reduced spin-speed)

- FUCS phase 0
- FUCS phase 1
- FUCS phase 2
- FUCS phase 3 with spin pulse
- FUCS phase 1
- FUCS phase 2
- FUCS phase 3
- reduced-speed spin

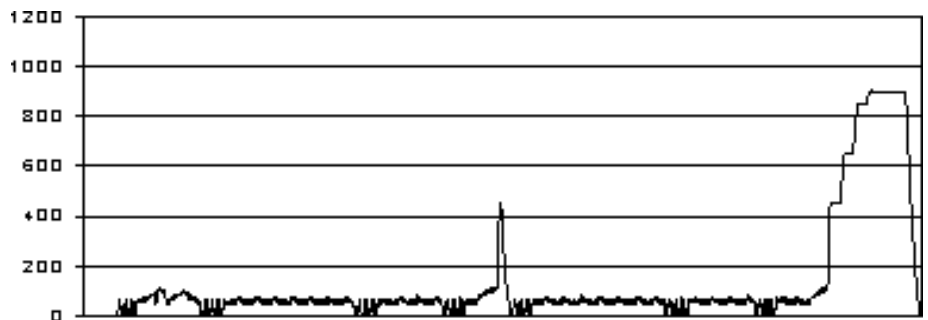

Unalancing after the third phase

- FUCS phase 0
- FUCS phase 1
- FUCS phase 2
- FUCS phase 3
- FUCS phase 1
- FUCS phase 2
- FUCS phase 3
- no spin

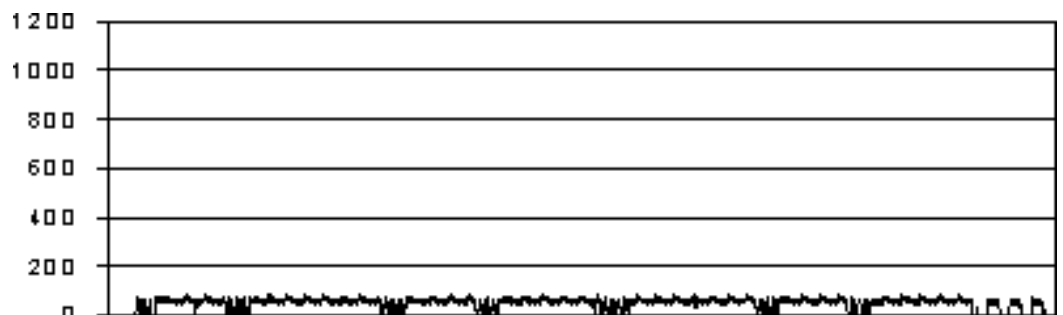

Foam Detection

Anti-foam control is excited via analog pressure switch.

Spin-dry phase without foam:

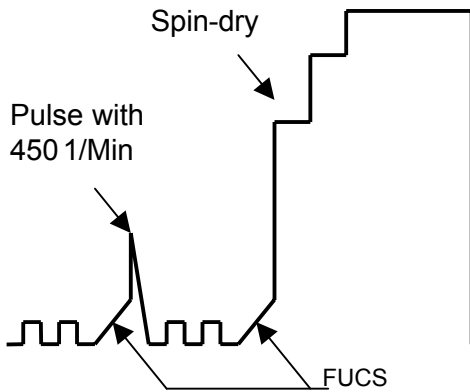

Spin-dry phase with little foam:

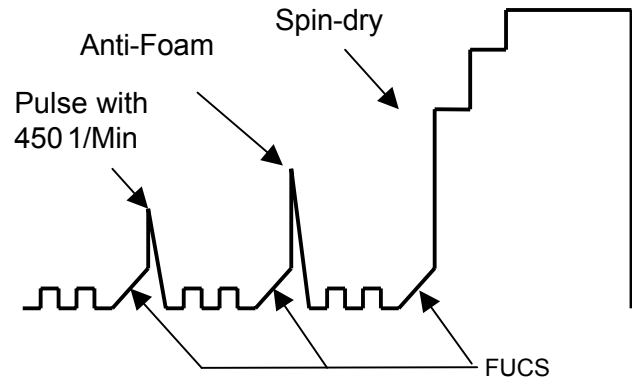

Spin-dry with little foam:

When the analogous pressure switch detects foam (45 mm "full"), the spinning cycle is stopped and the drain pump keeps on running until the foam level will be fallen below (15 mm "empty") and the spinning cycle is continued.

Spin-dry with excess foam:

When the analogous pressure switch detects a foam 5 times (45 mm "full"), the spinning will be skipped. Draining is carried out for 1 minute with the motor at stop. If too much foam is detected during any wash cycle, an additional rinse cycle is added.

Service Program

Fault indication by multifunctiondisplay LCD

- Switch off the appliance.
- Hold buttons 6 and 5 pressed simultaneously and turn the program selector one position to the right.
- Hold the two selected buttons pressed until possibly a buzzer will sound and/or the LCD will give a light.
- By the program selector it is possible to interrogate the desired checking function according to the table.

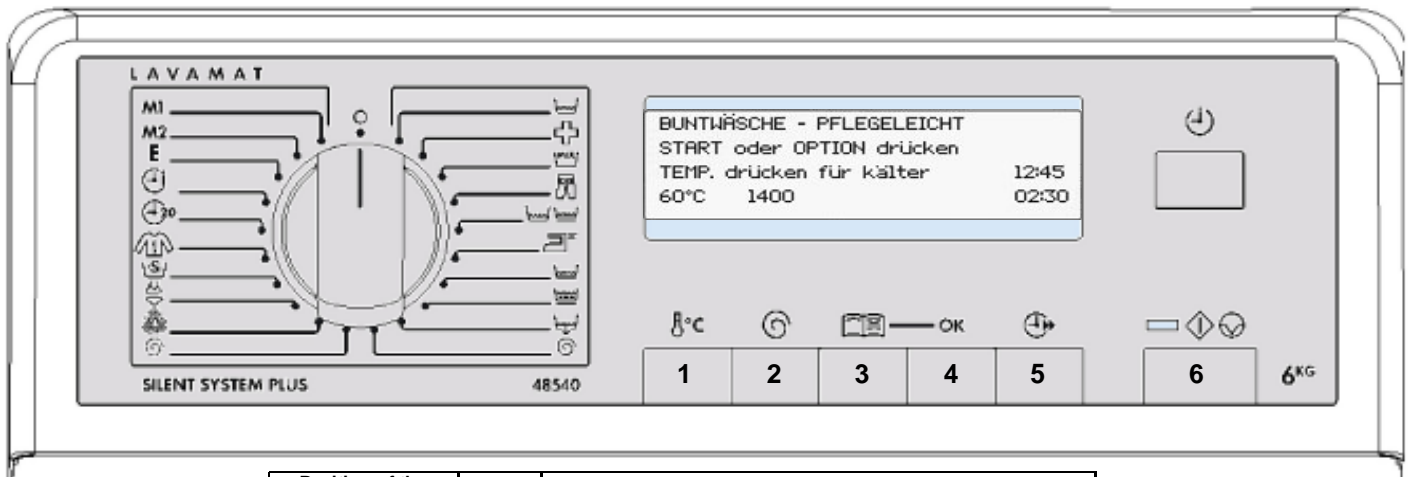

Position of the rotary switch	Button	Test function
Off		Off
21 Positions		
01	Button 6 and Button 5	1) Start of the customer service testprogram 2) LCD - Test LEDs are step by step illuminated. If you press a button the according LED is on.
02		Water channel mainwash Water intake up to safety level fS Time max. 5 min Valve mainwash Display indicates current water level in mm
03		Water channel prewash Water intake up to safety level fS Time max. 5 min Valve prewash Display indicates current water level in mm
04		Water channel softener Water intake up to safety level fS Time max. 5 min Valve mainwash and prewash Display indicates current water level in mm
05		Water channel spots Water intake up to safety level fS Time max. 5 min Valve spots or hotwater Display indicates current water level in mm
06		Heating and circulation pump Heating up to 90°C Time max. 10 min Water intake over mainwash chamber Display indicates current temperature in °C
07		Tub leakage test Water intake over mainwash chamber up to 1. Niv. Motor rotation 250 1/min Display indicates current speed in 1/min
08		Draining and spinning Draining Spinning up to maximum spin speed, if level < fSch Display indicates current speed in 1/min
09		DSP The drum is positioned if level < fSch
10		Displaying the error code (programme display)

Service Program

Fault indication by multifunctiondisplay LCD

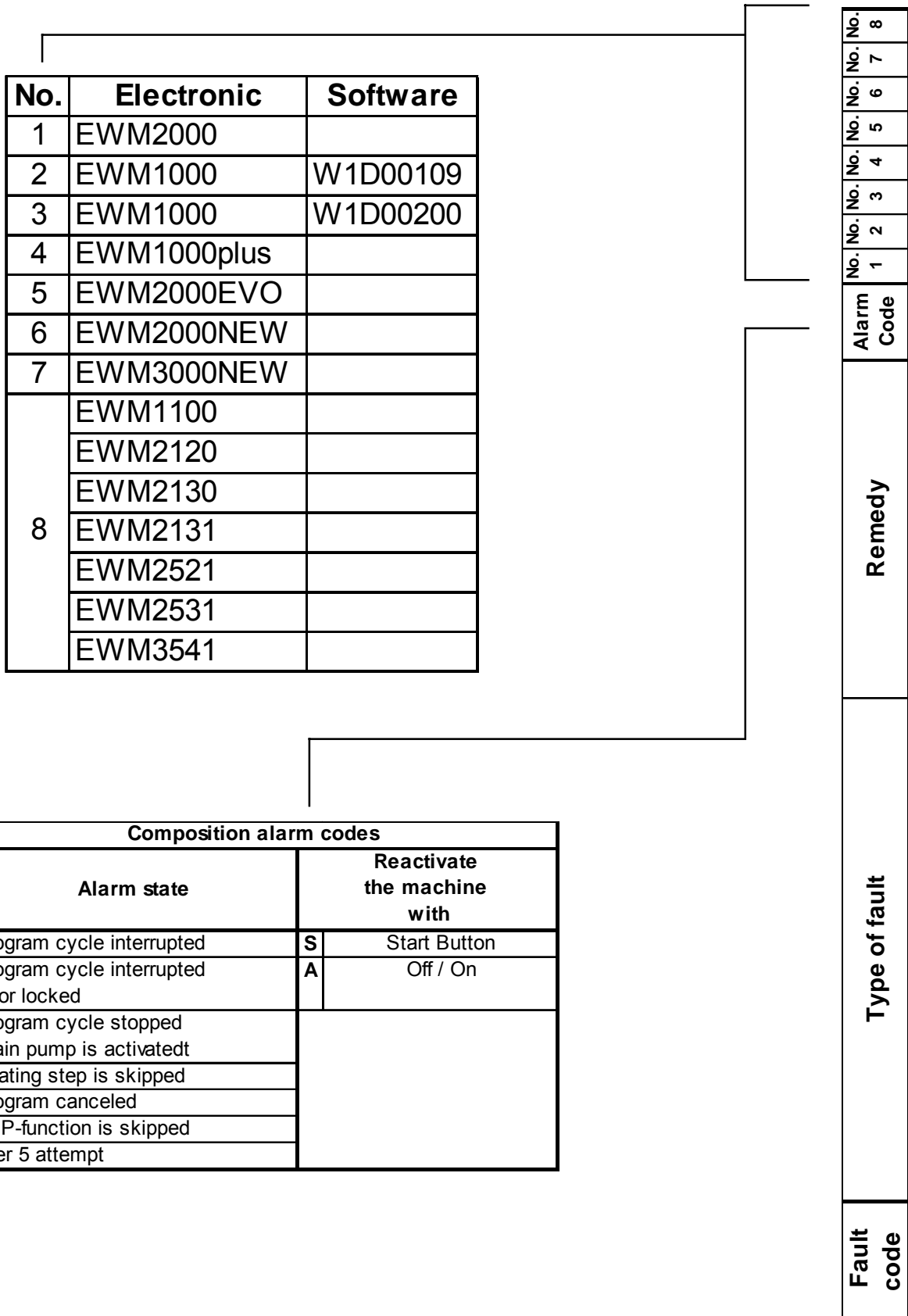

Service Program

Fault indication by multifunctionsdisplay LCD

Fault code	Type of fault	Remedy	Alarm Code	No.	No.	No.	No.	No.	No.	No.	No.	No.
				1	2	3	4	5	6	7	8	
E10	E11 No water filling Water tap closed Valve does not open / interruption Valve flow rate to low Air trap system leaking Cable defect Electronic defect	Open tap Change the valve Clean filter Replace air trap Cable pressure sw itch and electronic Replace electronic	1 S	X	X	X	X	X	X	X	X	X
E20	E13 Not enough water Wrong drain pipe position Valve flow rate to low Inlet valve defect Pressure sw itch defect Hose for pressure sw itch leakage or blocked	Check the drain pipe position Clean filter Replace inlet valve Replace pressure sw itch Check the hose for the pressure sw itch	1 S	X	X	X	X	X	X	X	X	X
E21	E21 No draining Pump blocked / not working Pump interrupted Reduced pump output rate Pressure sw itch defect Pressure sensor defect Electronic defect	Remove foreign object Replace drainpump Check draining system Replace pressure sw itch Replace pressure sensor Replace electronic	0 S	X	X	X	X	X	X	X	X	X
E23	E23 Incongruence between drainpump and electronic	Replace drainpump, Cable drainpump	2 A		X	X	X	X	X	X	X	X
E24	E24 Drain pump triac sensing failure 1 Input voltage allways 0V or 5V	Replace electronic	2 A		X	X	X	X	X	X	X	X
E30	E31 Pressure sensor defect Frequency of the pressure sensor out of limit Cable interrupted	Replace pressure sensor Replace cable	1 A	X								
E32	E32 Calibration problems pressure sensor After initial calibration the w aterlevel not in between 0 - 66mm and antiboil level off	Open tap Replace inlet valve Clean filter Replace air trap, Replace pressure sensor	0 S	X								
E33	E33 Incongruence between pressure sensor and antiboil level 1 Fault has to be for a time longer than 60 sec. Incongruence between pressure sw itch Niv. 1 and antiboil level 1	Replace pressure sensor Replace cable Replace air trap	1 A	X								
E33	E33 Incongruence between pressure sw itch Niv. 1 and antiboil level 1 Fault has to be for a time longer than 3 sec.	Replace pressure sw itch, Replace electronic Replace heating element Cable pressure sw itch and electronic	1 A	X	X	X	X	X	X	X	X	X

Service Program

Fault indication by multifunktionsdisplay LCD

Fault code	Type of fault	Remedy	Alarm Code	No.	No.	No.	No.	No.	No.	No.	No.	No.	No.
				1	2	3	4	5	6	7	8		
E34	Incongruence between pressure sensor and antiboil level 2 Fault has to be for a time longer than 60 sec.	Replace pressure sensor Replace cable Replace air trap	1 A	X					X	X			
E35	Safety level (Pressure sensor) Level has to be 300mm for a time of more than 15 sec Drain pump will be activated until level is below 120 mm	Replace pressure sensor Replace cable Replace air trap	1 A	X					X	X			
E35	Safety pressure switch on for a time longer than 15 sec.	Replace inlet valve, Replace electronic Air trap system leaking Replace pressure switch Cable pressure switch and electronic	2 A		X				X				X
E36	Antiboil 1 sensing failure 1 Input voltage allways 0V	Replace electronic	1 A	X	X				X	X			
E37	Antiboil 2 sensing failure 1 Input voltage allways 0V or 5V	Replace electronic	1 A	X					X	X			
E37	Pressure switch Niv.1 sensing failure Inputvolt. allways 0V or 5V	Replace electronic	1 A		X				X	X			
E38	Airtrap blocked No pressure differences detected	Change airtrap Clean airtrap	1 A	X					X	X			
E39	sensing failure Inputvolt. allways 0V	Replace electronic	1 A		X				X	X			
E3A	Heating element relay defect	Replace electronic	1 A						X	X			X
E40	Lid open	Replace doorlock	0 S	X	X				X	X			X
E41	Door lock defect Cable defect Electronic defect	Replace cable Replace electronic	0 S						X	X			
E42	Door lock defect Door is unlocked during the cycle Tout 15 sec Door is not unlocking at the end of cycle Tout 4 min	Replace doorlock Replace cable Replace electronic	0 S	X	X				X	X			X
E43	Door lock triac defect	Replace doorlock, Replace cable Replace electronic	0 A	X	X				X	X			X
E44	Door lock sensing failure Inputvoltage allways 0V or 5V	Replace electronic	1 A	X	X				X	X			X
E45	Door lock triac sensing failure Inputvoltage allways 0V or 5V	Replace electronic	1 A	X	X				X	X			X
E50	Motortriac short circuit Motor cable short circuit	Replace cable Replace electronic	1,6 A	X	X				X	X			X
E52	No signal from tachogenerator Motor blocked Motor cable defective	Replace tachogenerator Replace motor Replace cable Replace electronic	1,6 A	X	X				X	X			X
E53	Motor triac sensing failure Input voltage allways 0V or 5V	Replace electronic	1 A	X	X				X	X			X

Service Program

Fault indication by multifunctionsdisplay LCD

Fault code	Type of fault	Remedy	Alarm Code	No.	No.	No.	No.	No.	No.	No.	No.	No.																																							
				1	2	3	4	5	6	7	8																																								
E54	Motor relay defect	Replace electronic	1,6 A	X	X	X	X	X	X	X	X	X																																							
				Motor circuit interrupted	Replace motor, Replace cable	1 A	X																																												
							No signal from tachogenerator, No signal after 15 min	Replace tachogenerator	1 A	X																																									
										Inverter current goes above threshold (>15A)	Replace motor, replace cable Replace motor control board	1,6 A							X		X																														
													Motor phase current goes above threshold (>4.5A)	Replace motor, replace cable Replace motor control board	1,6 A							X		X																											
																No tach signal for 3 seconds after new speed target different from zero	Replace motor, replace tachogenerator Replace motor control board, replace cable	1,6 A							X		X																								
																			Heat Sink temperature goes above threshold (88°C)	Replace motor control board	1,6 A							X		X																					
																						DC bus voltage goes below threshold (<175V)	Replace motor control board, replace cable	1,6 A							X		X																		
																									DC bus voltage goes above threshold (>430V)	Replace motor control board	1,6 A							X		X															
																												FCV cannot receive and/or transmit a message for more than 2 seconds	Replace cable	1,6 A							X		X												
																															There are communication problems in between FCV control board and mainboard	Replace electronic	1 A							X		X									
																																		FCV control board is continuously asking for configuration parameters due to repetitive reset	Replace motor control board, replace cable Replace electronic	1 A							X		X						
																																					Insufficient heating	Replace NTC	3 S	X	X	X	X	X	X	X	X	X			
																																								Maximum heating time expired	Replace heating element	3 S									
																																											NTC defective	Replace cable	3 S						
Heating element defect	Replace heating element	3 S																																																	
			Connection heating element interrupted	Replace cable	3 S																																														
						Overheating: Temperature greater 88°C for a time longer than 5 min	Replace NTC	2 A	X																																					X	X	X	X	X	X
									NTC defective	Replace heating element	2 A																																								
												Cable defective	Replace cable	2 A																																					
															Heating element defect	Replace pressure switch antiboil 2	2 A	X																																	
																		Incongruence between antiboil 2 and relay	Replace cable	2 A																															
																					Heating element defect	Replace pressure switch antiboil 1	2 A																												X
																								Incongruence between antiboil 1 and relay	Replace electronic Replace cable	2 A																								X	X
																											Leakage current in the appliance too high.	Replace heating element or replace other components	7 A																						
																														No heating	Replace heating element	3 S																			
																																	Voltage value by heating relays out of limits (5V)	Replace cable	3 S																

Service Program

Fault indication by multifunctionsdisplay LCD

Fault code	Type of fault	Remedy	Alarm Code	No.	No.	No.	No.	No.	No.	No.	No.	No.
				1	2	3	4	5	6	7	8	
E70	E71	NTC short circuit	3	S	X	X	X	X	X	X	X	X
		NTC interruption										
	E74	NTC isn't in the correct position in the tub	3	S			X	X	X	X	X	X
E80	E82	Wrong selector reset position detection		A		X	X	X	X	X	X	X
	E83	Wrong selector reading	4	S		X	X	X	X	X	X	X
		Wrong configuration of the machine										
E84	E84	Recirc. pump sensing failure Input voltage always 0V or 5V	1	A	X					X	X	X
	E85	Recirculation pump defect	2	A	X					X	X	X
		Triac defective										
E90	E91	Interrupted communication between In/Output electronic and main electronic	0	A	X			X		X	X	X
	E92	Incongruence between In/Output electronic and electronic	1	A	X			X		X	X	X
E93	E93	Configuration error	1	A	X	X	X	X	X	X	X	X
	E94	Lost of cycle datas	1	A	X	X	X	X	X	X	X	X
E95	E95	Communication error between microprocessor and EEPROM	0	A		X	X	X	X	X	X	X
	E96	Incongruence between Hardw are-version and cycles configuration	0	A		X	X	X	X	X	X	X
E97	E97	Incongruence between selector and cycles configuration	0	A		X	X	X	X	X	X	X
		Replace electronic										
E98	E98	Incongruence between motor control board and electronic	0	A								X
		Replace electronic										
E99	E99	Connection between loudspeaker and In/Output electronic	0	A						X	X	
		Replace loudspeaker										
E9A	E9A	Firmware between loudspeaker and In/Output electronic not ok	0	A							X	X
		Replace In/Output electronic										
E9F	E9F	Communication error between motor control board and electronic	1,6	A								X
		Replace electronic										
		Replace wiring										

Service Program

Fault indication by multifunctionsdisplay LCD

Fault code	Type of fault	Remedy	Alarm Code	No.	No.	No.	No.	No.	No.	No.	No.	No.	No.								
				1	2	3	4	5	6	7	8										
EA0	DSP defect	Replace DSP, Replace electronic wiring, Cut drive belt	5 S	X	X	X	X	X	X	X	X	X	X								
				EA2	DPS sensing defect	Replace electronic	X														
							EA3	DPS unable to lock motor pulley	Replace DSP, Replace electronic wiring, Cut drive belt	X											
										EA4	DPS defect	Replace DPS	X								
													EA5	Triac for DPS defect	Replace electronic	X					
																EA6	Drum have blocked in the first ca. 30sec.	Cut drive belt, Replace DSP			X
EA6	Drum have blocked in the first ca. 3sec.	Drum lid not closed						X													
			EB0	Power supply frequency out of limits	Wrong or disturbed power supply line	0 A		X	X	X	X	X	X								
EB2	Power supply voltage too high	Replace electronic						X	X	X	X	X									
							EB3	Power supply voltage too low	Wrong or disturbed power supply line		X	X	X	X	X						
										EBE	Line Safe relay faulty	Replace electronic					X				
													EBF	Line Safe "sensing" faulty	Replace electronic				X		
																EC0	Inlet valve blocked	Replace inlet valve, Replace electronic wiring			X
EC2	Turbidity sensor defect	Replace turbidity sensor			X																
			EF0	Filter dirty	Cleaning drainhose and filter	S	X														
EF2	Detergent overdosing	Checking drainpump							X	X	X										
							To much foam during the drain phase	Cleaning drainhose and filter			X	X									
									Filter dirty	Checking drainpump			X	X							
EF2	Drainhose closed	Not overdosing																			

Service Program

Fault indication by multifunctionsdisplay LCD

Fault code	Type of fault	Remedy	Alarm Code	No.	No.	No.	No.	No.	No.	No.	No.	No.
				1	2	3	4	5	6	7	8	
EF3	Aqua Control system activated	Leakage in the machine	2	X			X	X	X	X		X
	Drain pump cable defective	Replace cable										
	Drain pump interruption	Replace drain pump										
EF4	No signal from flow meter with electro valves switched on	Water tap closed or mains pressure insufficient.	0					X				X
EF5	Interrupted the spinning phase Unbalance to high, unbalance >1200gr	Pay attention to the quantity of laundry, check stationary behaviour of washer	0									X
EH0	Power supply frequency out of limits	Wrong or disturbed power supply line Replace electronic	0									X
	Power supply voltage too high	Wrong or disturbed power supply line Replace electronic	0									X
	Power supply voltage too low	Wrong or disturbed power supply line Replace electronic	0									X
EHE	Line Safe relay faulty	2										X
EHF	Line Safe "sensing" faulty	2										X

Service Program

Rapid reading of alarm codes

The last alarm code can be displayed even if the programme selector is not in the 10th position (service test mode) or if the appliance is in normal operating mode (e.g. during the execution of an washing programme):

- Keep buttons 6 and 5 pressed in together.
- The last 3 error codes are indicated. The alarm sequence continues as long as the two buttons are held down. When releasing the keys the display will still stay for 10 sec.
- While the alarms are displayed, the appliance continues to perform the cycle or, if in the programme selection phase, maintains the previously-selected options in memory.

Indication of error code through LEDs

The error code is additionally indicated by the START/PAUSE LED.

The START/PAUSE LED is a double LED with colors orange and red.

When the orange LED is flashing (0.5 sec on, 0.5 sec off), the alarm family will be indicated, when the red LED is flashing afterwards, the alarm number will be indicated.

e.g. EA4

- **EA4** ---> orange LED flashes 10 x
- pause of 1.5 sec
- **EA4** ---> red LED flashes 4 x
- pause of 2.5 sec, then repetition



Alarm codes	flashing
1	1 x
:	:
9	9 x
A	10 x
B	11 x
:	:
H	17 x

Cancelling the last alarm

- Enter service test program (page 43)
- Press buttons 6 and 5 in together and keep them pressed in until the LCD E00.

It is good practice to cancel the last alarm:

- after reading the alarm code, to check whether the alarm re-occurs during diagnostics
- after repairing the appliance, to check whether it re-occurs during testing.

Demo-Programm

Activate the demo - program

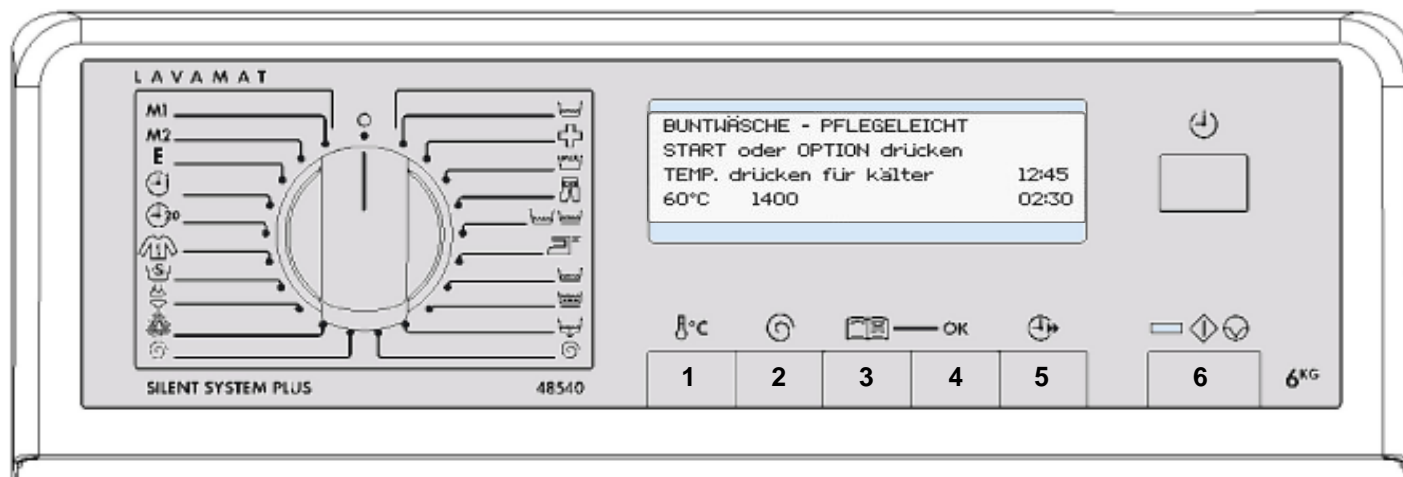

These appliances have a Demo-Mode for demonstration purposes.

main electronic EWM3500

Software **WEB101..**
WEC202..

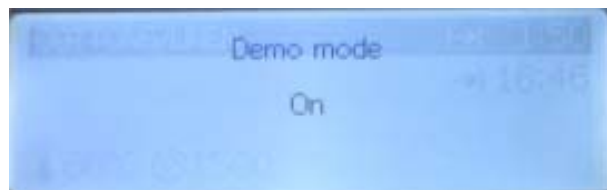

1. Access to demo program

- Switch off the appliance.
- Keep buttons 6 and 5 pressed in together and rotate the programme selector three positions to the right.
- Keep both selected keys pressed for about 2 seconds.
- You can select the individual programs and the associated option keys by using the program selector switch.
- The key start/pause is disabled.
- The demo program will remain in the memory even if the appliance is switched Off.

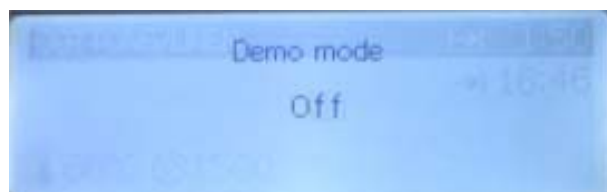

2. Adandoning the demo program

- Switch off the appliance.
- Keep buttons 6 and 5 pressed in together and rotate the programme selector three positions to the right.
- Keep both selected keys pressed for about 2 seconds.
- Switch Off the appliance to deactivate the demo program.

Electronic-Test

Activate the electronic-test

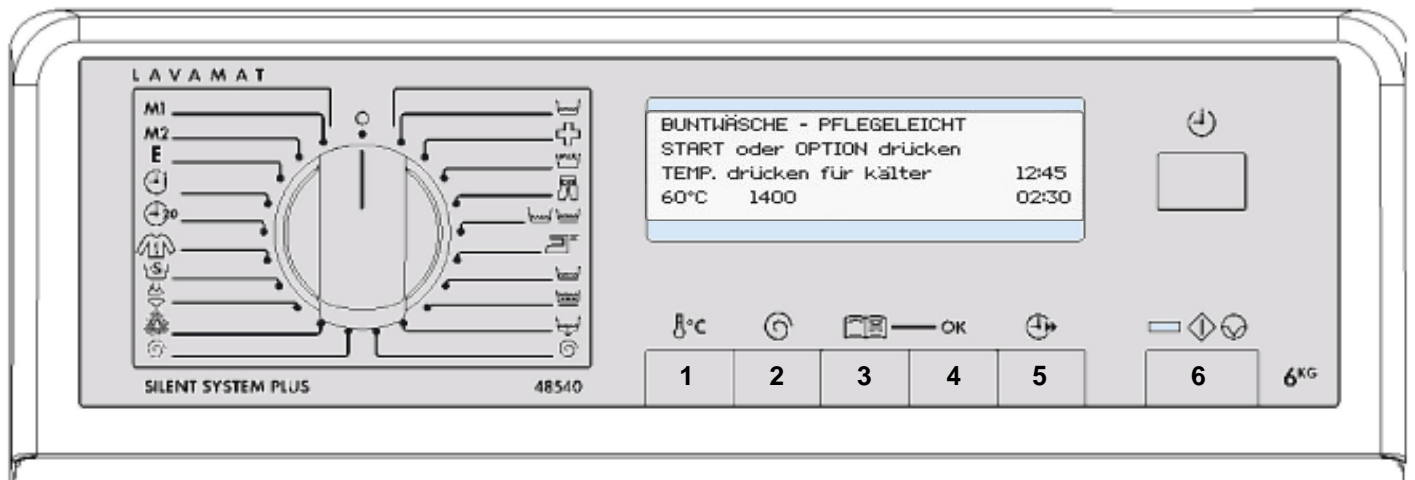

1. Access to the electronic-test

- Switch off the appliance.
- Hold buttons 6 and 5 pressed simultaneously and turn the program selector one position to the right.
- Keep both selected keys pressed for about 2 seconds.
- Hold buttons 6 and 5 together and pressed again.
- Switch off and on the appliance
- The display indicates „ELE“
- The electronic-test is running
 - Filling till 1. Niveau
 - Movement with 50 1/min.
 - Heating up to max. 50°C or 20min duration.

2. Abandoning the elektronik-test

- Switch off the appliance.

Operating time

Activate the operating time

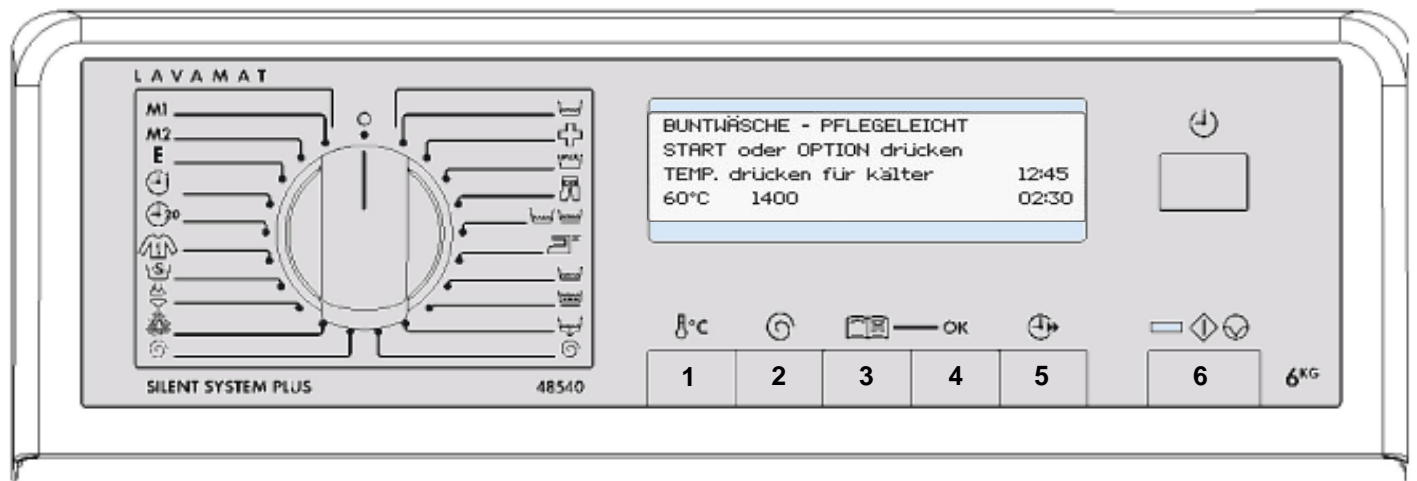

- 1. Access to the operating time**
 - Switch off the appliance.
 - Keep buttons 6 and 5 pressed in together and rotate the programme selector five positions to the right.
 - Keep both selected keys pressed for about 2 seconds.
- 2. Adandoning the operating time**
 - Switch off the applinace.

e.g. 1111 operating time

TC1

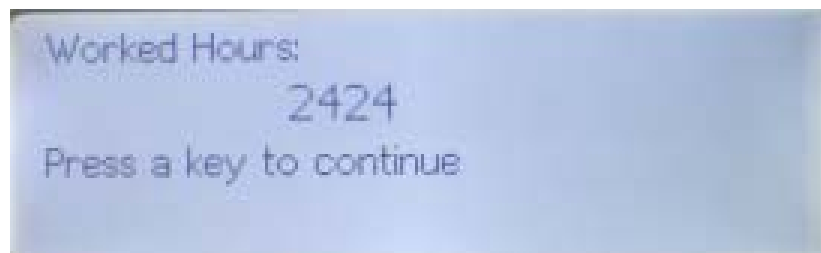

Circuit Diagram

Technical Specifications

GENERAL FEATURES

Supply voltage 230 V
Dimensions (height, width, depth) 85/40/60 cm
Dryclothes loading capacity 5,5 kg
Drum rotation speed (washing/spinning) 55/600-1500 r.p.m
Intermediate speed 1000 r.p.m
Intermediate speed 850 r.p.m

WATER LOAD CAPACITY (without clothes) :

Heating Level I 2 l
Heating Level II 2 l
Anti-overflow level 43 l

WATER PRESSURE :

Max./Min. 0,8/0,05 MPa

CONSUMPTIONS (COTTON 60°) :

see energie label

TECHNICAL PARTICULARS

DRAIN PUMP :

Maxi head 100 cm
Mini head 70 cm
Delivery rate 25 l/min
Power absorbed 30 W
Winding resistance 164/224 ohm

HEATING ELEMENT :

Power absorbed 1950 W
Resistance 27 ohm

WATER VALVE :

Delivery rate 5,5 l/min
Coil resistance 4300 ohm

CYCLING PUMP :

Delivery rate 12 l/min
Power absorbed 18 W
Winding resistance 200 ohm

DOOR INTERLOCK :

Type voltmetric
Internal door locking 0,02 s
Internal door release 0,02 s

DOOR INTERLOCK :

Type voltmetric
Internal door locking 6 s
Internal door release 40-120 s

WATERSAFETY SYSTEM :

Type 110539000

TEMPERATURE PROBE (NTC) 6 kohm at 20°C

PRESSURE SWITCH ANALOGIC :

Analogic Level 000 mm - 44,7 Hz
Analogic Level 300 mm - 36,1 Hz

USER INTERFACE : EWM3500

Identification mark 13254175.
Identification mark 13242475.

MODULE REGULATION SPEED : EWM3500

Module 13252771.
Supply voltage 230 V

DOOR POSITIONNING (electric):

Identification mark 146132000

DISPLAY LCD :

Serie 6-low 13254441.
Serie 6 13252918.
Serie 7 13252916.
Serie 7-high 13252903.
Serie 8 13254430.

ASYNCHRONOUS THREE-PHASE MOTOR :

Pulley ratio 12
Insulation class F
Spinning speed 17000 r.p.m
Winding resistance X (4-5) 5,5 ohm
Winding resistance Z (4-6) 5,5 ohm
Winding resistance Y (5-6) 5,5 ohm

TACHOGENERATOR :

Resistance (7-8) 119ohm

CONNECTION :

Water supply connection 1,5 m long
Water discharge connection height mini 70 / maxi 100 cm
Total power 2300 W

Circuit Diagram

Wiring Diagram

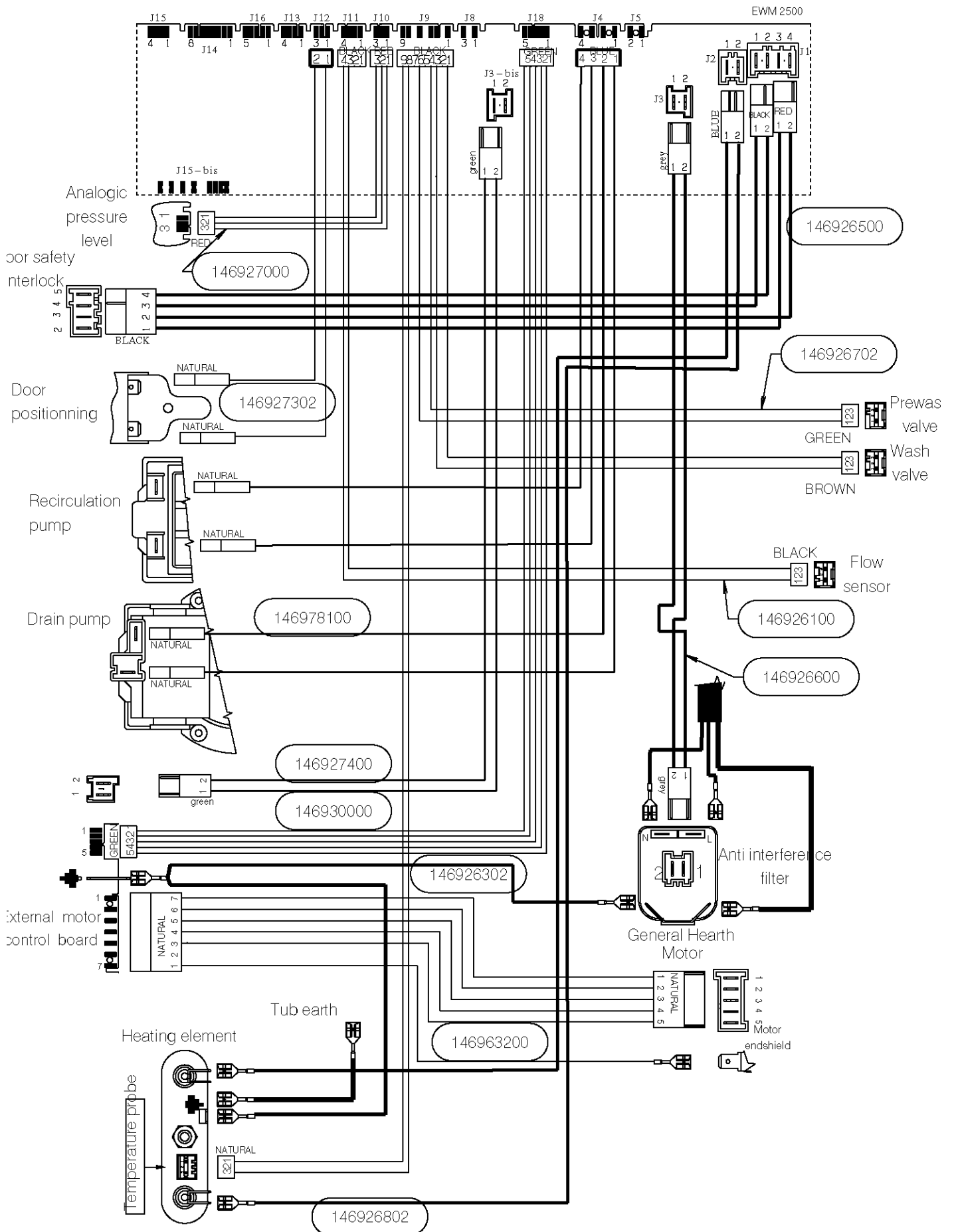

Circuit Diagram

Elementary Diagram

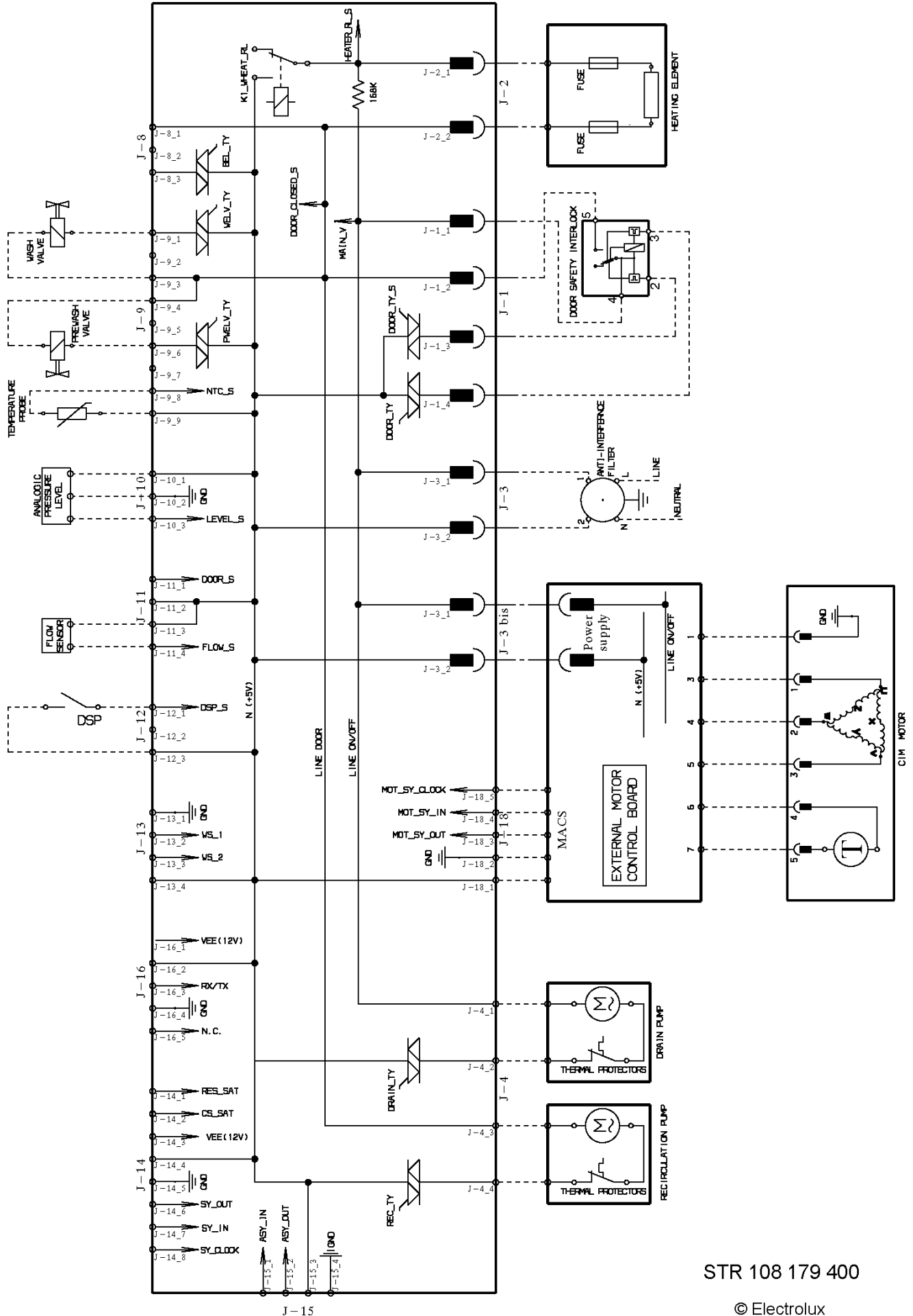

STR 108 179 400

© Electrolux

Program cycles

Cotton / Coloured 60° ECO (without options)

Software WEB101..

Software WEC202..

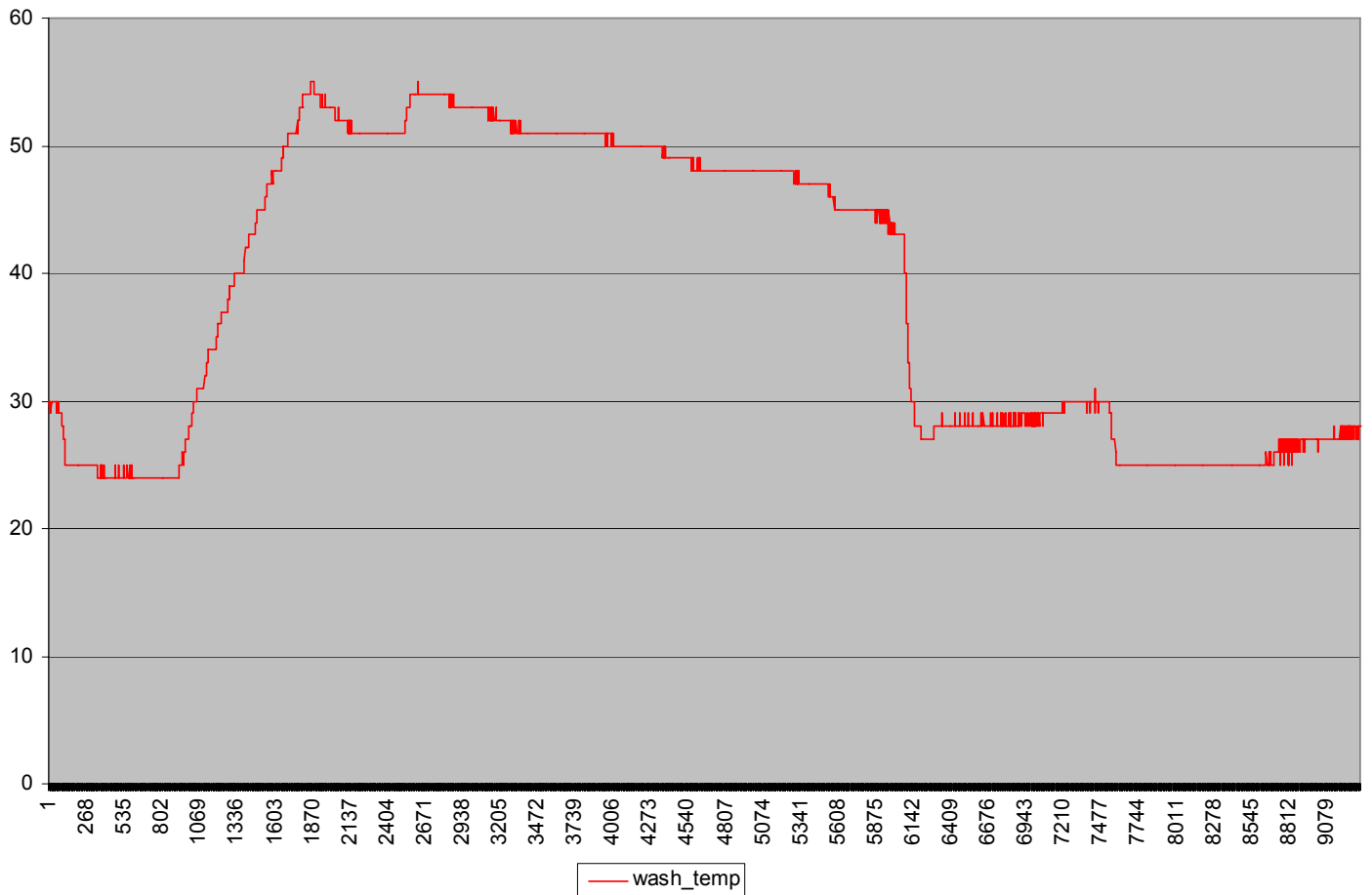
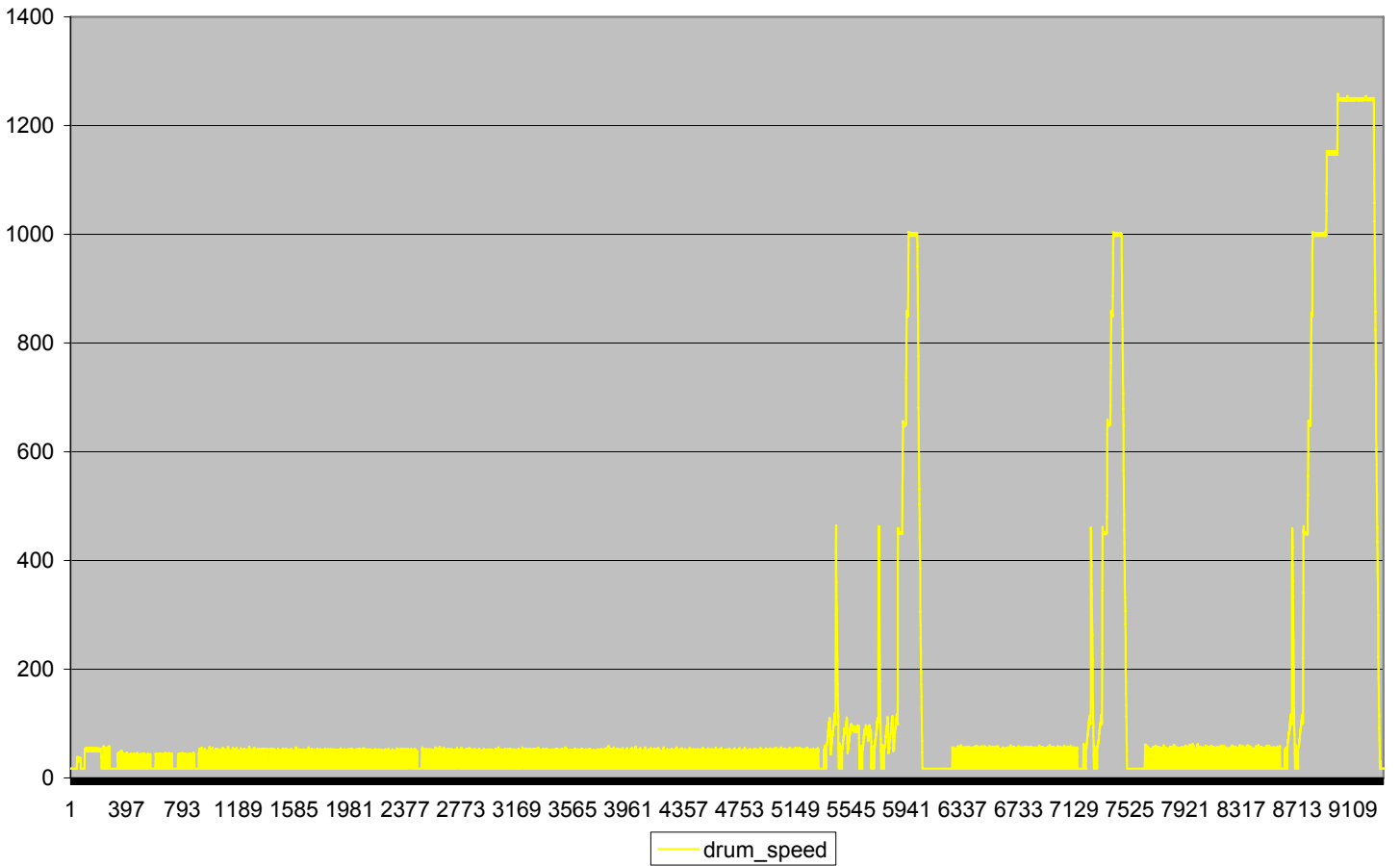

Program cycles

Cotton 60° (without options)

Software WEB101..

Software WEC202..

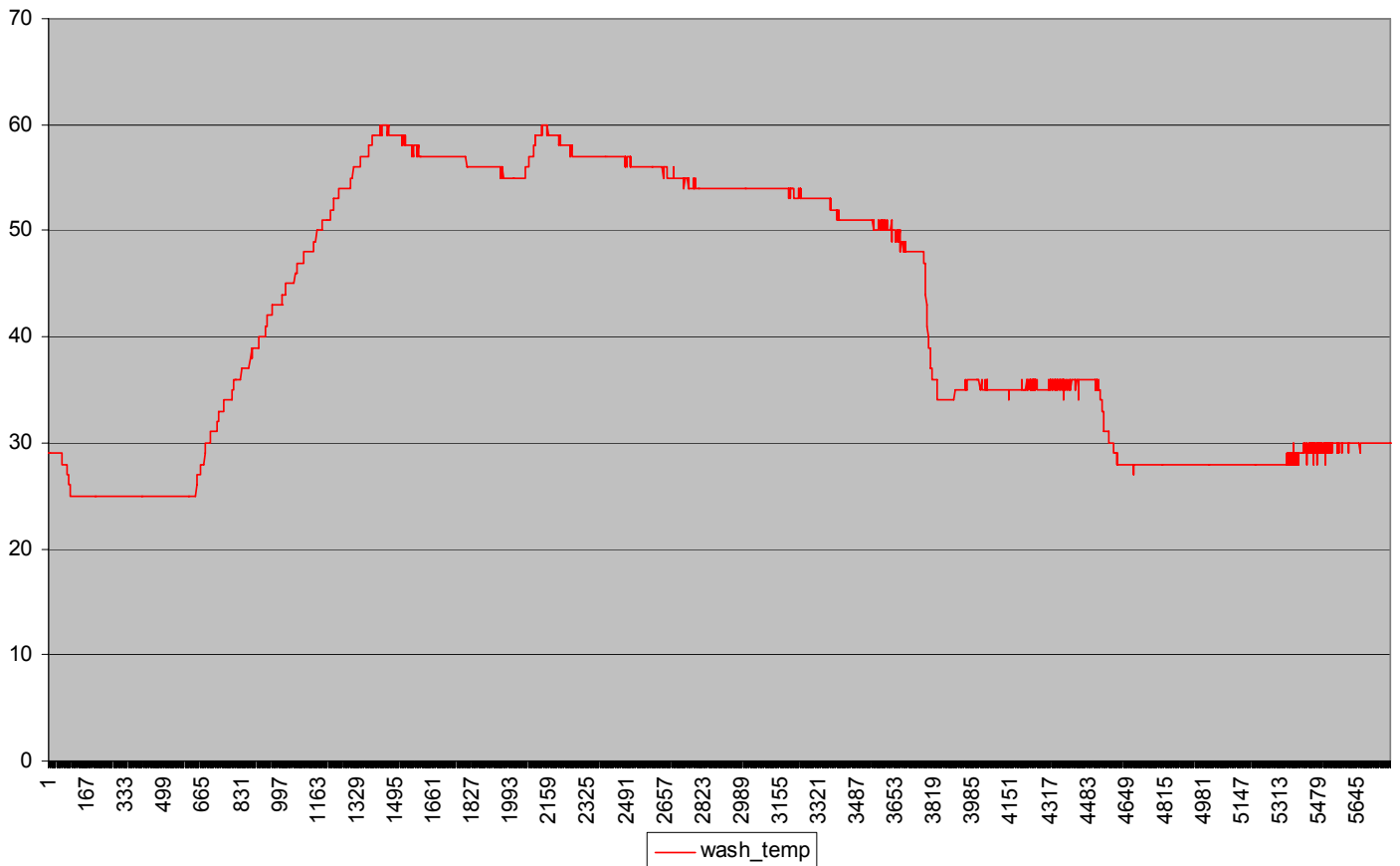
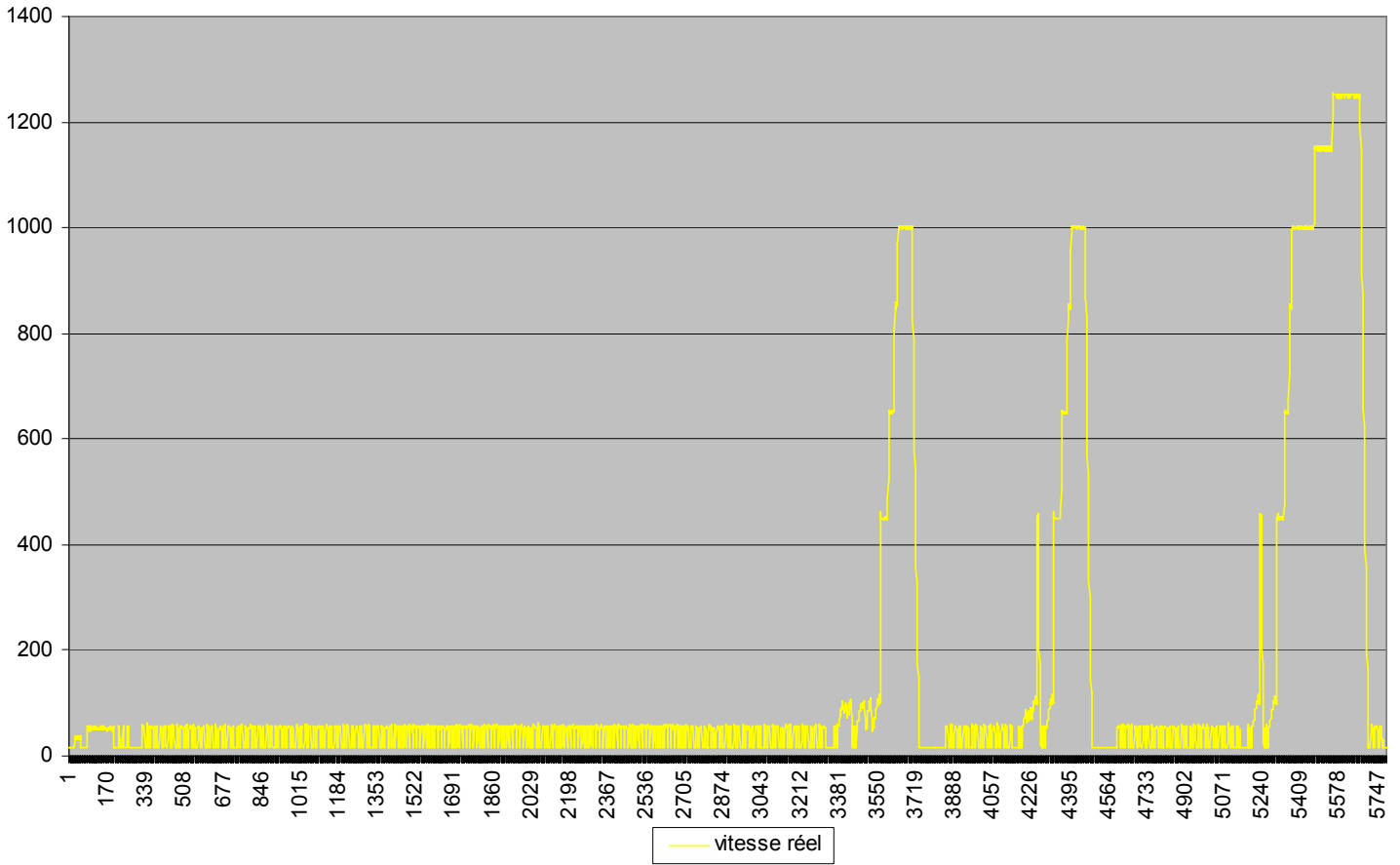

Program cycles

Cotton / Cloured 60° + Rinse+

Software WEB101..

Software WEC202..

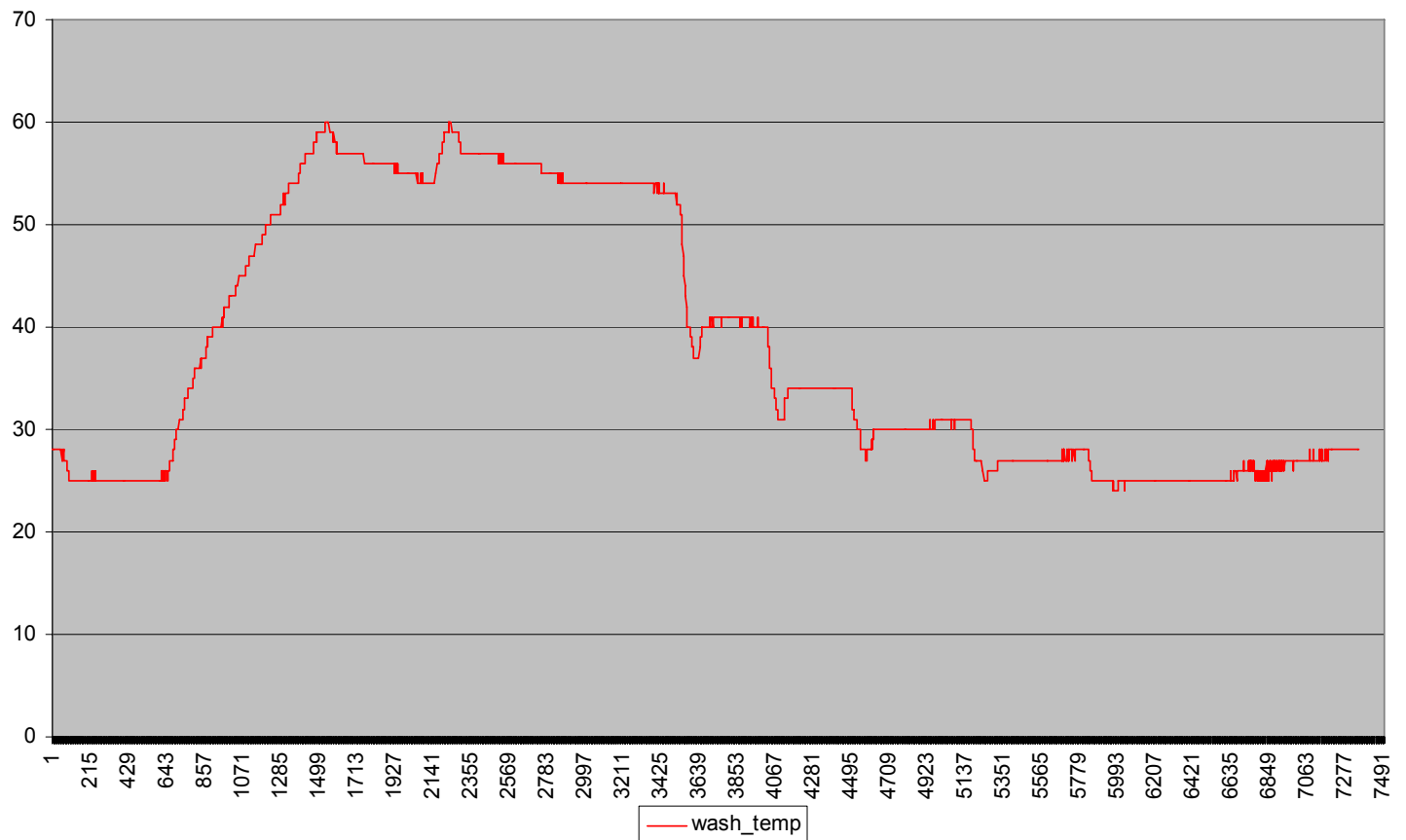
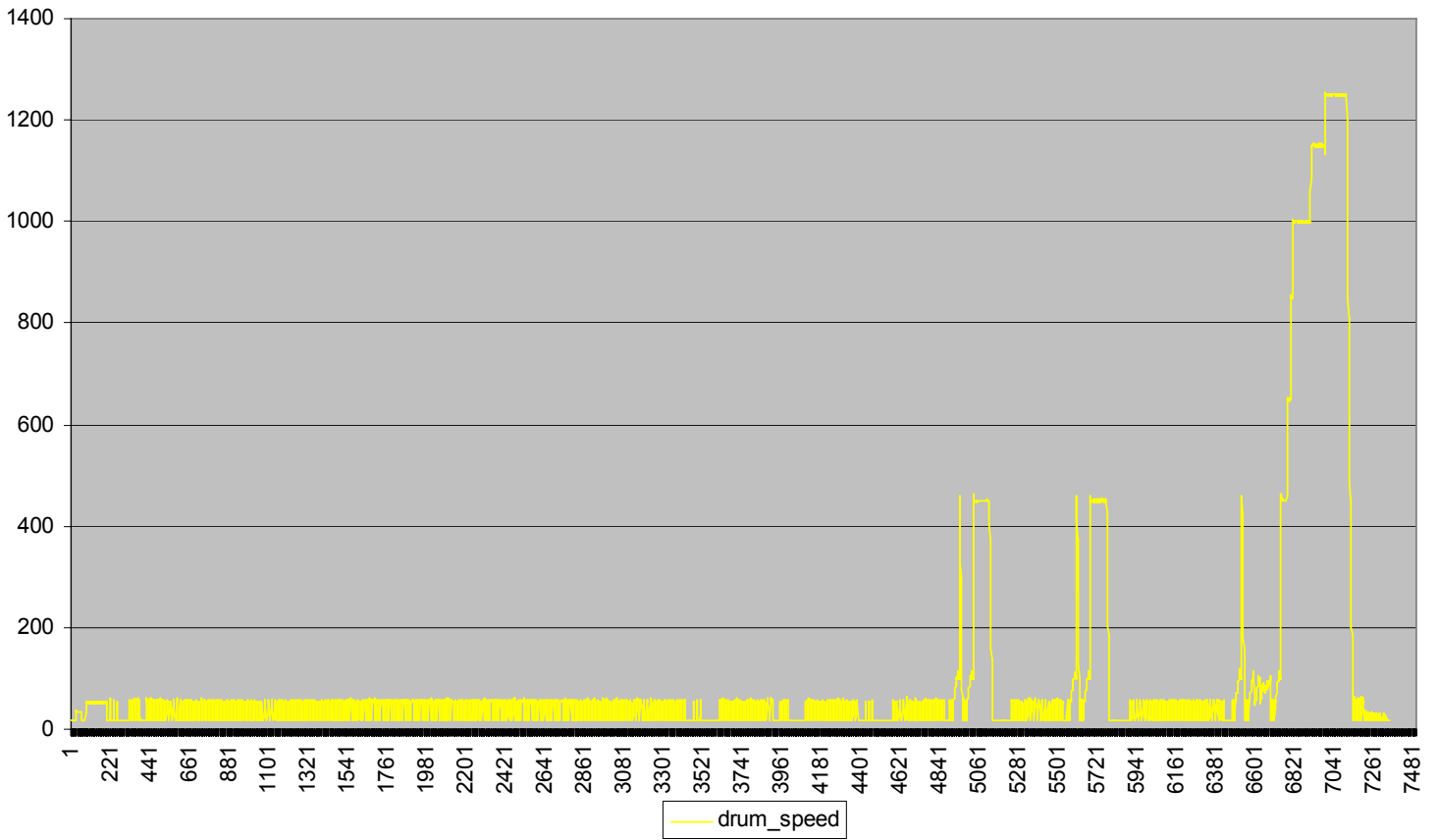

Program cycles

Cotton / coloured 60° ECO + Night cycle

Software WEB101..

Software WEC202..

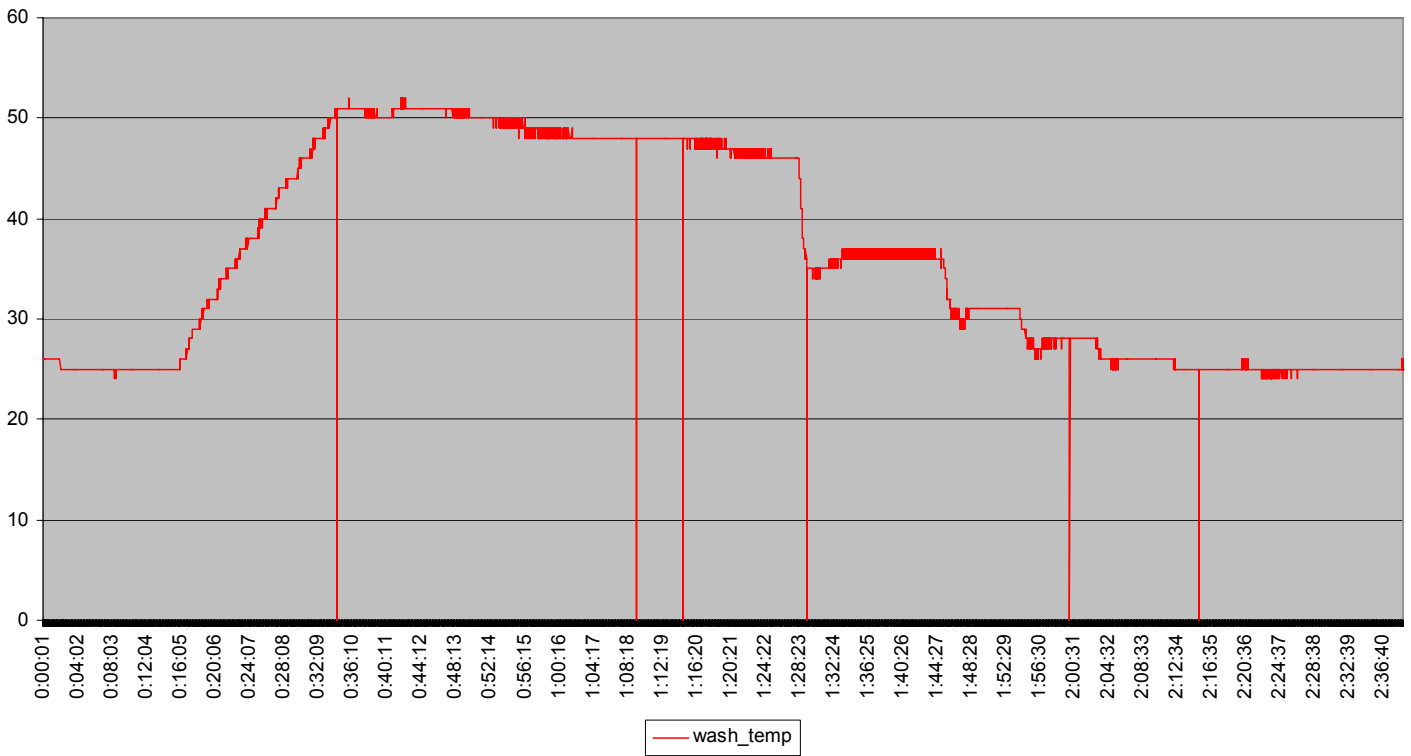
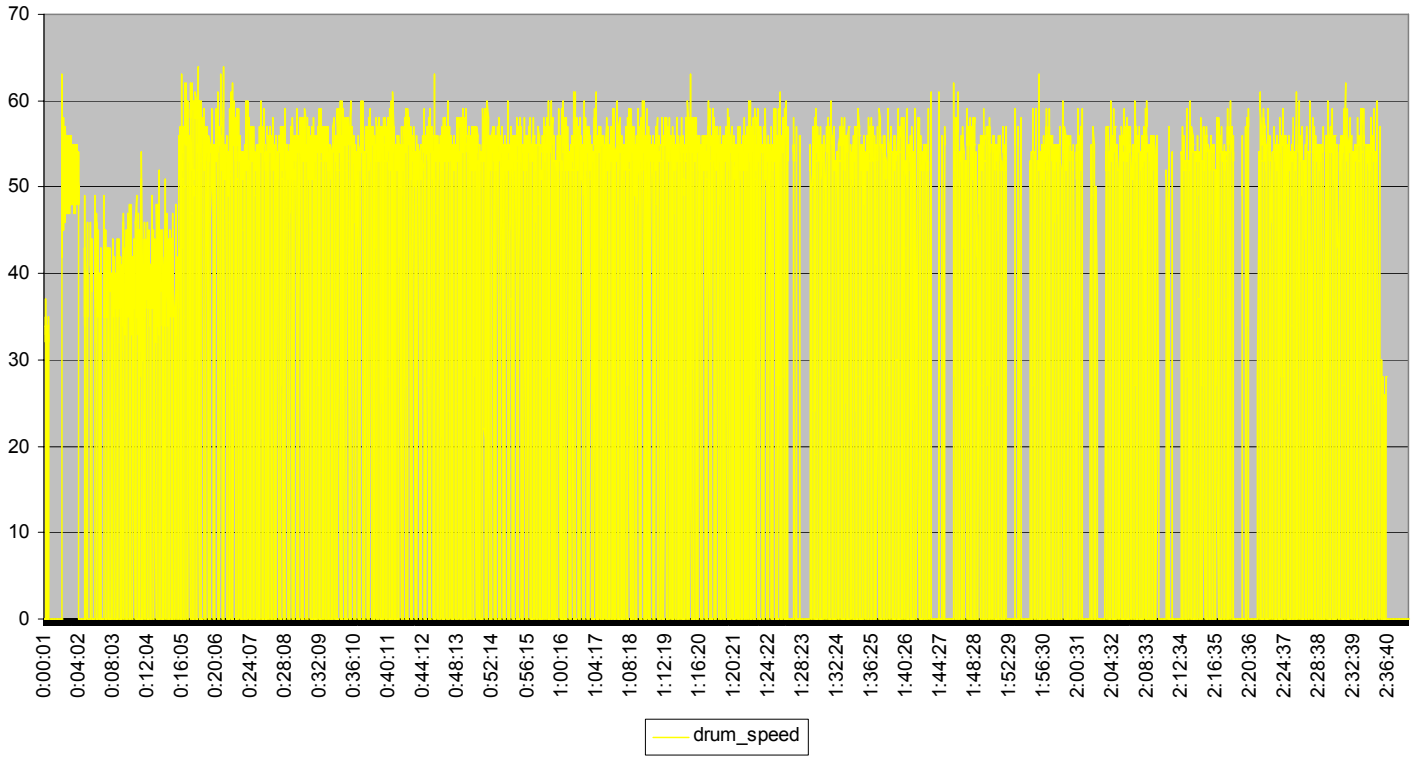

Program cycles

Synthetic 60° (without options)

Software WEB101..

Software WEC202..

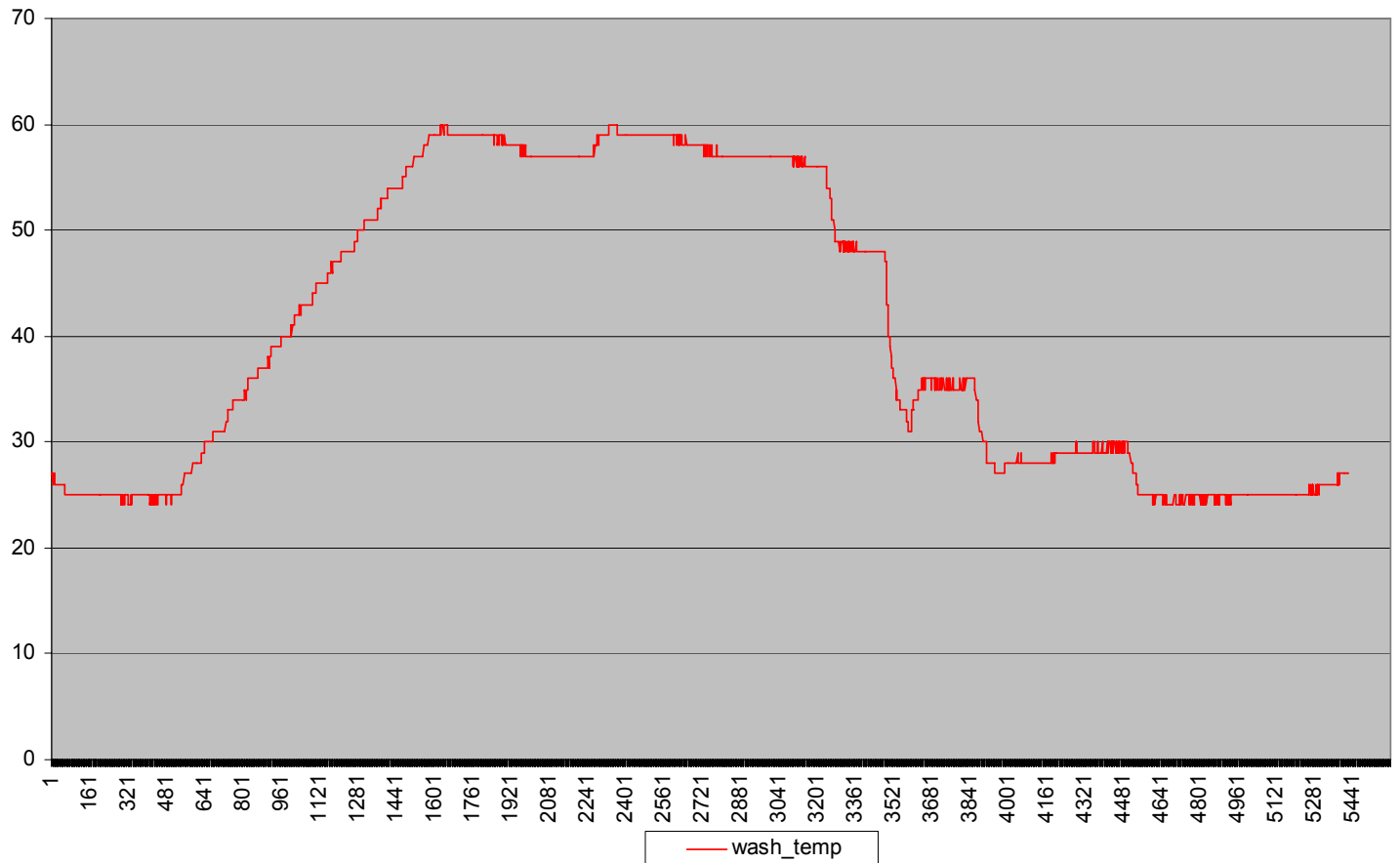
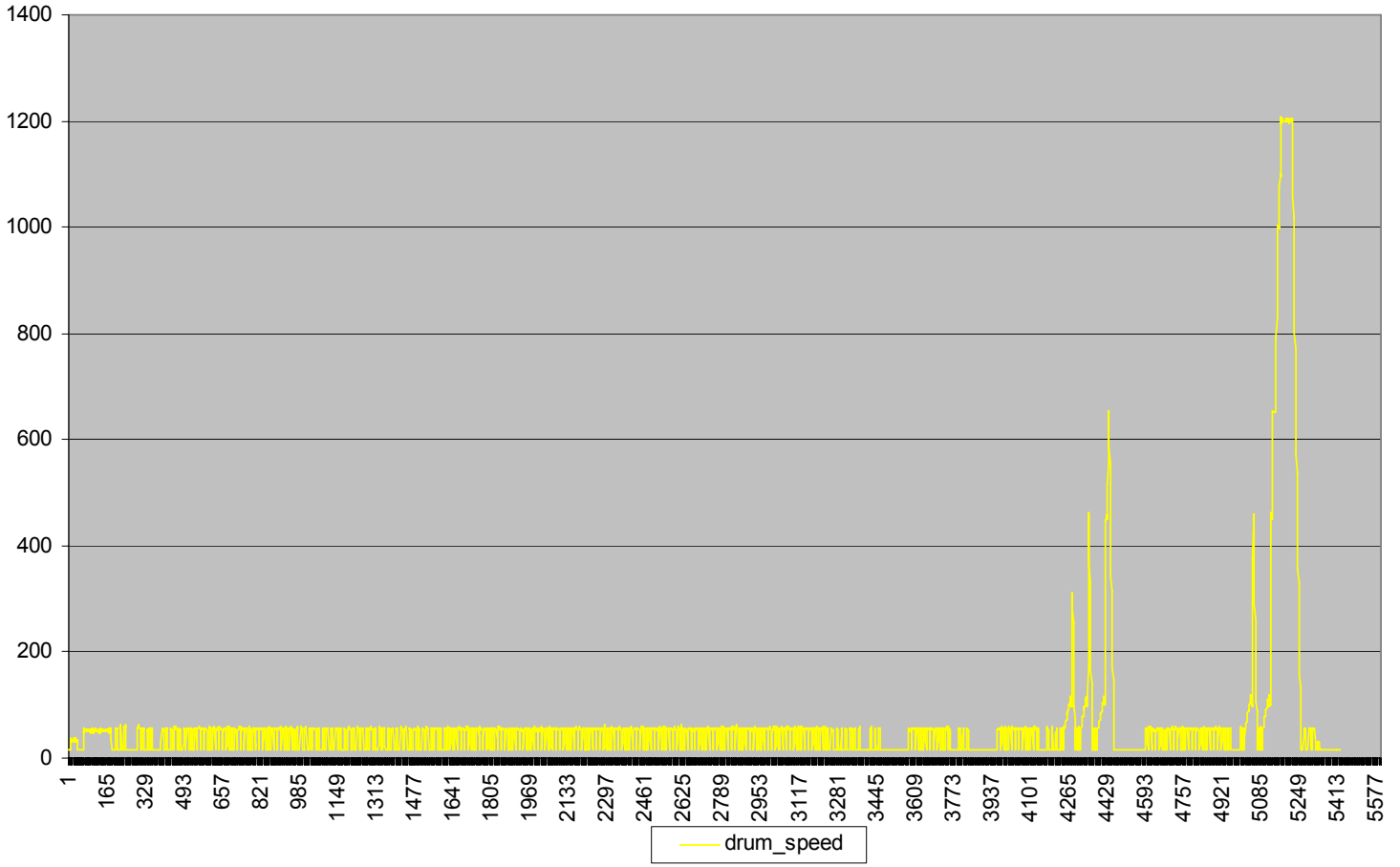

Program cycles

Delicates 40° (without options)

Software WEB101..
Software WEC202..

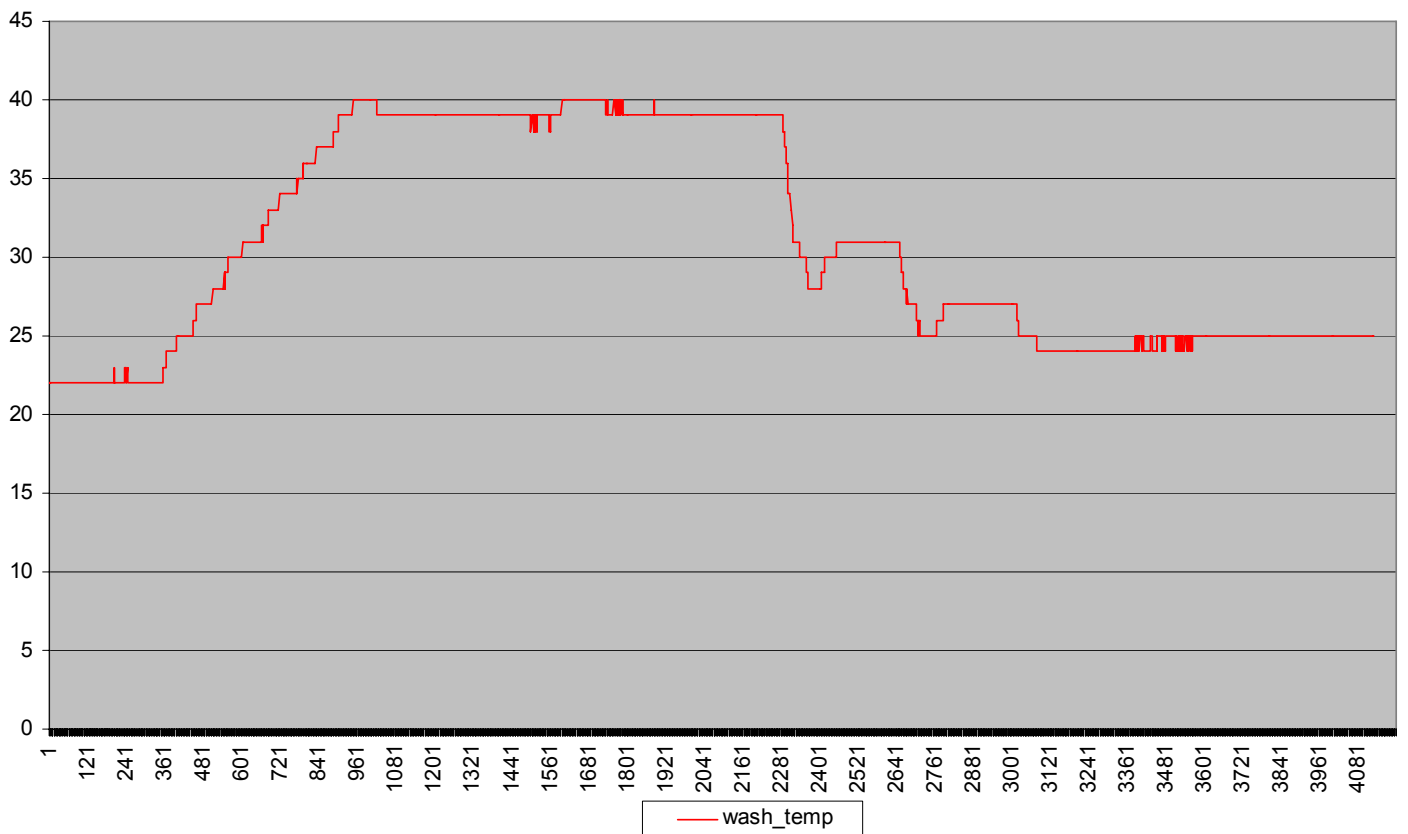
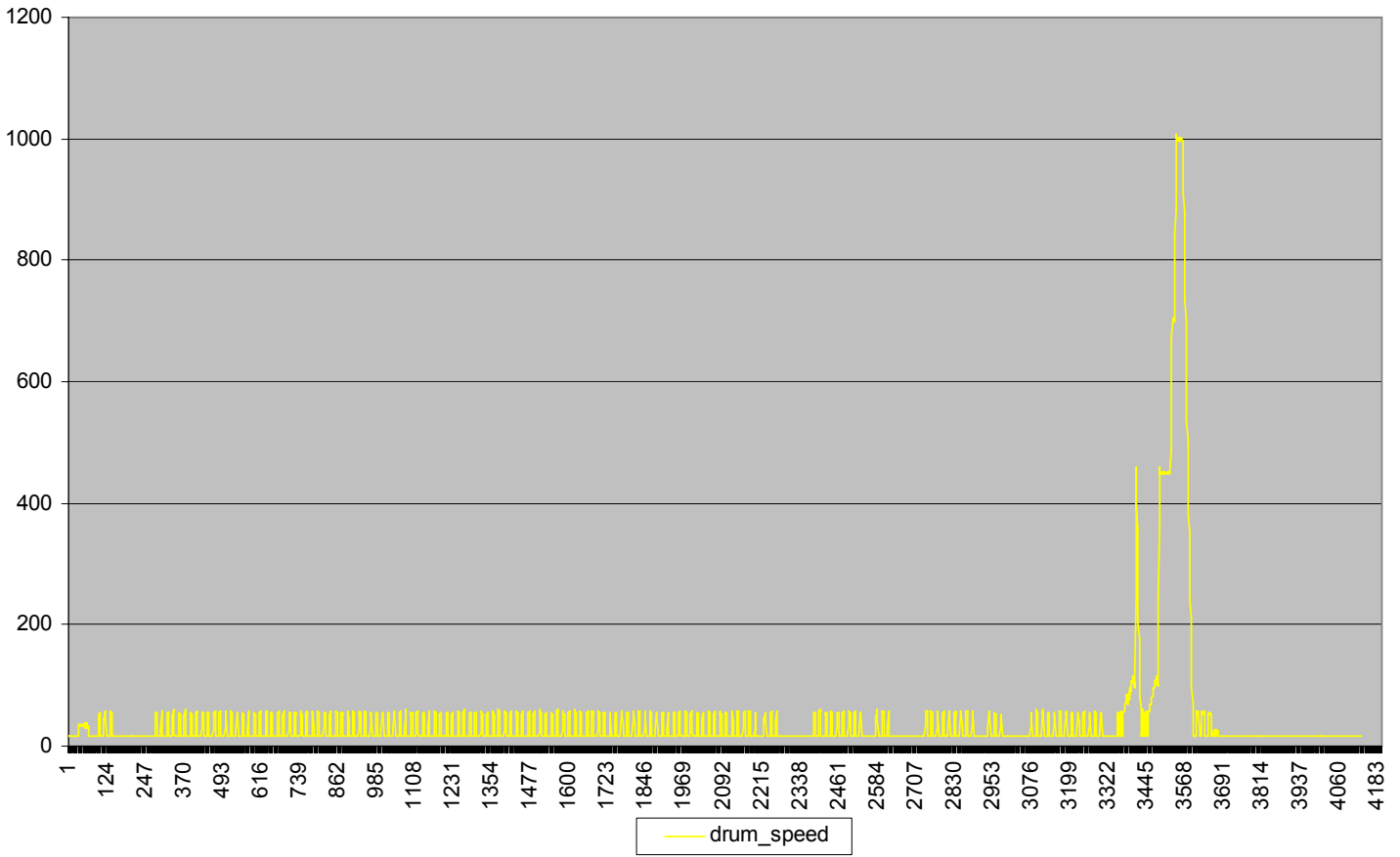

Program cycles

Wool 40° (without options)

Software WEB101..

Software WEC202..

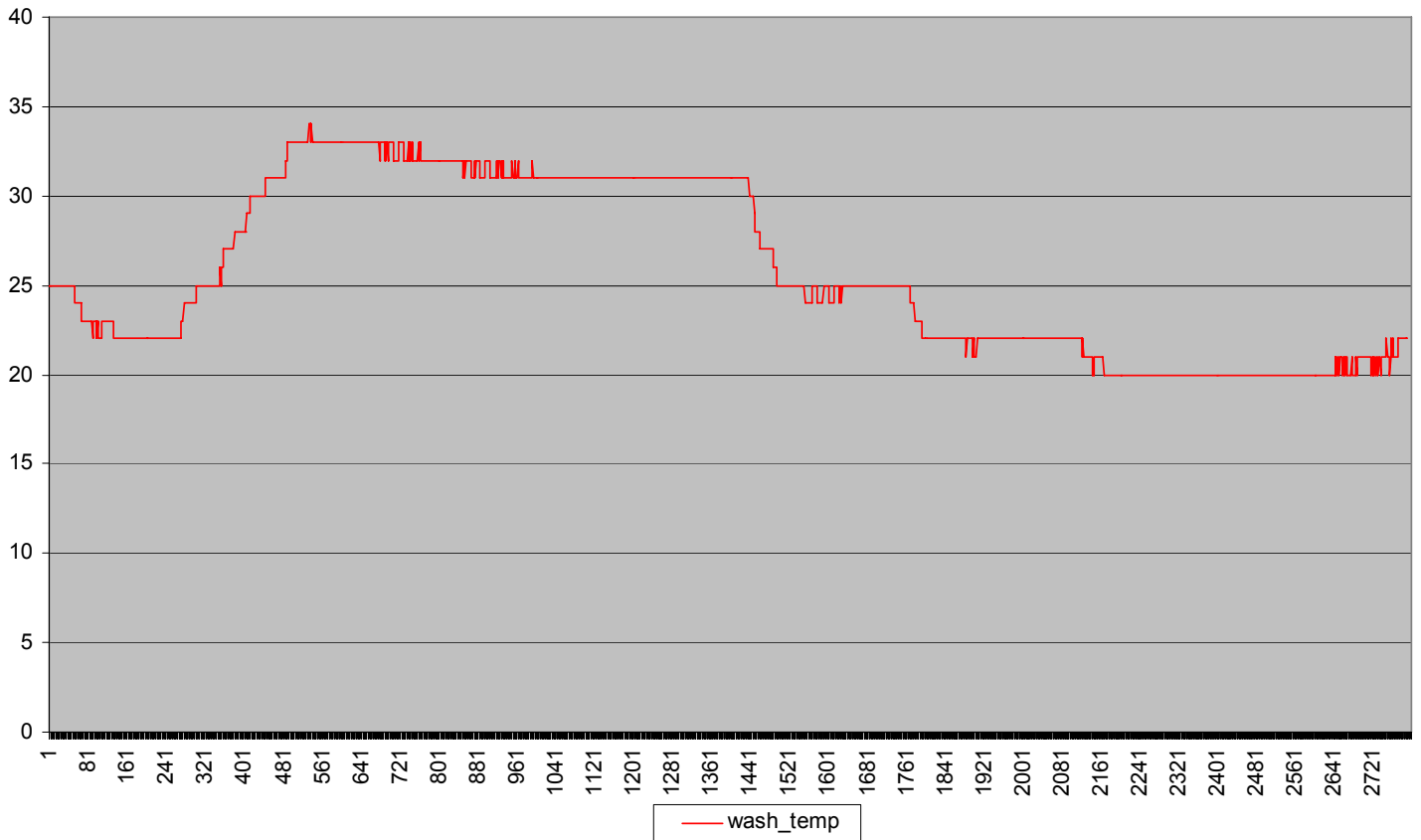
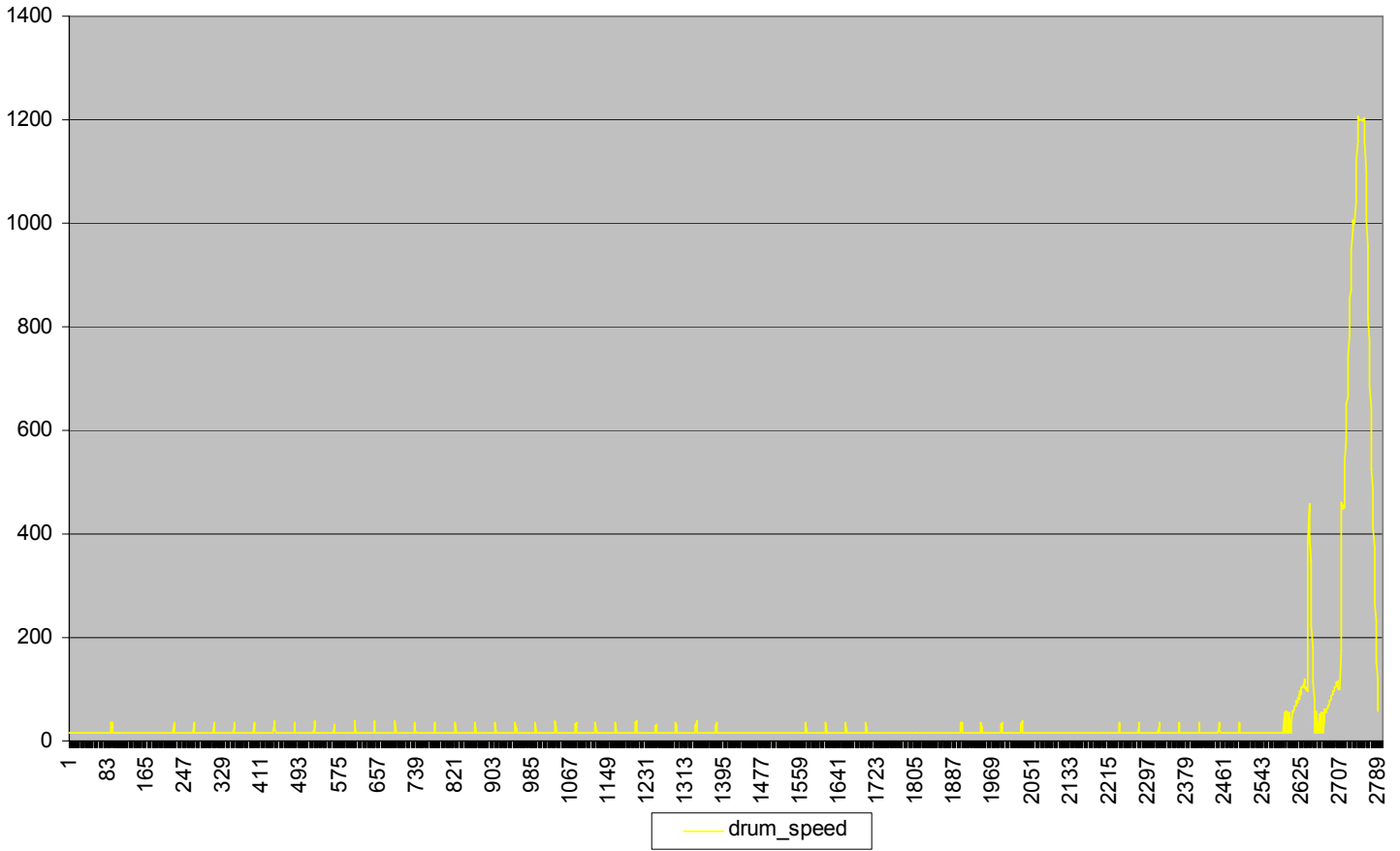

Changes

Date	Page changed
18.12.2006	23, 30, 37, 54
04.07.2008	9, 11, 15, 17