

**DISHWASHER
COMPACT
MIDI + EDW 500**

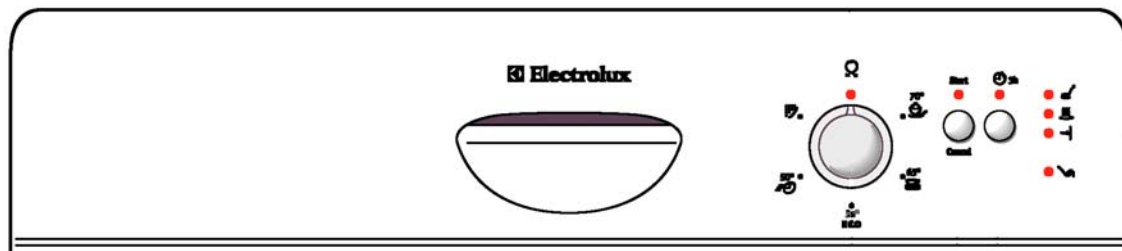

© AEG Hausgeräte GmbH
Muggenhofer Straße 135
D-90429 Nürnberg
Germany

Fax +49 (0)911 323 1420

Spares Operation
Edition: 02.05

Publ.-Nr.:
599 521 951
EN

Dishwasher
COMPACT
MIDI + EDW 500

Index

| | | |
|-----|---|---------|
| 1. | Technical data / Dimensions / Installation water drainage | 3 |
| 2. | Programs | 4 |
| 3. | Components | 5 |
| | Interference Filter | 5 |
| | Pressure Switch | 5 |
| | Flow Heater | 5 |
| | Circulation Pump | 6 |
| | Drain Pump | 6 |
| | NTC Temperature Sensor | 6 |
| | Electronic | 6 |
| | Detergent / Rinse Aid Combination Dispenser Unit | 7 |
| | Water Softening | 8 |
| | Setting of water Softening | 9 |
| 4. | Position of Components | 10 |
| 5. | Water Course Scheme | 11 |
| 6. | Leakage Protection | 12 |
| | Safety level | 12 |
| 7. | Water Inlet | 13 |
| 8. | Static filling | 13 |
| 9. | Washing | 14 |
| | Circulation system | 14 |
| | Heating | 14 |
| 10. | Regeneration | 15 |
| 11. | Rinse out after regeneration | 16 |
| 12. | Anti sifon | 16 |
| 13. | Drain | 16 |
| 14. | In- and Output elements | 17 |
| | Position of pushbuttons, LEDs and lamps | 17 |
| 15. | Service menu | 18 |
| | Service functions | 18 |
| 16. | Overview error displays | 19 |
| 17. | Service Tips / Replace of components | 21 - 27 |
| 18. | Wirings | 28 |
| 19. | Measurement Points | 30 |

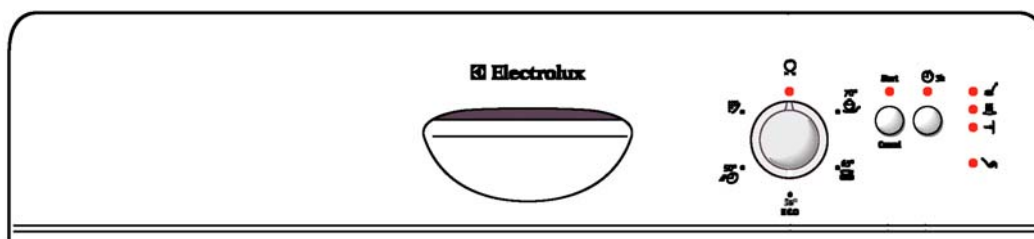

1. Technical data / dimensions

| | |
|---------------------|---|
| Volt: | 230 V |
| Frequency: | 50 Hz |
| Heating element: | 1100 W |
| Connected load: | 1200 W |
| Fuse required: | 10 A |
| Height: | 447 mm |
| Width: | 546 mm |
| Depth: | 480 mm |
| Noise: | 49 dB |
| Water pressures: | min. 80 KPa (0,8 bar) max. 1000 kPa (10 bar) |
| Inlet hose length: | 130 cm |
| Outlet hose length: | 130 cm |
| Cord length: | 170 cm |

Typical features for use

Compact dishwasher MIDI

| | |
|----------------|---|
| Wash programs: | Intensive 70, Normal 65, Normal Bio 50, Quick 50, Prewash extra |
|----------------|---|

Heating: flowheater

| | <i>Energie</i> | <i>Water</i> |
|-------------------|----------------|--------------|
| Intensiv 70 °C: | 1,15 kWh | 9 l |
| Normal 65 °C: | 0,80 kWh | 7 l |
| Normal Bio 55 °C: | 0,63 kWh | 7 l |
| Quick 50 °C: | 0,40 kWh | 6 l |
| Glas 40 °C: | 0,39 kWh | 6 l |

Installation water drainage

Place the discharge hose over the sink as illustrated.

It may not at any point be higher than 75 cm over the surface which the dishwasher is standing on. If runs higher, operation of the dishwasher might be impaired.



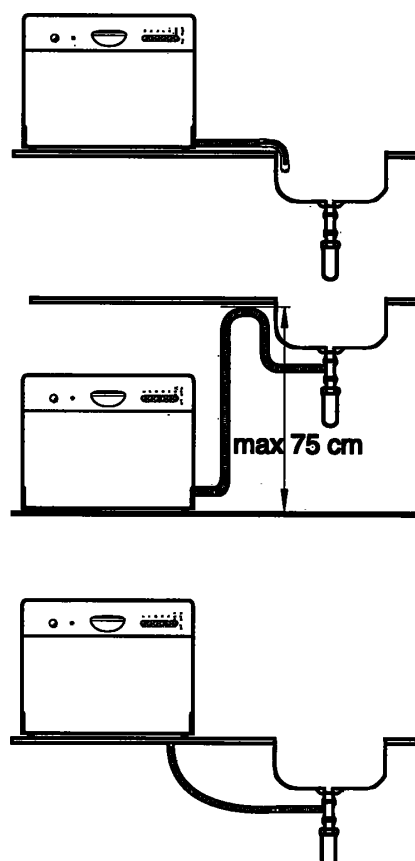

It is also important to ensure that the inside diameter of the hose is not less than 13 mm at any point. If the discharge hose is too long it can easily be cut to the right length.

Cut the hose to a suitable length, using a sharp knife.

Fit the elbow supplied onto the end of the hose.



2. Programs

| Type of dishes | Plates and cooking pots | All types of dishes | | Coffee cups, delicate items | All types of dishes |
|----------------------------------|--|---|---|--|---|
| Type of soil: | * heavily soiled * dried-on food remnants especially egg-white and starch | * normally soiled * dried-on food remnants | * normally soiled | * lightly soiled | *3) |
| Suitable programme: | ↓ | ↓ | ↓ | ↓ | ↓ |
| |  INTENSIVE 70 C |  NORMAL 65 C | ECO ENERGY SAVE 55 C 2) |  QUICK 50 C |  PRERINSE - |
| Programme cycle: | Pre-wash Washing 2 x rinses Final rinse Drying | Pre-wash Washing Rinse Final rinse Drying | Pre-wash Washing Rinse Final rinse Drying | - Washing Rinse Final rinse - | Prerinse - - - - |
| Consumption figures: 1) | ↓ | ↓ | ↓ | ↓ | ↓ |
| Washing time with drying: | 112 minutes | 92 minutes | 150 minutes | 35 minutes | 7 minutes |
| Drying time: | 13 minutes | 13 minutes | 54 minutes | — | — |
| Energy: | 1,15 kWh | 0,80 kWh | 0,63 kWh | 0,40 kWh | 0,01 kWh |
| Water: | 9 litres | 7 litres | 7 litres | 6 litres | 1,8 litres |

1) Consumption figures have been calculated for nominal conditions. The figures can vary depending on inlet water temperature and how full the main and cutlery basket are.

2) Consumption figures and performance is according to the Energy Save programme cycle.

3) Prerinse is used if you want to wait until you have a full load. This cycle rinses the load and keeps it moist, making the main wash easier later on. No detergent should be used.

All programmes begin with a drain.

Dishwashing detergent in tablet form is not suitable for use in the Quick programme cycle because some tablets cannot develop their full cleaning power during short programmes.

3. Components

Interference Filter

The interference filter is connected in the terminal board parallel to the mains feed.



Pressure Switch

The pressure switch controls the water level. Without water, contact is closed.

fN Switch point with level
 Reset point with level

45 mm Ws
10 mm Ws

The pressure switch is not adjustable.



Flow Heater

The flow heater heats the water to the required temperature. During the wash cycle, water is constantly passing through the flow heater.

| | |
|--------------|-----------------|
| Power output | 1100 W |
| Resistor | 45 Ω |
| Protector | 98 °C \pm 5 K |
| Thermal fuse | 260 °C |



Circulation Pump

The circulation pump is driven by an asynchronous motor with an auxiliary winding.

The auxiliary winding is in circuit with a 2,5 uF capacitor.

Speed for rinsing:
2800 1/min

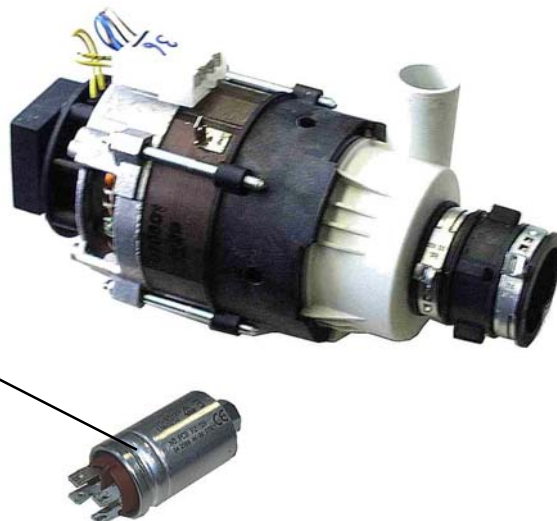

Drain Pump

The drain pump is driven by a synchronous motor.

Power output 26 W.

Pump rate 15 l/min.



NTC-Temperaturfühler

| NTC-Temperaturfühler | |
|--|----------------|
| Temperature sensor NTC-resistor | |
| Temperatur/Widerstand | 20 °C / 6032 Ω |
| temperature/resistor | 25 °C / 4829 Ω |
| (nur bei vollelektron. | 30 °C / 3891 Ω |
| Geschirrspüler) | 40 °C / 2573 Ω |
| (only for fully electronic dishwasher) | 50 °C / 1741 Ω |
| | 55 °C / 1444 Ω |
| | 60 °C / 1204 Ω |
| | 65 °C / 1009 Ω |
| | 70 °C / 849 Ω |



Electronic

On electronic models, a micro processor controls all components, this is done using triacs. The electronic also memorizes all programme data.

The heating is switched by a relay on the electronic board.

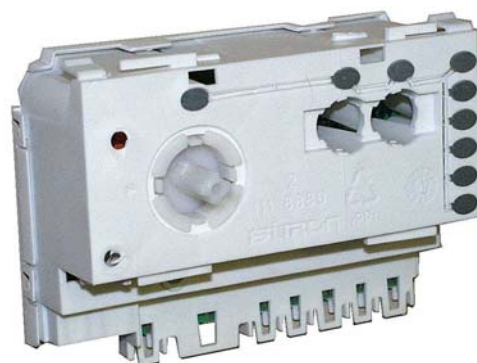

Detergent / Rinse Aid Combination Dispenser Unit

| | | |
|---------------------|----------------|-------------|
| Dosing of detergent | prewash | 10 ml |
| | wash | 20 – 30 ml |
| Dosing of rinse-aid | position 1 – 6 | 2 ml – 7 ml |
| Capacity | | 140 ml |

The detergent dispenser is activated by a release coil.

The first operation adds the detergent, and the second the rinse aid. If the door is opened, the latching bar is reset to the detergent dosage position.



The detergent compartment 1 is filling corresponding to the set dosing quantity when the door is open. Possibly existing rinse-aid in compartments 2 and 3 flows back into the storage tank of the rinse-aid. The detergent trays are filled up. The door will be closed and the detergent for prewash will be rinsed out through the slots in the detergent dispenser cover.

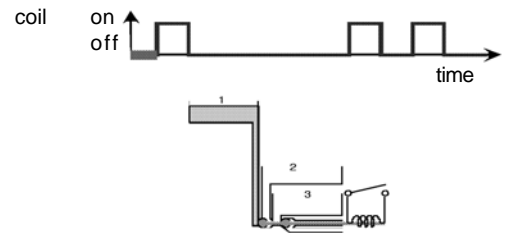

During the washing cycle the coil is switched on and the detergent compartment cover releases the detergent. The rinse-aid flows from compartment 1 into compartment 2.

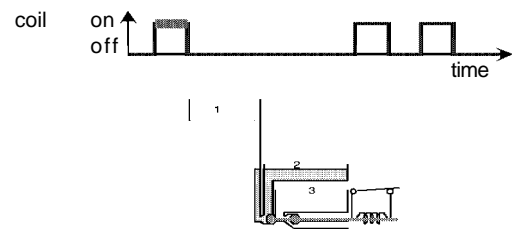

After switching off the coil, the rinse-aid flows from compartment 2 into compartment 3.

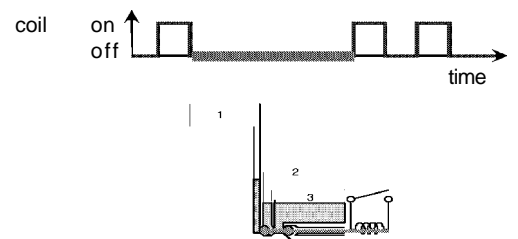

During the rinse cycle, the coil will be switched on when the rinse is warmed and the rinse-aid runs from compartment 3 into the rinse tank. At the same time, the remaining rinse-aid (15 %) runs from compartment 1 into compartment 2.

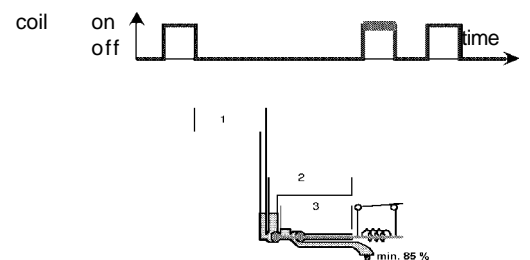

With the coil switched off, the rinse-aid flows from compartment 2 into compartment 3.

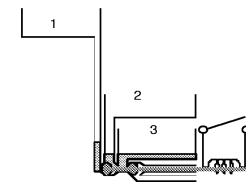

During the rinse cycle, the coil is always switched on twice. When it is switched on the second time, the remaining rinse-aid flows into the rinse tank.

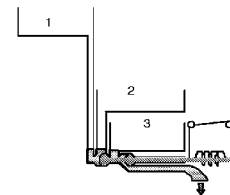

Water Softening

The components required for water softening.

1. softener unit
2. regeneration dosage chamber

The incoming water flows through the softener which works according to the ion exchange principle. The ion exchanger is filled with small epoxy resin balls. The resins exchange the hardness constituents (calcium and magnesium), for sodium ions.

When all the sodium ions are used up, it is necessary to regenerate the softener. This is done by flushing a brine solution through the softener.

Afterwards the softener is washed out with fresh water and is now fully effective.

Depending on the water hardness, regeneration is only necessary after several wash cycles.

The softening system is designed for a water hardness of up to 50 °dH.



Customers menu: Water hardness

With this procedure it is possible to modify the regeneration level selection (depending on the water hardness).

Regeneration selection

To activate the function:

1. Press and hold down button **S1**.
2. Turn the knob to **Position 1**:
 - The LEDs LD0 and LD1 flash
 - Release button **S1**
3. Press button **S1**
 - The regeneration level is displayed by the **End of cycle** LED which flashes and pauses at intervals: for the decodification, see summary table of alarms.

Press button **S1** to increase the regeneration level according to the following values:

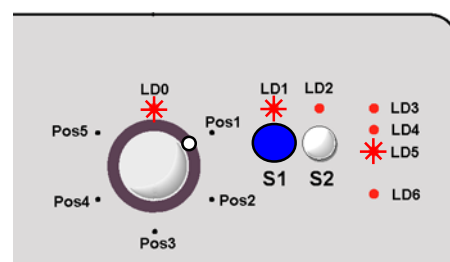
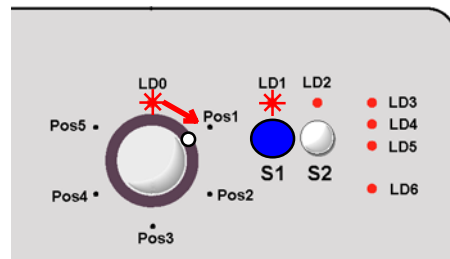

| Water hardness level id 1) | | Setting on the water softener | Number of light flashes |
|-------------------------------|-----------|----------------------------------|----------------------------|
| | mmol/l 2) | | |
| > 24 | > 4,2 | 10 | 10 |
| 22 - 24 | 3,9 - 4,2 | 9 | 9 |
| 20 - 22 | 3,6 - 3,9 | 8 | 8 |
| 18 - 20 | 3,2 - 3,6 | 7 | 7 |
| 16 - 18 | 2,8 - 3,2 | 6 | 6 |
| 13 - 16 | 2,3 - 2,8 | 5 | 5 |
| 10 - 13 | 1,8 - 2,3 | 4 | 4 |
| 7 - 10 | 1,2 - 1,8 | 3 * | 3 |
| 4 - 7 | 0,7 - 1,2 | 2 | 2 |
| below 4 | below 0,7 | 1 no salt is needed | 1 |

1) german degree of measurement for the water hardness

2) millimol, international unit for water hardness

*) factory setting

4. Position of components

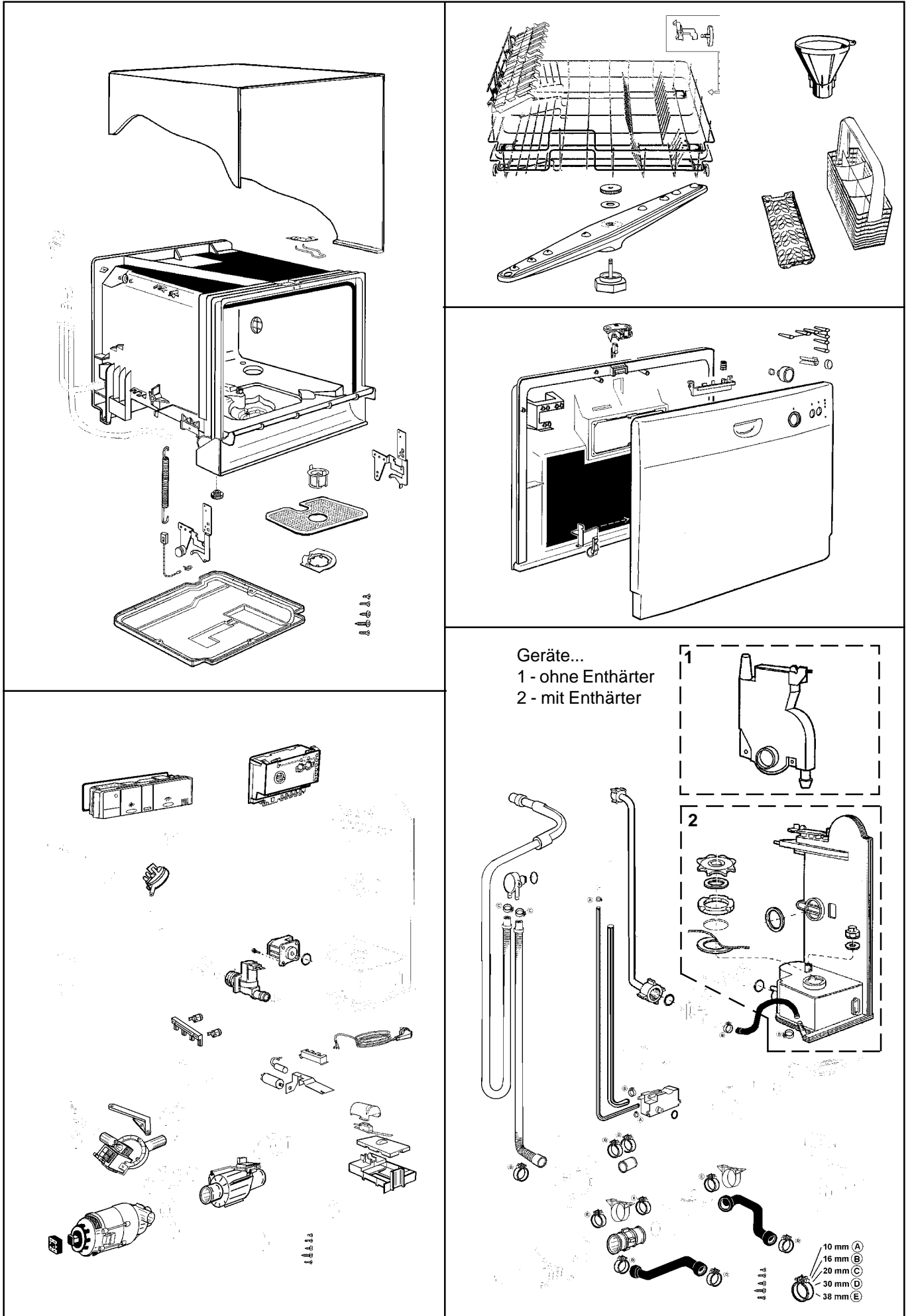

5. Water Course Scheme

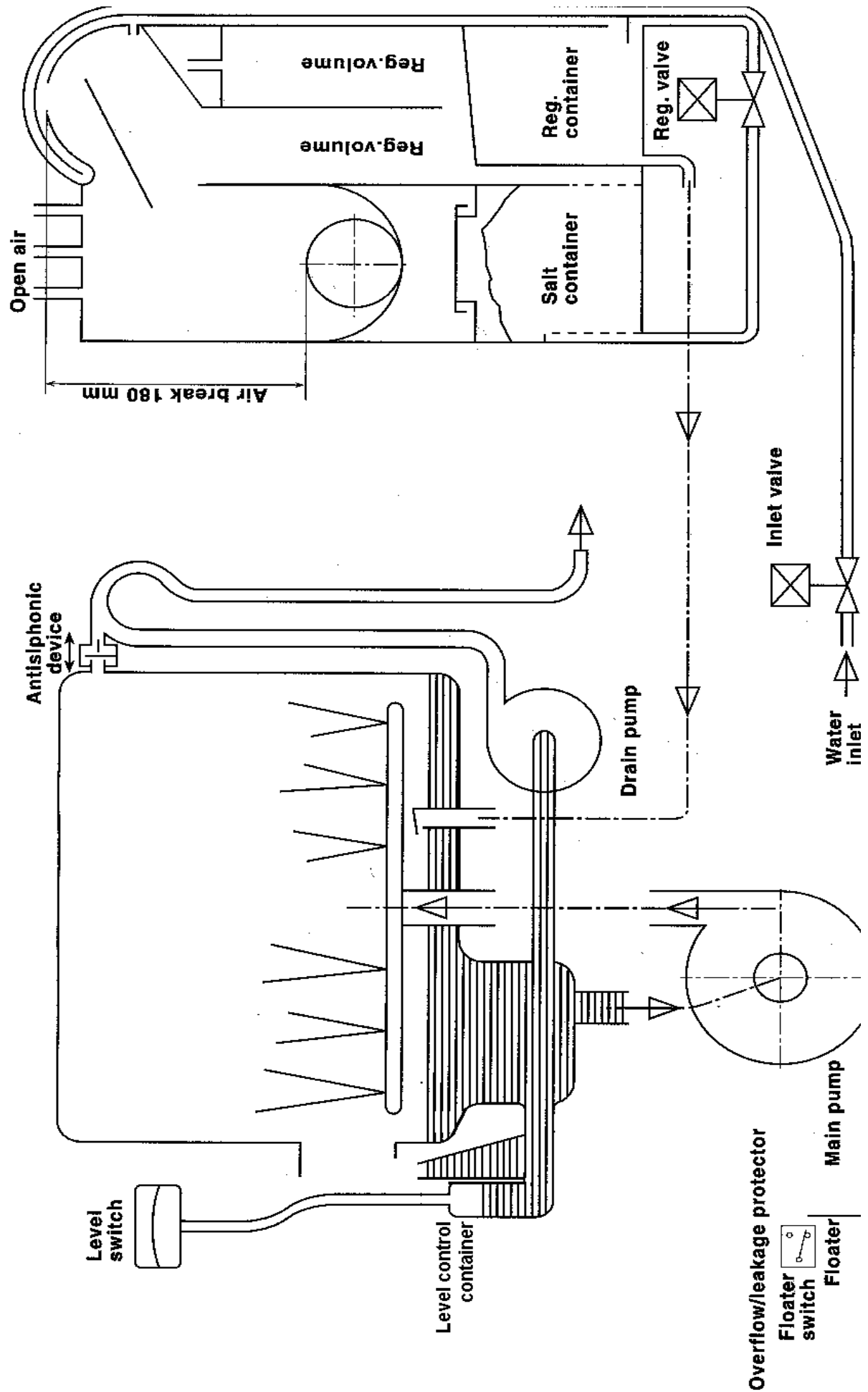

6. Leakage Protection

The anti-flood switch in the base tray will activate the drain pump and drain the water from the tub in the event of an internal leakage.

If the float switch is activated, all electric components are switched off except the drain pump.

Overflow protection

The filling phase fills up to the level, monitored by a pressure monitor. If the pressure monitor does not switch in, this filling phase is generally limited electronically to 2 minutes.

If the pressure monitor has not switched in by then, the electronics jump to the error mode "shut off tap", and the program is stopped.

If the pressure monitor switches back during the cycle, a maximum of 10 sec. further filling is possible. If the pressure monitor has not switched in by then, the electronics jump to the error mode "shut off tap", and the program is stopped.

Safety level

If the safety level is reached by over-filling more than 3,2 litres, floater switch starts the drain pump.

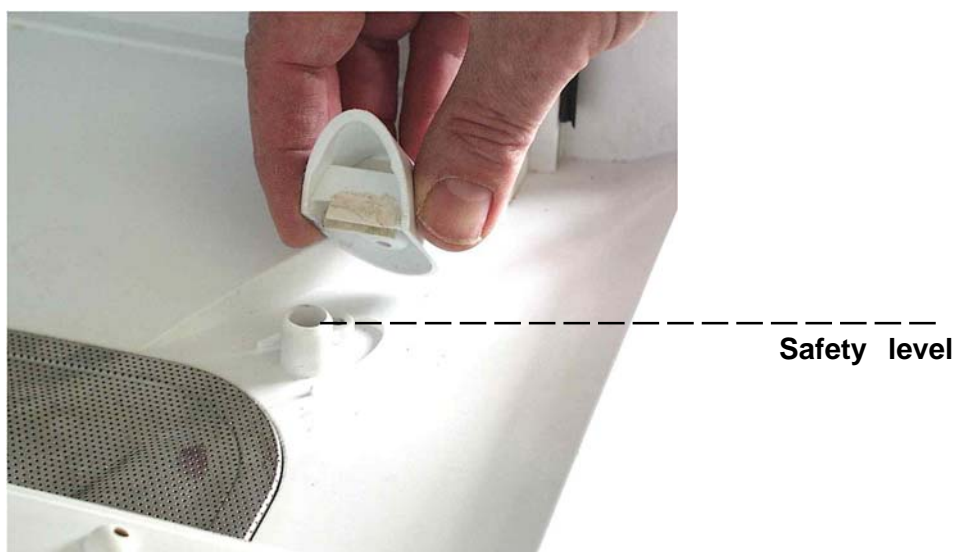

7. Water Inlet

The water flows into the regeneration dosage chamber via inlet valve, over air break, into regeneration dosage chambers and into softener

The level control chamber built into the sump operates the pressure switch.

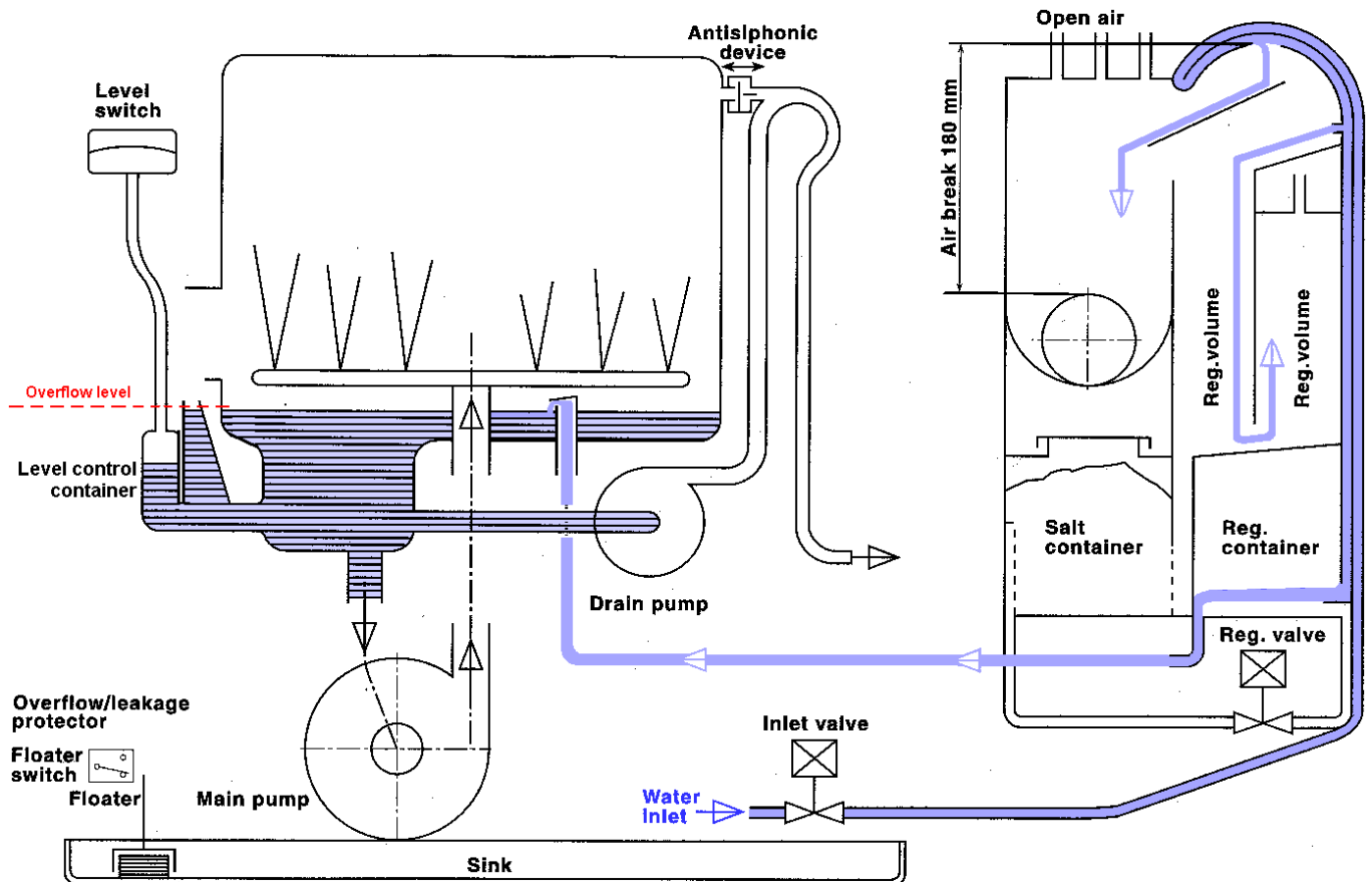

8. Static filling

- Static filling until pressure switch point.
failure code:
If this point isn't reached after max. 2 minutes, a failure code is displayed and the program is stopped.

Power supply interruption during water fill

If the water fill phase is interrupted by opening the door or due to a power failure, the contents of the counters are stored in memory; when the door is re-closed or when the power supply is restored, the water fill resumes from the point at which it was interrupted; the new counter values are added to those previously memorized.

9. Washing

Once the fill phase has been completed, the cycle proceeds to the washing phase. The washing phase is carried out using cold or heated water, and the status of the pressure switch is monitored constantly to ensure that the hydraulic system functions correctly. Water replenishment cycles may be performed if necessary.

If the pressure switch returns to EMPTY during the washing phase, the fill solenoid is energized for a maximum time equivalent to **T.S. x 3** (maximum allowable total fill time).

If this time is exceeded, the washing cycle is completed, but no further supplementary fills are performed. In this situation, alarm condition **[F 0]** is stored in memory. This alarm code is not displayed to the user, but can be accessed by the Service Engineer using a specific procedure.

Washing system

The appliance features the classic washing system in which the mechanical washing action is obtained by the rotation of the washing pump which, by ducting water into the hydraulic circuit, actions the two spray arms simultaneously.

The washing pump is actioned by an asynchronous motor with a start-up capacitor (2,5µF).

The washing pump rotates in a counter-clockwise direction (seen from the impeller side).

Heating

The heating element is enclosed in a protective tube, and is used to heat the washing water (but does not switch on during the drying phase). The heating element is fitted to the outlet of the washing pump and connected to the duct which feeds the upper spray arm.

The heating element is powered by electronic control and by the level pressure switch, which must be set to "FULL" (contact closed on 1-3).

The temperature of the water is controlled by the main circuit board via an NTC sensor.

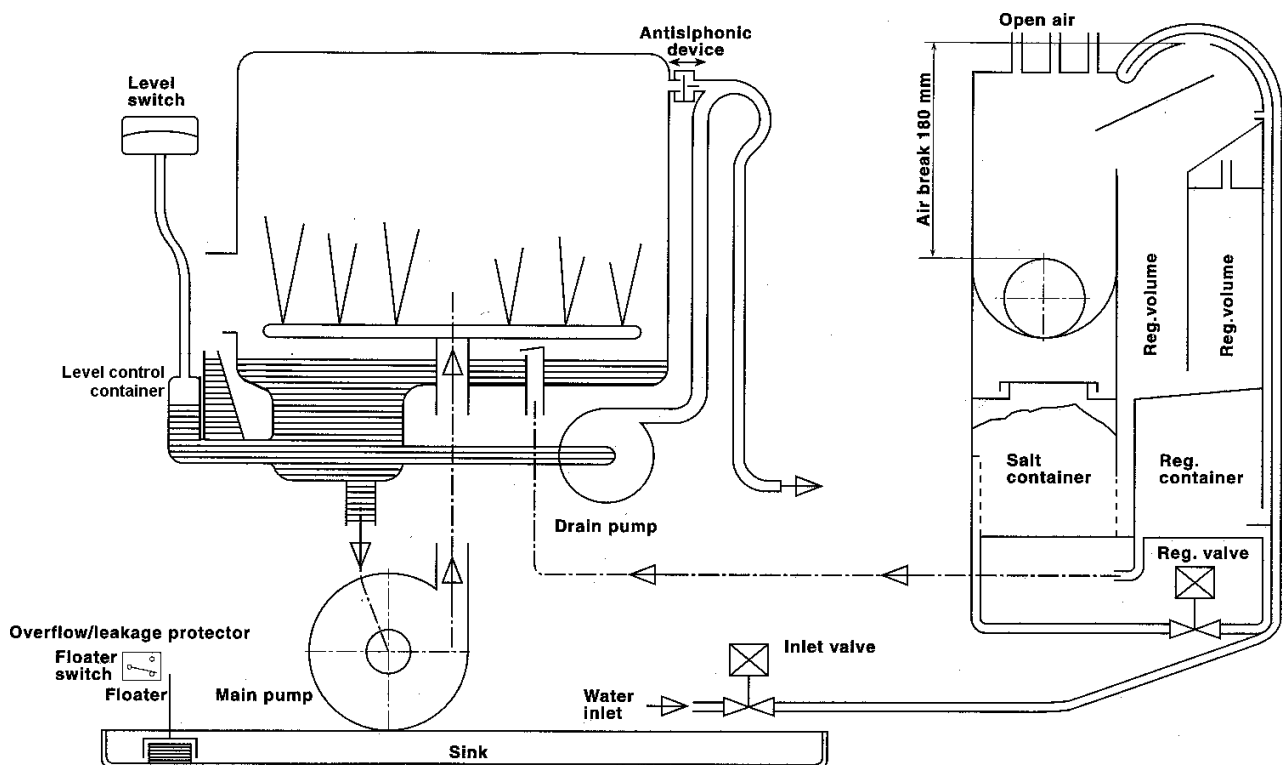

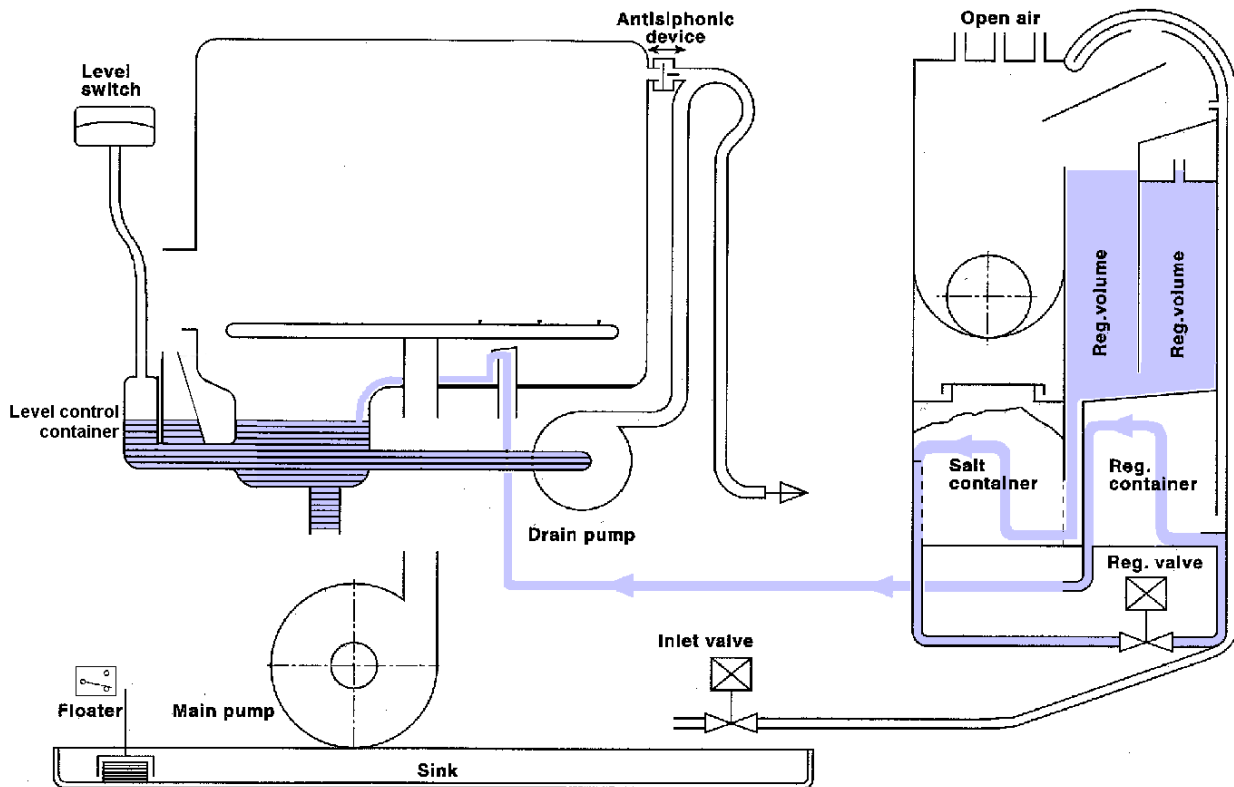

10. Regeneration

The water chamber for regeneration contains 230 ml water. During regeneration, the regeneration valve is energized. The 230 ml water runs into the salt container and mixes with the salt to form a brine solution.

In the top of the salt container there is an opening with a small filter, from here the brine solution enters the softener where the resins are regenerated.

Regeneration of the water softening system, which takes around **4 min**, is usually performed at the start of the drying phase.

Every time regeneration is performed (with activation of regeneration solenoid **4**), the accumulation chamber is completely emptied of its contents (about 230 cc of water). Regeneration is controlled by the electronic control system "Ad Hoc", i.e. not at each washing cycle, but rather at intervals determined by the level of regeneration selected:

- If level **[1]** is selected, regeneration is never performed and the SALT LED (if featured) always remains unlit.
- If level **[10]** is selected, regeneration is performed twice during each cycle; first at the end of the washing phase, and then at the beginning of the drying phase.

The regeneration solenoid is powered on the main board and by the contacts of the door switch. Some models may feature a salt sensor, whose Reed contact is connected to the board. When there is no salt, the contact closes and the relative LED lights up (on display board).

11. Rinse out after regeneration

| | |
|---------------------------|---------|
| pump | 30 sec |
| 1. fill & pump | 8 sec. |
| pump | 15 sec. |
| 2. fill & pump (wh 1 + 2) | 8 sec. |
| pump | 15 sec. |
| 3. fill & pump | 8 sec. |
| pump | 30 sec. |

Recycling takes place after the rinsing process, as the final step. Rinsing out then follows automatically with the start of the next wash program.

The pumping off stage usually takes about 50 seconds.

12. Antisiphonic device

If the end of the take-off hose is below the level of the water in the wash space, a siphon effect is possible, that is, the machine runs empty. This is avoided by the ventilation through the anti-siphon valve.

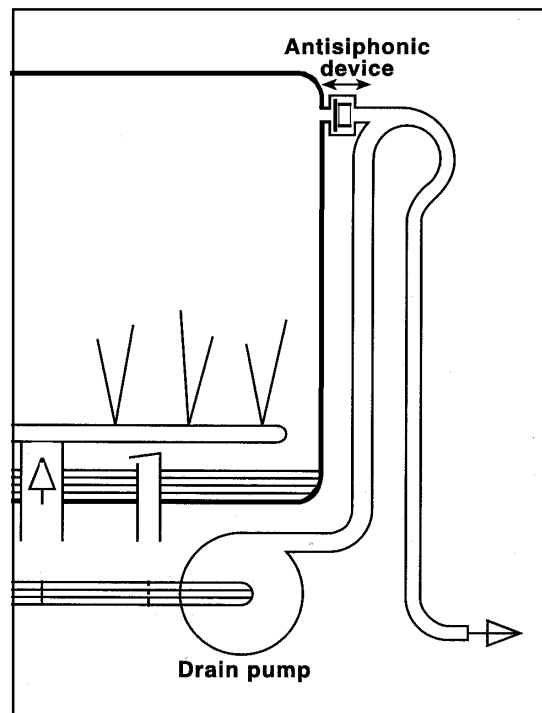

13. Drain

At the end of the drain phase, a control procedure is performed to check that the contact of the level pressure switch is open on EMPTY. If this is the case, the appliance proceeds to the subsequent phase.

If, as a result of a problem in the drain phase, the pressure switch contact remains closed on FULL (i.e. if there is water in the hydraulic circuit), the drain phase is repeated.

On completion of this second drain phase, the status of the pressure switch is again checked. If it is still closed on FULL, alarm [i20] is generated (failure to drain). The time-out for each of these two phases is 120 seconds.

N.B. The washing programmes always begin with a drain phase.

14. In- and Output elements

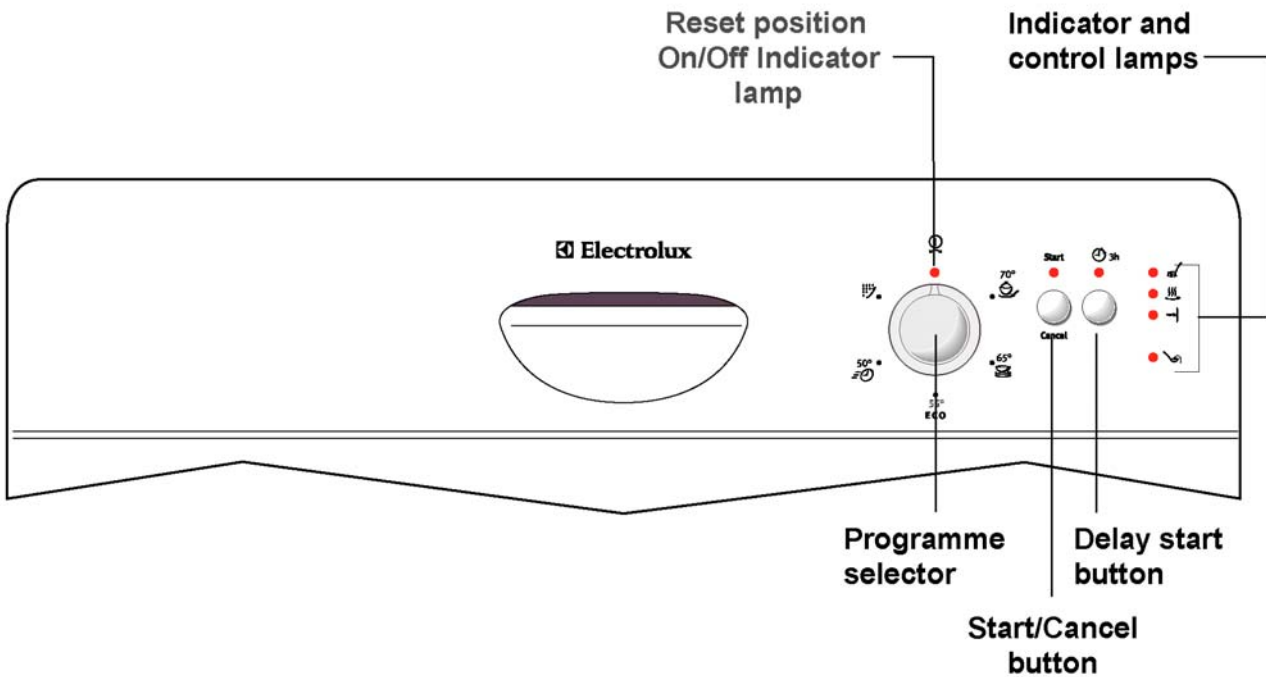

Programme selector



Turn the programme selector clockwise or anticlockwise to select the programme and temperature according to the programme chart.

Start button

In addition to start a programme, you can press this button to adjust the setting of the water softener and cancelling a dishwashing cycle.

Indicator lamps:

Shows current phase of the selected programme.

- Wash cycle in progress  top lamp
- Drying in progress  middle lamp
- Programme cycle ended  lowest lamp

Control lamp:

Shows that refilling of salt container is necessary

15. SERVICE MODE

With this procedure it is possible to access the Service Diagnostics System. Once this mode is accessed, it is possible to:

- read and cancel the alarms
- control the operation of the various components of the appliance
- start the Service diagnostics mode

Reading the alarms and activating the individual components

To activate the function:

- 1) Press and hold down the button **S1**.
- 2) Turn the knob anti-clockwise till **Position 5**:
 - The LEDs LD0 and LD1 flash.
 - Release button **S1**.
 - Press button **S1**.
 - the first memorised alarm is displayed: the **End of cycle** LED flashes and pauses: for the decodification, please refer to table of alarm codes.
- 4) Press again button **S1** to display the second alarm.
- 5) Pressing button **S1** again, the third alarm is displayed.
- 6) Pressing button **S1** for the fourth time, the appliance actuators are activated:
 - 4th actuation: regeneration solenoid
 - 5th actuation: drain pump
 - 6th actuation: water fill solenoid and washing pump (water up to level)
 - 7th actuation: heating (only if water up to level)
 - 8th actuation: washing pump
 - 9th actuation: detergent/rinse-aid dispenser
 - 10th actuation:
 - 11th actuation: it starts again from the first alarm

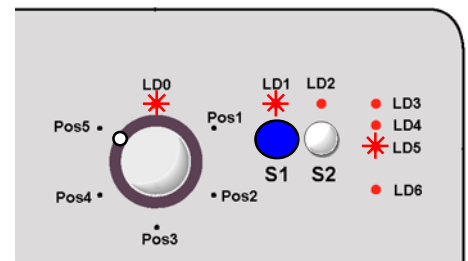
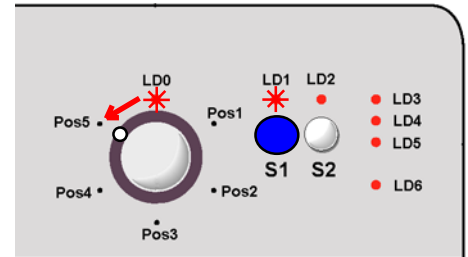

All positions can be repeated pushing button S1 sequentially.

The components are powered with door closed.

If button S1 is not pressed for 60 seconds, the diagnostics terminate automatically.

Cancelling alarm codes from memory / test of LEDs

It is good practise to cancel the alarm memorised:

- after reading the alarm code, to check whether it is repeated during the diagnostics test.
- after repairing the appliance, to check whether it is repeated during the testing cycle.

To activate the function:

- 1) Press and hold down button **S1**.
- 2) Turn the knob anti-clockwise till **Position 5**:
 - the LEDs LD0 and LD1 flash.
 - release button **S1**.
- 3) Turn the knob till **Position 4**.
 - press button S1.
 - all LEDs start to flash for 30 seconds.

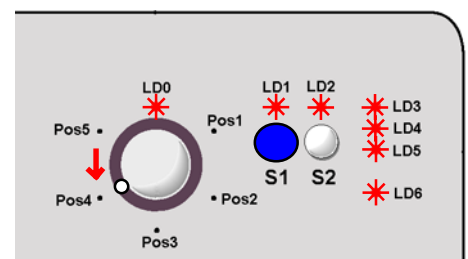
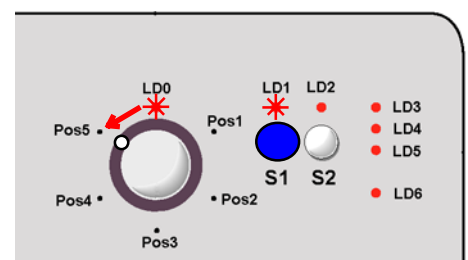

Functional testing cycle

This is an abbreviated washing programme (50 min) which allows the Service Engineer to test all the functions that comprise a traditional washing cycle; in effect, the system simulates a normal cycle.

Selecting the cycle

To activate the function:

1. Press and hold down button **S1**.
2. Turn the knob anti-clockwise till **Position 5**.
 - the LEDs LD0 and LD1 flash.
 - release button **S1**.
3. Turn the knob till **Position 3**
 - press button **S1**.
 - the programme starts: the programme behaves as in a normal cycle; the PAUSE and CANCEL options are accessible.

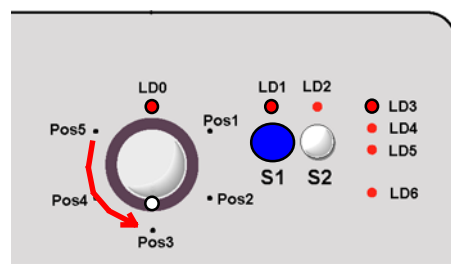
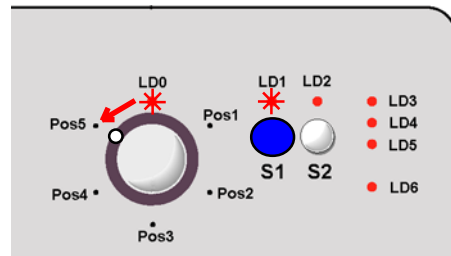

Exiting Service and User modes

To exit these modes, turn the knob to OFF position and switch the appliance off or wait **60 seconds**: the LEDs light up and the appliance returns to selection mode.

16. Alarms

When an abnormal situation occurs that may interfere with machine functioning, the main board activates a safety system which in most cases interrupts the washing cycle. The last three alarm situations are stored in memory. Using a special procedure, service personnel can display all the alarms stored in memory. The user is only shown four of the alarms in progress.

The END OF CYCLE LED flashes repeatedly.

| Type of Alarm | No. flashes of end-of-cycle LED | Displayed to the user | Description of the alarm condition | Machine status | Possible causes |
|---------------|---------------------------------|-----------------------|---|--|--|
| i10 | 1 | yes | Water fill time-out (The pressure switch does not close on FULL after 90 sec. static fill, or never closes on "FULL" during the initial 60 sec of the dynamic fill at 2800 rpm) | The drain pump switches on, then the cycle stops | Tap closed; water mains pressure too low; fill solenoid / wiring faulty; hydraulic circuit of pressure switch obstructed; level pressure switch / wiring faulty; circuit board faulty |
| i20 | 2 | yes | Water drain time-out (The pressure switch does not return to EMPTY after two drain phases lasting 120 seconds) | The drain pump switches on, then the cycle stops | Drain circuit obstructed/blocked; drain pump interrupted or jammed (foreign bodies); level pressure switch blocked on FULL (1-3); hydraulic circuit of pressure switch obstructed; wiring faulty; circuit board faulty |
| i30 | 3 | yes | Intervention of Anti-flooding system (the drain pump switches on) | The cycle is interrupted and the drain pump switches on | Water leakage from the tub - sump and various connections (pump, upper spray arm duct etc.). Floating sensor blocked mechanically. Microswitch faulty. Fill solenoid blocked mechanically. Circuit board faulty (solenoid triac short-circuited) |
| i50 | 5 | yes | Motor triac short-circuited (the washing pump runs uncontrolled at maximum speed) | Water fill to level (if necessary), deactivation of the other actuators, cycle interrupted. The washing motor runs at maximum speed and the alarm is displayed. | Circuit board faulty |
| i60 | 6 | no | Heating Time-out (the check takes place every 3 minutes: the temperature must increase by a certain amount at each step) | The programme continues to the end without heating (the washing result will probably be unsatisfactory) | Heating element faulty; intervention of safety thermostats (open); wiring faulty; NTC sensor (poor thermal contact); insufficient water circulating in the tub; washing pump faulty (impeller stripped); circuit board faulty. |
| i70 | 7 | no | NTC sensor short-circuited or open | The programme continues to the end without heating (the washing result will probably be unsatisfactory) | NTC sensor faulty; wiring short-circuited / open; circuit board faulty. |
| i80 | 8 | no | Communication error between the microprocessor and the EEPROM | Machine inoperative: no selection possible (*) | Circuit board faulty. |
| i90 | 9 | no | Problems with software configuration | The fault occurs when switching on: no selection possible (*) | Circuit board faulty (configuration software incorrect). |
| ib0 | 11 | no | Problems with the turbidity meter [if featured] (Calibration Time-out) | The programme continues as if a "heavy soiling" condition had been detected. | Turbidity sensor faulty; sensor wiring faulty; circuit board faulty. |
| id0 | 13 | no | Problems with the washing motor: no signal from the tachometric generator (washing pump powered, but no signal from the generator) | The heating element is switched off. If the fault persists after the Time-out, the washing pump operates at maximum speed and the alarm code is stored in memory (the cycle continues) | Motor winding interrupted / short-circuited; motor jammed (foreign bodies); wiring to washing motor faulty; motor capacitor faulty; Tachometric generator interrupted / short-circuited; circuit board faulty. |
| iF0 | 15 | no | Water replenishment Time-out (3 times during the T.S. Time-out) | The cycle continues until the next phase without supplementary fills and without heating. The error is cancelled on completion of a drain phase. | Dishes upside-down; central filter clogged; excessive foam; leaks from the sump-pressure switch coupling; pressure switch faulty / false contacts. |

Service tips

You need
screwdriver
Torx TX20



Replacement of the components within the door.

Remove the screws from the frame.

Carefully unclip the front of the door.

Before finally opening, unclip the on/off LED.

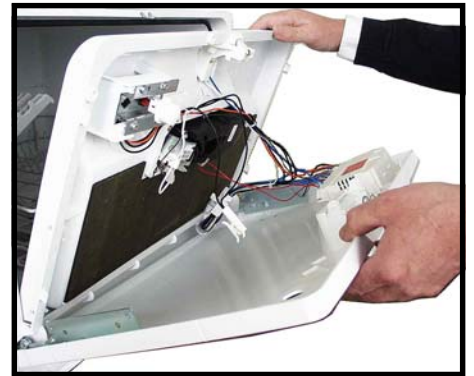

The electronics can then be snapped out.

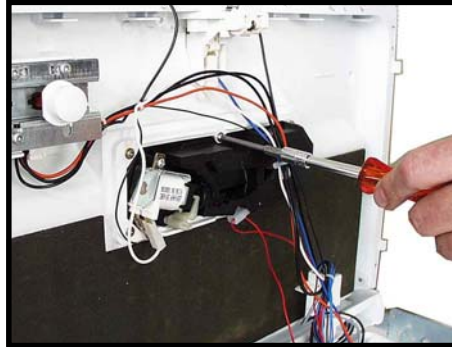

The dosing unit is held by screws.



After removing these screws, the components can be removed from the door breach.



After removing the spring, the door-opener can be removed from its hinges.

Re-assembly is carried out in the reverse order.



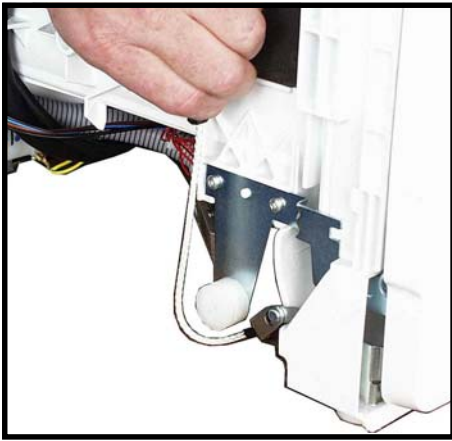

Replacement of the door hinge.

After slackening, the door spring is removed from its hinges together with the deflection band.

After removing the screws on the chassis and on the door-frame, the door hinge can be removed.

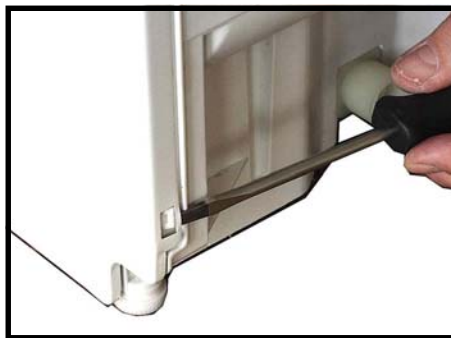

Housing

After removing the housing screws (lay the machine on its side) from the bottom of the machine, the housing is unclipped front and back from the catches and can be removed.



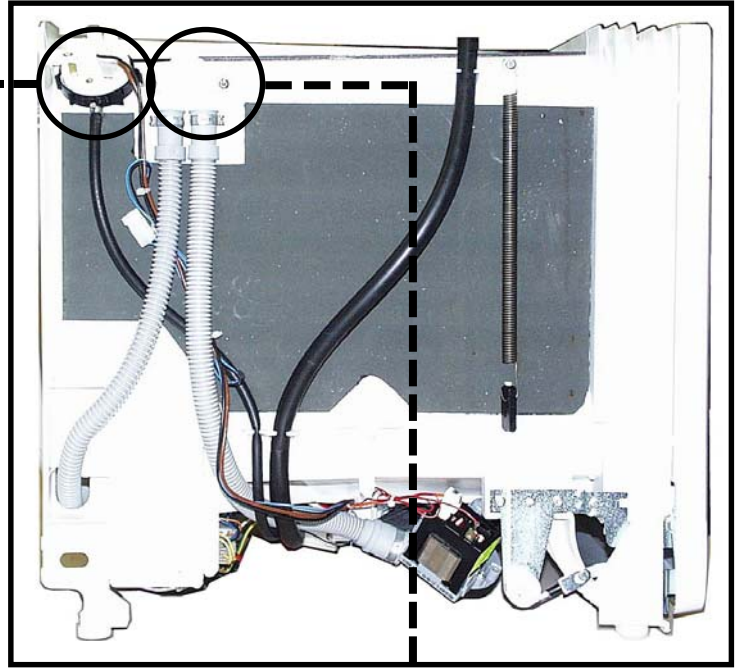

The **pressure monitor** is simply unscrewed.

The take-off hose ventilation can be unscrewed for cleaning when necessary, in case these rubber parts in the interior of this valve become dirty or stuck because of residues.



The air should be able to enter the hose from the holder - not the other way around!



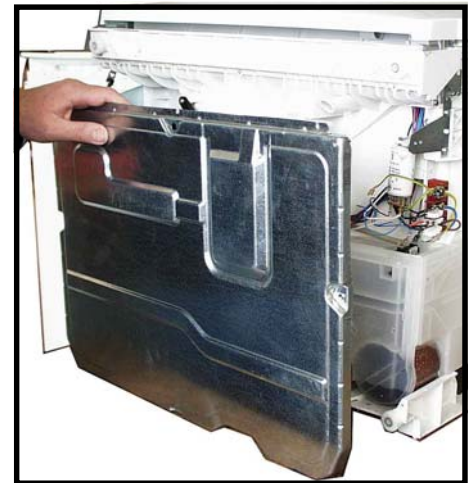
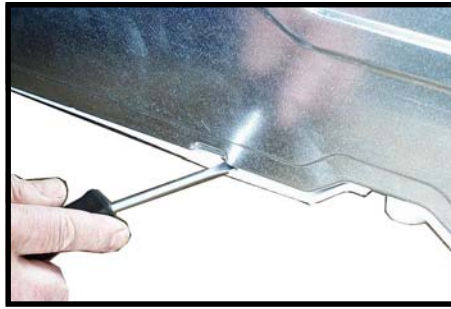

The floor of the machine is held with screws at the front, and clipped in at the back.

It contains the bosses for the overflow water and the flooding switch.

After removal you come to the most important functional components.

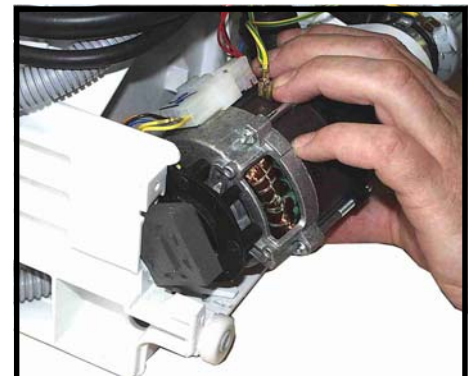
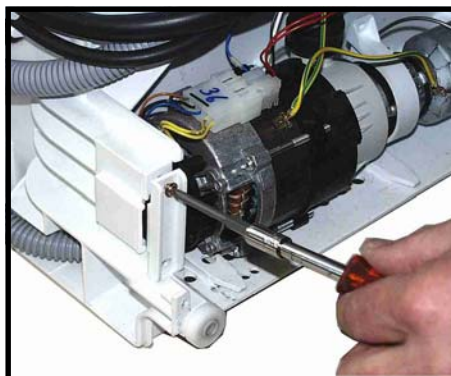
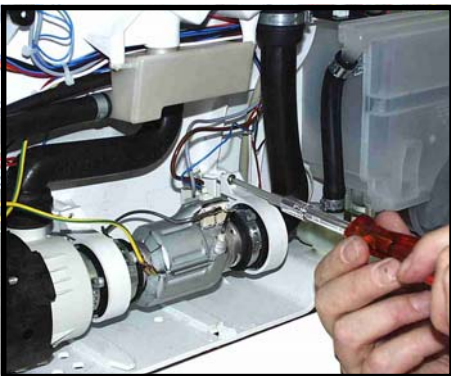
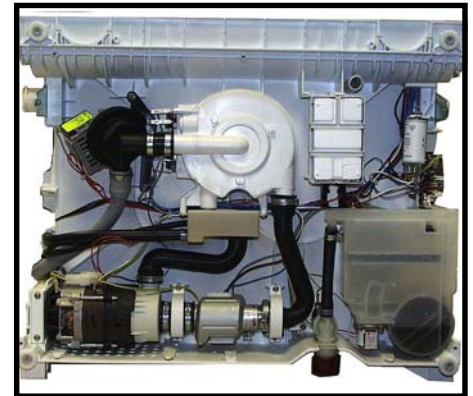

After loosening the screws of the two holders and the yoke, the tumble pump/continuous flow heater unit can be taken out.

The bayonet breech of the pump chamber can be simply released, for possible cleaning.

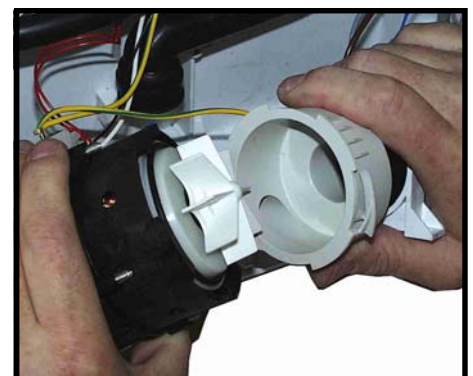
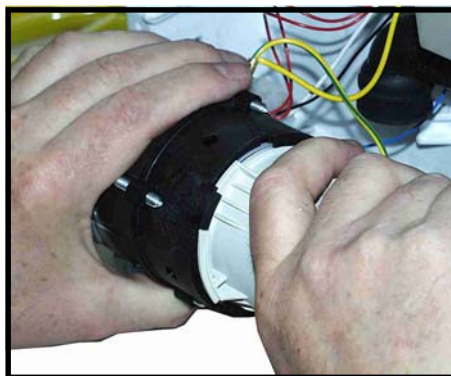

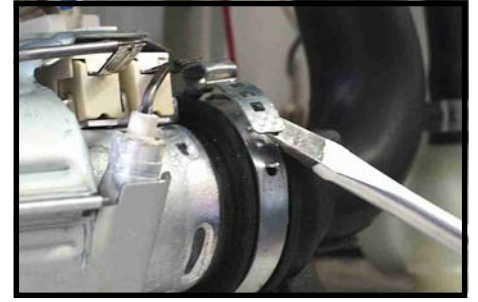
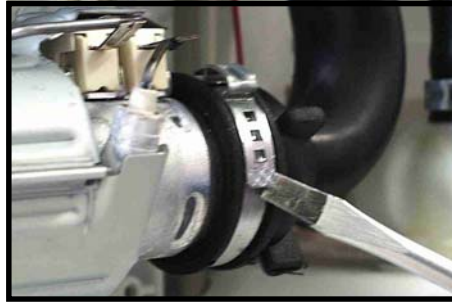

To release the hose clamps, it is recommended that this assembly be taken off its hinges.

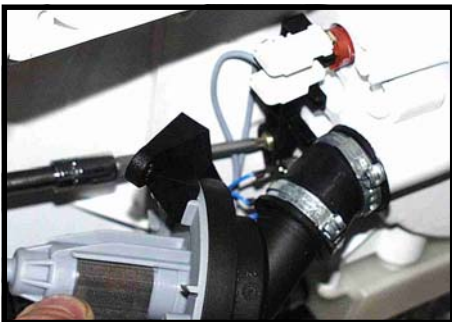

The mounting for the thermostats is screwed in behind the leach pump.

After its release, the thermostats can be removed.

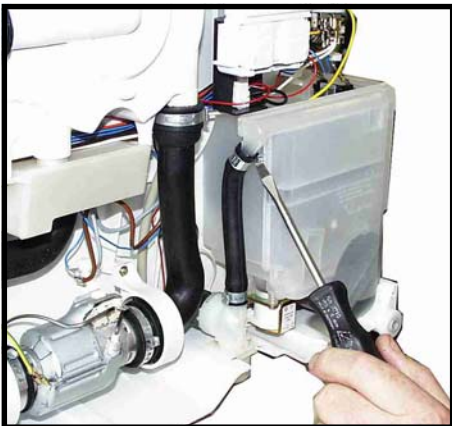

After the removal of the hose, the valve can be drawn out of the chassis with suitable pliers.

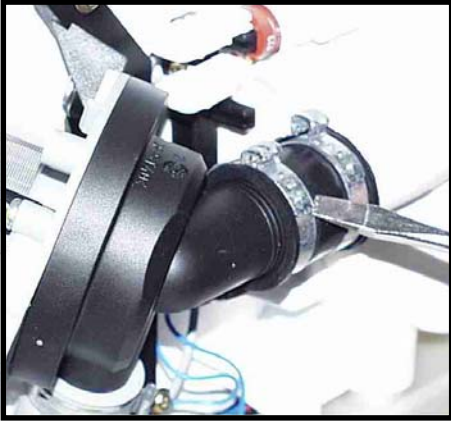

To dismount the leach pump, the hose clamps are released and the screws removed.



Here you can see how the hose clamps can be re-tensioned with wire cutting pliers.

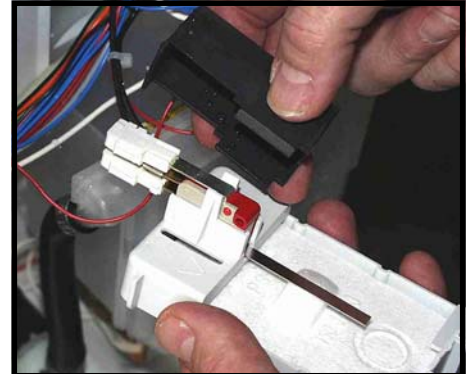
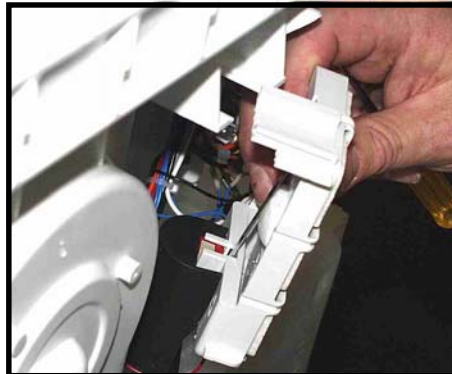

The flooding switch is snapped out with a small screwdriver and can be taken out of its mounting.

After removing the protective cap, the microswitch can be snapped out.

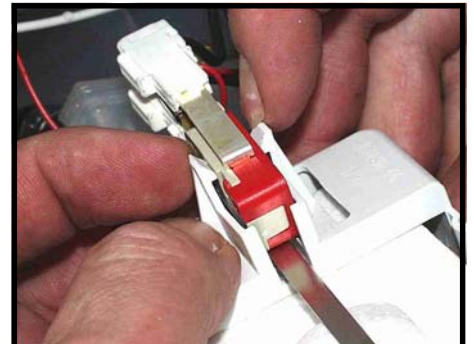

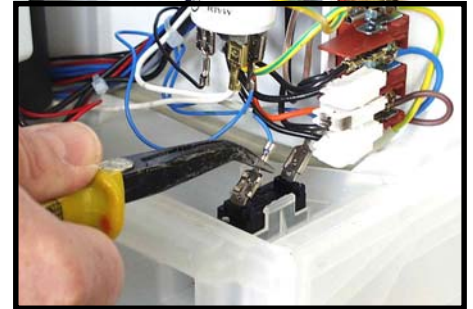
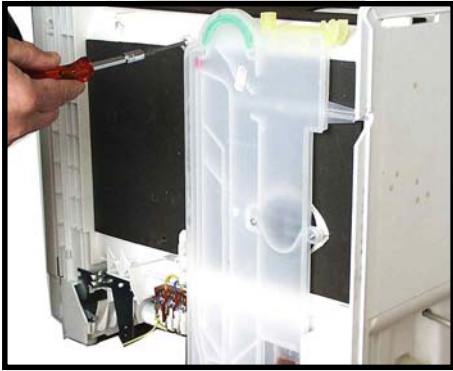

To dismount the water softener, these attachment screws are removed.

The connections on the reed switch are removed.

The hose connections are detached.



The large nut of the salt holder can be released with the help of a V-belt. A spanner is useful in removing the recycling inlet nut.



Now the complete unit can be removed.

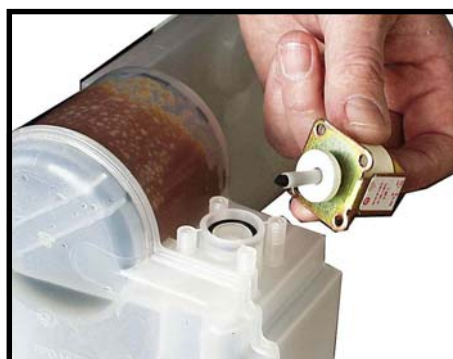

After undoing the screws of the recycling valve, this can be removed.

18.2. Wiring

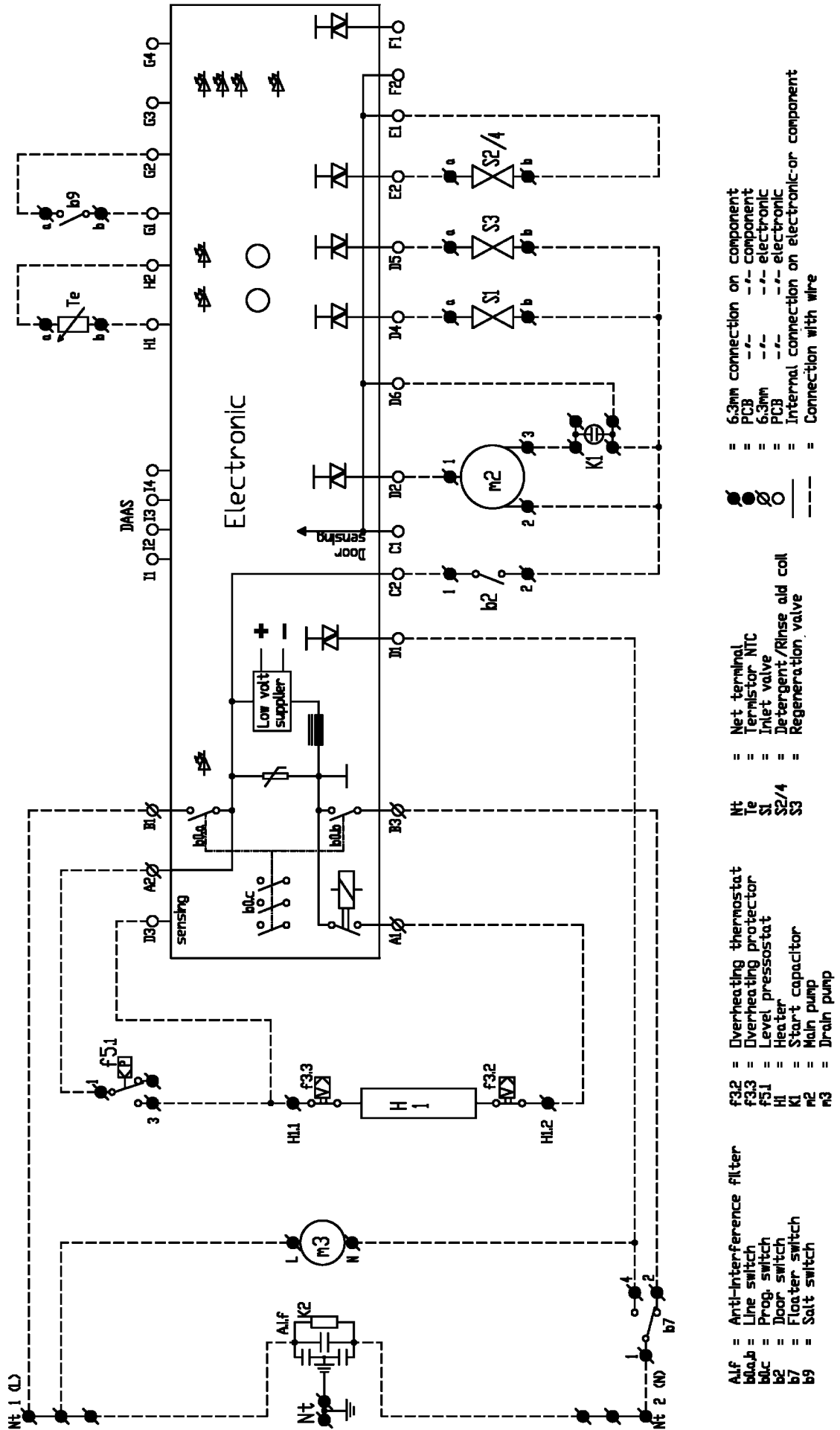

19. Measuring points and values

Conditions:

- Door closed
- Main plug disconnected
- Main switch ON
- Electronic plugs disconnected

