

## SERVICE- INSTRUCTION

### AES II- Absorption Refrigerators

(only for built- in in motor caravan)

RM 4185  
RM 4215  
RM 4235  
RM 4265  
RM 4275  
RM 4285  
RM 4365  
RM 4405  
RM 4505  
RM 4605  
RM 4705  
RM 4805  
RM 5215  
RM 5275  
RM 5405  
RM 6275  
RM 6295  
RM 6405

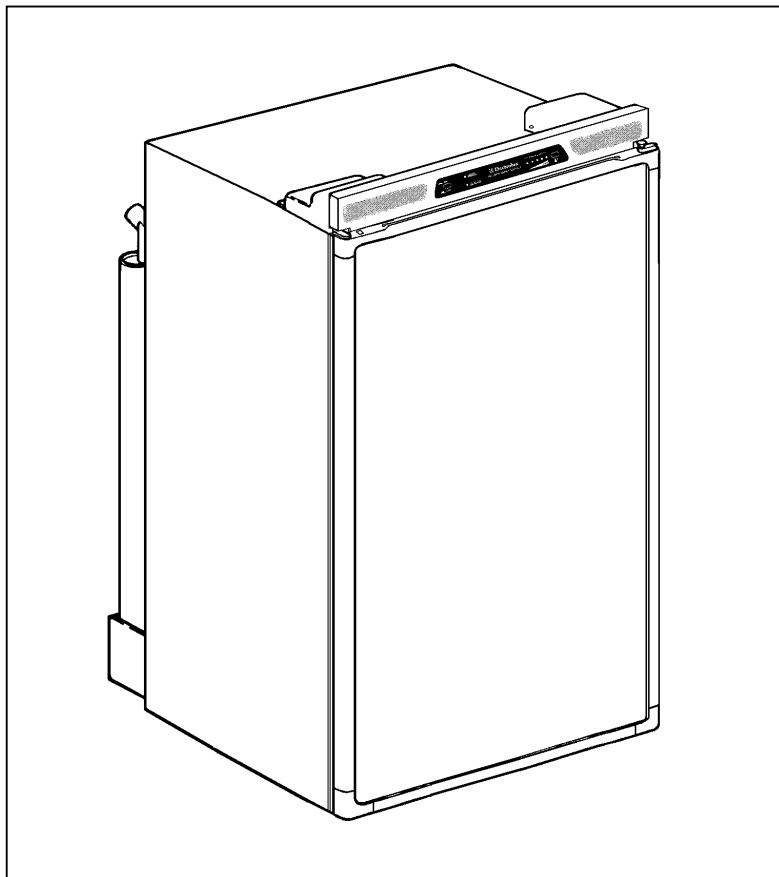

Language: English

Publications-No.:  
599 47 22-58/4

replaces 599 47 11-18/1



T.D. RS 12/99

<b>Table of Contents</b>	<b>Page</b>
<b>1.0 Model Description</b>	<b>3</b>
<b>2.0 AES II System Function</b>	<b>3</b>
2.1 <b>Priorities</b>	<b>3</b>
2.2 <b>Switchover Times / Time Delays</b>	<b>3</b>
2.3 <b>Low Voltage Operation</b>	<b>4</b>
2.4 <b>Tank Stop</b>	<b>4</b>
2.5 <b>Thermostat Sensor</b>	<b>4</b>
<b>3.0 Technical Descriptions</b>	<b>5</b>
3.1 <b>Block Diagram</b>	<b>5</b>
3.2 <b>Power Module Connections</b>	<b>6</b>
3.3 <b>Display Module</b>	<b>7</b>
3.4 <b>Power Module</b>	<b>8</b>
3.5 <b>Ignition Device</b>	<b>8</b>
3.6 <b>Thermocurrent Adapter</b>	<b>8</b>
<b>4.0 Installation</b>	<b>8</b>
<b>5.0 Troubleshooting</b>	<b>8</b>
5.1 <b>Diagnostics Mode</b>	<b>8</b>
5.2 <b>Error Analysis and Elimination</b>	<b>9</b>
<b>6.0 Wiring Diagram</b>	<b>11</b>
<b>7.0 Spare Parts Numbers</b>	<b>12</b>
<b>8.0 Service Bulletins</b>	<b>13</b>
<b>9.0 Operation of AESII with solar charging regulators</b>	<b>17</b>

# 1.0 Model Description

I.E.

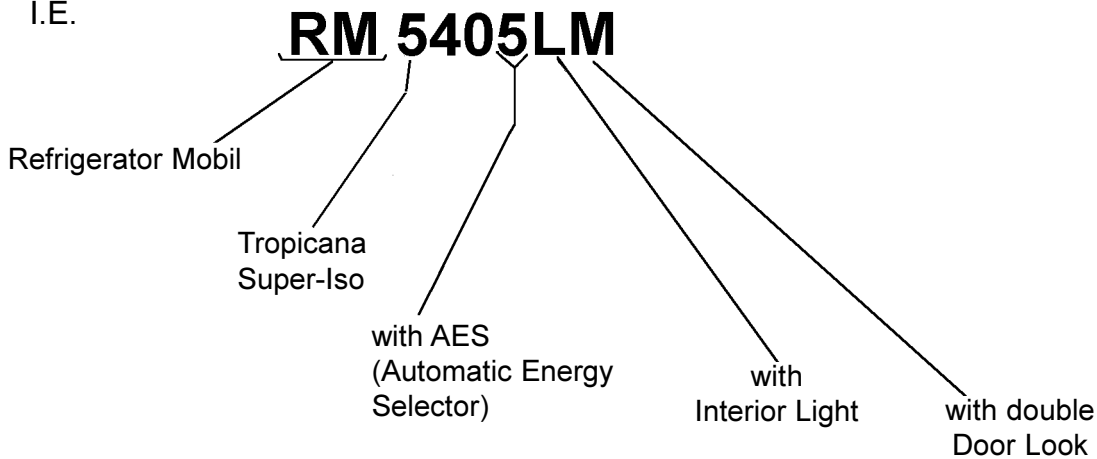

## 2.0 AES II System Function

An **AES II** refrigerator **independently** selects between the possible energy sources of **230 V, 12 V, and gas**. The control electronics automatically ensure that the refrigerator is supplied from the energy source optimal at a given time. You **can not operate the refrigerator with more than one energy source simultaneously**. You may also not manually select a certain energy source. The electronic thermostat controls the refrigerator during "ON/OFF" operation, independently of the energy source.

**The basic function for the AES II is: cooling under all conditions.** The amount of voltage applied each time is therefore monitored during electrical operation (230 V or 12 V). If the voltage falls below the relevant limit values (200 V for mains power supply voltage and 11 V for battery operation), gas operation is selected (see **low voltage operation**). **For its operation, the AES II refrigerator requires a 12 V continuous plus supply to operate the control electronics.**



Operation on a 24-V power supply is not possible.

### 2.1 Priorities

The refrigerators selects the type of energy according to the following priorities:

- 1) **230V:** if the voltage > 200 V
- 2) **12V:** if the motor is running (D+ signal from the generator) and voltage > 11V
- 3) **Gas:** if 230V is not present or < 200V, or 12V voltage < 11 V

### 2.2. Switchover Times / Time Delays

The following diagram displays the switchover times between the individual energy sources:

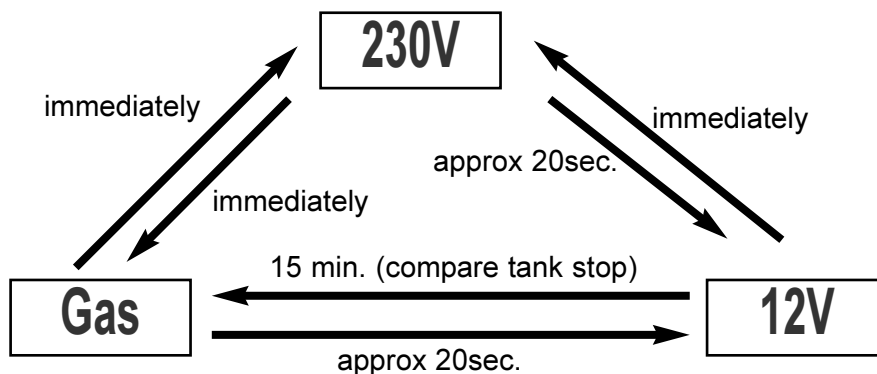

## 2.3 Low Voltage Operation

The so-called "low voltage gas operation" is an exception. If the electrical power supply voltage in 230-V or 12-V operation is insufficient to maintain the cooling operation, the AES switches to gas operation under certain conditions. A yellow LED displays this state. The conditions for switching over to gas operation are described in Section 2.2. If gas operation is selected due to low voltage, the refrigerator remains in gas operation for 30 minutes to avoid a continuous switching back and forth (oscillation) between the energy sources. After 30 minutes of gas operation, the electronics checks the applied voltage at regular intervals. If the power supply voltage again becomes sufficient, the refrigerator again switches to 230-V or 12-V operation.

## 2.4 Tank Stop

The AES electronics does not begin operating the refrigerator on gas until the motor has been turned off for 15 minutes to avoid an undesired switchover to gas operation during a tanking procedure.

## 2.5 Thermostat Sensor

The thermostat sensor consists of an electrical resistor (NTC). The resistor is installed on the evaporator cover, but it does not have a direct connection to the evaporator coil. The purpose is to measure the air temperatures on the inside of the refrigerator. This is how the electronics always controls the refrigerator at the temperature that has been set once, even for changing ambient temperatures within the framework of the unit's capacity.

**Important::** The sensor must not come into direct contact with the aluminum evaporator (space sensor is not an evaporator sensor) to provide correct functioning.

**The device goes into continuous operation if the thermostat sensor is defective.**

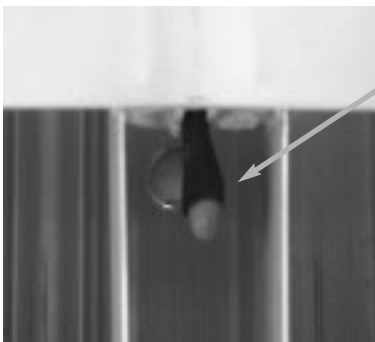

Thermostat Sensor

Reference value of the sensor:

Room temperature in °C	Resistance (kOhm)
5°	ca. 7,24
10°	ca. 5,63
15°	ca. 4,42
20°	ca. 3,50

# 3.0 Technical Descriptions

## 3.1 Block Diagram

The following diagram shows the AES II system components:

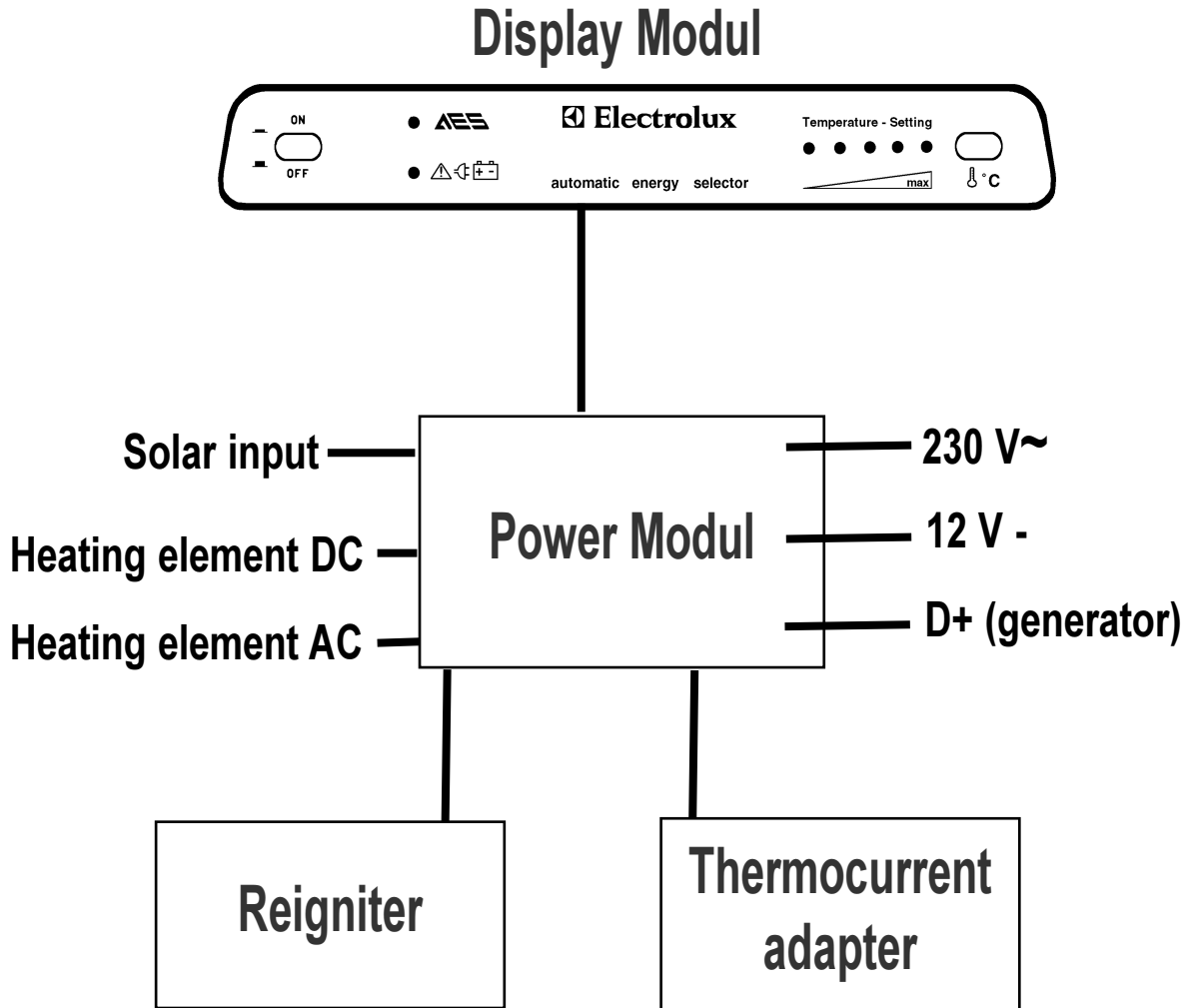

## 3.2 Power Module Connections

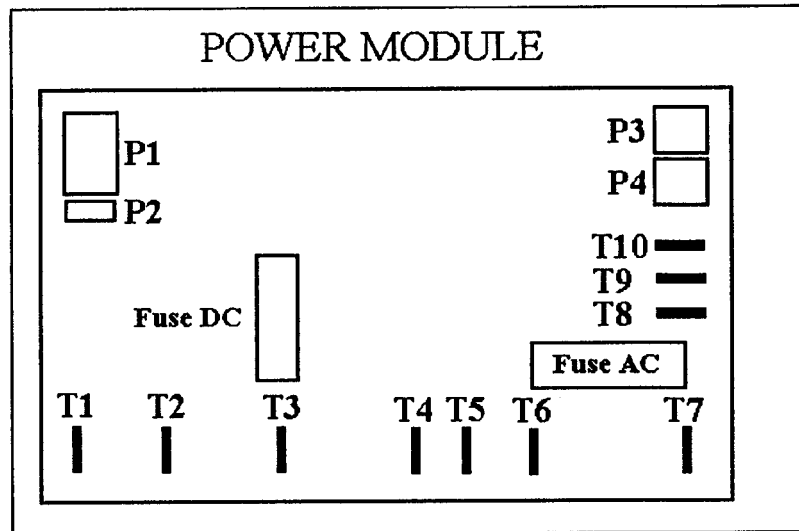

<u>Connection</u>	<u>Type</u>	<u>Definition</u>
P1	I / O	Connection cable display/ power module
P2	I	Temperature sensor
P3	I / O	Reigniter
P4	O	Lifting magnet
T1	O	12V DC lighting
T2	O	12V DC heating element
T3	I	12V DC power supply (+)
T4	I	230V AC
T5	O	230V AC heating element
T6	O	230V AC heating element
T7	I	230V AC
T8	I	Ground
T9	I	Generator (D+)
T10	I	Solar system

### 3.3 Display Module

The display module is located on the control frontplate of the AES II refrigerator.

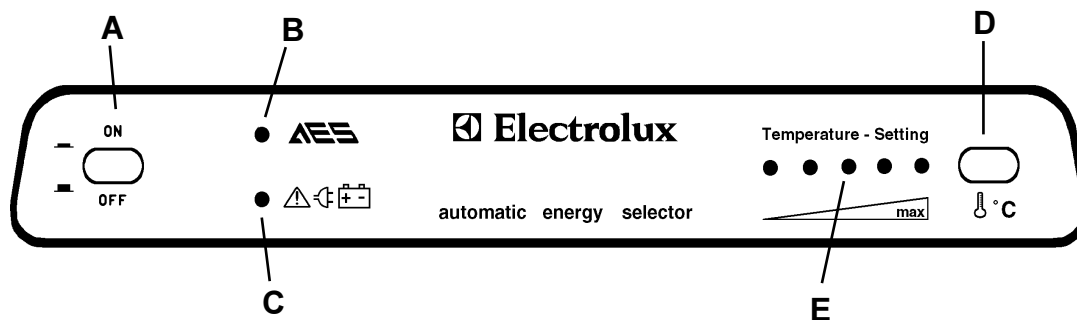

- |   |  |                        |   |
|---|--|------------------------|---|
| A | Power switch   |                        |   |
| B | AES operation indicator                              | GREEN:<br>flashing RED | Refrigerator working<br>Fault in the gas operation,<br>refrigerator not cooling.                  |
| C | Low voltage LED                                      | YELLOW                 | Refrigerator in gas operation,<br>because the electrical power supply<br>voltage is insufficient. |
| D | Sensor for temperature setting                       |                        |   |
| E | LEDs for displaying the selected temperature setting |                        |   |

You must operate the power switch (A) to turn the device on.

The AES function LED (B) then lights up green, and the middle LED (E) lights up yellow to display the selected temperature setting.

You can use the momentary-contact pushbutton for temperature selection (D) to change the refrigerator section temperature setting. The low voltage LED (C) lights up yellow if the refrigerator has selected gas operation to maintain the refrigerating capacity due to low voltage in an electrical supply source (230 V or 12 V).

If there is a fault during gas operation (gas couldn't be lit, gas container empty, etc.), the AES LED (B) flashes red. In this case, the device does not continue to cool. You must eliminate the gas fault and start the refrigerator again. (Use the power switch to switch the refrigerator off and on again.)

**Important::** If there is a fault during gas operation and you don't notice it before the refrigerator changes to 230 V, for example, due to a priority change, the AES LED (B) again changes to green until the cooling function has been established again. However, the next time it wants to change to gas operation, the fault is displayed again, and gas operation is not started. The reason is that there are legal regulations that do not permit the device to carry out an automatic reset. If you have a gas fault displayed by a red flashing AES LED (B), you absolutely must acknowledge this gas fault by using the power switch to switch the device off and on again.

## 3.4 Power Module

The power module (A) is located on the backside of the refrigerator. A multicore cable connects the power module and the display module.

**There are fuses to protect both electrical heating cartridges located in the power module.** All the electrical components for controlling the various operating modes are located in this module. The module's printed circuit board has been sealed completely water tight to protect against environmental influences.

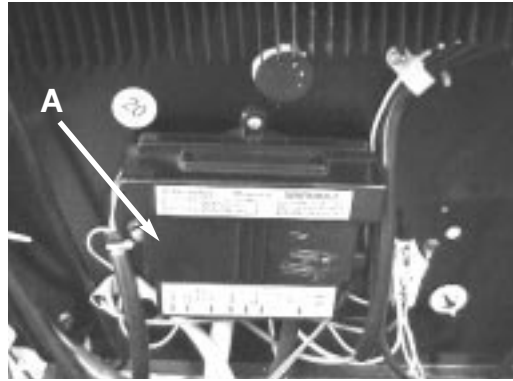

## 3.5 Reigniter

The reigniter is also located on the backside of the refrigerator. The power module supplies the reigniter<sup>3</sup> with voltage. Refer to Publication Bulletin Number 599 4716-54/5 (Pages 13-14) for detailed information about the ignition devices used.

## 3.6 Thermocurrent Adapter

The thermocurrent adapter is located between the ignition fuse and the thermoelement coupling. The power module controls the thermocurrent adapter. The adapter serves to switch off gas operation during the change from gas to another operating mode by interrupting the thermocurrent to the ignition fuse.

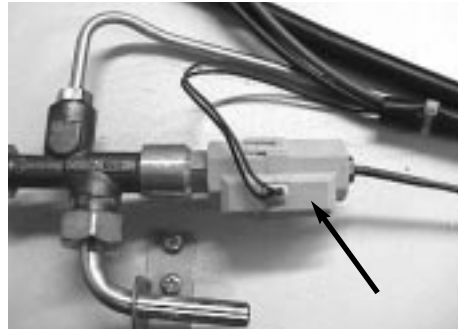

## 4.0 Installation

To guarantee the orderly functioning of the AES II refrigerator, correct electrical installation is absolutely necessary.

The 12-V connection to the battery must be a 2-pole connection.

The connection cable must be 6 mm<sup>2</sup> and be 10 mm<sup>2</sup> for greater lengths.

The D+ control input must be wired from the generator to the 12-V supply terminal (cable cross-section 1 or 1.5 mm<sup>2</sup>, otherwise 12-V operation is not possible).

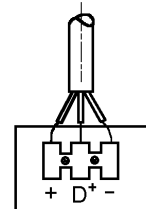

## 5.0 Troubleshooting

### 5.1 Diagnostics Mode

The AES II system has a built-in diagnostics program used to test basic system functions.

The test program offers the capability to switch the refrigerator deliberately into certain operating states.

The following test sequences are available:

- Self-test for the display module and power module and for communication between both components
- AC operation (230 V) test
- DC operation (12 V) test
- Ignition device test



### a) Preparations

The AES II device must be connected to a 230-V supply line and a 12-V supply. You must connect a gas cylinder and open the gas supply to test the gas function.

### b) Test execution

You must proceed as follows to arrive at diagnostics operation:

1. Switch off the device
2. Press the button for the temperature setting and keep this button depressed. Use the power switch to switch the device on.
3. Keep the button for the temperature setting depressed until the AES operation LED switches to red and diagnostics operation begins.

**The AES operation LED is red during diagnostics operation.**

A self-test for both electronic modules is first carried out, and all the display module LEDs are controlled once. The left temperature LED then lights up. Diagnostics operation has selected the original position.

You can select the following tests when you activate the temperature selection switch:

- LED 1: All outputs are switched off, standby mode
- LED 2: Mains power supply, 230-V heating cartridge is controlled
- LED 3: Lifting magnet, thermocurrent adapter, and the ignition device\* are controlled
- LED 4: 12-V operation, 12-V heating cartridge is controlled
- LED 5: Ignition device is controlled

\* **Important:** For safety reasons, it is possible to control the lifting magnet just once. If the lifting magnet is controlled again, you must first switch the device off and then start diagnostics operation again.

### c) Terminating diagnostics operation

You can use the power switch at any time to switch the device off and terminate diagnostics operation. If someone unintentionally forgets to switch off the diagnostics operation, the device switches back to cooling operation after four minutes.

## 5.2 Error Analysis and Elimination

### 1. Gas Operation

Errors according to priority:

**Error:** Fault LED flashes red

**Cause 1:** The lifting magnet does not remain tightened for the required 20 seconds. The thermoelectric voltage is insufficient, and the ignition fuse closes.

**Elimination 1:** Exchange the electronic.

**Cause 2:** The spark plug fires even though there is a flame present (no flame recognition). The electronics switch to fault after 25 seconds.

a) The connection between the spark plug and ignition cable is deficient. (Refer to Bulletin 599 4717-69/1, Page 15.)

b) The ignition device is defective. (See Bulletin 599 4716-54/5, Pages 13-14.)

**Eliminaion 2:** Change the spark plug or the reigniter.

**Cause 3:** After the lifting magnet drops, the AES again tries to ignite and then goes to a fault after 25 seconds. Is the thermoelement on the thermocurrent adapter loose?

**Elimination 3:** Hand-tighten the screw connection (SW 8mm).

**Cause 4:** The thermoelectric voltage is not sufficient to keep the ignition fuse open. The reason is due to wear and tear and component tolerances, for example:

1. Bad thermoelement (soot formation)
2. The thermocurrent adapter's internal resistance is too high.
3. The holding current for the magnetic insert for the ignition fuse is too much.

**Elimination 4:** Exchange the thermocurrent adapter and the ignition fuse and/or thermoelement. (See Bulletin 599 4721-91/7, Page 16.)

**Cause 5:** The lifting magnet does not press the ignition fuse down deeply enough, so there is no mechanical contact in the magnetic insert

**Elimination 5:** To check after tightening the lifting magnet, press down on the red ignition fuse button. If the flame stops after the lifting magnet drops, the lifting magnet or the ignition fuse must be adjusted.

## 2. Interior Light

In the factory setting, the AESII electronics control the lighting. If there is a lighting defect, first check the light. If the lighting does not function even if the light is intact, you must proceed as follows:

1. Disconnect and insulate the white and yellow cable on the connecting terminal (A).
2. Connect the B and C connections of the connecting terminal together to test them.

If the lighting functions, use a 15-Ohm resistor with spare part number 295 1749-10/6 in the connecting terminal as a connection.

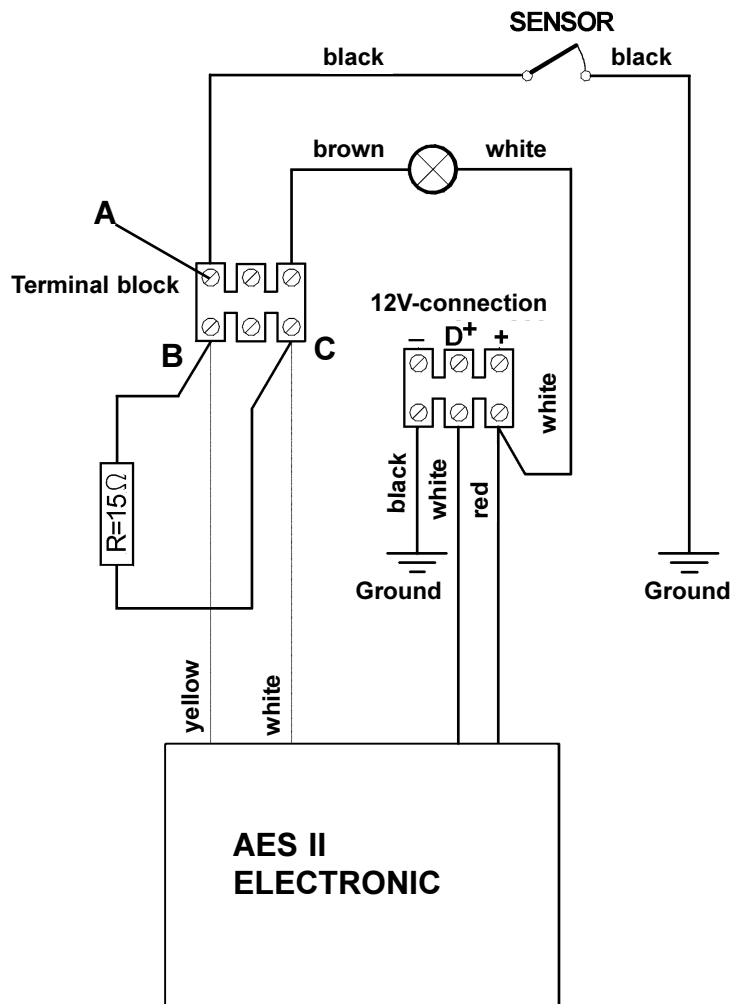

# 6.0 Wiring Diagram

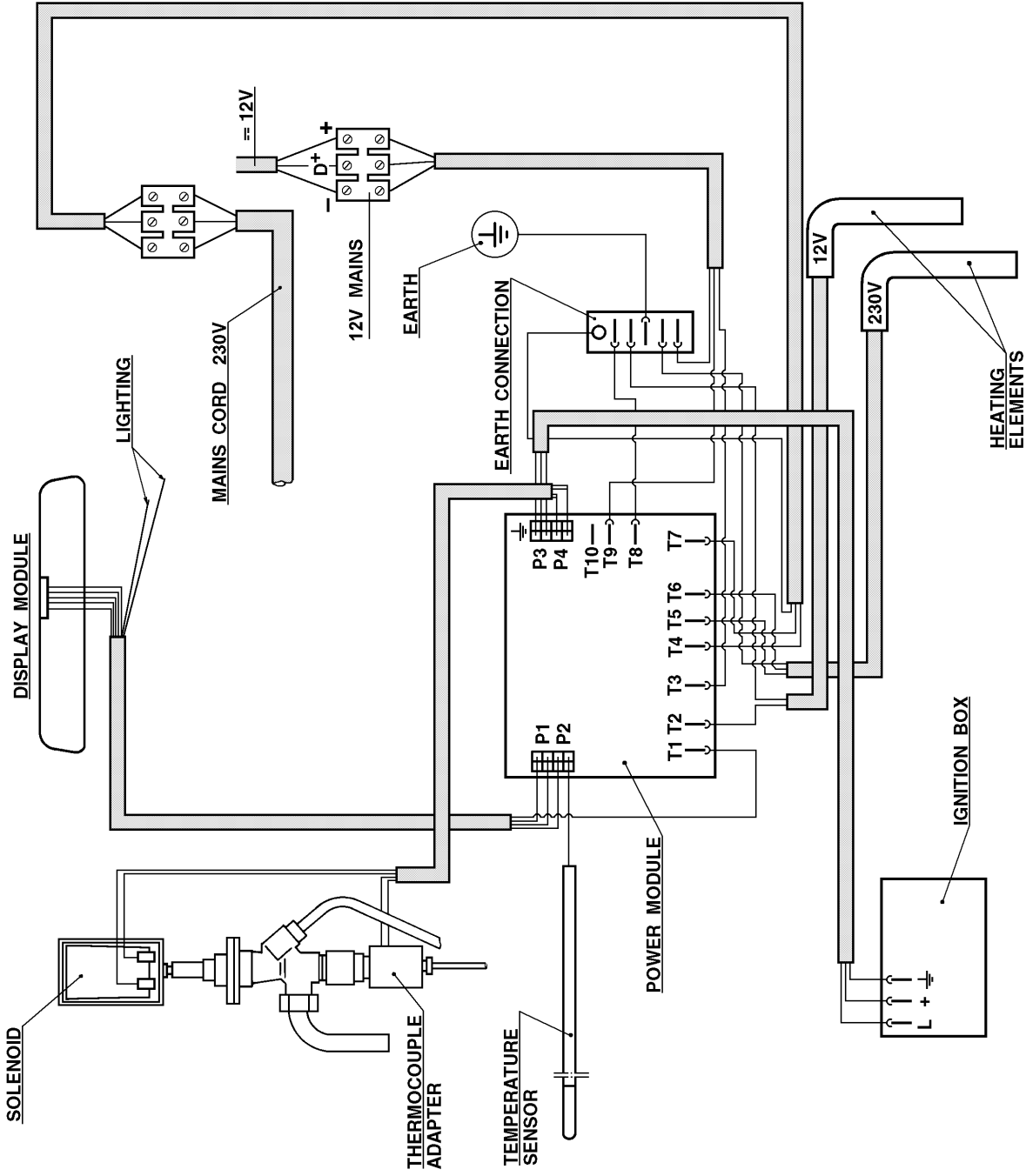

## 7.0 Spare Parts Numbers for the Functional Parts

Thermocurent adapter	295 1956-20/6
Ignition fuse	295 1157-10/2
Hexagon nut	280 1043-02/3
AESII-electronic	295 1876-10/7
3 amp AC fuse	294 3541-00/9
20 amp DC fuse	210 6389-10/5
Lifting magnet	295 1151-00/6
Temperature sensor cpl. wih cable	295 2072-00/3

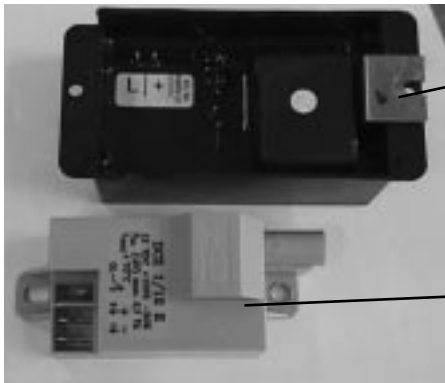

Old version of the reigniter (Fa. Cramer)  
295 1654-10/8

**Bulletin 599 4716-54/5,  
Note page 13 and 14**

New version of the reigniter (Anstoss Company)  
295 2368-00/5

## SERVICE BULLETIN

ELECTROLUX SIEGEN GmbH, In der Steinwiese 16, D-57074 Siegen

RM4185LM, RM4215LM, RM4235LM, RM4275LM, RM4285LM, RM4365LM, RM4405LM, RM 5405LM

### New electronic for AES-Caravan fridges in connection with the reigniter DCZ 1/12 E

The electronic of the AES II products had to be modified in order to make it possible that all Caravan refrigerators out of Siegen production can be operated with the same reigniter.

The consequence is that the following points must absolutely be observed:

- The AES II-electronic with the part no. 295 1876-00/8 used up to now **is replaced** by the new **AES II-electronic with the part no. 295 1876-10/7**.
- The reigniter (Messrs. Cramer) with part no. 295 1654-10/8 has to remain as spare part for the previous AES II-electronic 295 1876-00/8!
- When exchanging the previous AES II-electronic 295 1876-00/8 against the **new** one 295 1876-10/7 the Cramer-reigniter no. 295 1654-10/8 can remain installed.
- The reigniter with the part no. 295 2363-01/4 (Messrs. Anstoss) can only be used in connection with the new electronic 295 1876-10/7. In this case the new connection cable (AES II-electronic - reigniter) with the part no. 295 2047-13/8 has to be used.

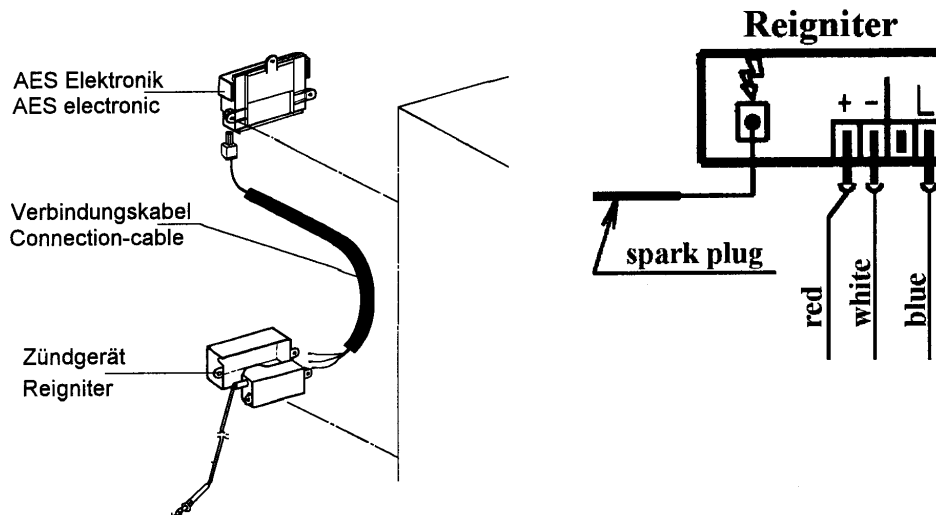

Publication-No.: 599 4716-54/5 / Service 97.04.08 B.O.

## Connection Reigniter

Connection new AESII- elektronik with reigniter ,  
messrs. cramer, spare part number 295 1654-10/8  
(the white flex is not used in thi s case).

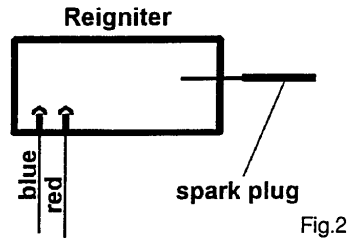

Connection new AESII- elektronik with reigni-  
ter cpl., messrs. Anstoss, spare part number  
295 2368-00/5.

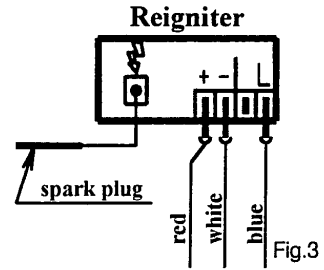

## Servicevariants electronics with reigniters

NEW AESII-electronic  
2951876-10/7

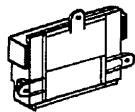

Fig.4

OLD AESII-electronic  
2951876-00/8

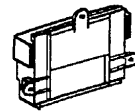
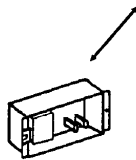
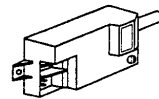

Fig.5



Reigniter old version (Cramer)  
Spare part number 295 1654-10/8



Reigniter new version (Anstoss)  
spare part number 295 2368-00/5

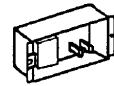

Reigniter old version (Cramer)  
spare part number 295 1654-10/8

### SERVICE BULLETIN

Reg. No.:447/97

ELECTROLUX SIEGEN GmbH, In der Steinwiese 16, D-57074 Siegen

RM4185, RM4215, RM4235, RM4265, RM4275, RM4285, RM4365, RM 4405, RM5215, RM5275, RM5405

#### AES II. obstruction by gas operation

##### OBSTRUCTION:

After ignition of the flame it may happen, that after about 30 seconds the flame extinguishes, the ignition cut-off and the operating display shows gas obstruction (flashing indicator red LED)

The reason of the obstruction is a defective connection between ignition cable (A) and spark plug (B).

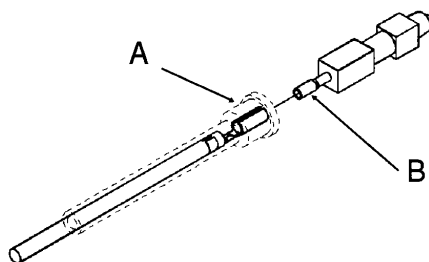

Sparks will be produced and the flame will be ignited, however the connection is so bad, that there is no acknowledge for flame-recognition to the reigniter.

The consequence is, the reigniter ignites so long, until the main-electronic cuts-off the ignition inflammation after 30 seconds.

##### FAILURE CORRECTIVE ACTIONS:

In service-fall, please change the spark plug cpl. with cable, spare part number 295 1105-31/7.

## SERVICE BULLETIN

ELECTROLUX SIEGEN GmbH, In der Steinwiese 16, D-57074 Siegen

RM4185LM, RM4215LM, RM4235LM, RM4275LM, RM4285LM, RM4365LM, RM4405LM, RM 5405LM  
RM 4505, RM 4605, RM 4705, RM 4805

### Thermocouple adapter and gas safety device AESII

Since there have been several problems in gas mode with AESII devices, we will introduce **new thermocouple adapters with spare part no. 295 1956-20/6** and **separately tested gas safety devices with spare part no. 295 1157-10/2** from January 1999.

The new thermocouple adapter can be identified by the colouring "black" or by the label "99"  
It should be basically used in case of problems in gas mode.

If this thermocouple adapter is destined to be used in RM 4505, 4605, 4705 and 4805 it is absolutely necessary to screw **the nut with spare part no. 280 1043-02/3** between thermoelement and thermocouple adapter.

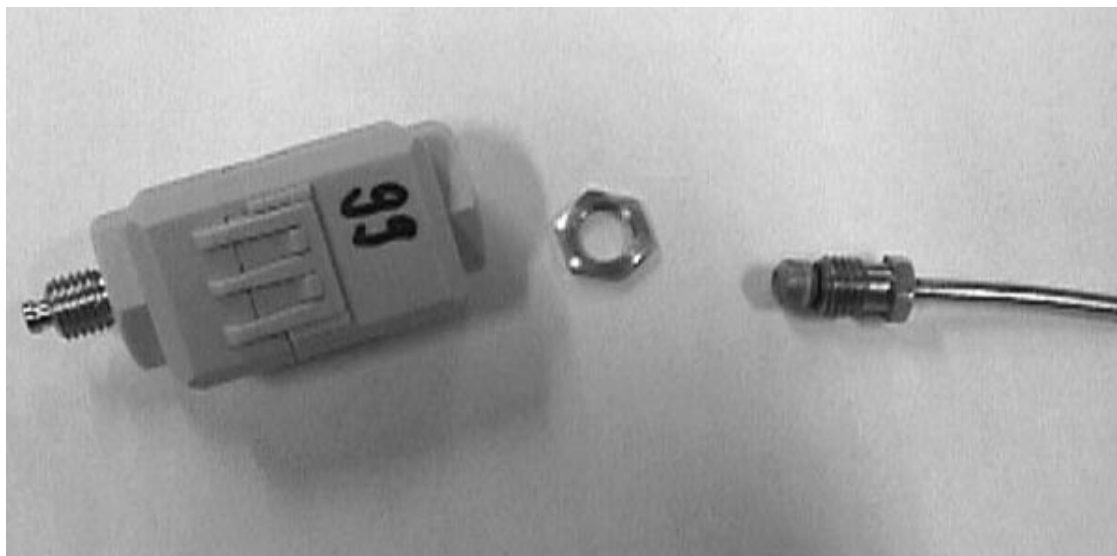



# 9.0 Operation of AES II with solar charging regulators

## Operation of Electrolux refrigerators with AES II control and solar charging regulators.

It is currently possible to operate Electrolux AES refrigerators using two types of solar charging regulators which are equipped with an AES output signal:

SR 240 DUO (Votronic, Grebenhain, Tel: +49-(0)-6644-7544  
 SAC50X or SAC50E (Solar Display Controller) with matching charging regulator (Meyer Solartechnologie, 88682 Salem, Tel: +49-(0)-7553-60508

Both of these solar charging regulators, when used in conjunction with an AES II, will ensure correct operation of an AES II refrigerator equipped with a solar charging regulator and simultaneously offer battery discharge protection.

It is important that the connection instructions provided by the manufacturer of the solar charging regulator are adhered to. Please note that the solar input of the AES is a sensor input, which must be connected to the corresponding sensor output of the solar charging regulator. Do not connect the standard 12V output (commonly referred to as on-board power supply +) as this would result in continuous 12V operation of the refrigerator and the battery would be completely discharged in a very short time. The solar input of the AES has a function similar to the D+ input, which will only allow 12V operation with the motor (generator) running, and if sufficient power is available for 12V operation.

Due to the high current flow required for 12V operation the solar unit must be able to provide at least 10-12 amperes, even when full sunlight is not available, to prevent overloading the on-board battery.

Correct operation of the refrigerator cannot be guaranteed with all other kinds of connection, particularly when solar charging regulators without AES switching outputs are used.

### 1. Connection diagram (separate connections for battery and on-board power supply)

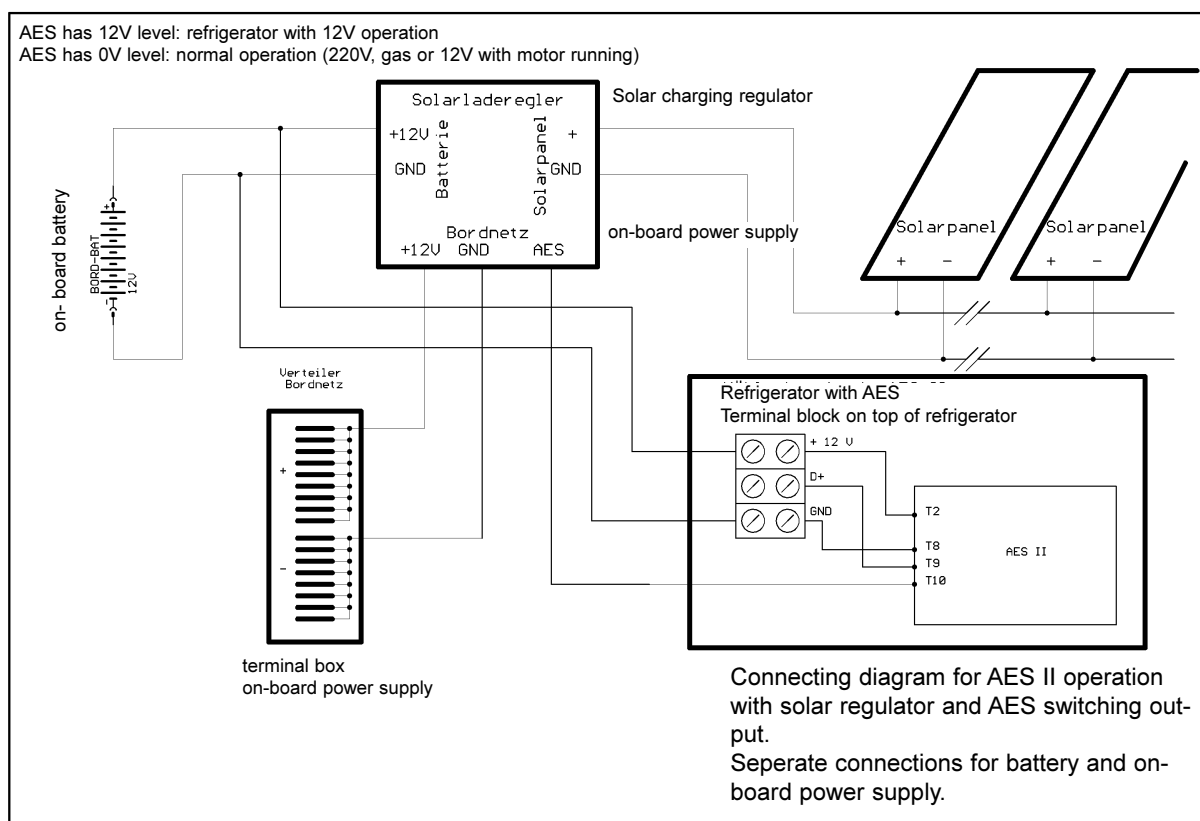

## 2. Connection diagram (shared connection for battery and on-board power supply)

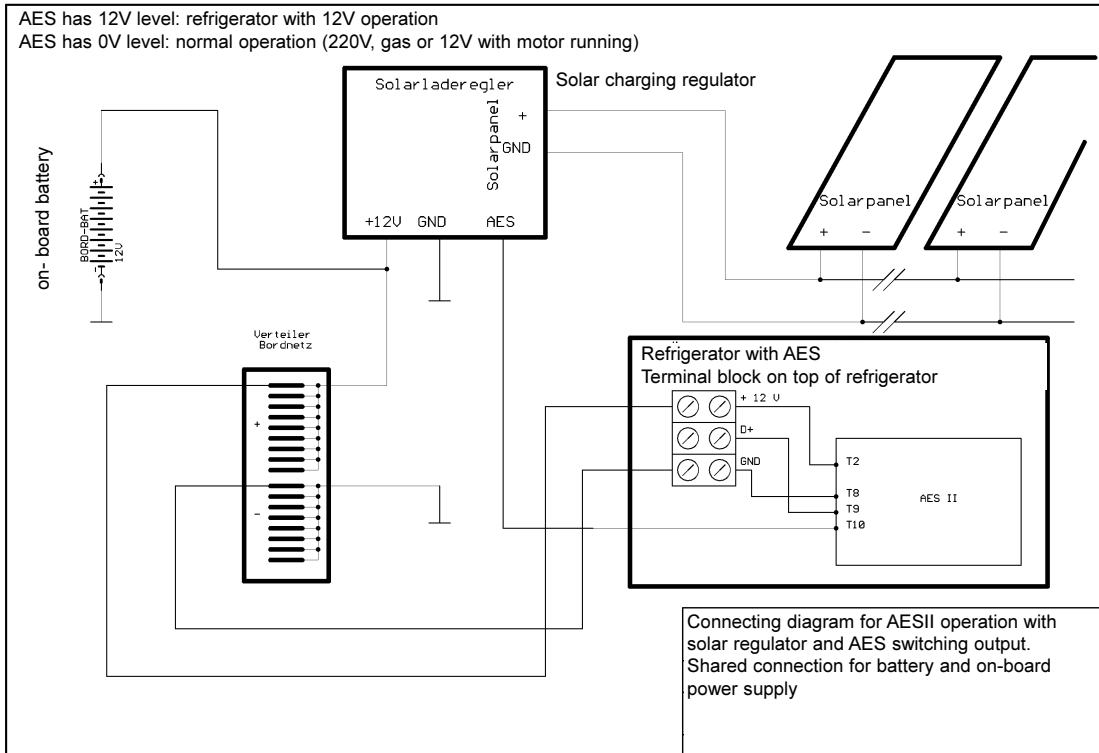



Electrolux Siegen GmbH  
In der Steinwiese 16  
D-57074 Siegen

Tel.: 0271 / 692-0  
Fax.: 0271 / 692 - 300