



<p>© ELECTROLUX HOME PRODUCTS ITALY S.p.A. Spares Operations Italy Corso Lino Zanussi, 30 I - 33080 PORCIA /PN</p> <p>Fax +39 0434 394096</p> <p>Edition: 2007-02-13</p>	<p>Washing machines with electronic control system</p> <p>EWM3500</p> <p>Technical and functional characteristics</p> <p>STYLING: TC1</p> <p>With cabinet</p> <p>ICON</p>	

CONTENTS

1	Purpose of this manual	5
2	PRECAUTIONS	5
2.1	During the delivery	6
2.2	During the reparation	6
3	TC1	7
3.1	GENERAL CHARACTERISTICS	7
3.2	CONTROL PANEL	8
3.2.1	Styling TC1	8
4	Summary table of the main areas and their contents	9
4.1.1	First switching on	10
4.2	Configuration of control panel	11
4.2.1	Programme selector (S1)	11
4.2.2	BUTTONS AND LCD	12
4.2.3	Time DRIVEN	14
4.2.4	Washing phases	15
4.2.5	Control of the options set during the cycle	16
4.2.6	Washing cycle in pause	16
4.2.7	Stop or cancelation of a programme	17
4.2.8	End of cycle	17
4.2.8.1	Stand-by	17
4.2.9	Child lock	18
4.2.10	Memory	19
4.2.11	Wash Guide	20
4.2.11.1	Temperature Guide	20
4.2.11.2	Spin guide	21
4.2.11.3	Options guide	22
4.2.11.4	Stain guide	23
4.2.11.5	Demo	24
4.2.12	Settings	25
4.2.12.1	Language	25
4.2.12.2	Volume	26
4.2.12.3	Time	27
4.2.12.4	Luminosity	28
4.2.12.5	Contrast	29
4.2.12.6	Resetting the settings	30
4.2.12.7	Delayed start	31
5	DIAGNOSTIC SYSTEM	32
5.1	Access to diagnostic mode	32
5.2	Exiting diagnostic mode	32
5.3	Diagnostic phases	33
5.3.1	Analysis of the LCD display during the diagnostic cycle	34
6	ALARMS	35
6.1	Displaying the alarms to the user	35
6.2	Reading the alarm codes	36
6.2.1	Displaying the alarm	37
6.2.2	Examples of alarm display	37
6.2.3	Operation of alarms during diagnostics	37
6.3	Rapid reading of alarm codes	38
6.4	Cancelling the last alarm	38
6.5	Cancelling the memories	39
7	OPERATING TIME COUNTER	39
8	WASHING PROGRAMMES AND OPTIONS	40
8.1	Programmes	40
8.2	Options	41
8.2.1	Compatibility between Options	43
8.3	Description of options	44
9	TECHNICAL CHARACTERISTICS	46
9.1	Control system memory	46
9.1.1	General structure of the memory system	46
9.1.2	FLASH	46
9.1.3	RAM	47
9.2	Door interlock	48
9.2.1	Voltmetric interlock with PTC	48
9.2.1.1	Operating principle	48
9.2.2	Instantaneous door interlock	49

9.2.2.1	Operating principle	49
9.2.2.2	Conditions required for opening the door.....	49
9.2.2.3	Automatic unlock	49
9.3	Water fill system	50
9.4	Analogue pressure switch of water level control in the tub	50
9.5	Drain pump	51
9.6	Recirculation pump (if featured).....	51
9.7	Heating.....	52
9.8	Temperature sensor	52
9.9	Three-phase asynchronous motor.....	53
9.9.1	Power supply to motor	53
9.10	Anti-foam control system.....	54
9.11	FUCS (Fast Unbalance Control System).....	55
9.12	Table of alarm codes.....	57
10	Diagram with THREE-PHASE ASYNCHRONOUS MOTOR	60
11	ACCESSIBILITY	62
11.1	To the electronic control system	62
11.1.1	Work top	62
11.1.2	Control panel	62
11.2	Door interlock	64
11.3	New drain filter	65
11.4	Inverter board.....	66

1 Purpose of this manual

The purpose of this manual is to provide service engineers who are already familiar with the repair procedures for traditional washing machines with information regarding appliances fitted with the ENV06 electronic control system and produced in Porcia (Italy).

The characteristic of the ENV06 electronic control system is to use only an electronic pressure switch to check the various water levels in the tub (with the elimination of the mechanical pressure switches: anti-overflow, anti-boiling, 1st-2nd level), and a new heater with two thermal fuses which interrupt if the temperature degree overcomes the values by which they are calibrated.

The following are described:

- general characteristics
- control panel and washing programmes
- technical and functional characteristics
- access to the electronic control system

For detailed information concerning hydraulic circuit, structural characteristics of the appliances and accessibility, please refer to Service Manual:

- *Publication no. 599 37 47-13 – washing machines with HEC cabinet.*

2 PRECAUTIONS



- **Electrical appliances must be serviced only by qualified Service Engineers.**
- **Always remove the plug from the power socket before touching internal components.**
- **In case of replacement of the heater, replace it with one with the same characteristics in order not to compromise the safety of the appliance.**
- **Before laying down the appliance, always drain the water through the appropriate system placed near the drain filter.**
- **Do not lay down the appliance on the right side (electronic control side): some water could come out from the detergent drawer that would deposit on the electrical components with possible burnings.**

2.1 During the delivery

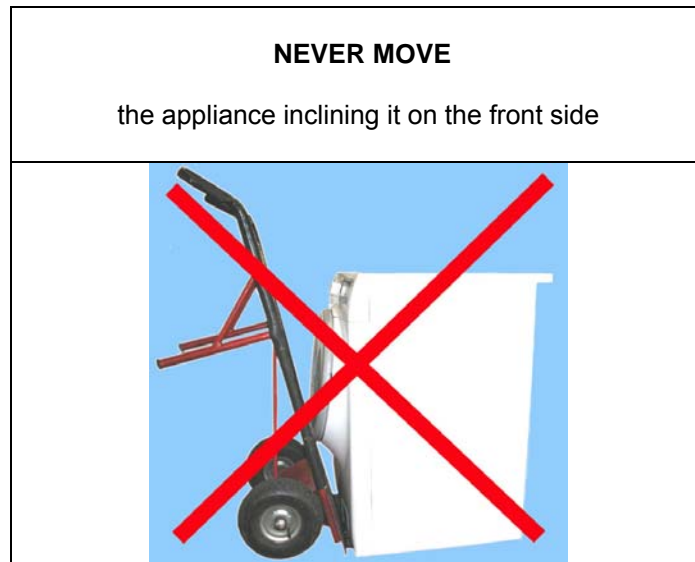

2.2 During the reparation

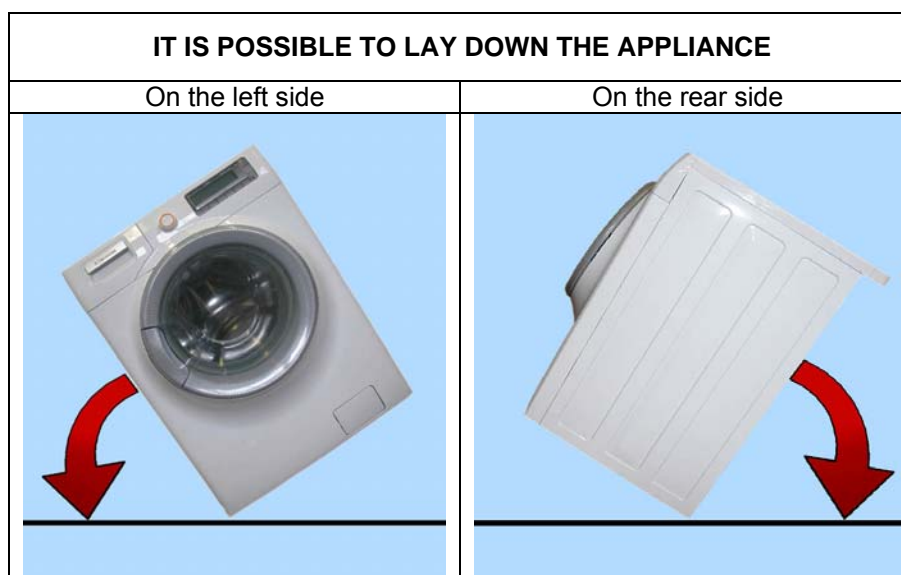
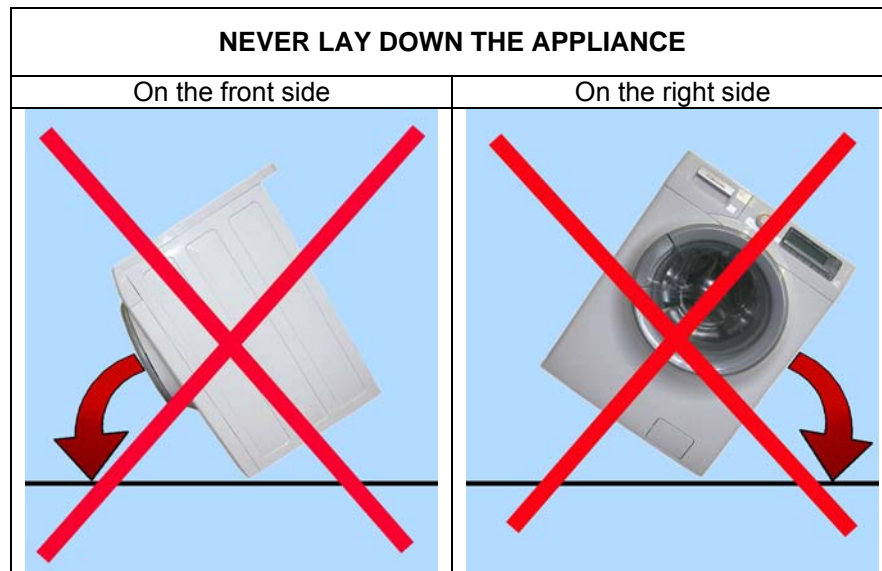

3 TC1

3.1 GENERAL CHARACTERISTICS

The ENV060 electronic control system consists of two electronic boards. One integrates the power and control functions and the selector, the other the display function, where also the LCD display is connected.

The PCB is mounted on a casing fitted to the control panel.



Version TC1	
Number of buttons	<ul style="list-style-type: none"> ▪ Max. 8 (5 options + 1 start/pause + 2 for time driven)
Number of LEDs	<ul style="list-style-type: none"> ▪ Max. 2 + LCD display
Programme selector	<ul style="list-style-type: none"> ▪ 15-21 positions with main switch (incorporated in the PCB)
Serial port	<ul style="list-style-type: none"> ▪ DAAS-EAP communications protocol up to 115.200 baud
Power supply	<ul style="list-style-type: none"> ▪ 220/240V ▪ 50/60 Hz (configurable)
Type of washing	<ul style="list-style-type: none"> ▪ Jet-system
Rinsing system	<ul style="list-style-type: none"> ▪ Jet-system
Motor	<ul style="list-style-type: none"> ▪ Two-pole asynchronous, with three-phase tachometric generator (with Inverter)
Spin speed	<ul style="list-style-type: none"> ▪ 600 ÷ 1800 g'
Anti-unbalancing system	<ul style="list-style-type: none"> ▪ FUCS
Water fill	<ul style="list-style-type: none"> ▪ 1 solenoid valve with 1 inlet – 2/3 outlets
Detergent drawer	<ul style="list-style-type: none"> ▪ 3 compartments: prewash/stains, wash, conditioners ▪ 4 compartments: prewash/stains, wash, conditioners, bleach
Control of water level in the tub	<ul style="list-style-type: none"> ▪ Electronic/analogue pressure switch
Door safety device	<ul style="list-style-type: none"> ▪ Traditional (with PTC) ▪ Instantaneous
Power of heating element	<ul style="list-style-type: none"> ▪ 1950W with thermal fuses incorporated
Temperature control	<ul style="list-style-type: none"> ▪ NTC sensor incorporated in the heater
Board with loudspeaker	<ul style="list-style-type: none"> ▪ Board with emits some musical motifs
Sensors	<ul style="list-style-type: none"> ▪ Water fill gauge (flowmeter) ▪ Aqua control

3.2 CONTROL PANEL

3.2.1 Styling TC1

- max. 8 buttons
- 15 or 21-position programme selector
- LEDs 2
- LCD display

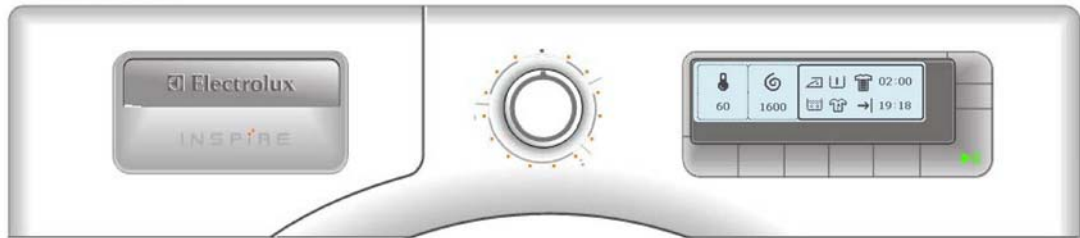

- Disposition of LEDs and buttons

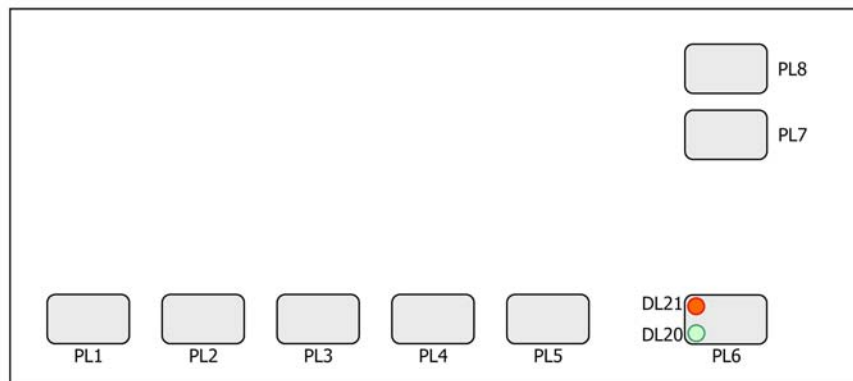

4 Summary table of the main areas and their contents

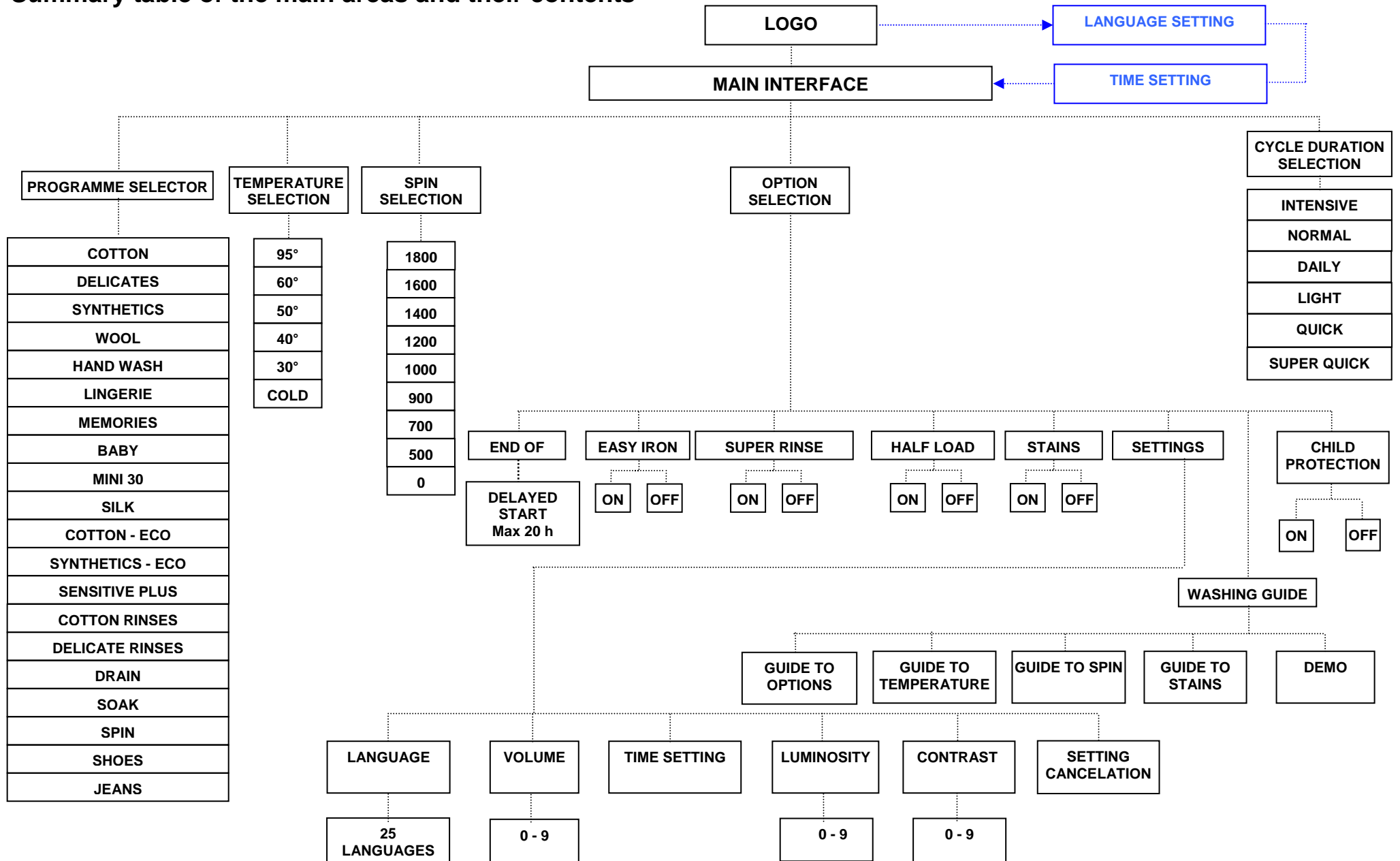

4.1.1 First switching on

When the appliance is switched on for the first time the LCD display shows a logo (one of the various featured) as represented in figure and a musical introduction.

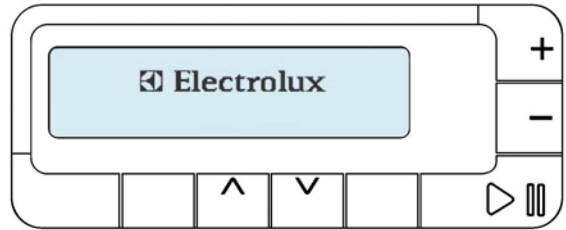

Pushing the 3 or 4 buttons it is possible to choose the appropriate language, between a list of 25 languages.

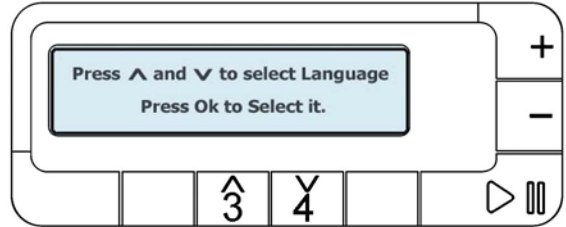

Once the language has been chosen, push OK 5 button twice

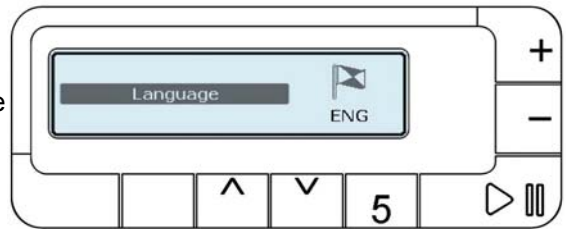

The screen for the time setting is displayed. The regulation is possible by pushing the 3 or 4 buttons respectively forward and backward. If they are pushed in sequence the variation is of one minute, while if they are pushed constantly the variation is of 10 minutes.

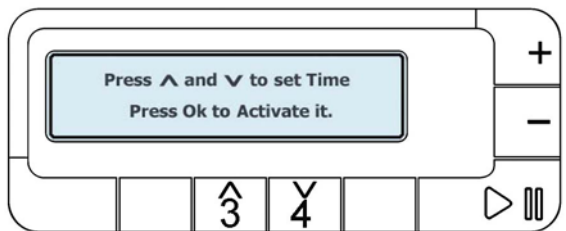

Push the OK (5) button to confirm the operation.

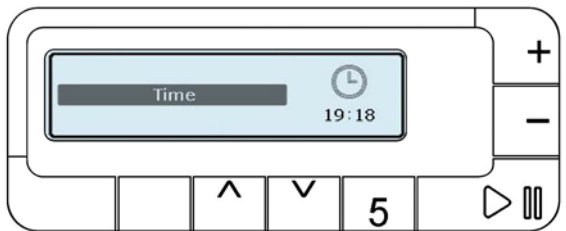

Once the initial settings have terminated, the selected programme is shown.



4.2 Configuration of control panel

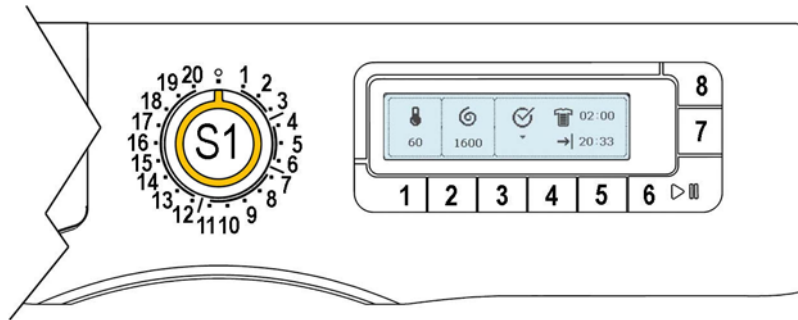

The washing programmes, the functions of the selector knob and the various pushbuttons vary according to the model, since these are determined by the configuration of the appliance.

4.2.1 Programme selector (S1)

The selector features 15-21 positions and incorporates the ON/OFF switch. The various positions of the selector may be configured to perform different washing programmes (ex: water level, drum movement, no. of rinses and the washing temperature to be selected according to the type of clothes). It can be turned both clockwise and anti-clockwise.

In the first position, the appliance is switched off and the current programme is cancelled.

For each programme, the compatible options and other parameters are defined.



- **Programme configuration**

The table below lists the parameters that can be used to define the washing programmes.

Types of fabric	Cotton/linen, Synthetic fabrics, Delicates, Wool, Hand-wash, Shoes, Jeans, Duvet, Silk.
Special programmes	Soak, Miniprogramme, Easy-Iron, Conditioner, Rinses, Delicate rinses, Drain, Delicate spin, Spin.
Temperature	Normal, Maximum: the initial temperature is the maximum that can be selected for a specific washing programme.
Spin	Maximum, Normal, Minimum, Spin reduction, No spin, Night cycle and Rinse hold.
Options (Normal / Possible)	Prewash, Stains, Bleach, Extra rinse, Easy-iron, Economy (energy label), Daily, Half load.
Time Driven	Intensive, Normal, Daily, Light, Quick, Super quick.
Programme phases	Prewash, Wash, Rinses, Spin, Delayed start.

Turning the selector, the display shows the symbol and the name of the selected programme, in the lower part of the display a short description to help the user to choose the appropriate programme.

Continuing to turn the programme knob the display shows the other programmes with a short description.

5 minutes after choosing the programme the LCD display shows the basic settings (set by the factory).

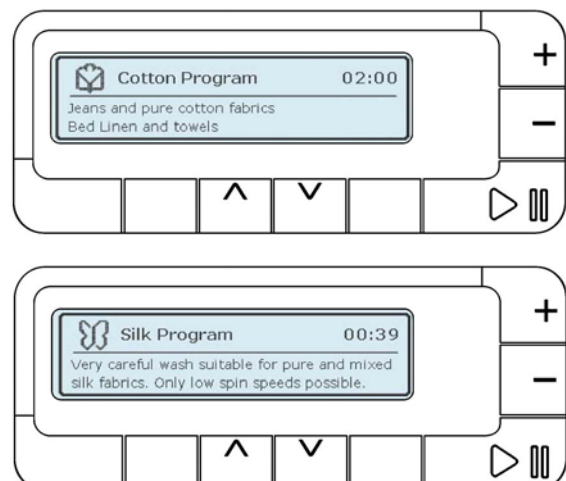

If they do not need to be modified, just push the START/PAUSE (6) button to start the washing programme.

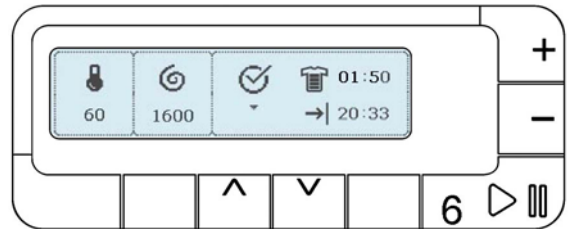

If the basic settings do not satisfy the needs, pushing the relative buttons in sequence it is possible to modify the wash cycle temperature, the spin speed and to choose the various options to combine with the programme.

4.2.2 BUTTONS AND LCD

◆ Button 1 “TEMPERATURE”

The temperature set by the programme is the base one. Pushing button 1 the temperature area appears: pushing it in sequence it is possible to modify it from a min to a max. and the thermometer symbol changes according to the chosen temperature.

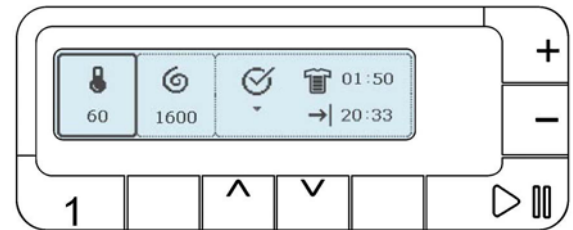

◆ Button 2 “SPIN”

The spin set by the programme is the base one. Pushing button 2 the spin area is shown, pushing it in sequence it is possible to modify the speed till zero to pass to “NIGHT CYCLE” and “STOP WITH RINSE HOLD”.

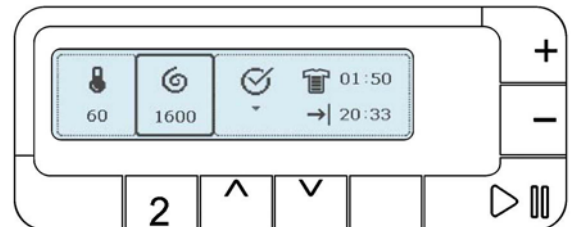

◆ Buttons 3-4 “OPTIONS”

Pushing buttons 3 or 4 it is possible to choose the options to combine with the chosen programme. Pushing one of the buttons, the time and option are shown, and simultaneously the list of the available options expands is shown.

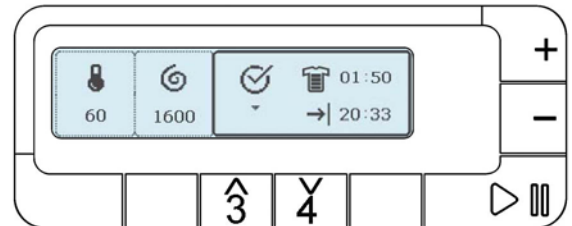

Pushing the buttons it is possible to navigate inside the list and simultaneously on the right upper side the symbol of the option and a short description appear.

If the symbol is crossed it means that is not active and the writing OFF appears below.

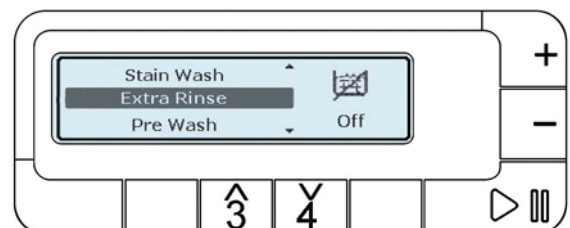

If the symbol is not crossed it means that is active and the writing ON appears below.

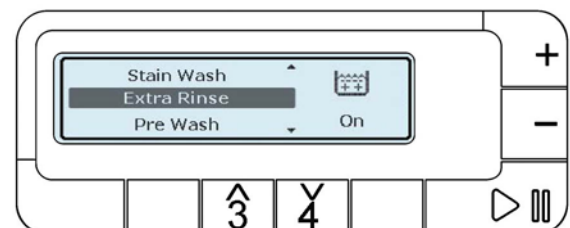

After 2 seconds the writing changes to "PUSH OK"; pushing button 5 it is possible to change the option state from active to inactive or vice versa.

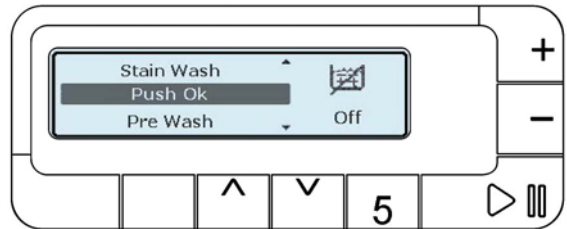

Once the options have been chosen to close the expanded area just push a button (for ex. temperature, spin, etc.) or wait some seconds, the main screen will be displayed with the selected options.

If the selected options are different the symbol dimensions will be proportionally reduced to the space available as represented in A two options, B three options, C four options.

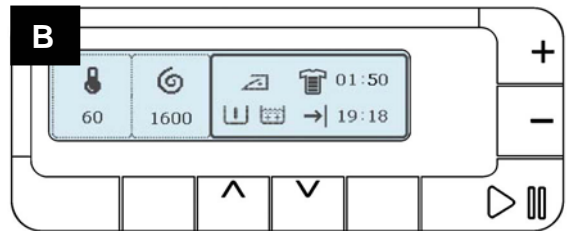
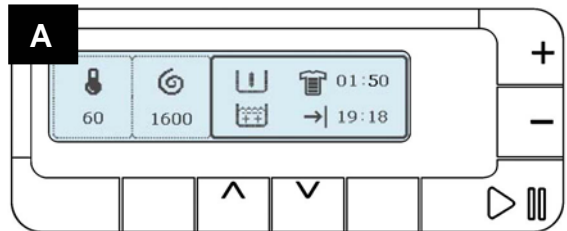

◆ Button 5 "OK"

It modifies and confirms the changes.

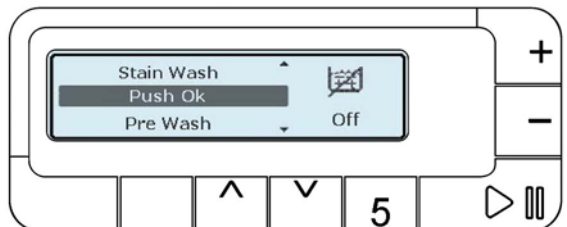

◆ Button 6 "START/PAUSE"

It has the START/PAUSE option (there are two LEDs: one red which flashes in case of alarm and one green which flashes when the appliance is in pause or in combination with the red one to indicate the alarm code), during the washing cycle the button remains constantly lit with green light.

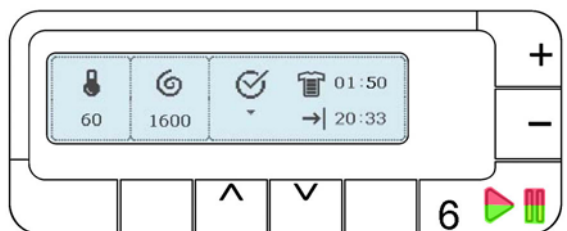

4.2.3 Time DRIVEN

The “Time driven” has the function to modify the programme settings according to the type of dirt so the wash time can be reduced or increased. Displaying the dirt level through an icon represented by a shirt and the time through the four digits positioned on the right side of the LCD display, this variation can be modified with buttons 7 and 8 positioned besides the display. The symbol remains lit for the whole duration of the programme.

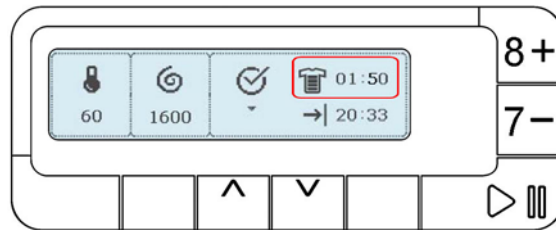

Find below the different levels according to the soil degree:

↪ Super quick (super rapid cycle) indicated for cottons and synthetics with light dirt level, and for half load.

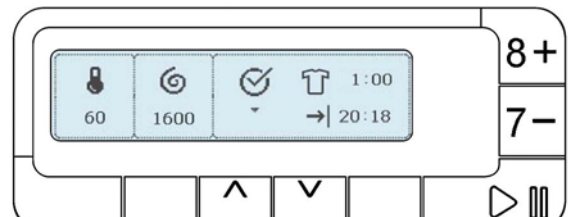

↪ Quick cycle indicated for cottons and clothes used just once.

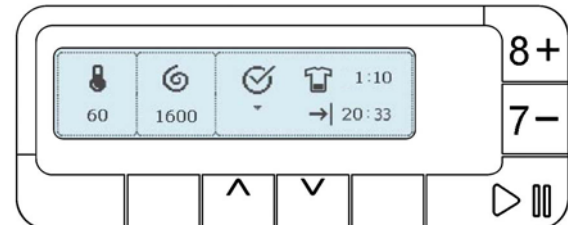

↪ Light cycle indicated for cotton and synthetics, for clothes slightly dirty or of daily use.

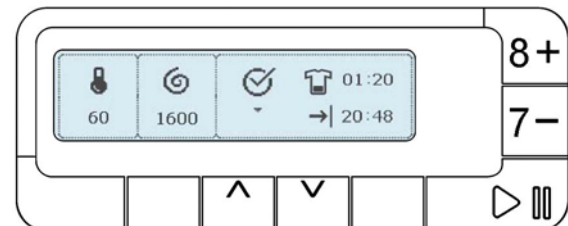

↪ Daily cycle indicated for cotton, synthetics and delicate and for quite dirty clothes.

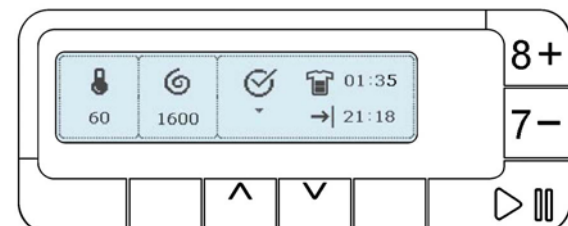

↪ Normal cycle indicated for cotton, synthetics and delicates, quite dirty clothes worn many times.

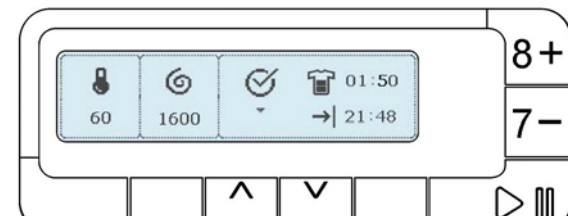

↪ Intensive cycle indicated for cottons, very dirty clothes which need anti-stain treatments, soak and prewash.

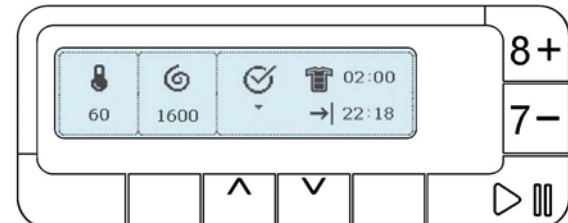

The levels are represented in the following table:

COTTONS	SYNTHETICS	DELICATES
INTENSIVE	-----	-----
NORMAL (basic programme)	NORMAL (basic programme)	NORMAL (basic programme)
DAILY	DAILY	DAILY
LIGHT	LIGHT	LIGHT
QUICK	-----	-----
SUPER QUICK	SUPER QUICK	SUPER QUICK

4.2.4 Washing phases

The washing cycle consists of six phases: water fill, washing, rinses, drain, spin and end of cycle. They are represented through the LCD display with the name of the current phase and with some little bubbles which stand for the water. Four digits in the upper right side indicate the time to end of the cycle, the four digits in the lower right side indicate the time at which the cycle terminates.

↶ **Water fill:** represented alternatively by a bubble movement and the name of the chosen programme.

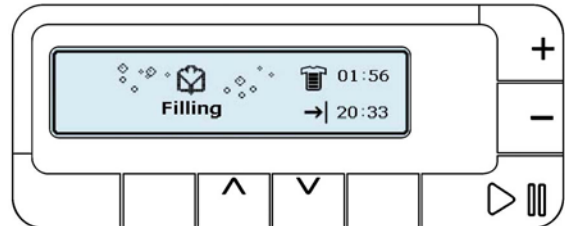

↶ **Washing:** represented by a casual movement of bubbles.

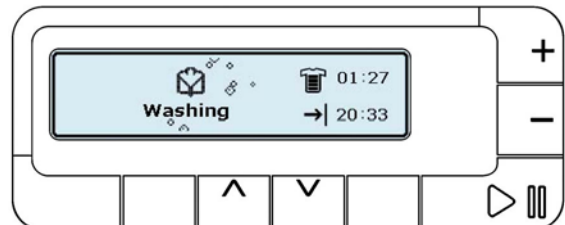

↶ **Rinsing:** represented by a horizontal movement of bubbles like a wave.

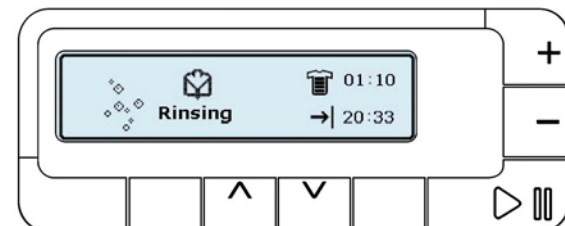

↶ **Draining:** represented by a bubble movement downwards to indicate the exit of the water from the drum.

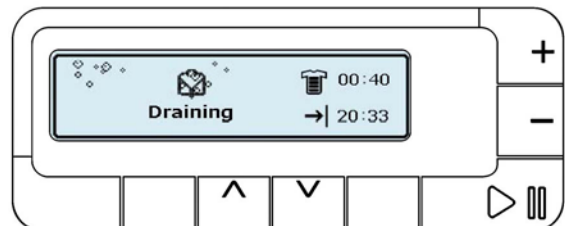

↶ **Spinning:** represented by a circular movement of bubbles like the rotary movement of the drain phase.

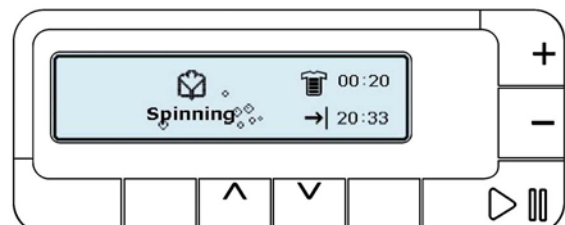

When the cycle has terminated, the bubble animation disappears.

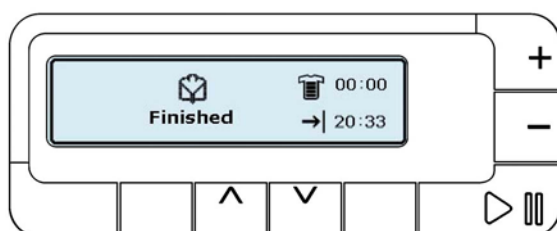

The door open symbol disappears to inform the user that it can be opened.

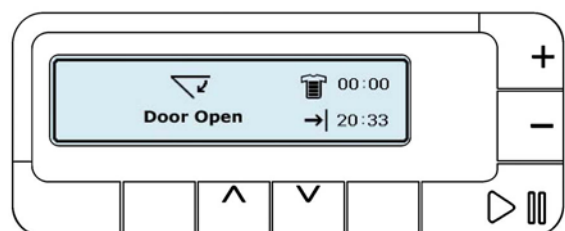

4.2.5 Control of the options set during the cycle

During the cycle the user can check the settings pushing a button: Temperature (1), Spin (2), Option (4-5) and OK (5).

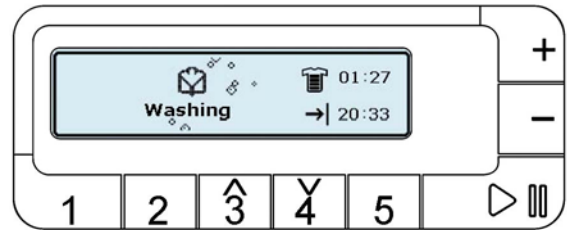

The main screen with all the indications appears.

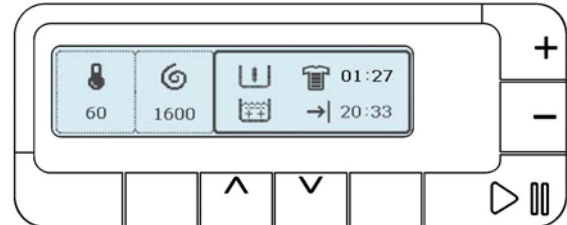

After five seconds the display returns to the previous screen.

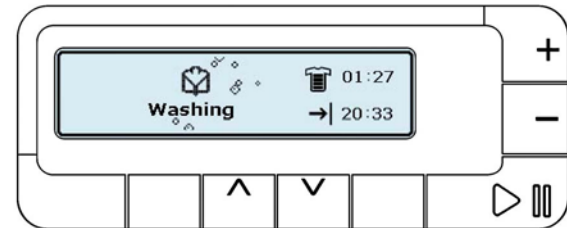

During the washing cycle, for many factors (drain filter dirty, etc.) the duration of the programme could slightly vary, thus causing the changing of the time to end proposed at the beginning of the cycle.

4.2.6 Washing cycle in pause

During the washing cycle the user can pause the washing programme pushing the button START/PAUSE (6).

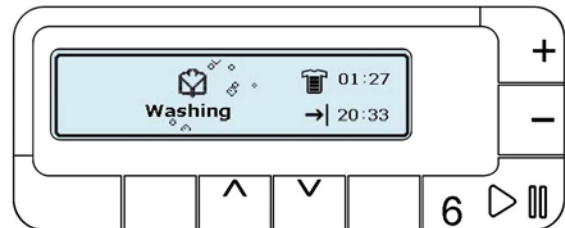

The LCD display represents some information: which button to push to continue the cycle (START/PAUSE 6).

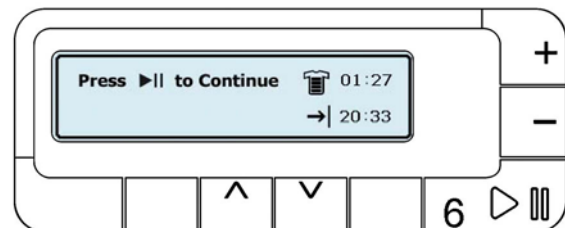

Some seconds after the symbol of cycle in pause is displayed.

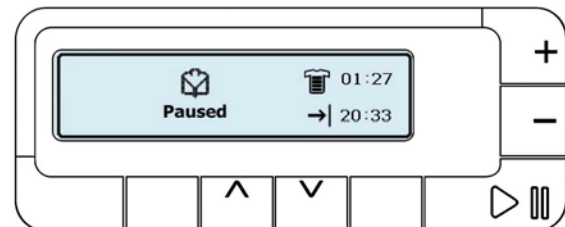

If the phase of the washing cycle which includes a pause corresponds to a condition by which the door can be open, the display will show the relative symbol.

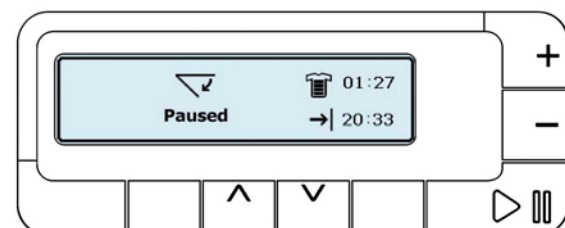

4.2.7 Stop or cancelation of a programme

When the washing programme has already begun.

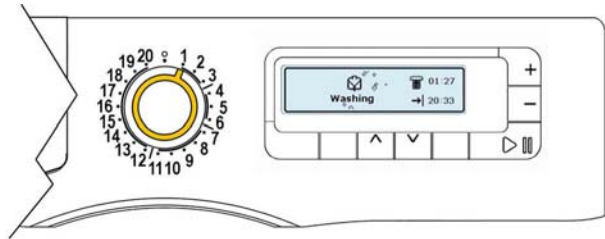

The user can stop it or cancel it by turning the programme selector to position 0 (zero, appliance off).

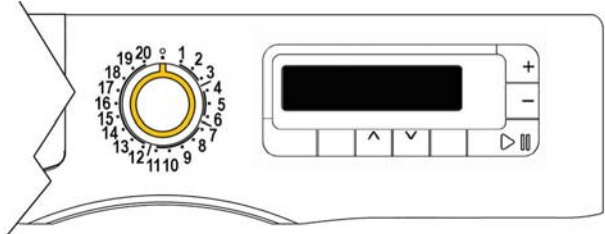

When the user switches the appliance on again, s/he will be required to confirm the cancellation or to continue the programme.

To cancel the programme, the user must push the button OK (5).

To continue the programme, the user must push the button START/PAUSE (6) and the cycle will start from the point at which it was interrupted.

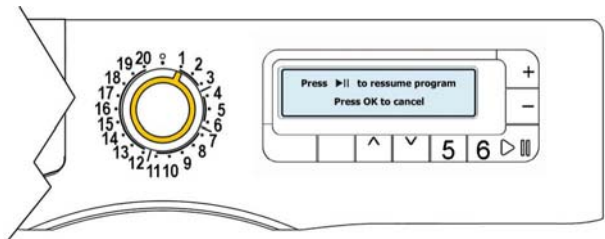

4.2.8 End of cycle

When the washing cycle has terminated also all the animations terminate and a text is shown to inform the user that the cycle has finished.

Simultaneously a melody starts (to inform that the cycle is finished). In the beginning it is quite frequent, then it becomes less frequent (for a max. time of 3 minutes).

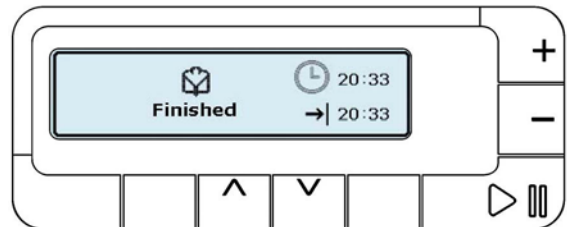

After some seconds the display shows that the door can be opened.

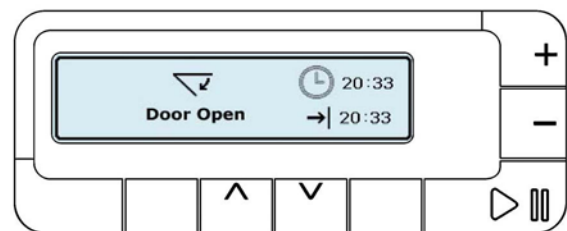

The user can deactivate the melody by turning the programme selector to position 0 (zero).

4.2.8.1 Stand-by

If the user does not push any button or does not turn the selector knob while the appliance is in selection mode or at the end of the washing cycle, the appliance is in STAND-BY after ten minutes. The LED of the START/PAUSE button flashes slowly, the light of the LCD display switches off, the symbols and the digits remain visible, the door interlock and the Inverter board are not powered.

The Delayed start phase is considered an active phase therefore the STAND-BY is not active.

When the user pushes a button, the appliance exits from the STAND-BY condition.

4.2.9 Child lock

Push buttons **3** or **4**, scroll down the menu till:

“CHILD LOCK”

Wait two seconds and the writing: “PUSH OK” button **5** appears.

After activating the child lock the screen changes to inform the user how to unlock the appliance at the end of the cycle (push simultaneously buttons 3 and 4 for five seconds). This screen lasts about ten seconds.

Then the screen shows the Child Lock active with the lock symbol not crossed and the writing below is ON.

The user can continue to use the appliance, because till button START/PAUSE (**6**) is not pressed, the Child Lock is not active.

Once the appliance has been locked this function remains active till the user unlocks it.

In this way the user can leave the washing machine with the door closed and the children do not get hurt nor can damage it.

After switching off and on the appliance the message of the Child Lock remains active till the user pushes buttons 3 and 4 simultaneously for five seconds so as to unlock the Child Lock.

The appliance returns to normal operation.

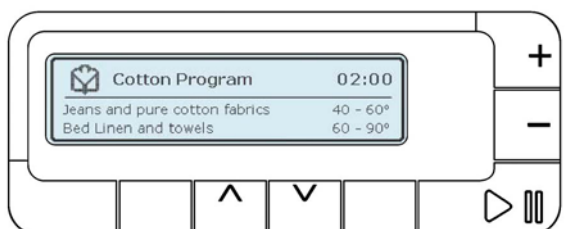
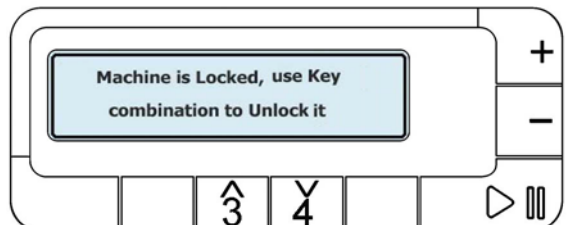
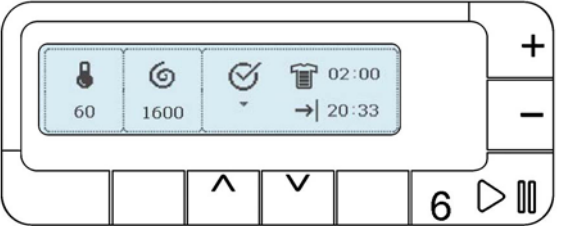
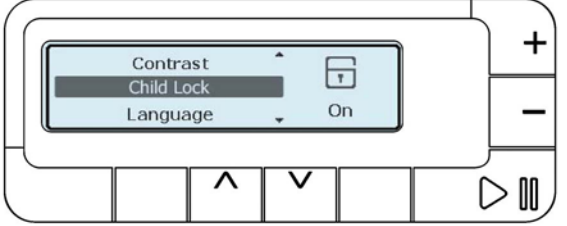
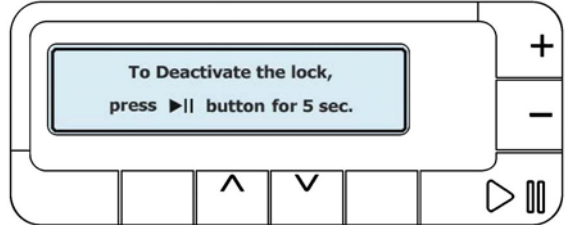
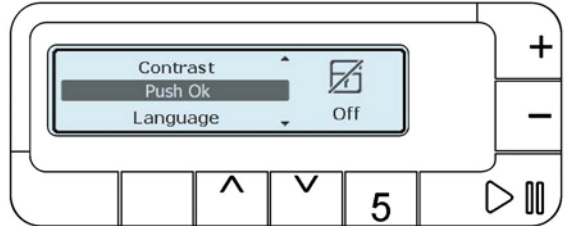
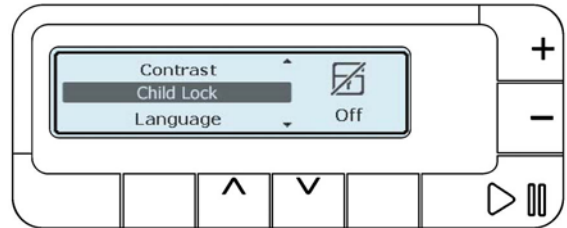
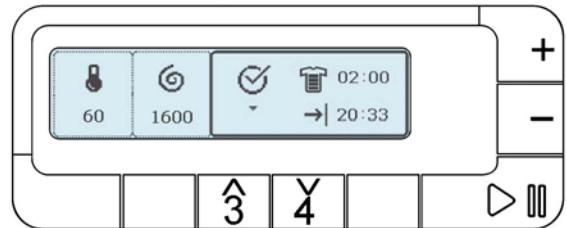

4.2.10 Memory

Some positions of the programme selector are dedicated to the memorization of washing cycles that the user can personalize, so as to avoid repeating the modifications to a programme, for ex. to the temperature, the spin speed and to the options.

If the appliance is new the memories are empty, so the user needs to define them.

Select a programme
Modify it if necessary

Push buttons 3 or 4, scroll down the menu till:

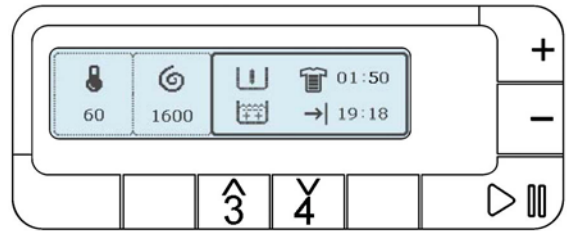

“SAVE FAVOURITE”

Push button OK (5).

Choose which memory to use to memorize the personalized programme.

Push button OK (5).

The writing “SAVED” appears.

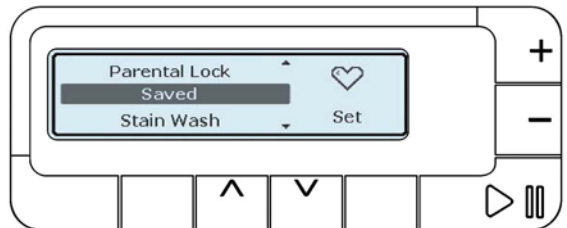
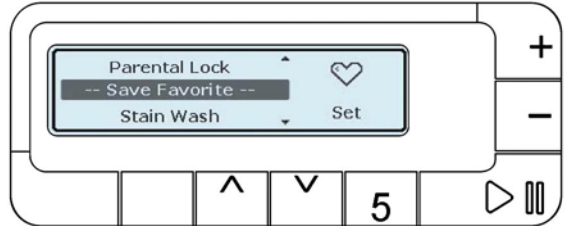

If by mistake the user selects a position in which a programme has already been memorized, the screen shows: Press OK to overwrite it (5).

While if you do not want to overwrite it, push OPTION button (3 or 4).

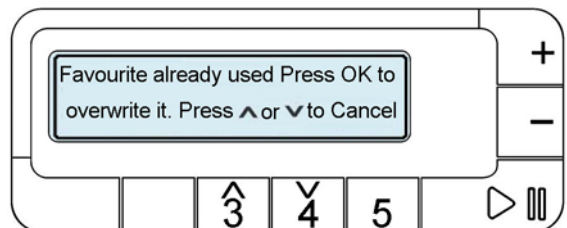

4.2.11 Wash Guide

Here the user can search for information about: the best programme to choose, the ideal cycle temperature, the optimal spin and the various options to combine, to obtain the best from the washing cycle.

The guide to the washing is inside the option menu.

Push buttons **3** or **4** and scroll down the menu till:

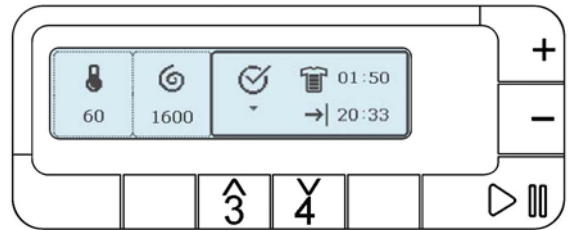

“WASH GUIDE”

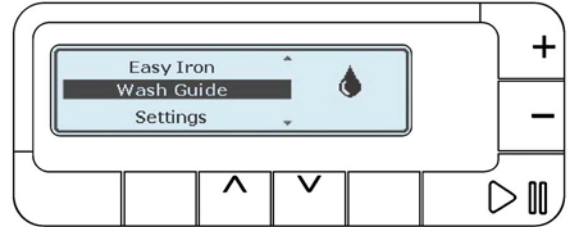

Wait two second, the writing changes to: “PUSH OK” button **5**.

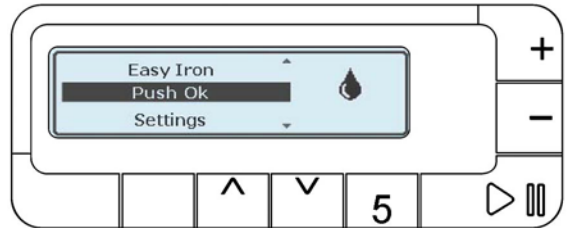

4.2.11.1 Temperature Guide

The writing “TEMP GUIDE” appears. Here the user can search for information about the temperatures to wash the clothes, so as to select the best one.

Push button OK (**5**).

The first description is shown.

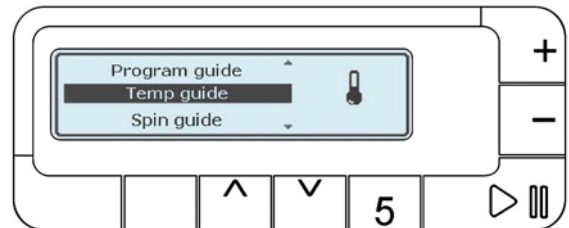

Pushing buttons **3** or **4** all the descriptions for the various temperatures are displayed.

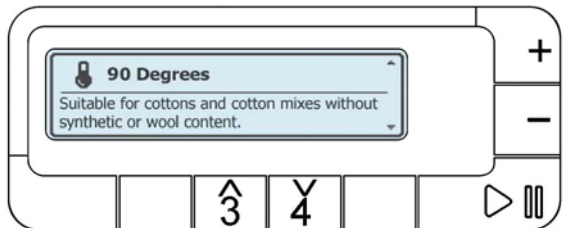

Waiting some seconds or pushing buttons: TEMPERATURE (1) or SPIN (2) or START/PAUSE (6) the main screen is displayed again.

Pushing button OK (5) the menu “TEMP GUIDE” appears again.

4.2.11.2 Spin guide

Here the user can search for information about the different spin speeds for the clothes, so as to choose the best one.

Push buttons **3** or **4** and scroll down the menu till:

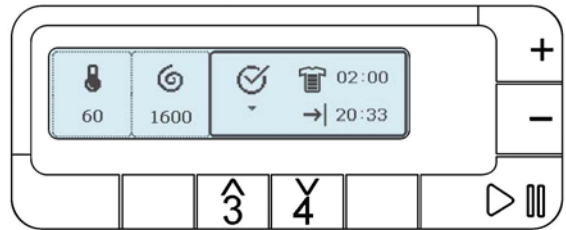

“WASH GUIDE”

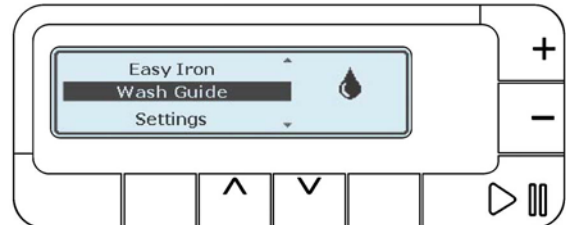

Wait two seconds the writing changes to:
“PUSH OK” button **5**.

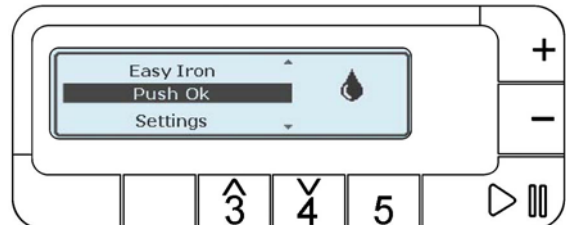

Push buttons **3** or **4** and scroll down the menu till:

“SPIN GUIDE”

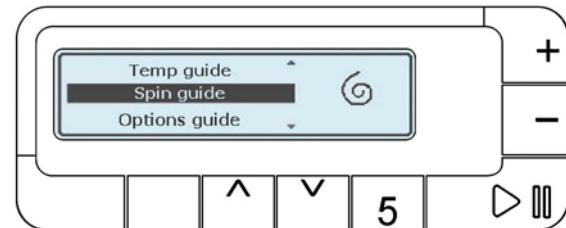

Push button OK (**5**).

The first description is displayed.

Pushing buttons **3** or **4** all the descriptions for the various spin speeds are displayed.

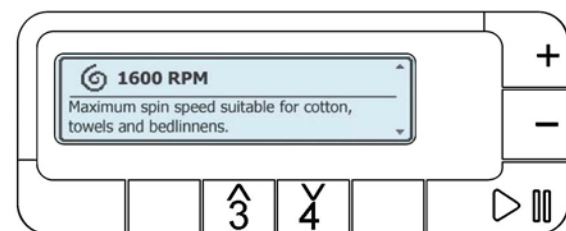

Waiting some seconds or pushing buttons: TEMPERATURE (1) or SPIN (2) or START/PAUSE (6) the main screen is displayed again.

Pushing button OK (5) the menu “SPIN GUIDE” appears again.

4.2.11.3 Options guide

Here the user can search for information about the available options to choose according to the clothes to be washed, so as to obtain the best result from their appliance.

Push buttons **3** or **4** and scroll down the menu till:

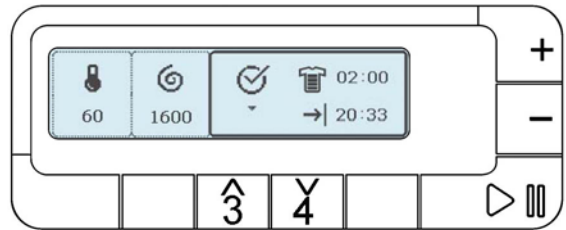

“WASH GUIDE”

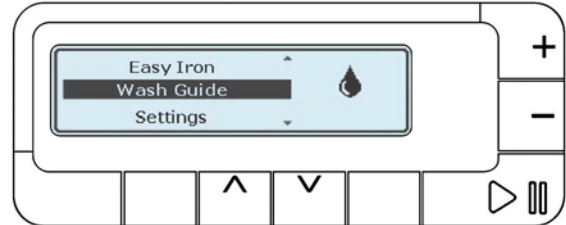

Wait two seconds the writing changes to:
“PUSH OK” button **5**.

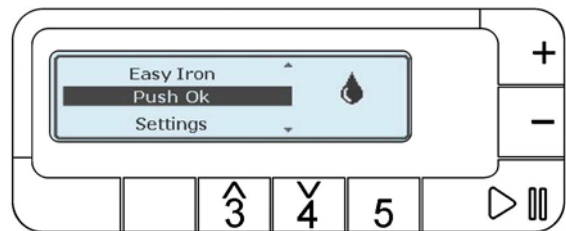

Push buttons **3** or **4** and scroll down the menu till:
“OPTIONS GUIDE”.

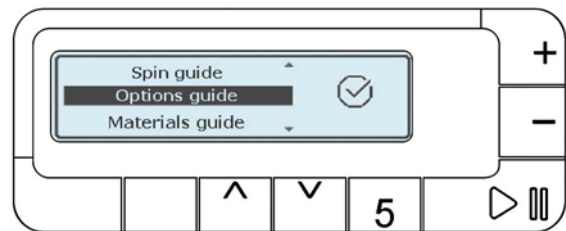

Push button OK (**5**).

The first description is displayed.

Pushing buttons **3** or **4** the other descriptions for the information relative to each option are displayed.

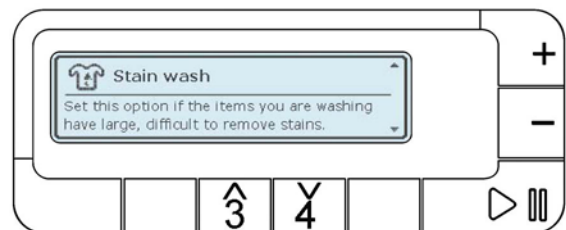

Waiting some seconds or pushing buttons: TEMPERATURE (1) or SPIN (2) or START/PAUSE (6) the main screen is displayed again.

Pushing button OK (5) the menu “OPTIONS GUIDE” appears again.

4.2.11.4 Stain guide

Here the user can search for information about how to remove heavy soil from different type of fabrics.

Push buttons **3** or **4** and scroll down the menu till:

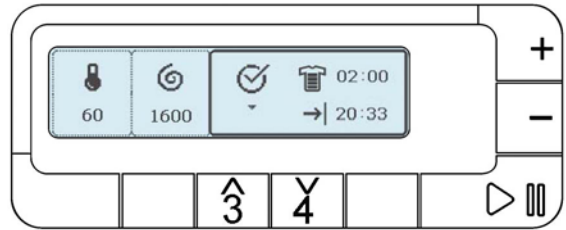

“WASH GUIDE”

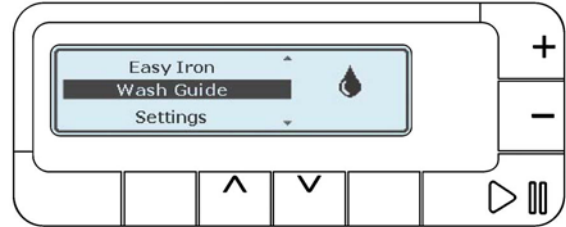

Wait two seconds the writing changes to:
“PUSH OK” button **5**.

Push buttons **3** or **4** and scroll down the menu till:

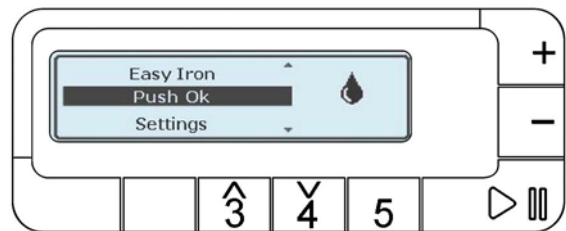

“STAIN GUIDE”

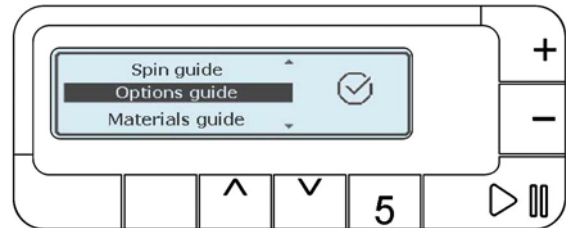

Push button OK (**5**).

The first description is displayed.

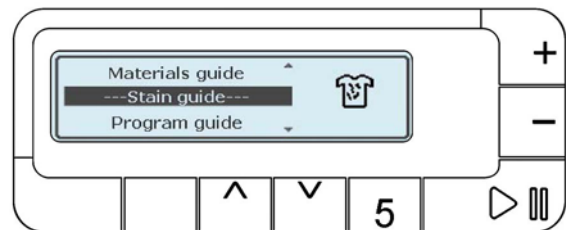

Pushing buttons **3** or **4** the other descriptions for the information relative to each type of stain are displayed.

Waiting some seconds or pushing buttons: TEMPERATURE (1) or SPIN (2) or START/PAUSE (6) the main screen is displayed again.

Pushing button OK (5) the menu “STAIN GUIDE” appears again.

4.2.11.5 Demo

A special cycle has been created for demonstration of the operation of these appliances in retail outlets without connecting the appliance to the water supply. In this way, the salesman can select any programme; after starting the cycle by pressing START, the appliance will perform certain phases only, and will skip those which cannot be performed (water fill, drain, heating).

The cycle takes place as follows:

- ↪ the door locking device is actioned in the normal way (i.e. the door remains locked while the appliance is in operation, and can be opened at the end of the cycle or in pause mode)
- ↪ motor: all low-speed movements are enabled, while the pulse signals and the spin cycle are excluded
- ↪ the water fill solenoids and the drain pump are disabled
- ↪ LCD: it displays all the programme phases rapidly
- ↪ alarms: for safety reasons the following groups of alarms remain enabled: E40 (door closed), E50 (motor) and E90 (communication between the boards/configuration).

Push buttons **3** or **4** and scroll down the menu till:

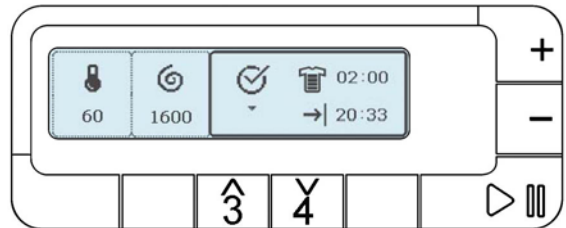

“WASH GUIDE”

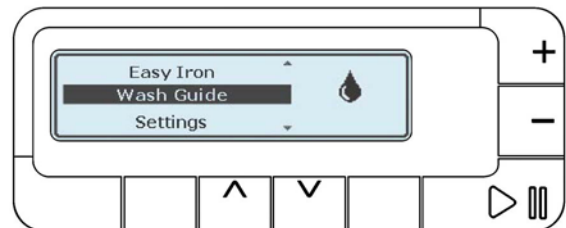

Wait two seconds the writing changes to:
“PUSH OK” button **5**.

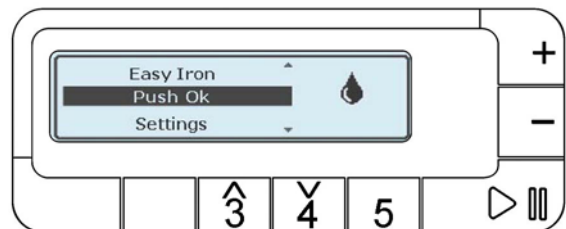

Push buttons **3** or **4** and scroll down the menu till:
“DEMO”

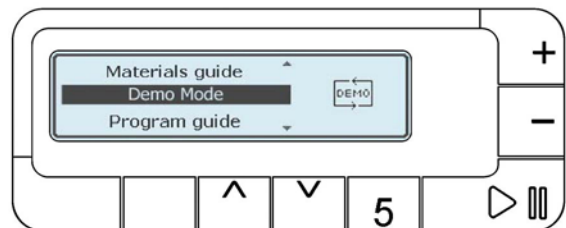

To activate the cycle push button OK (**5**).

To deactivate this function, just switch the appliance off, or repeat the DEMO mode and the display shows: DEMO Off.

The MEMO function can be activated continuously: switch the appliance off, push buttons OK (**5**) and START/PAUSE (**6**) simultaneously, and holding them down turn the selector of three positions clockwise for five seconds.

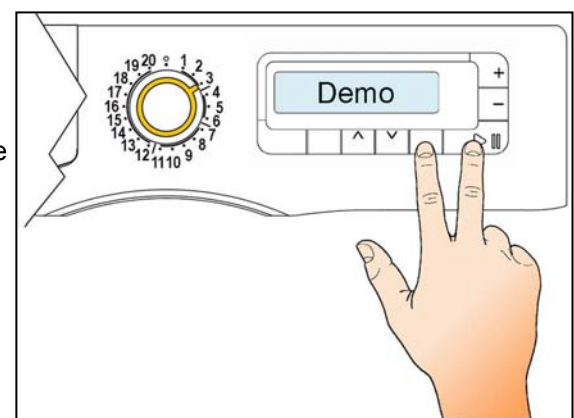

To terminate the cycle, repeat the same procedure and DEMO Off will appear.

4.2.12 Settings

The setting menu is inside the option menu.

Push buttons **3** or **4** and scroll down the menu till:

“SETTINGS”

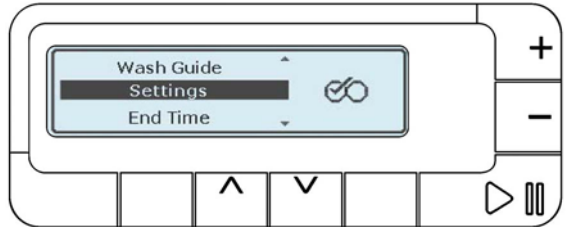
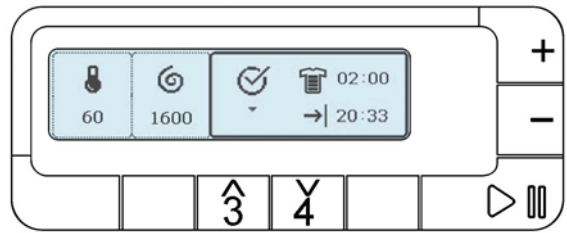

Wait two seconds the writing changes to:
“PUSH OK” button **5**.

4.2.12.1 Language

“LANGUAGE” appears on the display.

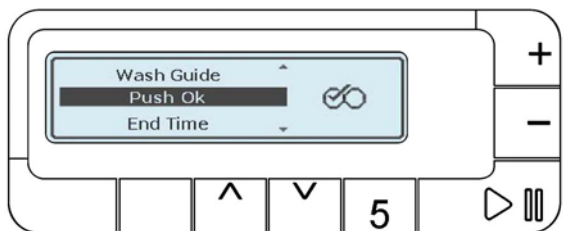

Push button OK (**5**).

The writing under the flag symbol starts to flash; now it is possible to scroll down the list of the available languages pushing buttons **3** or **4** in sequence. Choose the language and push button OK (**5**).

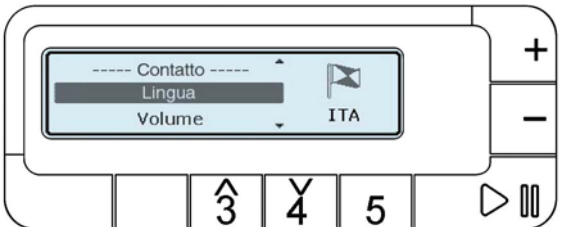
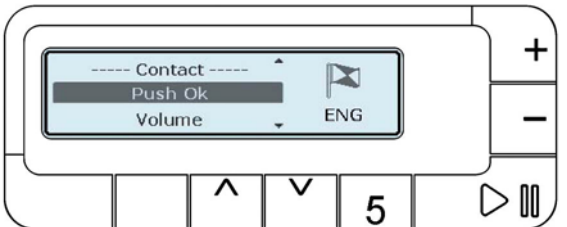
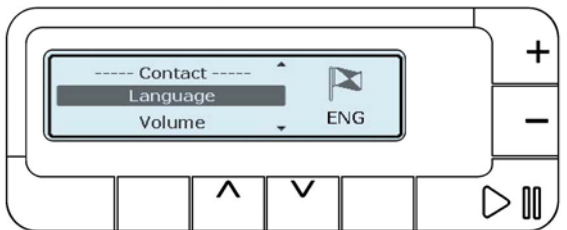

Waiting some seconds or pushing buttons: TEMPERATURE (1) or SPIN (2) the main screen is displayed again.

Pushing button OK (5) the language is selected again.

Pushing button START/PAUSE (6) the washing cycle starts.

To access rapidly to the language modification: hold down buttons 1 and 2 simultaneously for five seconds.

4.2.12.2 Volume

Push button **3** or **4** and scroll down the menu till:

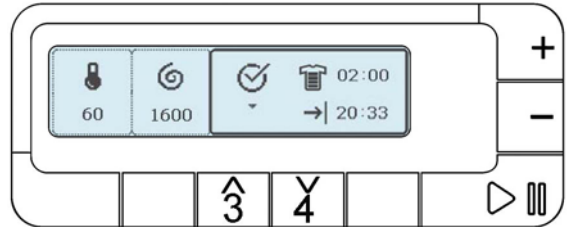

“SETTINGS”

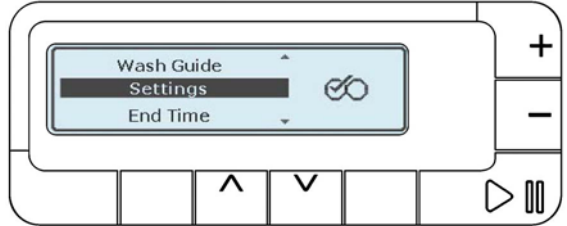

Wait two seconds the writing changes to:
“PUSH OK” button **5**.

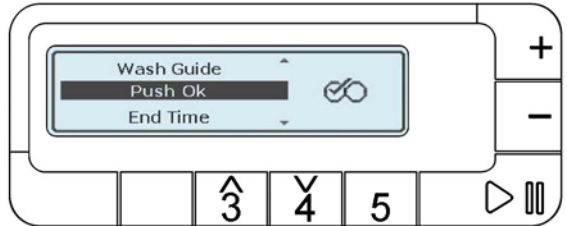

Push button **3** or **4** and scroll down the menu till:

“VOLUME”

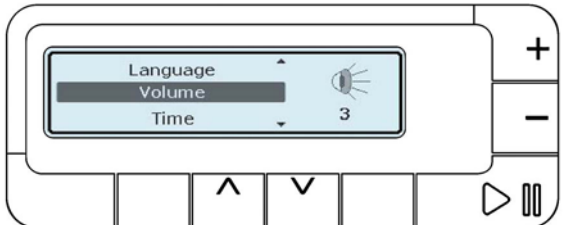

Push button OK (5).

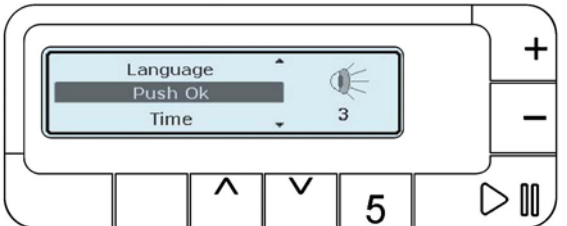

The digit under the loudspeaker symbol starts to flash. Now it is possible to vary the volume level pushing buttons **3** or **4** in sequence (at every variation the sound is activated to represent the reached level and the digit changes from zero to nine). To confirm the choice, push button OK (5).

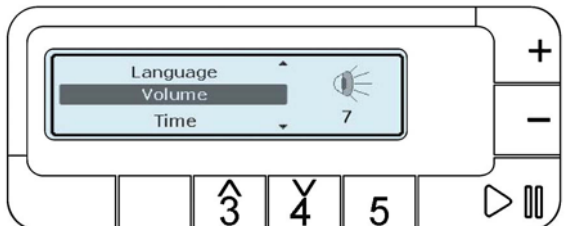

Waiting some seconds or pushing buttons: TEMPERATURE (1) or SPIN (2) the main screen is displayed again.

Pushing button OK (5) the volume is selected again.

Pushing button START/PAUSE (6) the washing cycle starts.

SOUND

The appliance features three types of melodies (one for the switching on, one for the programme start and one for the end of the washing cycle) and a series of beeps in case of alarm.

- ↻ Every time the appliance is switched on (programme start).
- ↻ When the appliance is switched off and then on again it does not emit a sound (programme started).
- ↻ At the end of the cycle with decreasing frequency (for about three minutes).
- ↻ During the alarms the sound is repeated for about five minutes (series of beeps).
- ↻ No sound is emitted during the rotation of the selector knob, or when a button is pressed.
- ↻ To activate the sound it is necessary to regulate the volume at zero level.

4.2.12.3 Time

Push button **3** or **4** and scroll down the menu till:

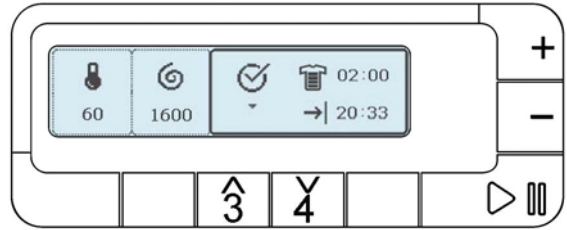

“SETTINGS”

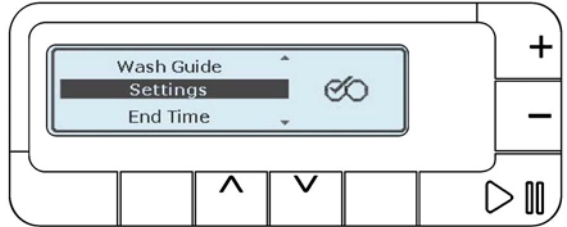

Wait two seconds the writing changes to:
“PUSH OK” button **5**.

Push button **3** or **4** and scroll down the menu till:

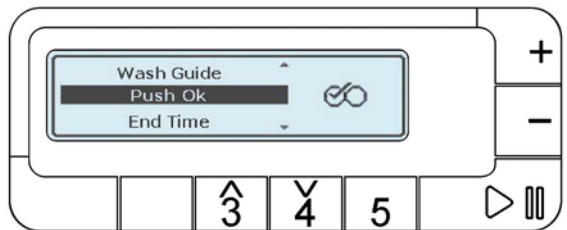

“TIME”

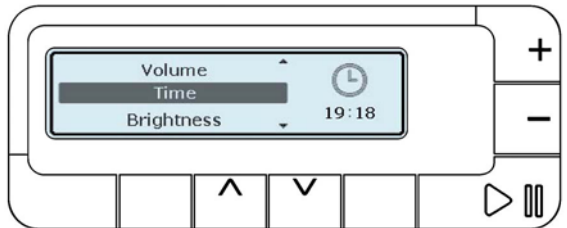

Push button OK (5).

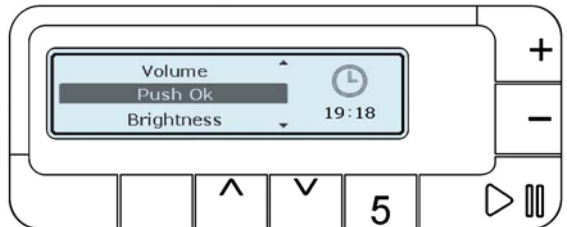

The digits under the clock symbol start to flash. Now it is possible to insert the day time pushing buttons **3** or **4** in sequence. To confirm push button OK (5).

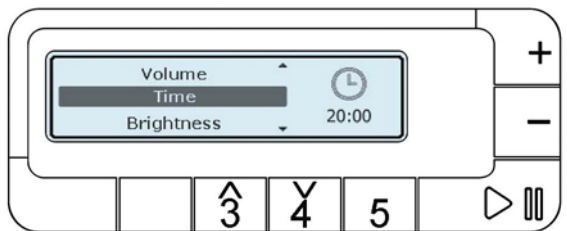

Waiting some seconds or pushing buttons: TEMPERATURE (1) or SPIN (2) the main screen is displayed again.

Pushing button OK (5) the time is selected again.

Pushing button START/PAUSE (6) the washing cycle starts.

4.2.12.4 Luminosity

Push button **3** or **4** and scroll down the menu till:

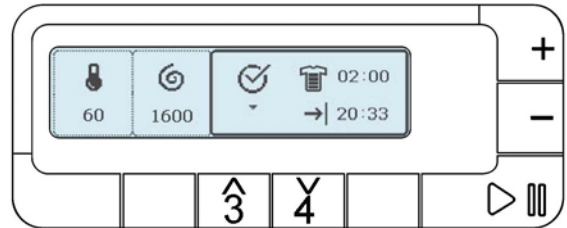

“SETTINGS”

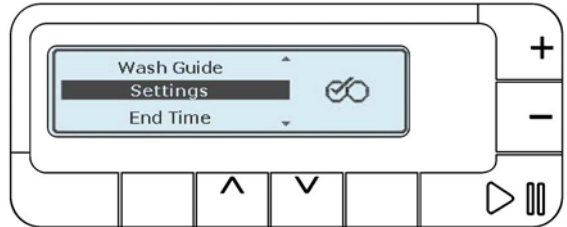

Wait two seconds the writing changes to:
“PUSH OK” button **5**.

Push button **3** or **4** and scroll down the menu till:

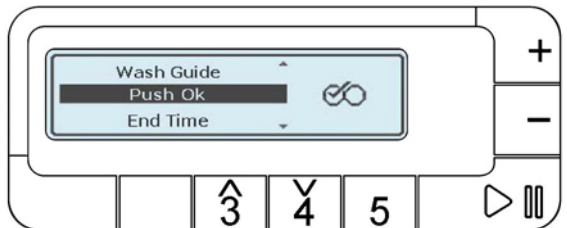

“LUMINOSITY”

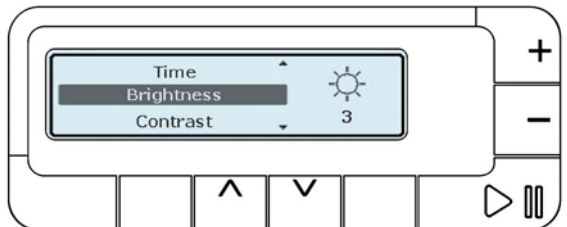

Push button OK (5).

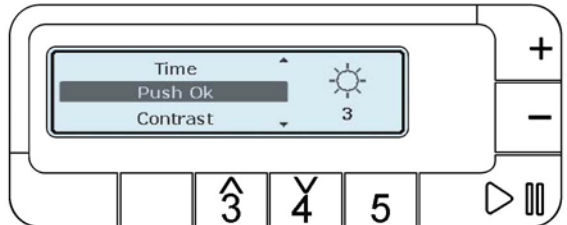

The digit under the sun symbol starts to flash. Now it is possible to vary the luminosity level pushing buttons **3** or **4** in sequence. Simultaneously, the LCD display varies and also the digit changes from zero to nine. Confirm the luminosity level with button OK (5).

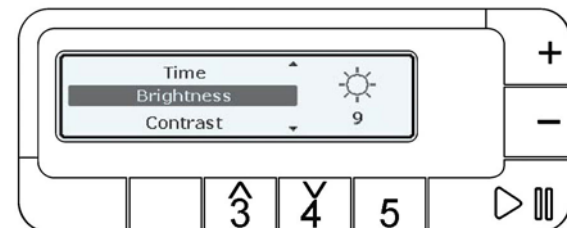

Waiting some seconds or pushing buttons: TEMPERATURE (1) or SPIN (2) the main screen is displayed again.

Pushing button OK (5) the luminosity is selected again.

Pushing button START/PAUSE (6) the washing cycle starts.

4.2.12.5 Contrast

Push button **3** or **4** and scroll down the menu till:

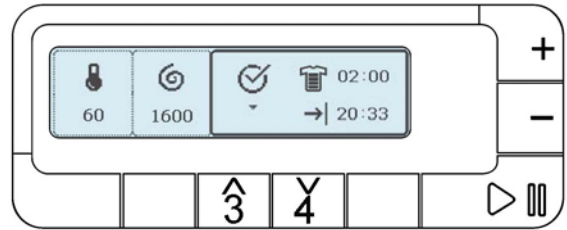

“SETTINGS”

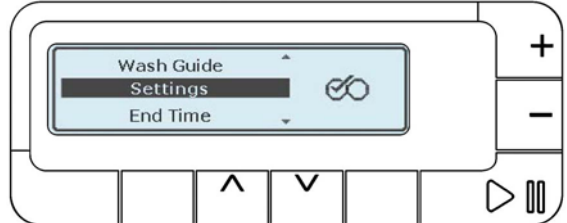

Wait two seconds the writing changes to:
“PUSH OK” button **5**.

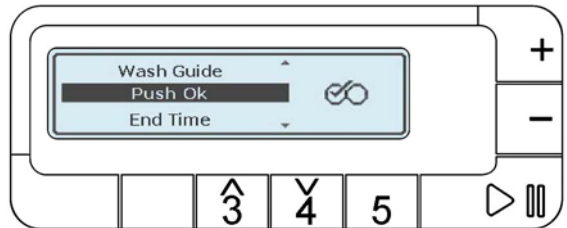

Push button **3** or **4** and scroll down the menu till:

“CONTRAST”

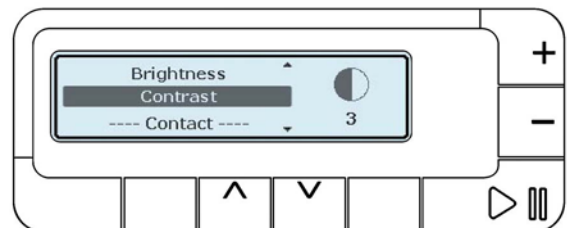

Push button OK (5).

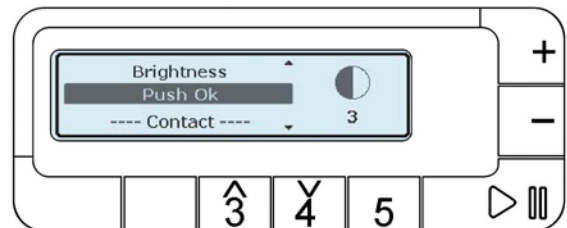

The digit under the symbol starts to flash. Now it is possible to vary the contrast level pushing buttons **3** or **4** in sequence. Simultaneously, the LCD display varies and also the digit changes from zero to nine. Confirm the contrast level with button OK (5).

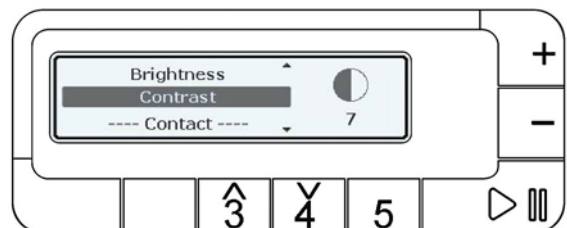

Waiting some seconds or pushing buttons: TEMPERATURE (1) or SPIN (2) the main screen is displayed again.

Pushing button OK (5) the contrast is selected again.

Pushing button START/PAUSE (6) the washing cycle starts.

4.2.12.6 Resetting the settings

This function allows the user to reset the basic settings set by the factory for: VOLUME, CONTRAST, LUMINOSITY and the configuration of the CHILD LOCK.

Push button **3** or **4** and scroll down the menu till:

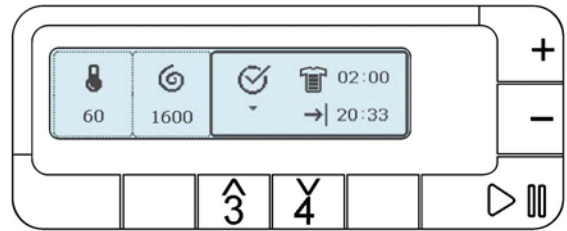

“SETTINGS”

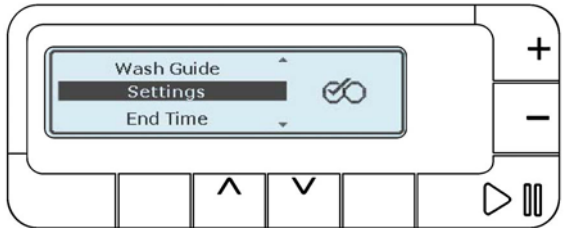

Wait two seconds the writing changes to:
“PUSH OK” button **5**.

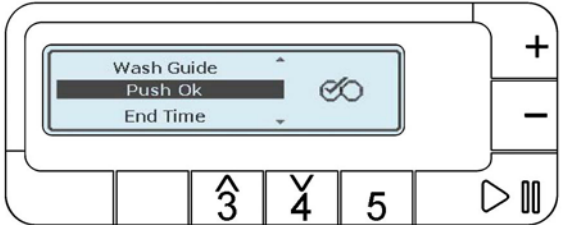

Push button **3** or **4** and scroll down the menu till:

“RESET SETTINGS”

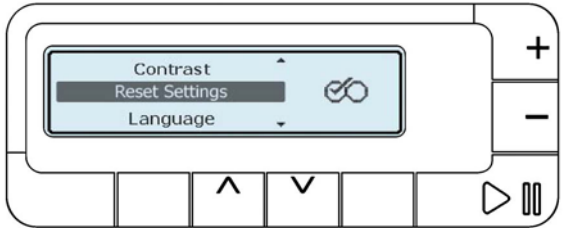

Wait two seconds the writing changes to:
“PUSH OK” button **5**.

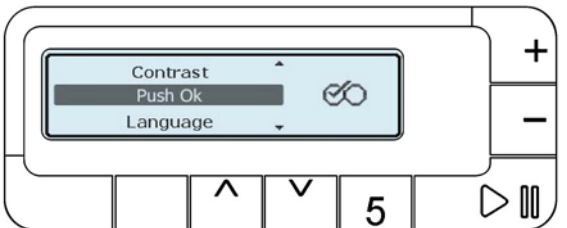

After pushing OK the user is asked to confirm the choice. It is possible to confirm pushing OK (**5**) or to cancel with buttons **3** or **4**.

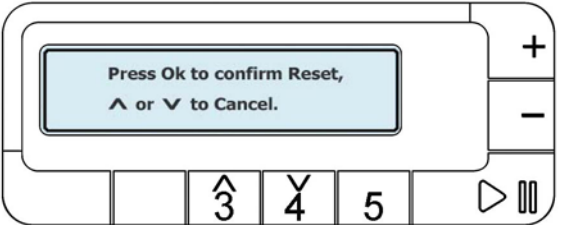

If the choice is confirmed, the LCD display shows this screen for two seconds.



4.2.12.7 Delayed start

To modify the time to end of the cycle indicated in the right lower side it is necessary:

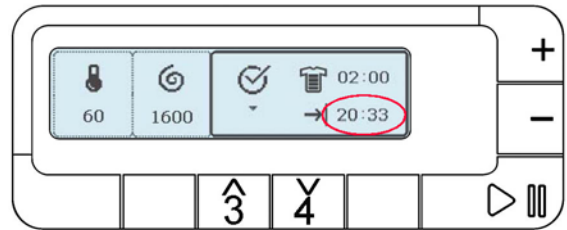

Push buttons **3** or **4** and scroll down the menu till: "END TIME".

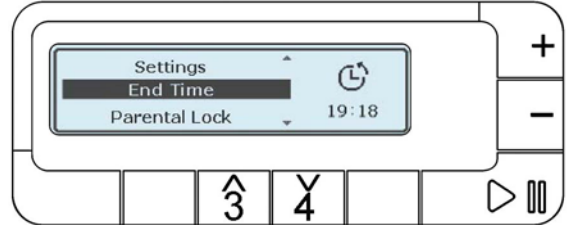

Push OK button **5** the four digits which indicate the time start to flash.

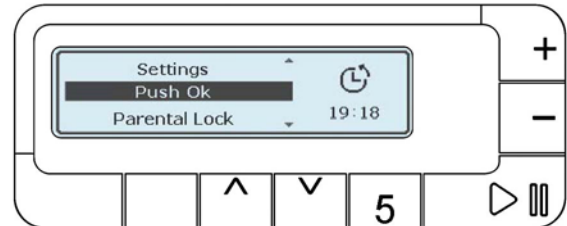

It is possible to modify the time with buttons 3 or 4. Pushing it in sequence the time increases or decreases (respectively with button 3 and 4) by thirty minutes for the first two hours and sixty minutes till the twenty hours are reached (the max. time available for the delayed start).

Holding down the button, the variation accelerates.

To cancel the time of the delayed start just reset the set time.

Set the time, push OK button **5**.

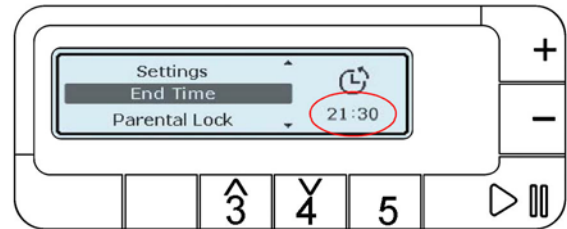

The main screen with the chosen options and the time to end appears again.

To start the washing cycle push button **6**.

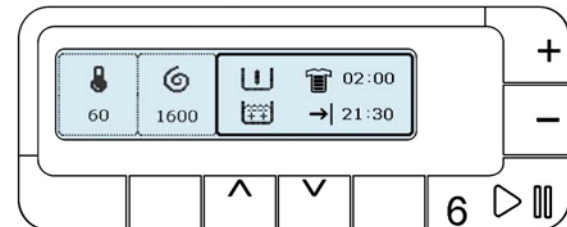

"START DELAYED" appears.

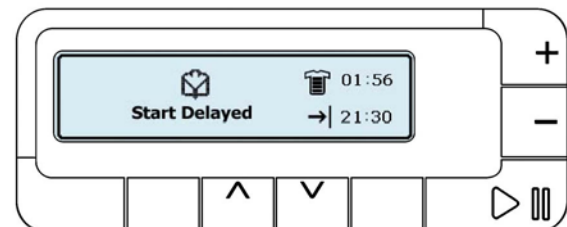

Once the set delayed time has elapsed, the appliance starts the washing cycle.

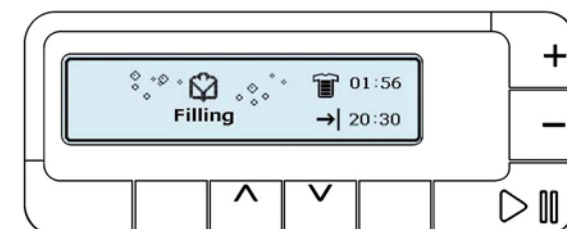

5 DIAGNOSTIC SYSTEM

5.1 Access to diagnostic mode

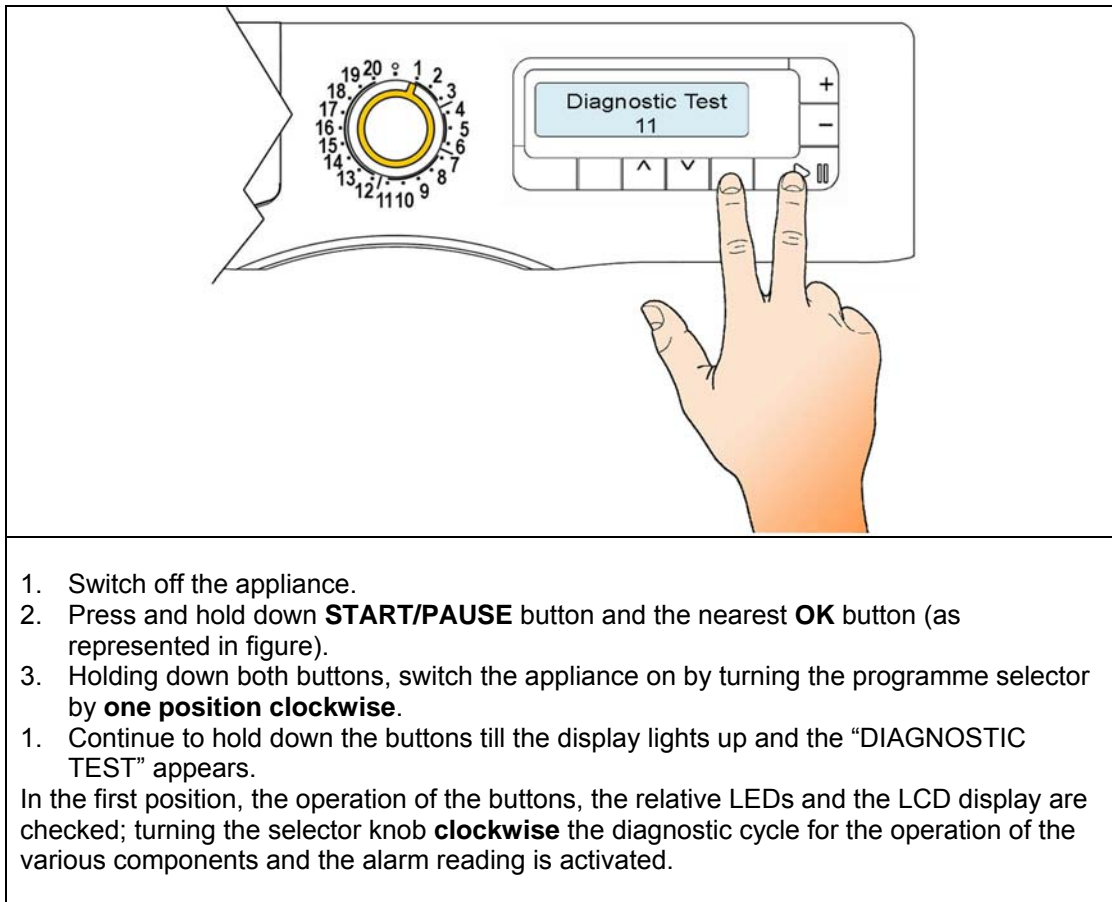

5.2 Exiting diagnostic mode









→ To exit the diagnostic cycle, switch the appliance off, then on, and then off again.

When the appliance is switched on again, it is necessary to set the time and language.

5.3 Diagnostic phases

Irrespective of the type of PCB and the configuration of the programme selector it is possible, after entering diagnostic mode, to perform diagnostics on the operation of the various components and to read the alarms by turning the programme selector **clockwise**.

All the alarms are enabled during the diagnostic cycle.

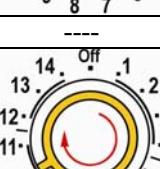
Selector position	Components actioned	Operating conditions	Function checked	Display
1	 <ul style="list-style-type: none"> - All the LEDs and symbols light in sequence. - When a button is pressed, the LCD display shows the code 	Always activated	Operation of the user interface	
2	 <ul style="list-style-type: none"> - Door interlock - Wash solenoid 	Door locked Water level below anti-flooding level Maximum time 5 minutes	Water ducted through washing compartment	Displays the water level in tub
3	 <ul style="list-style-type: none"> - Door interlock - Pre-wash solenoid 	Door locked Water level below anti-flooding level Maximum time 5 minutes	Water ducted through pre-wash compartment (bleach)	Displays the water level in tub
4	 <ul style="list-style-type: none"> - Door interlock - Pre-wash and wash solenoids 	Door locked Water level below anti-flooding level Maximum time 5 minutes	Water ducted through conditioner compartment	Displays the water level in tub
5	 <ul style="list-style-type: none"> - Door interlock - Bleach/stains solenoids 	Door locked Water level below anti-flooding level Maximum time 5 minutes	Water ducted through conditioner/stains compartments	Displays the water level in tub
6	 <ul style="list-style-type: none"> - Door interlock - Wash solenoid if the level of water in the tub does not cover the heater - Heating element - Recirculation pump 	Door locked Water level above the heater Maximum time 10 minutes or up to 90°C (*)	Heating Recirculation	Wash water temperature
7	 <ul style="list-style-type: none"> - Door interlock - Wash solenoid if the level of water in the tub does not cover the heater - Motor (55 rpm clockwise, 55 rpm counter-clockwise, 250 rpm impulse) 	Door locked Water level above the heater	Check for leaks from the tub	Displays the drum speed (the real value divided by ten)
8	 <ul style="list-style-type: none"> - Door interlock - Drain pump - Motor up to 650 rpm then at maximum spin speed 	Door locked Water level lower than anti-boiling level for spinning	Drain and spin; control of congruence in closure of level pressure switches	Displays the drum speed (the real value divided by ten)
9	----	----	----	----
10	 <ul style="list-style-type: none"> - Reading/Cancellation of the last alarm 	----	----	----

(*) In most cases, this time is sufficient to check the heating. However, the time can be increased by repeating the phase without draining the water: pass for a moment to a different phase of the diagnostic cycle and then back to the heating control phase (if the temperature is higher than 80°C, heating does not take place).

(**) The check at the maximum speed occurs without control of the FUCS and no clothes have to be inserted inside the appliance.

5.3.1 Analysis of the LCD display during the diagnostic cycle

In position 1 the LCD display is displayed through the chessboard lighting (with different dimensions) of all the display points. Every time that during this test a button is pushed the test is interrupted and in the bottom centre the button codification is shown.

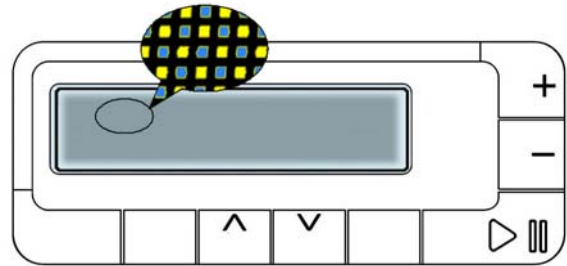

From position 2 to position 9 the display represents:

The temperature on the left lower side.
The drum speed in the centre.
The water level on the right.

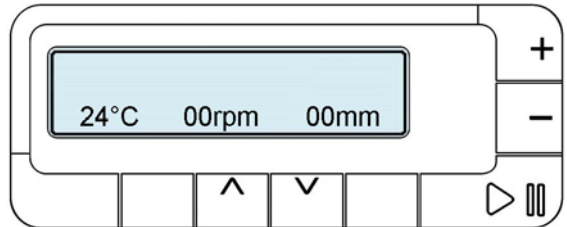

In position 10 the reading alarm is shown.

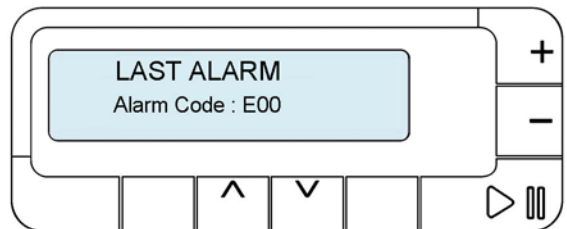

6 ALARMS

6.1 Displaying the alarms to the user

The alarms are displayed by the red LED of the START/PAUSE button flashing and simultaneously through the LCD.

The alarms displayed to the user are listed below:

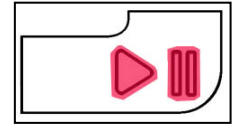

↪ E10 - Water fill difficulty (closed tap)

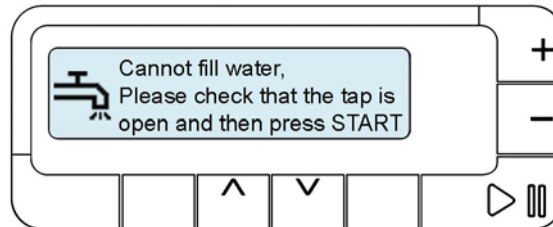

↪ E20 - Drain difficulty (dirty filter)

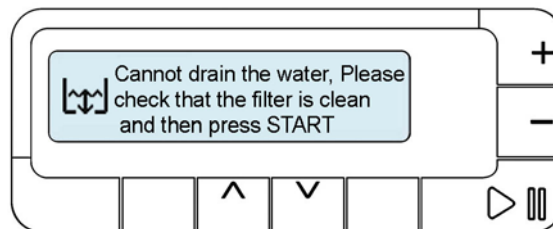

↪ E40 - Door open

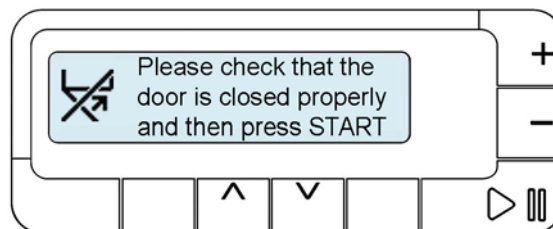

They can be solved directly by the end user;

While the alarms listed below:

↪ EF0 - Water leakage (Aqua Control System)

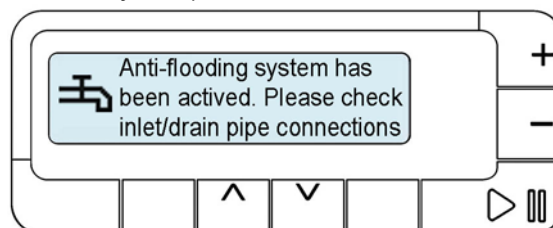

↪ EH0 - Voltage or frequency out of the normal values

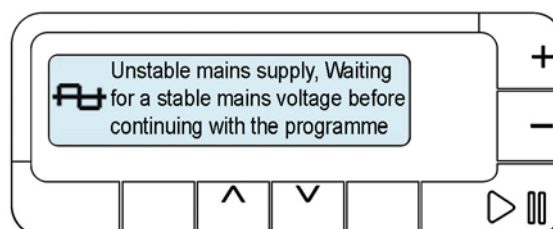

They are displayed to the user, but for their solution it is necessary the intervention of the Service.

The alarms are enabled during the execution of the washing programme, with the exception of alarms associated with configuration and the power supply (voltage/frequency), which are also displayed during the programme selection phase.

The door can normally be opened (except where specified) when an alarm condition has occurred on condition that:

- The level of the water in the tub is below a certain level
- Water temperature lower than 55°C
- Motor stopped

Certain alarm conditions require that a drain phase be performed before the door can be opened for safety reasons:

- Cooling water fill if the temperature is higher than 65°C
- Drain until the analogue pressure switch is on empty, during a max. 3-minute time.

6.2 Reading the alarm codes

It is possible to display the last three memorised alarms in the FLASH memory of the electronic board:

- Enter diagnostic mode (par. 5.1).
- Irrespective of the type of PCB and configuration, turn the programme selector **clockwise** to the **tenth position**.

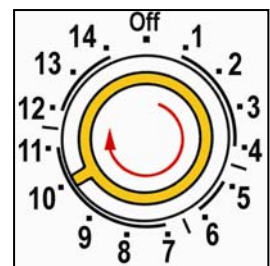

- The last alarm is displayed.

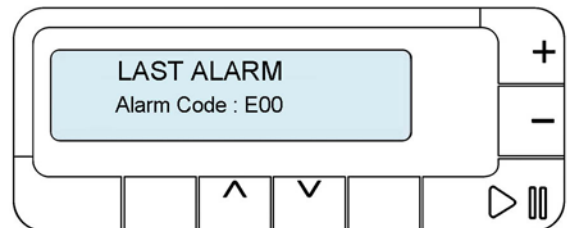

- To display the previous alarms, press button TEMPERATURE (1) or SPIN (2).

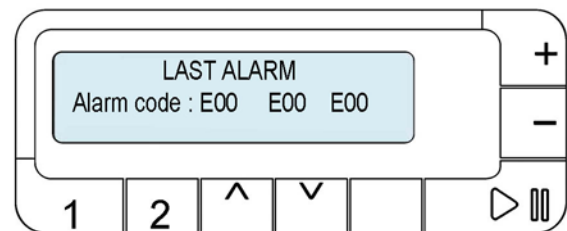

6.2.1 Displaying the alarm

The alarm is displayed by a repeated flashing sequence of the START / PAUSE button with red and green light (0,5 seconds on, 0,5 seconds off with a 2,5 second pause between the sequences).

- button indicator START / PAUSE with red light → indicates the first digit of the alarm code (family)
- button indicator START / PAUSE with green light → indicates the second digit of the alarm code (internal number of the family)

These two LEDs are featured in all models.

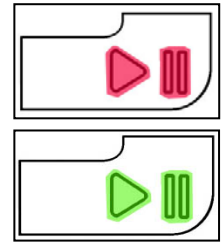

Notes:

- The first letter of the alarm code "E" (Error) is not displayed, since this letter is common to all alarm codes.
- The alarm code "families" are shown in hexadecimal; in other words:
 - **A** is represented by **10** flashes
 - **B** is represented by **11** flashes
 - ...
 - **F** is represented by **15** flashes
- Configuration errors are shown by the flashing of all the LEDs (user interface not configured).

6.2.2 Examples of alarm display

Example: Alarm E43 (problems with the door interlock Triac) will display the following:

- the sequence of four flashes of the START / PAUSE button with red light, indicates the first number **E43**;
- the sequence of three flashes of the START / PAUSE button with green light, indicates the second number **E43**;

START / PAUSE button with red light			START / PAUSE button with green light		
ON / OFF	Time (Sec.)	Value	ON / OFF	Time (Sec.)	Value
	0.5	1		0.5	1
	0.5			0.5	
	0.5	2		0.5	2
	0.5			0.5	
	0.5	3		0.5	3
	0.5			0.5	
	0.5	4		2.5	Pause
	0.5				
	1.5	Pause			

6.2.3 Operation of alarms during diagnostics

All alarms are enabled during the components diagnostic phase.

6.3 Rapid reading of alarm codes

The last three alarm codes can be displayed even if the programme selector is not in the tenth position (diagnostics) or if the appliance is in normal operating mode (e.g. during the execution of the washing programme):

- Press and hold down **START/PAUSE** and the **OK** button (as to enter the DIAGNOSTICS), for at least two seconds: the display shows directly a screen with all the alarms.
- To return to the main screen press any button.
- The alarm reading system is as described in paragraph 6.2.
- While the alarms are displayed, the appliance continues to perform the cycle or, if in the programme selection phase, maintains the previously-selected options in memory.

6.4 Cancelling the last alarm

It is good practice to cancel the last alarm:

- after reading the alarm code, to check whether the alarm re-occurs during diagnostics;
- after repairing the appliance, to check whether it re-occurs during testing.

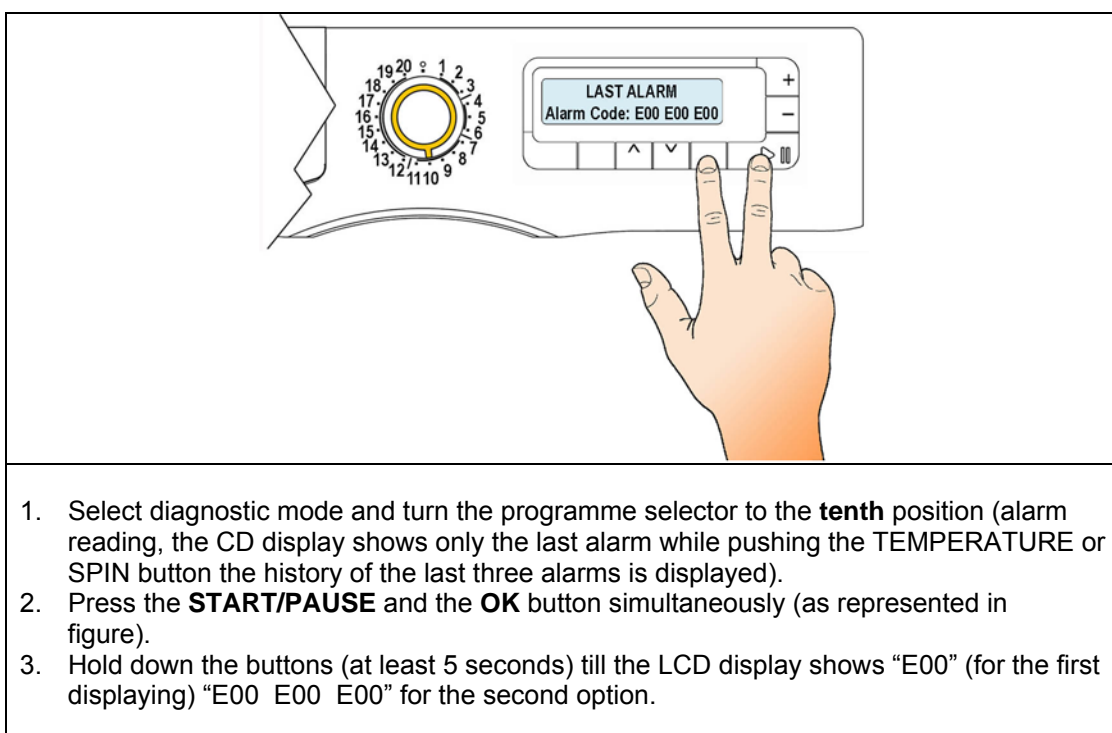

N.B. With this operation all the memorised alarms are deleted.

6.5 Cancelling the memories

To cancel the content of the memories, proceed as follows:

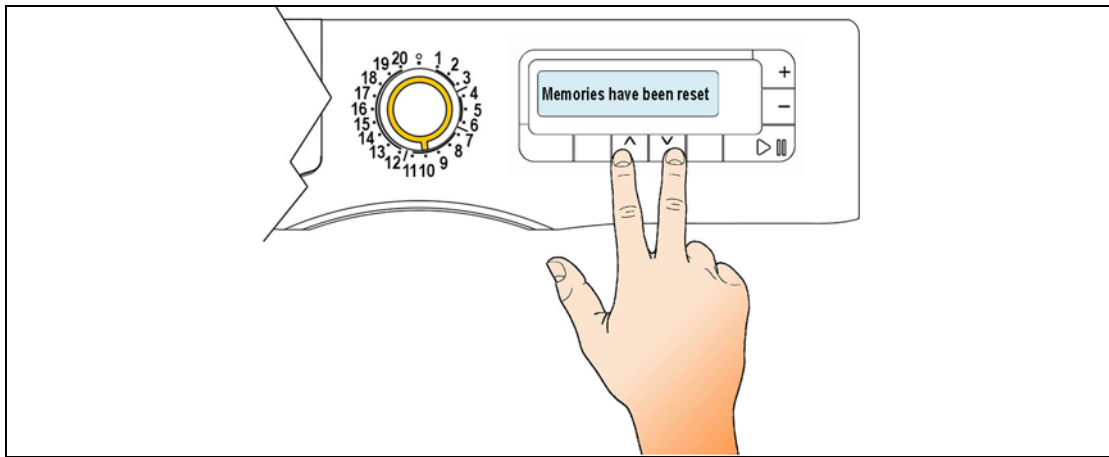

1. Select diagnostic mode and turn the programme selector to the **tenth** position.
2. Push the OPTIONS 3 and 4 button (as represented in figure).
3. Hold down the buttons till the LCD display shows "Memories have been reset" (at least 5 seconds).

7 OPERATING TIME COUNTER

Using a specific procedure, the operator can display the total operating time for the appliance, which is counted from the moment it is first switched on.

This option is available only on models equipped with a display. The unit can count up to a maximum of **6550** hours of operating time.

- Only the operating time of normal programmes (and not diagnostic programmes) is counted
- The actual operating time for the cycle is counted (which does not include pauses, delayed start time, time of a stop with water in the drum, and soaking phases)
- The precision of the counter is 30 seconds per programme
- Only whole hours of operation are counted (1 hr and 59 min = 1 hr)

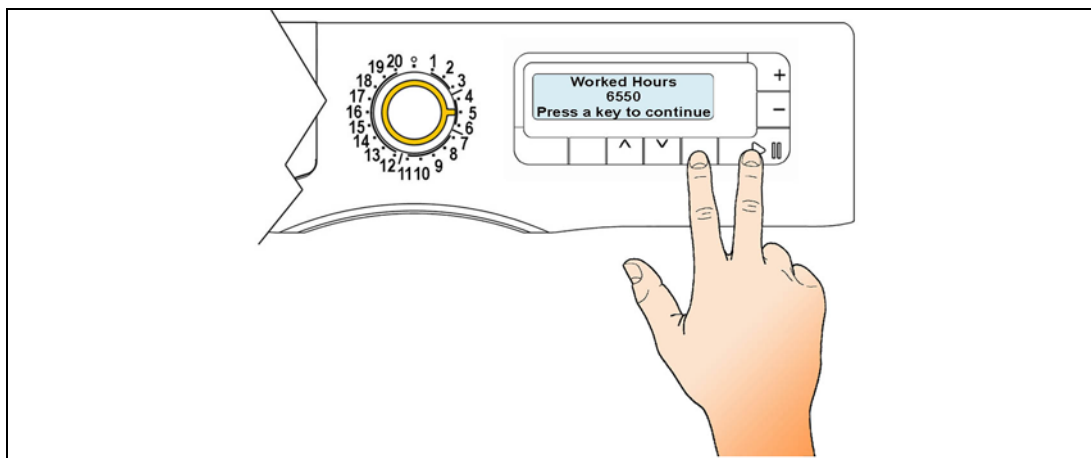

1. Switch off the appliance.
2. Press the **START/PAUSE** and the **OK** button simultaneously (as represented in figure).
3. Holding the buttons down, switch on the appliance turning the programme selector of **five positions clockwise**.
4. Hold the buttons down till the LCD shows "WORKED HOURS" (at least 5 seconds) and the display shows the number of the working hours of the appliance.

8 WASHING PROGRAMMES AND OPTIONS

8.1 Programmes

The washing programmes can be configured. The basic programmes are listed in the table below.

Programme		Temperature (°C)	Number of rinses	Final spin (rpm)
Cotton	90	82	3	450/650/850/1000/1200/ 1300/1400/1600
	90E	67(*)	(**)	
	60	60	3	
	60E	55 (*)	(**)	
	50	50	3	
	50/40E	44(*)	(**)	
	40	40	3	
	30	30		
	cold	20		
Synthetic fabrics	60	60	3	Max. 900
	60/50E	42(*)	(**)	
	50	50	3	
	40	42		
	30	30		
cold	20			
Mini Programme	30	30	3	Max. 900
	cold	20		
Delicates	40	40	3	450/700
	30	30		
	cold	20		
Wool Hand-wash	40	38	3	Max. 1000
	30	33		
	cold	20		
Shoes	40	40	3	Max. 1000
	30	30		
	cold	20		
Jeans	60	60	5	450/650/850/1000/1200/ 1300/1400/1600
	50	50		
	40	40		
	30	30		
	cold	20		
Soak		30/20	----	----
Rinses		----	3	Max. 1600
Conditioner		----	1	Max. 1600
Drain		----	----	----
Spin		----	----	Max. 1600

The data are indicative.

(*) "Energy label" programmes

(**) In some countries the rinses are 3, in others 2

8.2 Options

The table below lists the possible options for the washing programmes, the compatibility of the various options and with the cycle, and when it is possible to select or modify the options.

The options can be selected in three ways:

- using the programme selector: in this case, the options are configured as special programmes;
- using the pushbuttons.

		OPTIONS																
		Rinse-hold	Night cycle	Pre-wash	Stains	Bleach	Extra rinse	Easy-iron	Economy (*)	Intensive	Normal	Daily	Light	Quick	Super Quick	Reduced spin speed	No spin	Half-load
Compatibility with PROGRAMMES	Cotton	90°C	X	X	X	X	X	X	X	X	X	X	X	X	X	X	X	X
		60°C	X	X	X	X	X	X	X	X	X	X	X	X	X	X	X	X
		50°C	X	X	X	X	X	X	X	X	X	X	X	X	X	X	X	X
		40°C	X	X	X	X	X	X	X	X	X	X	X	X	X	X	X	X
		30°C	X	X	X		X	X	X		X	X	X	X	X	X	X	X
	cold	X	X	X		X	X	X		X	X	X	X	X	X	X	X	X
	Synthetic fabrics	60°C	X	X	X	X		X	X	X		X	X	X		X	X	X
		50°C	X	X	X	X		X	X	X		X	X	X		X	X	X
		40°C	X	X	X	X		X	X	X		X	X	X		X	X	X
		30°C	X	X	X			X	X			X	X	X		X	X	X
		cold	X	X	X			X	X			X	X	X		X	X	X
	Delicates	40°C	X	X	X	X		X				X	X	X		X	X	X
		30°C	X	X	X			X				X	X	X		X	X	X
		cold	X	X	X			X				X	X	X		X	X	X
	Wool / Hand-wash	40°C	X	X												X		
		30°C	X	X												X		
		cold	X	X	X											X		
	Easy-iron	60°C	X		X			X	X			X				X	X	
		50°C	X		X			X	X			X				X	X	
		40°C	X		X			X	X			X				X	X	
		30°C	X		X			X	X			X				X	X	
		cold	X		X			X	X			X				X	X	
	Duvet	40°C										X				X		
		30°C										X				X		
	Jeans	60°C	X	X	X			X	X			X				X	X	
		50°C	X	X	X			X	X			X				X	X	
		40°C	X	X	X			X	X			X				X	X	
		30°C	X	X	X			X	X			X				X	X	
		cold	X	X	X			X	X			X				X	X	
	Shoes	40°C	X	X	X			X				X				X		
		30°C	X	X	X			X				X				X		
		cold	X	X	X			X				X				X		
	Lingerie	40°C	X	X												X	X	
30°C		X	X												X	X		
cold		X	X												X	X		
Silk	30°C	X	X											X	X	X		
	cold	X	X											X	X	X		
Baby	40°C	X	X	X			X				X				X	X		
	30°C	X	X	X			X				X				X	X		
	cold	X	X	X			X				X				X	X		
Mini, Flash, Sport, Light	30°C													X	X	X		
Hygienize	90°C	X	X	X	X	X	X			X					X	X		

(*) Economy

➤ Cotton: 90°C = Eco 67°C; 60°C = Energy Label; 50°-40°C = Eco 40° C AA

➤ Synthetics: 60-60°C= Eco 40°C

X Option included in the programme and cannot be deleted

		OPTIONS																	
		Rinse-hold	Night cycle	Pre-wash	Stains	Bleach	Extra rinse	Easy-iron	Economy (*)	Intensive	Normal	Daily	Light	Quick	Super Quick	Reduced spin speed	No spin	Half-load	
Compatibility with PROGRAMMES	Sport	40°C	X	X	X			X				X					X	X	
		30°C	X	X	X			X				X					X	X	
		cold	X	X	X			X				X					X	X	
	Shirts	30°C													X	X			
	Mixed°	40°C	X	X	X	X	X		X							X	X	X	
	Hygienize	90°C	X	X		X		X	X			X					X	X	X
		60°C	X	X		X		X	X			X					X	X	X
		50°C	X	X		X		X	X			X					X	X	X
		40°C	X	X		X		X	X			X					X	X	X
	Grass	60°C	X	X	X	X		X	X		X						X	X	
		50°C	X	X	X	X		X	X		X						X	X	
		40°C	X	X	X	X		X	X		X						X	X	
	Express	60°C	X					X								X	X		
	Sensitive plus	90°C	X	X	X	X	X	X		X	X	X	X	X	X	X	X	X	
		60°C	X	X	X	X	X	X		X	X	X	X	X	X	X	X	X	
		50°C	X	X	X	X	X	X		X	X	X	X	X	X	X	X	X	
		40°C	X	X	X	X	X	X		X	X	X	X	X	X	X	X	X	
		30°C	X	X	X		X	X		X	X	X	X	X	X	X	X	X	
		cold	X	X	X		X	X		X	X	X	X	X	X	X	X	X	
	Rapid	30°C	X					X									X		
	Viscose	40°C	X	X		X		X		X							X	X	X
		30°C	X	X		X		X		X							X	X	X
		cold	X	X		X		X		X							X	X	X
	Soak	30°C			X														
	Rinses			X			X	X	X								X	X	
	Delicates Rinses			X				X									X	X	
	Conditioner			X					X								X	X	
	Delicate conditioner			X					X								X	X	
Drain																			
Spin																X			
Delicate spin																X			

(*) Economy

➤ Cotton: 90°C = Eco 67°C; 60°C = Energy Label; 50°= Eco 48°C;40°C = Eco 44°C AA

➤ Synthetics: 60-60°C = Eco 40°C

X	Option included in the programme and cannot be deleted
X	Only for JETSYSTEM+FLOWMETER

8.2.1 Compatibility between Options

		OPTIONS																
		Rinse-hold	Night cycle	Pre-wash	Stains	Bleach	Extra rinse	Easy-iron	Economy (*)	Intensive	Normal	Daily	Light	Super Quick	Reduced spin speed	No spin	Half-load	Rinse-hold
Compatibility with OPTIONS	Rinse-hold			X	X	X	X	X	X	X	X	X	X	X	X			X
	Night cycle			X	X	X	X		X	X	X	X	X	X	X			X
	Pre-wash	X	X		(*)	(*)	X	X	X	X	X	X	X	X	X	X	X	X
	Stains	X	X	(*)		(*)	X	X	X	X	X	X	X	X	X	X	X	X
	Bleach	X	X	(*)	(*)		X	X	X	X	X	X	X	X	X	X	X	
	Super rinse	X	X	X	X	X		X	X	X	X	X	X	X	X	X	X	X
	Easy-iron	X		X	X	X	X		X	X	X	X	X	X	X	X	X	X
	Economy	X	X	X	X	X	X										X	X
	Intensive	X	X	X	X	X	X										X	X
	Normal	X	X	X	X	X	X										X	X
	Daily	X	X	X	X	X	X										X	X
	Light	X	X	X	X	X	X										X	X
	Quick	X	X	X	X	X	X										X	X
	Super Quick	X	X	X	X	X	X										X	X
	Reduced spin speed			X	X	X	X	X	X	X	X	X	X	X	X	X		X
	No spin			X	X	X	X	X	X	X	X	X	X	X	X	X		X
Half-load	X	X	X	X		X	X	X	X	X	X					X	X	
Phases in which selection or modification are possible	Selection	X	X	X	X	X	X	X	X	X	X	X	X	X	X	X	X	
	Pre-wash	X	X		X	X	X									X	X	
	Wash	X	X		X	X	X									X	X	
	Rinses	X	X															
	Spin																	

- (*) Prewash, Stains and Bleach are compatible depending on which detergent drawer is used.
- The delayed start is compatible with all programmes, the max. time that can be selected is 20 hours.
 - The spin selection is available for all programmes except for the drain.

The table below shows other limitations in the compatibility of the options due to the drawer type and electric valve number.

	3C-2V	4C-2V	4C-3V	4C-3V
BLEACHING	◇	▶	◆	◇
PREWASH / SOAK	▶	▶	▶	◆
STAINS	▶	▶	▶	◆

4C= 4-compartment drawer
 3C= 3-compartment drawer
 3V= 3 electric valves
 2V= 2 electric valves

◇ = Option not available
 ◆ = Option available
 ▶ = Only one of these options can be selected

8.3 Description of options

- **Rinse-hold**

- Stops the appliance with water in the tub before the final spin cycle.
- To drain the water, reset the programme and then select a drain or spin cycle.

- **Night cycle**

- Eliminates all spin phases and adds **three** rinses in COTTON cycles and **two** rinses in SYNTHETICS cycles.
- Stops the appliance with water in the tub before the final rinse.
- Eliminates the buzzer (if configured)
- To drain the water, reset the programme and then select a drain or spin cycle.

- **Pre-wash**

- Adds a pre-wash phase at the start of the cycle with water heating to 30°C (or cold, if selected).
- In COTTON and SYNTHETICS cycles, performs a short spin before passing to the washing phase.
- This option cannot be selected for WOOL and HAND-WASH cycles.

- **Soak**

- Adds a pre-wash phase (with duration of 30' with wool cycle movement) at the start of the cycle with water heating to 30°C (or cold, if selected).
- In COTTON and SYNTHETICS cycles, performs a short spin before passing to the washing phase.
- Together with the delayed start option it is possible to select a soak time from 30min to 10 hours.
- This option cannot be selected for WOOL and HAND-WASH cycles.

- **Stains**

- Adds a 5-minute motor movement phase after heating to 40°C.
- Ducts water to the pre-wash/stains compartment in order to introduce the special stain-removal product.
- This option cannot be selected for DELICATES, WOOL and HAND-WASH cycles.

- **Bleach**

- Ducts water through the bleach compartment at the beginning of the first rinse in COTTON cycles.

- **Economy / Energy label**

- Modifies the structure of the COTTON 40-60 and SYNTHETICS 50/60 programmes in order to reduce energy consumption.
- Reduces the washing temperature.
- Increases the duration of the wash phase.

- **Super-rinse**

- Adds **two** rinses in the COTTON, SYNTHETICS and DELICATES cycles.
- Eliminates the intermediate spin cycles, with the exception of the final rinse, which is reduced to 450 rpm.

- **Half-load**

- Eliminates one rinse in COTTON programmes.

- **Easy-Iron**

- In COTTON programmes:
 - adds **three** rinse cycles
 - eliminates the intermediate spin cycles
 - performs an impulse spin phase
 - adds an "untangling" phase after the spin cycle
- In SYNTHETICS cycles:
 - reduces the heating temperature in 50/60° cycles to 40°C
 - increases the washing time
 - prolongs the cooling phase at the end of the washing phase
 - adds **one** rinse
 - adds an "untangling" phase after the impulse spin cycle

- **Reduced spin speed**

→ Reduces the speed of **all** spins as shown in the table.

Maximum spin speed (rpm)	600	700	800	900	1000	1100	1200	1300	1400	1550
Reduction for COTTON (rpm)	450	450	450	450	500	550	600	650	700	750
Reduction for ALL OTHER CYCLES (rpm)	450	450	450	450	450	450	450	450	450	450

- **No spin**

→ Eliminates **all** the spin phases.

→ If selected, three rinses are added in the COTTON cycle and one in the SYNTHETICS cycle.

- **Intensive**

→ Performs a specific intensive cycle.

- **Daily**

→ Modifies the structure of the COTTON - SYNTHETICS - DELICATES cycles to obtain a good washing performance with a short time.

- **Light**

→ Modifies the structure of the wash phase of the COTTON - SYNTHETICS - DELICATES cycles in a short time.

- **Short**

→ Modifies the structure of the COTTON - SYNTHETICS - DELICATES cycles to obtain very short washing times (optimized for reduced wash loads and very dirty).

→ Reduces the number of rinses (one rinse less).

→ Increases the water level of the other two rinses.

- **Very short**

→ Modifies the structure of the wash phase of the COTTON - SYNTHETICS - DELICATES cycles for half load.

9 TECHNICAL CHARACTERISTICS

9.1 Control system memory



9.1.1 General structure of the memory system

The system features an EEPROM memory module, fitted externally to the microprocessor, which serves to memorize the configuration data, the description of the cycle, the status of the appliance in the event of a power failure, and the alarms.

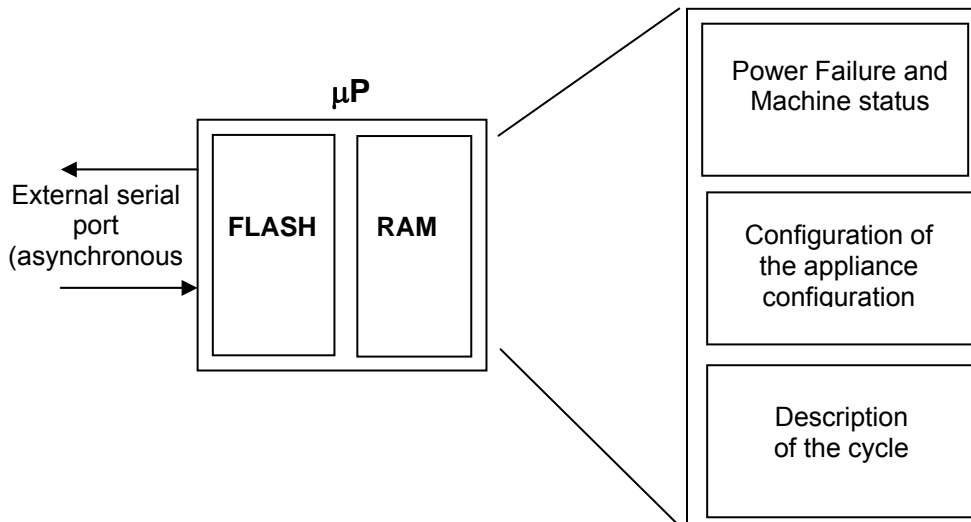

9.1.2 FLASH

This area memory contains the firmware code relative to the functions of the appliance:

- ⇒ Control of electrical loads (motor, pump, solenoid valves etc.).
- ⇒ Control of the sensors (pressure switches, motor speed, door status etc.).
- ⇒ Control of the user interface
- ⇒ Control of the serial port
- ⇒ Control of power failure procedure and alarms
- ⇒ Execution of the washing programme
- ⇒ Power failure, i.e. the information necessary to restart the appliance in the event of a power failure:
 - Selected cycle and options
 - Current phase and sub-phase
- ⇒ Machine status, used to perform special cycles such as:
 - Electrical test (used in the assembly line)
 - Continuous cycles (used in the factory workshop)
- ⇒ Machine configuration: the data contained in the EEPROM define the characteristics of the model and are interpreted by the function software. The variables are as follows:
 - Type of appliance (front-loader, top-loader, compact)
 - Type of door interlock (PTC or instantaneous)
 - Anti-flooding safety device
 - Transmission ratio between drum pulley and motor pulley
 - Structure of the washing group
 - Power supply frequency (50/60 Hz)
 - Type of PCB (horizontal or vertical buttons)
 - Detergent drawer (3 or 4 compartments)
 - Final spin speed (600 – 1400 rpm)
- ⇒ Identification of the appliance:
 - Prod. N.
 - ELC
 - Serial number
- ⇒ Configuration of the user interface:
 - Programmes on main selector
 - Function of secondary selector (if featured)
 - Number and functions of buttons
 - Functions of the LEDs
 - Operation of the buzzer

- ⇒ Washing cycle tables: Each washing cycle consists of a series of phases (steps); the steps are the basic instructions which comprise the description of the cycle, which is common to all appliances having the same characteristics:
 - Water fill
 - Motor movement
 - Reset
 - Heating
 - Drain
 - Spin
 - "IF" conditions (options, temperatures etc.)
- ⇒ Configuration of the washing cycle: for each family of appliances, certain parameters associated with the washing programme are defined:
 - Operational limits (voltage/frequency)
 - Transmission ratios
 - Parameters for control of the signal from the tachometric generator
 - Parameters for half-range operation of the motor
 - Structure of the washing group
 - Control parameters for the FUCS anti-unbalancing system
 - Water fill control algorithm
 - Alarm control system
 - Sensor parameters (flowmeter etc...)

9.1.3 RAM

The RAM (Random-Access Memory) contains the variables, i.e. all the dynamic information used during execution of the programme:

- ⇒ Motor speed
- ⇒ Water temperature
- ⇒ Alarms
- ⇒ Cycle selected
- ⇒ Machine status

The RAM is cancelled when the power supply is disconnected (power failure or appliance switched off).

The contents of the RAM can be read using a computer connected via a DAAS interface.

The same system can be used to send commands to the electronic control unit such as:

- ⇒ Select remote control mode
- ⇒ Action the various loads in remote mode
- ⇒ Select diagnostic mode
- ⇒ Select a cycle and options, and start the cycle

9.2 Door interlock

There are two types of door interlock:

- voltmetric with PTC
- instantaneous

9.2.1 Voltmetric interlock with PTC

- 10 Suppressor
- 19 Door interlock
- 20 PCB

ON/OFF = Main switch (programme selector)

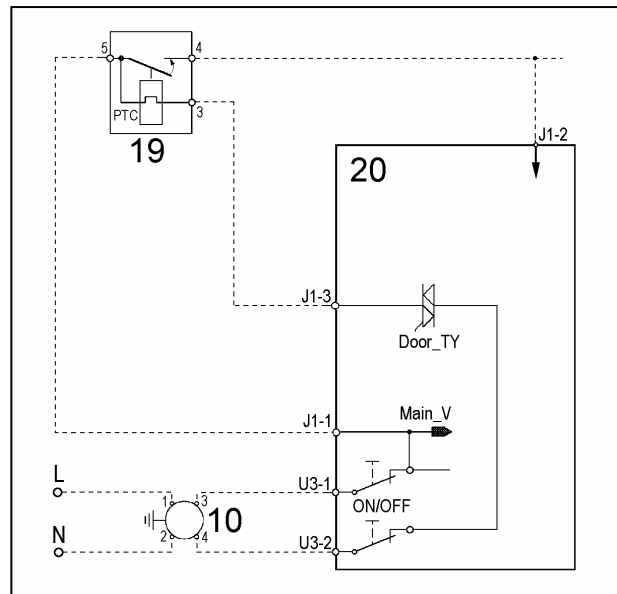

9.2.1.1 Operating principle

- ↪ When the washing programme is started by pressing the START/PAUSE button, the bi-metal PTC (contacts 3-5) is powered by the triac on the PCB: after 2 – 4 seconds, this closes the switch (5-4) which powers the electrical components of the appliance (only if the door is closed).
- ↪ The door interlock prevents aperture of the door while the appliance is in operation.
- ↪ At the end of the washing programme, the PCB disconnects the interlock from the power supply, but the door remains locked for 1 to 3 minutes (PTC cooling time).

9.2.2 Instantaneous door interlock

- With this safety device it is possible to open the door immediately after the end of the cycle.

9 Door interlock
 19 Suppressor
 20 PCB

ON/OFF = Main switch (programme selector)

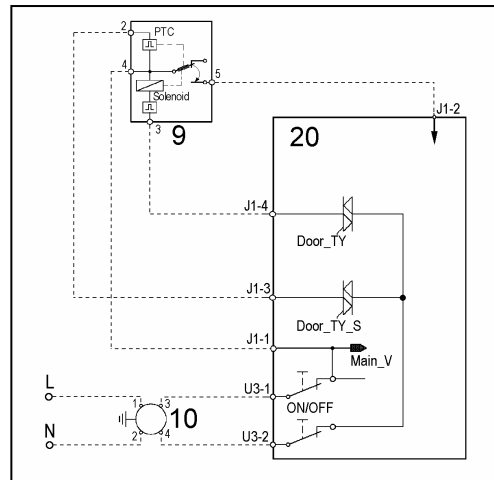

9.2.2.1 Operating principle

- ↪ When the ON/OFF switch closes and the appliance is switched on, power is applied to the bimetallic PTC switch (contact 4-2), but the door remains unlocked.
- ↪ When the programme starts (Start/Pause button), the main board sends a 20 msec pulse to contacts 4-3 on the solenoid (at least 6 seconds must have passed since the appliance was switched on). This locks the door and simultaneously closes the main switch (contacts 4-5), thus applying power to all components on the appliance.
- ↪ When the programme ends, the main board sends two additional 20 msec pulses (200 msec apart):
 - the first pulse does not unlock the door
 - the second pulse (which is sent only if the appliance is operating properly) unlocks the door lock device and simultaneously opens the contacts on the main switch.

9.2.2.2 Conditions required for opening the door

- ↪ Before pulses are sent to open the door, the main board checks for the following conditions:
 - The drum must not be moving (no signal from the tachometric generator).
 - The water level must not be higher than the bottom of the door.
 - The water temperature must not exceed 40° C.

9.2.2.3 Automatic unlock

If a power failure occurs, if the appliance is shut off, or if the solenoid malfunctions, the bimetallic PTC will cool down and the door will unlock in 1 - 4 minutes.

9.3 Water fill system

The electric valves are powered by the PCB by means of the triac and the control of the water level in the tub is carried out by the analogue pressure switch.

- 3 Analogue pressure switch
- 5 Prewash electric valve
- 6 Wash electric valve
- 7 Bleach electric valve
- 20 PCB

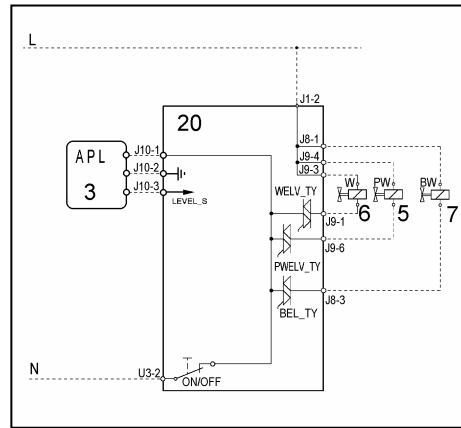

9.4 Analogue pressure switch of water level control in the tub

General features

The electronic pressure switch is an analogue device that controls the water level in the tub, used in the models with electronic control and it is directly connected to the main PCB.

ELECTRONIC PRESSURE SWITCH		
Electronic pressure switch	Electric symbol	

The pressure switch is connected by a hose to the pressure chamber.

When the tub is filled with water, the pressure created inside the hydraulic circuit expands the diaphragm. This in turn modifies the position of the core inside the coil, thus changing the inductance and the frequency of the oscillating circuit.

The electronic PCB, according to the frequency, recognizes the quantity of the water in the tub.

- 1 hose
- 3 coil
- 5 core

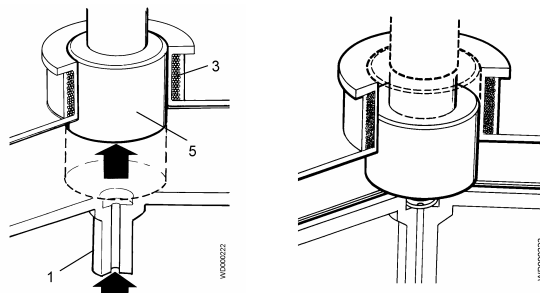

Frequency variation according to the water quantity in the tub

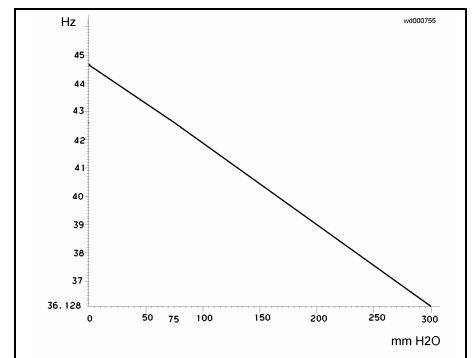

9.5 Drain pump

- 15 Drain pump
- 16 Thermal protector
- 20 PCB

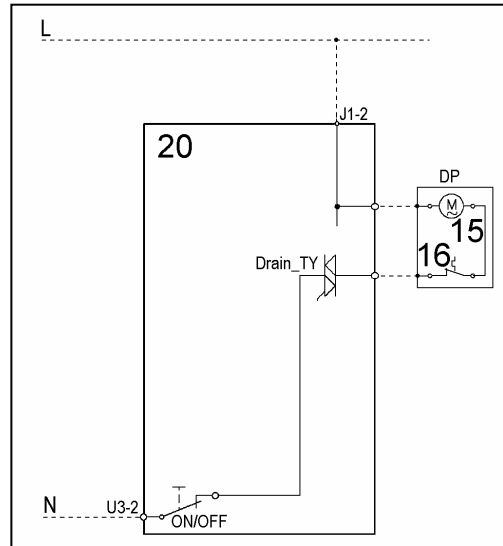

The PCB powers the drain pump via a triac as follows:

- until the electronic pressure switch closes on empty, after which the pump is actioned for a brief period or passes to the subsequent phase;
- for a pre-determined period (and eventually an alarm appears).

9.6 Recirculation pump (if featured)

On jetsystem models, the main board powers the recirculation pump through a triac.

- 17 Drain pump
- 18 Thermal protector
- 20 PCB

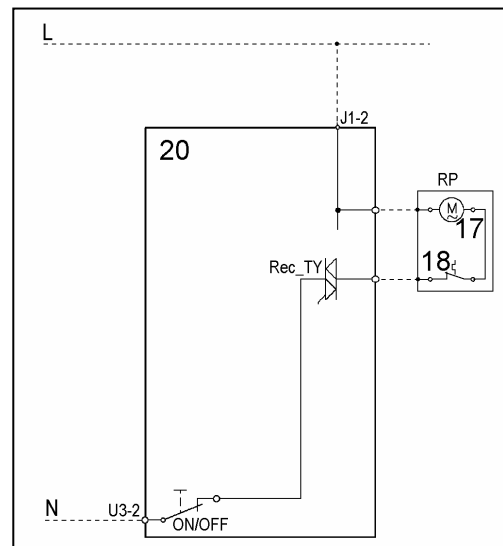

9.7 Heating



- 2 NTC temperature sensor
- 13 Heating element (with thermal fuses)
- 14 PCB
- K1 Relay

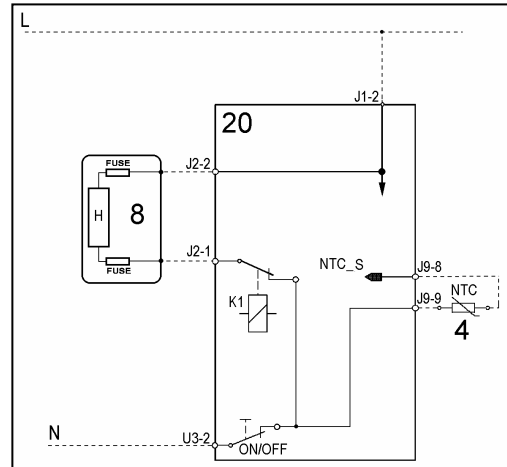

- 1. Tubular casing
- 2. Thermal fuses
- 3. NTC Sensor
- 4. Connectors

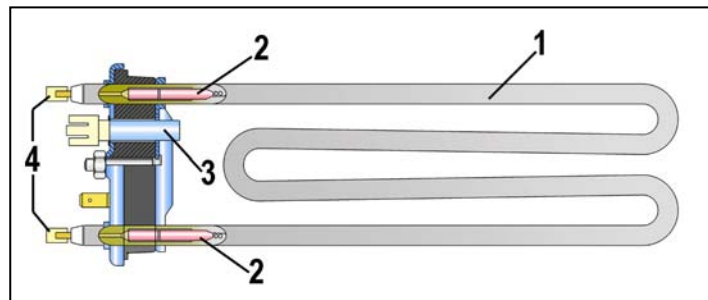

The heating element is powered by a relay (K1) of the electronic board and is provided with two thermal fuses, which interrupt if the temperature degree exceeds the values by which they are calibrated.

WARNING



In case of replacement of the heater, replace it with one with the same characteristics in order not to compromise the safety of the appliance.

9.8 Temperature sensor

The temperature is controlled by the PCB by means of a NTC temperature sensor incorporated in the heating element.

- 1. NTC resistor
- 2. Metallic capsule
- 3. Terminals
- 4. Plastic casing

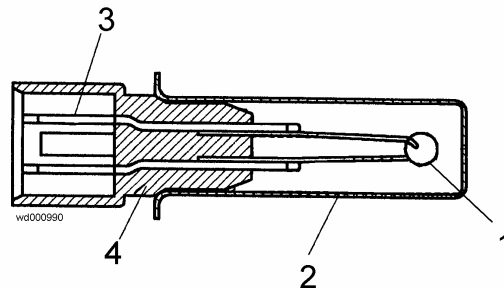

TEMPERATURE (°C)	RESISTANCE (Ω)		
	Nominal value	Maximum value	Minimum value
20	6050	6335	5765
60	1250	1278	1222
80	640	620	660

9.9 Three-phase asynchronous motor

- 11. Tachometric generator
- 20. PCB
- 23. Inverter
- 24. Motor

X-Y-X = Motor windings

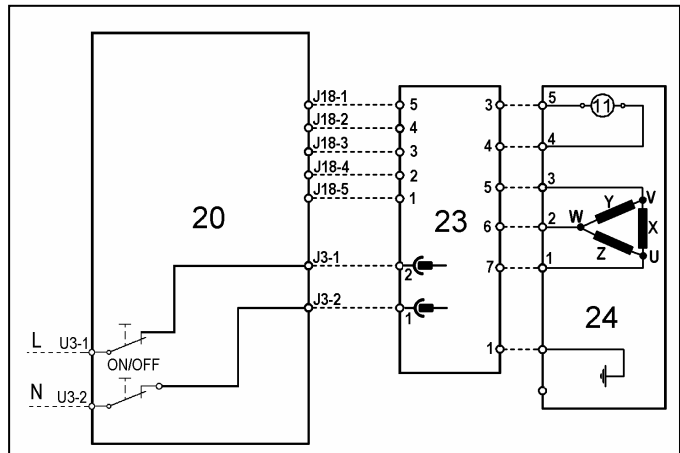

9.9.1 Power supply to motor

Three-phase power is fed by the inverter (4) which sends, through the connectors 5-6-7, the three phases to connectors 1-2-3 on the motor (nodes V-W-U), where the windings (Y-X-Z-) are connected. The phase shift between the phases is 120° and peak amplitude is 310V.

The condition of the motor can be determined by measuring the resistance of the windings:

- Winding y ohm 5,4 $\sim \pm 7\%$ (contacts 2-3)
- Winding x ohm 5,4 $\sim \pm 7\%$ (contacts 1-2)
- Winding z ohm 5,4 $\sim \pm 7\%$ (contacts 1-3)
- Winding T (tachometric) ohm 121 $\sim \pm 7\%$ (contacts 4-5)

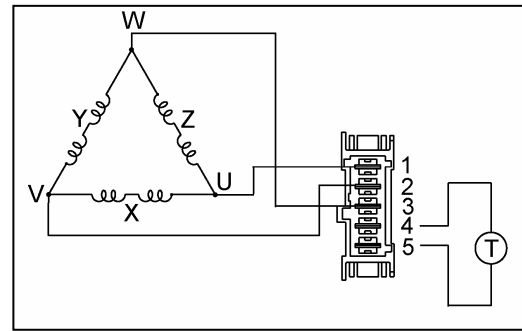

- The electrical components must be serviced by qualified personnel only.
- Unplug the appliance before accessing internal components.

9.10 Anti-foam control system

The anti-foam control procedure (if featured) is performed via the anti-boiling pressure switch.

Spin phase without foam

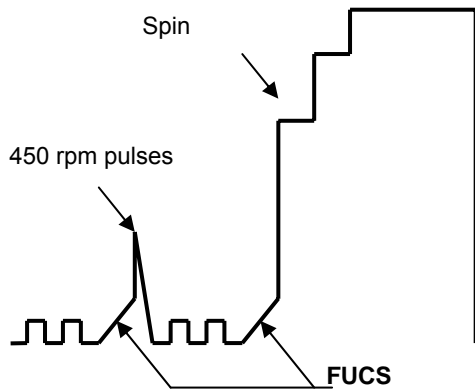

Spin phase with little foam

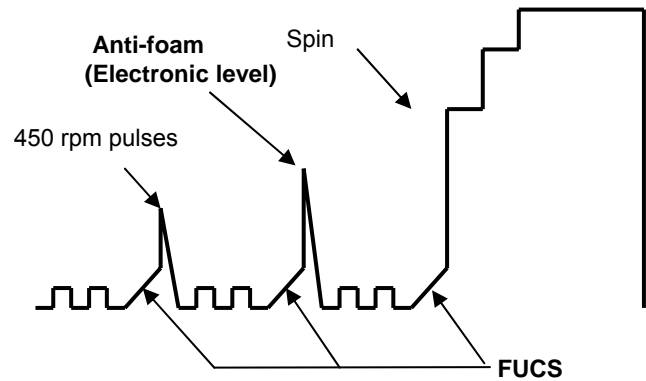

- **Spin with little foam:** if the contact of the electronic pressure switch closes on FULL, the spin phase is interrupted; the drain pump continues to operate and, when the contact returns to EMPTY, the spin phase is resumed.
- **Spin with excessive foam in the tub (critical situation):** The control system detects whether the electronic pressure switch commutates 5 times to FULL. In this case, the spin phase is skipped, and a one-minute drain cycle is performed with the motor switched off; in the case of a washing phase, a supplementary rinse is added.

9.11 FUCS (Fast Unbalance Control System)

The control procedure for unbalanced loads is performed dynamically, before each spin cycle, as follows:

- ↪ The phase begins at a speed of 55 RPM. The speed may not drop below this threshold; if it does, the check is repeated.
- ↪ At intervals of 300 ms, the balance is calculated and compared with established limits. If the value is lower than the limit, drum speed is increased by a certain amount that depends on the transmission ratio between the motor pulley and the drum. If unbalance is greater than the limit, the speed is decreased by the same amount, which enables the laundry to arrange itself correctly. The process continues until the load is completely balanced.
- ↪ Correct balancing of the load occurs at 115 RPM. After this speed is reached, the spin cycle begins.

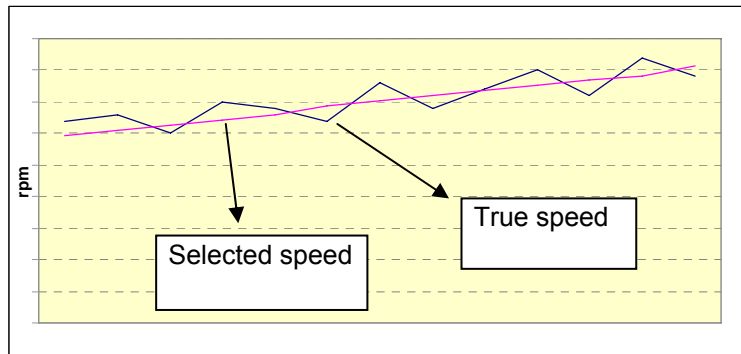

The unbalance control procedure may be performed in a number of phases. Each phase involves:

- ↪ an unbalancing rating (0-1-2-3)
- ↪ an unbalancing threshold (ex: 350, 650, 850, 1200g)
- ↪ a timeout

- **Conclusion of the FUCS procedure**

The FUCS procedure is considered to be concluded when:

- ↪ The speed of drum rotation is 115 RPM (or 85 RPM for certain unbalance ratings). At this point, the scheduled spin phase is carried out.
- ↪ In some cases, optimum balance is not reached and the spin is performed at a lower speed that depends on the level of unbalance.
- ↪ In the worst case scenario, a minimum level of balance is not achieved after all the FUCS phases have been performed and the spin phase is skipped.

- **Situation of ideal balancing**

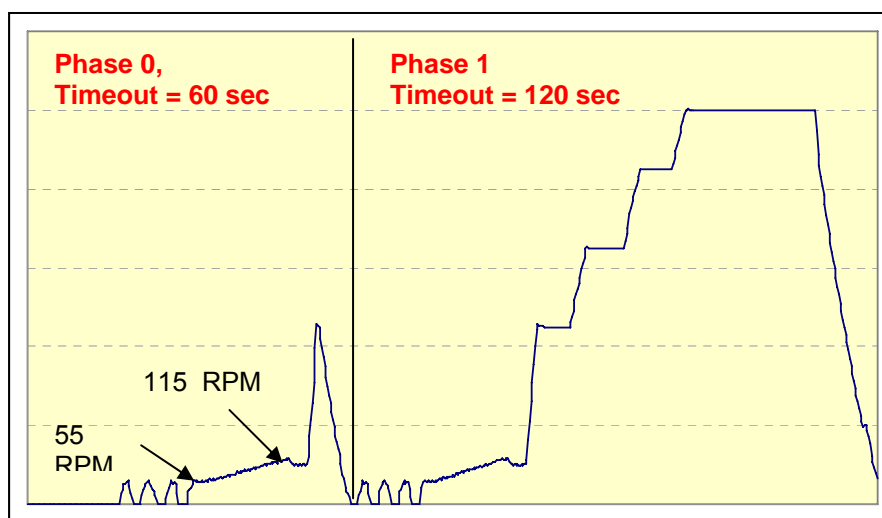

- An example of drum balancing in the longest interval of time available

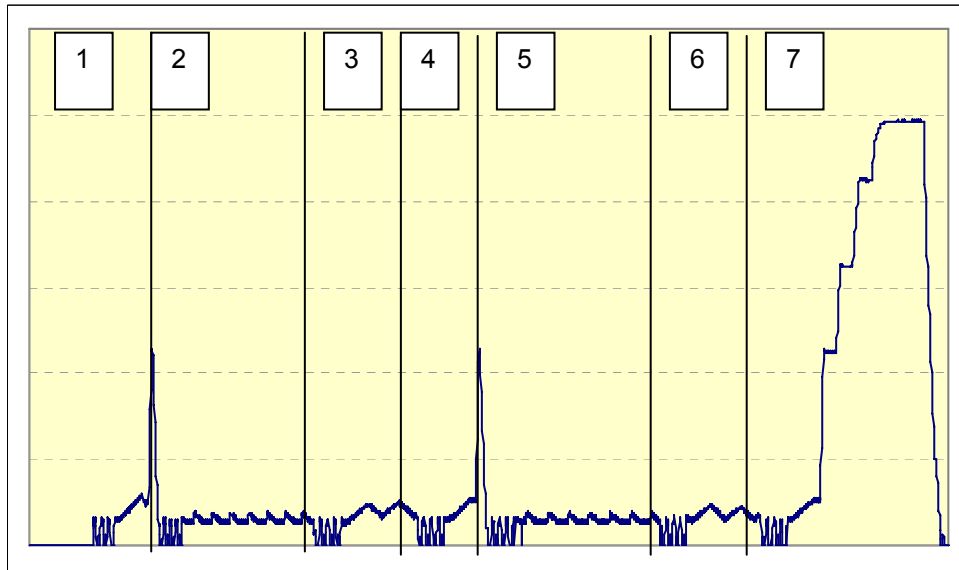

Phase	Unbalance rating	Time-out (sec)
1	0	60
2	1	120
3	2	60
4	3	90
5	1	120
6	2	60
7	3	90

- An example of unbalancing after all FUCS phases have been performed

In this case, the spin (or pulse operation) is skipped.

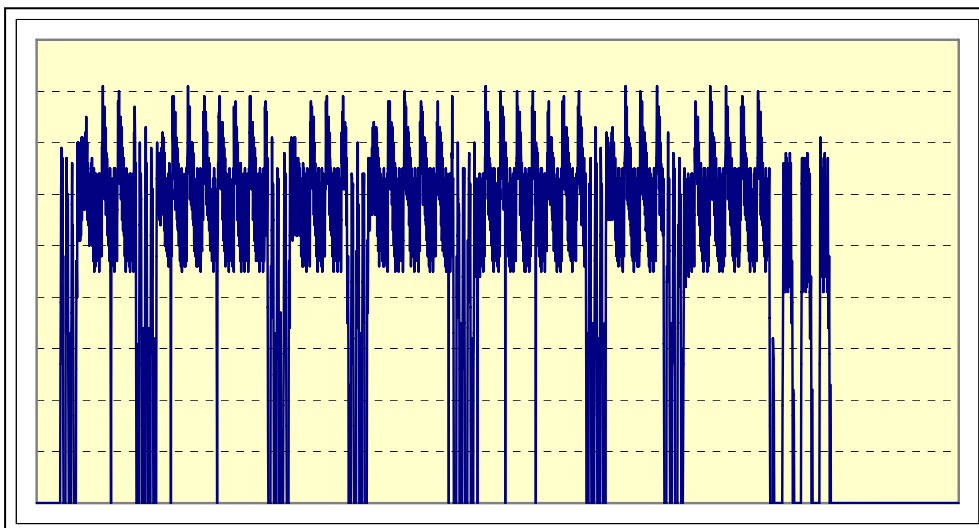

9.12 Table of alarm codes

Alarm	Possible fault	Action/machine status	Reset
E11	Tap closed or water pressure too low; Drain tube improperly positioned; Water fill solenoid valve is faulty; Leaks from water circuit on pressure switch; Pressure switch faulty; Wiring faulty; PCB faulty.	Cycle is paused with door locked.	START/RESET
E13	Drain tube improperly positioned; Water pressure too low; Water fill solenoid valve is faulty; Water circuit on pressure switch is leaking/clogged; Pressure switch faulty.	Cycle is paused with door locked.	START/RESET
E21	Drain tube kinked/clogged/improperly positioned; Drain filter clogged/dirty; Drain pump faulty; Pressure switch faulty; Wiring faulty; PCB faulty; Electrical current leak between heating element and ground.	Cycle is paused (after 2 attempts).	START/RESET
E23	Drain pump faulty; Wiring faulty; PCB faulty.	Safety drain cycle - Cycle stops with door unlocked.	RESET
E24	PCB faulty.	Safety drain cycle - Cycle stops with door unlocked.	RESET
E31	Pressure switch; Wiring; Main PCB.	Cycle stops with door locked.	RESET
E32	Tap is closed or water pressure is too low; Solenoid valve; Water circuit on pressure switch; pressure switch; Wiring; main board.	Cycle is paused.	START/RESET
E35	Water fill solenoid valve is faulty; Leaks from water circuit on pressure switch; Pressure switch faulty; Wiring faulty; PCB faulty.	Cycle stops. Safety drain cycle. Drain pump continues to operate (5 min. on, then 5 min. off, etc.).	RESET
E38	Water circuit on pressure switches; Pressure switches; Motor belt broken.	Heating phase is skipped.	ON/OFF RESET
E3A	PCB faulty.	Cycle stops with door locked.	RESET
E41	Door lock unit faulty; Wiring faulty; PCB faulty.	Cycle is paused.	START/RESET
E42	Door lock unit faulty; Wiring faulty; PCB faulty; Electrical current leak between heating element and ground.	Cycle is paused.	START/RESET
E43	Door lock unit faulty; Wiring faulty; PCB faulty.	(Safety drain cycle) Cycle stops.	ON/OFF RESET
E44	PCB faulty.	(Safety drain cycle) Cycle stops.	ON/OFF RESET
E45	PCB faulty.	(Safety drain cycle) Cycle stops.	ON/OFF RESET
E51	PCB faulty; current leakage from motor or from wiring.	Cycle blocked, door locked (after 5 attempts).	RESET
E52	Motor faulty; wiring faulty; PCB faulty.	Cycle blocked, door locked (after 5 attempts).	RESET
E53	PCB faulty.	Cycle blocked.	RESET
E54	PCB faulty; current leakage from motor or from wiring.	Cycle blocked, door locked (after 5 attempts).	RESET
E57	Motor defective; Wiring defective on inverter for motor, inverter board defective.	Cycle stops with door locked (after 5 attempts).	RESET

Alarm	Possible fault	Action/machine status	Reset
E58	Motor defective; Wiring defective on inverter for motor, inverter board defective, abnormal motor operation (motor overloaded).	Cycle stops with door locked (after 5 attempts).	RESET
E59	Motor defective; Wiring defective on inverter for motor; Inverter board defective.	Cycle stops with door locked (after 5 attempts).	RESET
E5A	Inverter board defective. NTC open (on the inverter board). Overheating caused by continuous operation or ambient conditions (let appliance cool down)	Cycle stops with door locked (after 5 attempts).	RESET
E5B	Wiring defective, Inverter board defective	Cycle stops with door locked (after 5 attempts).	RESET
E5C	Inverter board defective, the masters voltage is too high (measure the masters voltage)	Cycle stops with door locked (after 5 attempts).	RESET
E5D	Line interference, Wiring defective, defective main board or inverter board	Cycle stops with door locked (after 5 attempts).	RESET
E5E	Defective wiring between main board and inverter board, Defective inverter board, defective main board.	Cycle stops	ON/OFF
E5F	Defective inverter board, Defective wiring, defective main board	Cycle stops with door locked (after 5 attempts).	RESET
E61	NTC sensor faulty; heating element faulty; wiring faulty; PCB faulty.	The heating phase is skipped.	START/RESET
E62	NTC sensor faulty; heating element faulty; wiring faulty; PCB faulty.	Safety drain cycle – Cycle stopped with door open.	RESET
E66	PCB faulty .	Safety drain cycle – Cycle stopped with door open.	RESET
E68	Earth-leakage between heater and earth.	Cycle blocked with door open.	RESET
E71	Faulty NTC sensor; Wiring faulty; PCB faulty.	Heating is skipped.	START/RESET
E74	NTC sensor improperly positioned; Faulty NTC sensor; Wiring faulty; PCB faulty.	Heating is skipped.	START/RESET
E82	PCB faulty (Wrong configuration data). Selector, wiring	-----	RESET
E83	PCB faulty (Wrong configuration data). Selector, wiring	Cycle cancelled.	START/RESET
E91	Wiring faulty; Faulty control/display board PCB faulty.	-----	RESET
E92	Wrong control/display board; Wrong PCB (do not correspond to the model).	Cycle interrupted.	OFF/ON START
E93	Incorrect configuration data; PCB faulty.	Cycle interrupted.	OFF/ON
E94	Incorrect configuration data; PCB faulty.	Cycle interrupted.	OFF/ON
E95	PCB faulty.	Cycle interrupted.	RESET
E97	Faulty PCB (Wrong configuration data).	Cycle interrupted.	RESET
E98	Incompatibility between main board and Inverter	Cycle interrupted.	OFF/ON
E99	Main PCB.	Cycle interrupted.	OFF/ON
E9B	Display board.	Cycle interrupted.	Reset
E9C	Display board.	Cycle interrupted.	Reset
E9D	Display board.	Cycle interrupted.	Reset
E9F	Main PCB.	Cycle interrupted.	OFF/ON

Alarm	Possible fault	Action/machine status	Reset
EH1	Power supply problems (incorrect / disturbance); PCB faulty.	Wait for frequency nominal conditions.	OFF/ON
EH2	Power supply problems (incorrect / disturbance); PCB faulty.	Wait for voltage nominal conditions.	OFF/ON
EH3	Power supply problems (incorrect / disturbance); PCB faulty.	Wait for voltage nominal conditions.	OFF/ON
EHE	Wiring faulty; PCB faulty.	Safety drain cycle – Cycle stopped with door open.	RESET
EHF	PCB faulty.	Safety drain cycle – Cycle stopped with door open.	RESET
EC1	Solenoid valve faulty/blocked; PCB faulty.	Cycle interrupted with door closed. Drain pump functions always (5 min., then it stops for 5 min. etc.)	RESET
EC3	Wiring faulty; Weight sensor faulty; PCB faulty.	-----	START/RESET
EF1	Drain tube blocked/kinked/too high; Drain filter dirty/blocked.	Warning displayed at the end of cycle (specific LED).	START/RESET
EF2	Excessive detergent dosing; drain tube kinked/blocked; Drain filter dirty/blocked.	Warning displayed after 5 attempts or by the specific LED.	RESET
EF3	Water leaks onto base frame; water control system defective.	Machine drains and cycle stops	ON/OFF RESET
EF4	Tap closed, water pressure too low	-----	RESET
EF5	Final spin phases skipped.	-----	RESET
E00	-----	-----	-----

10 Diagram with THREE-PHASE ASYNCHRONOUS MOTOR

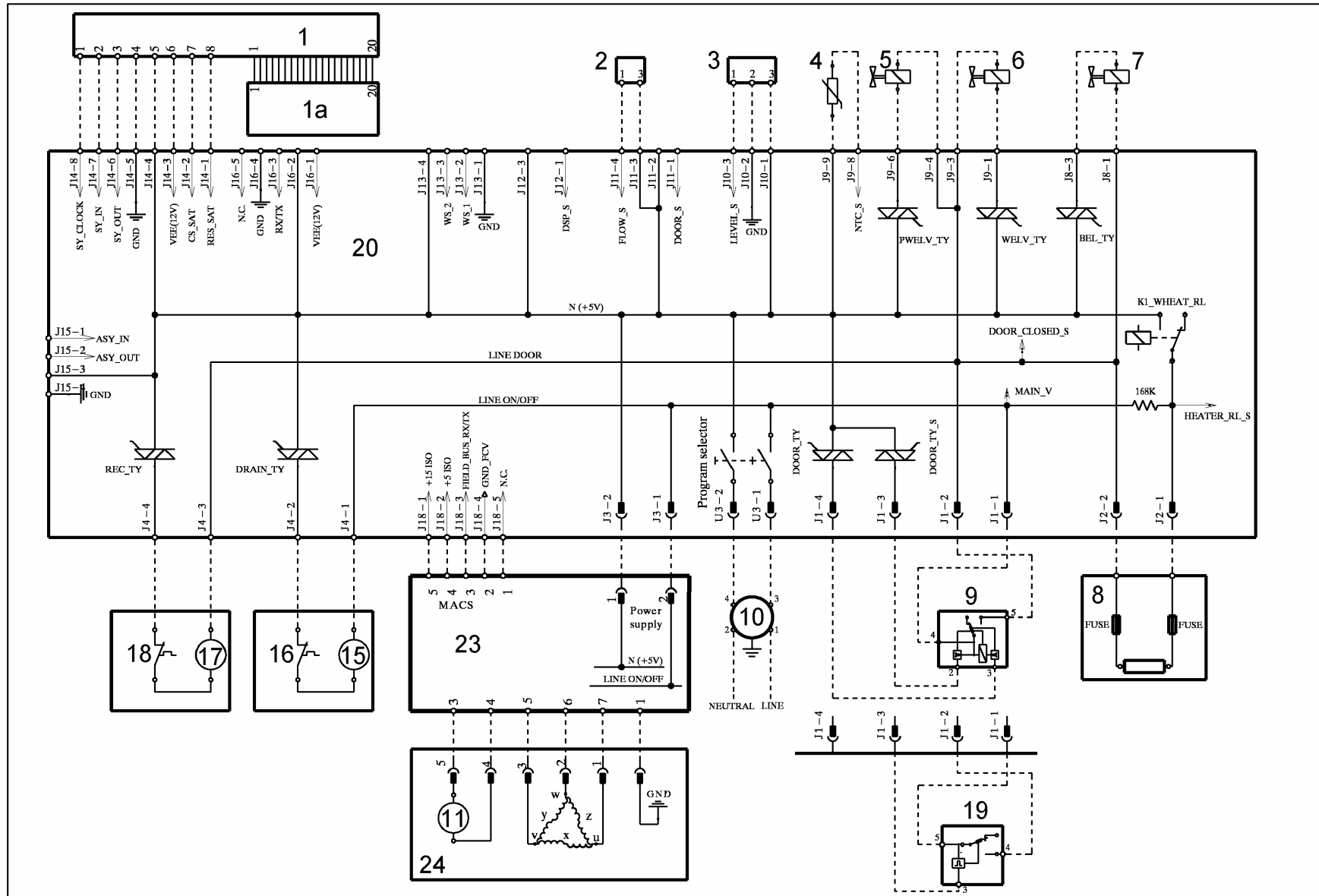

- Key to diagram with THREE-PHASE ASYNCHRONOUS MOTOR

Electrical components on appliance	Components on main board	
1. Display board 1a. LCD display 2. Flowmeter 3. Analogue pressure switch 4. NTC temperature sensor 5. Solenoid valve for prewash 6. Solenoid valve for wash 7. Solenoid valve for bleach 8. Heating element (with thermofuses) 9. Door interlock (instantaneous) 10. Suppressor 15. Drain pump 16. Thermal cut-out (drain pump) 17. Recirculation pump 18. Thermal cut-out (recirculation pump) 19. Door interlock (with PTC) 20. PCB 23. Inverter 24. Three-phase motor	DOOR_TY DRAIN_TY REC-TY K1 ON/OFF PWELV_TY WELV_TY BEL_TY	Door interlock Triac Drain pump Triac Recirculation pump Triac Heating element relay Main switch (programme selector) Pre-wash solenoid Triac Wash solenoid Triac Bleach solenoid Triac

11 ACCESSIBILITY

11.1 To the electronic control system

11.1.1 Work top

- a. Remove the two rear screws, push the top panel towards the rear and release from the cabinet.

11.1.2 Control panel

- b. Press the drawer lock.
- c. Extract.

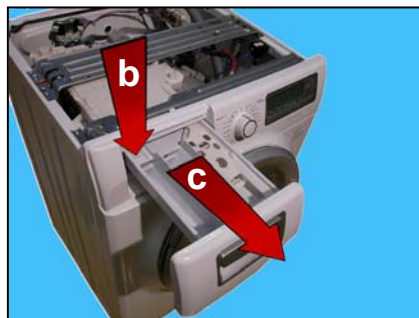

- d. Remove the screw which secures the control panel to the dispenser.



- e. Remove the clamp which secures the wiring to the board casing.

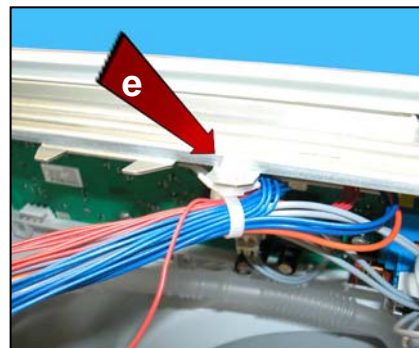

- f. Release the wiring from the clamp under the dispenser.

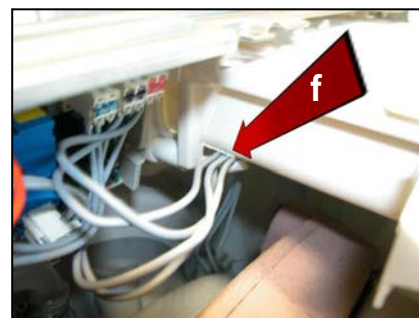

After releasing the wiring from the fixing hooks.



g. Loosen the screws which secure the cross-member to the cabinet.

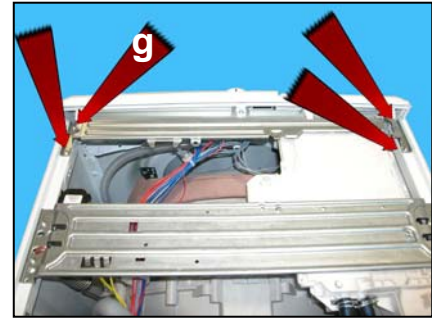

h. Release the hook which secures the dispenser to the cross-member.

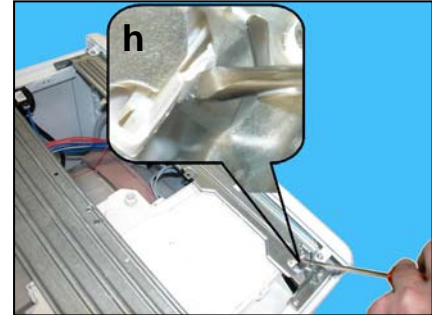

i. Lift the control panel up.



j. Loosen the screws which secure the cross-member to the control panel.

k. Release the hook which secures the control panel to the cross-member.

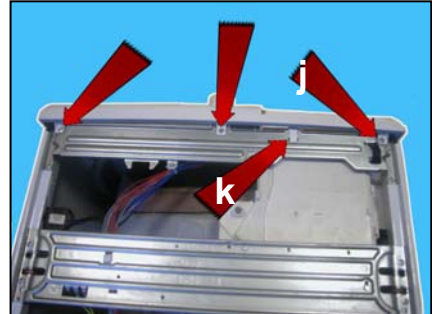

l. Turn and insert a protection between the control panel and the surface which you lean it on to avoid damaging it.

m. To extract the board, remove the screws which secure it to the control panel.

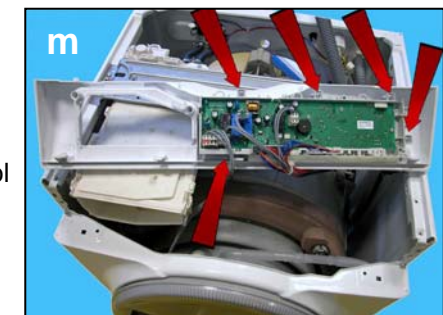

n. To remove the button springing system, release the two hooks which secure it to the main board.



11.2 Door interlock

- a. Remove the ring that secures the bellow gasket to the cabinet.



- b. Remove the bellow gasket.
- c. Remove the screw which secures the door interlock to the front side.
- d. Push inside the hook.
- e. Push it upwards.
- f. Extract the door interlock.

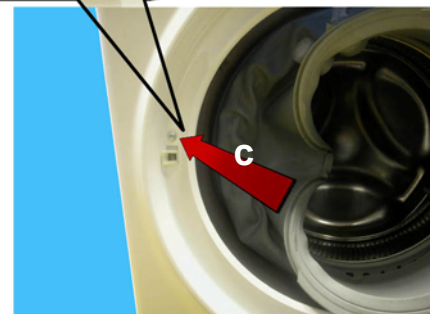
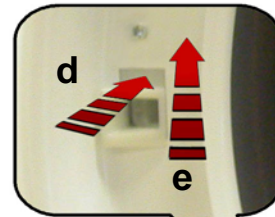

11.3 New drain filter

- a. Open the filter door with the appropriate tool (supplied with the appliance), because it is locked.



To empty the drain circuit:

- b. Remove the cap in the filter knob (after positioning a vessel to collect the water).

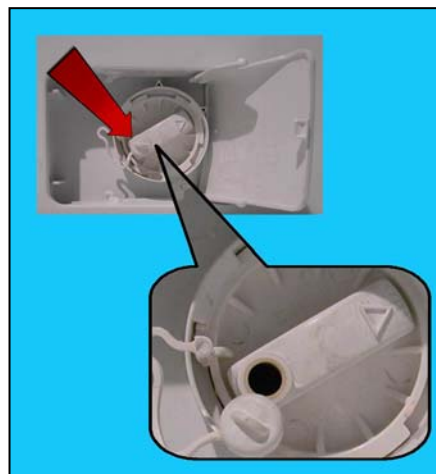

- c. Turn the cap left to align the two references: (the arrow in the cap and the reference point in the filter body), so as to allow extracting the filter.
- d. Extract the filter.

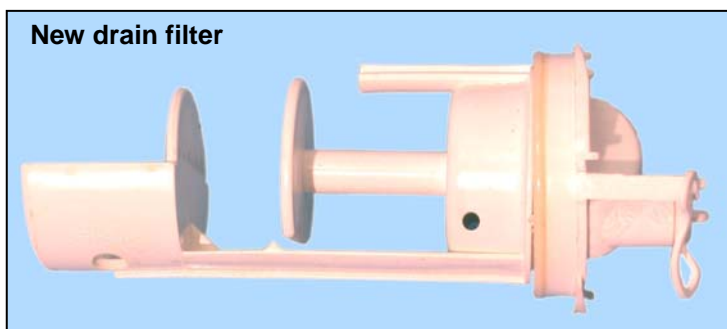
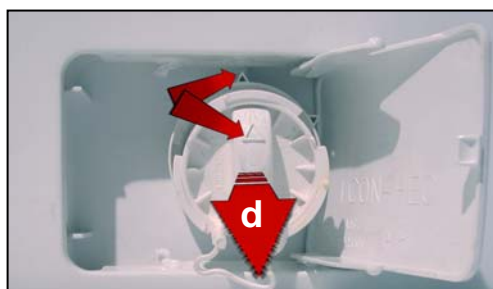

11.4 Inverter board

- a. Release the hook.
- b. Push the hook inside, extract it.
- c. Push the wing which secures the board the cabinet.

