



	Washing machines	
	P6000 (Nexus) Series	
<p>© ELECTROLUX HOME PRODUCTS ITALY S.p.A. Spares Operations Italy Corso Lino Zanussi, 30 I - 33080 PORCIA /PN (ITALY)</p> <p>Fax +39 0434 394096</p>	<p>Publication number 599 37 38-46</p> <p>EN/dmm</p> <p>Structural characteristics, electrical components and accessibility</p>	
<p>Edition: 2005.11.03</p>	<p>Production: THR RAYONG- Thailand</p>	

CONTENTS

1	PURPOSE OF THIS SERVICE MANUAL	6
2	IMPORTANT NOTES.....	6
3	WASHING PRINCIPLES	7
3.1	Washing	7
3.1.1	Results of the wash	7
3.2	Fabrics	8
3.2.1	Natural and artificial fibres	8
3.2.2	Washing the various types of fibres	8
	Washing animal fibres:.....	8
3.2.3	International symbols for washing of fabrics	9
3.3	Classification of soiling	10
3.4	Mechanical action	10
3.5	Duration of the washing cycle.....	10
3.6	Water	11
3.6.1	Formation of lime scale and ferrous oxide	11
3.6.2	Hardness of the water	11
3.6.3	Total water hardness.....	12
3.7	Detergents	13
3.7.1	Composition of a detergent	13
3.7.2	Functions of the principal components of a detergent	13
3.7.3	Functions of other components of a detergent.....	14
3.7.4	Detergent quantities	15
3.7.5	Washing additives	16
3.7.6	Bleaching	16
3.8	The function of the water temperature.....	17
3.8.1	Using the correct temperature	17
3.9	Washing machine programmes	18
3.10	Control panel.....	19
3.11	“JETSYSTEM” washing system.....	20
3.11.1	Jetsystem “DIRECT SPRAY” washing system.....	20
4	STRUCTURAL CHARACTERISTICS	21
4.1	“NEXUS” technology.....	21
4.2	Base.....	21
4.3	Control panel support	22
4.4	Cabinet.....	22
4.5	Door	23
4.6	Washing groups.....	24
4.6.1	Damper	24
4.6.2	Washing group in Carboran	25
4.6.3	Drum.....	26
4.6.4	Drum rotation drive belt	27
4.7	Detergent dispenser	28
4.7.1	Detergent dispenser with multiple-outlet solenoid valve	28
4.8	“NEW JET” circulation circuit.....	30
5	ELECTRICAL COMPONENTS	31
5.1	Suppressor.....	31
5.1.1	General characteristics.....	31
5.1.2	Electrical symbols.....	31
5.1.3	Circuit diagrams.....	31
5.1.4	Checking for efficiency	31
5.2	Push-button.....	32
5.2.1	General characteristics.....	32
5.2.2	Electrical symbol.....	32
5.2.3	Checking for efficiency	32
5.3	Instantaneous door safety interlock.....	33
5.3.1	General characteristics.....	33
5.3.2	Operating principle	33
5.3.3	Electrical symbol.....	34
5.3.4	Circuit diagram	34
5.4	Solenoid valve	35
5.4.1	General characteristics.....	35
5.4.2	Electrical symbol.....	35
5.4.3	Checking for efficiency	35

5.5	Pressure switch	36
5.5.1	General characteristics	36
5.5.2	Pressure switch hydraulic circuit	36
5.5.3	Electrical symbol.....	37
5.5.4	Circuit diagram	37
5.5.5	Checking for efficiency	37
5.6	Analogue (electronic) pressure switch.....	38
5.6.1	General characteristics	38
5.6.2	Operating principle	38
5.6.3	Electrical symbol.....	39
5.6.4	Circuit diagrams and operating frequency.....	39
5.6.5	Checking for efficiency	39
5.7	Induction (asynchronous) motors	40
5.7.1	General characteristics.....	40
5.7.2	Operating principle	40
5.7.3	Checking the efficiency.....	40
5.8	Commutator motor.....	41
5.8.1	General characteristics.....	41
5.8.2	Operating principle	41
5.8.3	Electrical symbols.....	43
5.8.4	Circuit diagram	44
5.8.5	Checking for efficiency	44
5.9	Heating element.....	45
5.9.1	General characteristics.....	45
5.9.2	Electrical symbol.....	45
5.9.3	Checking for efficiency	45
5.10	NTC temperature sensor integrated in the heating element.....	46
5.10.1	General characteristics.....	46
5.10.2	Electrical symbol.....	46
5.11	Drain pump.....	47
5.11.1	General characteristics.....	47
5.11.2	Electrical symbol.....	47
5.11.3	Checking for efficiency	47
5.12	Circulation pump	48
5.12.1	General characteristics.....	48
5.12.2	Electrical symbol.....	48
5.12.3	Checking for efficiency	48
6	ACCESS TO COMPONENTS	49
6.1	Work-top	49
6.1.1	Pressure switch	49
6.1.2	Suppressor	49
6.1.3	Solenoid valve	49
6.2	Control panel.....	50
6.2.1	Push-button	50
6.3	Electronic control	50
6.3.1	Main electronic control (EWM2000EVO-EWM3000NEW).....	50
6.3.2	Control/display board.....	51
6.3.3	Electronic pressure switch.....	51
6.4	Access from the door.....	51
6.4.1	Door.....	51
6.4.2	Door hinge	51
6.4.3	Door safety interlock.....	52
6.4.4	Bellow seal	52
6.5	Rear cabinet shell	53
6.5.1	Motor.....	53
6.5.2	Heating element	53
6.5.3	Detergent dispenser	54
6.5.4	Removing the duct from the dispenser.....	54
6.5.5	Damper	54
6.5.6	Drum pulley	55
6.5.7	Pressure chamber	55
6.6	Washing group.....	55
6.7	Drum and tub shells.....	55
6.7.1	Drum shaft bearings	56
6.7.2	Drum spider	56

6.7.3	Front counterweight.....	56
6.8	Drum lifter	57
6.9	Access to the pumps/manifolds.....	58
6.9.1	Drain pump (standard version).....	58
6.9.2	Drain pump	58
6.9.3	Circulation pump.....	59
6.9.4	Drain filter body	59
6.9.5	Base.....	59
6.10	Front cabinet shell.....	60

1 PURPOSE OF THIS SERVICE MANUAL

The purpose of this Service Manual is to provide Service Engineers, who already have the basic knowledge necessary to repair household washing machines, with information of a general nature regarding the P6000 (Nexus) range of washing machines.

More detailed information regarding specific models may be found in the Service Notes and Service Manuals (issued separately) for each specific model or functionality.

This information covers:

- Circuit diagrams
- Timer diagrams
- Exploded diagrams of spare parts
- Lists of spare parts
- Functions and diagnostics.

2 IMPORTANT NOTES

- Repairs to electrical appliances must be effected only by qualified personnel.
- Before accessing the components inside the appliance, always remove the plug from the power socket.
- Where possible, ohmic measurements should be effected rather than direct measurement of voltage and current.
- Functional operation of the appliance may be checked when the rear panel has been removed. However, under no circumstances must a spin cycle be performed with washing in the drum. In addition, spin tests without washing must be performed with care and for short periods only. The front panel alone is not sufficient to maintain the balance of the appliance during spinning.
- Certain metal components inside the appliance may have sharp edges. Care should be taken to avoid cuts or abrasions.
- Before laying the appliance on the floor, always drain any water by removing the filter or laying the drain hose flat on the floor.
- Never lay the appliance on its right side (i.e. timer / electronic control unit side); this would cause the water in the detergent dispenser to fall onto electrical components, thus damaging them.
- After removing the rear panel of the cabinet, the appliance should be laid down on the front panel only, preferably placing a sheet of cardboard on the floor to protect the paintwork.

- After removing the rear panel from the appliance, it is necessary to cover the two extremities of the upper cross-member with protective material, for example by wrapping them in a cloth or fitting the terminal section of the drain hose. This precaution is necessary because the edges of the brackets are sharp, and might otherwise cause injury to the head when working on the appliance from the rear.

- After repairing the appliance, always perform the final tests.

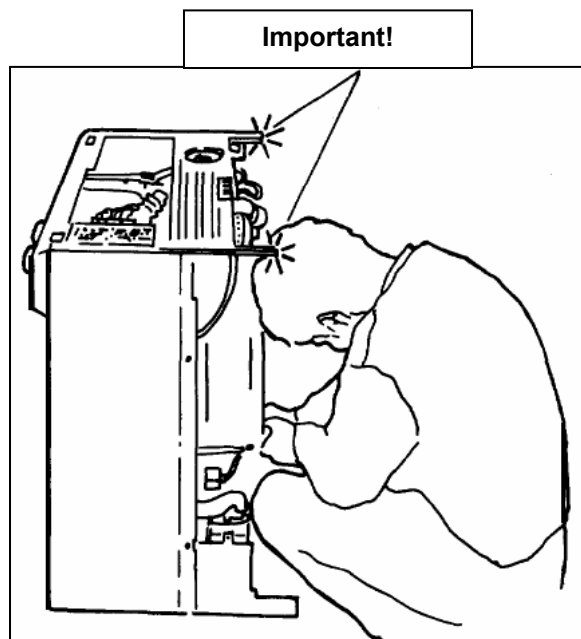

3 WASHING PRINCIPLES

3.1 Washing

The washing of the fabrics consists of transferring the dirt from the fabrics to the water, and is achieved using the following:

- detergent
- mechanical action
- temperature
- time

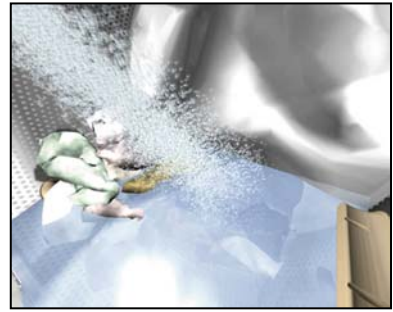

The washing operation comprises four phases:

1. Soaking (the fabrics must be completely soaked).
2. Dispersal of the dirt (which must be separated from the fabrics).
3. Suspension of the dirt (once removed from the fabrics, the dirt must not re-deposit, but must be held in suspension).
4. Elimination of the dirt by means of draining and rinses.

3.1.1 Results of the wash

In order to obtain satisfactory washing results, it is necessary to know:

- ◆ the nature of the fibres
- ◆ the nature of the soiling
- ◆ the hardness of the water
- ◆ the products used for the wash (detergent, conditioners, bleach etc.)

and then to select the appropriate washing cycles.

The results of the wash depend on a number of factors:

- type of fabric
- type of water
- type of soiling
- type and quantity of detergent
- temperature of the water
- efficiency of the rinses
- time and speed of the spin cycles

3.2 Fabrics



3.2.1 Natural and artificial fibres

NATURAL FIBRES	
ANIMAL FIBRES	Wool
	Special wool
	Silk
CELLULOSE VEGETABLE FIBRES	Cotton
	Linen
	Canapa
	Hemp
	Ramie
ARTIFICIAL FIBRES	
ARTIFICIAL CHEMICAL FIBRES	Viscosa rayon
	Cupro rayon
	Special rayons
	Rayon and polynosics
	Acetate rayon
	Triacetate rayon
SYNTHETIC CHEMICAL FIBRES	Polyamide fibres
	Polyurethane fibres
	Polyureic fibres
	Polyester fibres
	Polytechnical fibres

3.2.2 Washing the various types of fibres

Washing animal fibres:

- Neutral detergents
- Greater quantity of water
- Maximum temperature 40°C
- Minimum mechanical agitation, short times

Cellulose vegetable fibres:

- Alkaline (Base) detergents
- Bleach (if used): Sodium hypochlorite (NaClO)
- High water temperature (if OK for coloureds; for linen, if heavily soiled, bleaching is preferable to washing at high temperatures).
- Normal quantity of water
- Vigorous and prolonged mechanical action
- Spinning

Artificial chemical fibres:











- Neutral detergents
- Less mechanical action and minimum spinning
- Greater quantity of water
- Maximum temperature: 70°C (whites), 50°C (coloureds); bleach with a diluted solution of Sodium hypochlorite (NaClO) and hydrogen peroxide (H₂O₂)



Synthetic chemical fibres:





- Stronger detergents
- Maximum temperature 40-60°C
- Short wash
- Medium spin speed







3.2.3 International symbols for washing of fabrics





Labels marked with the following symbols are affixed to the garments, and provide valuable information relative to their treatment.

WASHING ACTION  NORMAL  DELICATE	 Wash at 95°C	 Wash at 60°C	 Wash at 40°C	 Wash at 30°C	 Delicate hand-wash	 DO NOT WASH
						

 BLEACH	 May be bleached in COLD water	 DO NOT BLEACH
--	--	---

 IRONING	 Hot iron max 200°C	 Medium iron max 150°C	 Cool iron max 110°C	 DO NOT IRON
---	---	--	---	---

 DRY-CLEANING						 DO NOT DRY-CLEAN
	These symbols are used by the dry-cleaner to identify the correct solvent and cleaning process for each garment to be dry-cleaned					

 DRYING	 Normal temperature  Reduced temperature Can be dried in a tumble-dryer	 DO NOT DRY IN A TUMBLE-DRYER
--	---	--

3.3 Classification of soiling

The dirt in the fabrics consists essentially of:

- PROTEICN-BASED substances
- OXIDABLE substances
- GREASE
- VARIOUS substances
- CHEMICAL substances

Protein soiling (enzymatic) - sensitive to ENZYMES

Blood, Eggs, Chocolate, Grass etc.

Oxidable substances - sensitive to BLEACH

Wine, Tea, Coffee, Fruit etc.

Greasy soiling - sensitive to SURFACE-ACTIVE AGENTS

Oil, Butter, Salt etc.

Various types of soiling - sensitive to specific products

Rust, Chewing-gum, Mildew

Chemical soiling - sensitive to specific products

Ink, Mercury-Chrome, Deodorants, Paints



3.4 Mechanical action

The mechanical action of the appliance is produced by the combination of clockwise/anti-clockwise rotation of the drum, which agitates the wash load in the washing solution. This action tends to transfer the dirt from the fabrics to the washing solution (water + chemical products).

The mechanical action may be VIGOROUS or DELICATE:

- Vigorous drum movement in alternating directions (clockwise and anti-clockwise) is suitable for cotton and polyester fabrics.
- Delicate drum movement in alternating directions (clockwise and anti-clockwise) is suitable for wool and delicate fibres.

3.5 Duration of the washing cycle

Each washing cycle requires a minimum duration in order to guarantee satisfactory results. The duration of the cycle depends on the type of fabric, the type of soiling and the quantity of washing in the drum.

3.6 Water

Water is the most important element in the washing process, and is fundamental to the final result. Ideally, the water used for the wash should have the following composition:

- Clear and transparent, a low level of hardness, absence of manganese, low iron and mineral salt content.

The water may contain various substances (mineral and others) in varying quantities:

- Fe (iron), Mg (manganese), Si (silicon), Na (sodium), Ca (calcium), K (potassium).

Some of these substances, if they exceed a certain level or are present in combination, may lead to the formation of ferrous oxide, which causes the well-known phenomenon of "rust spots".

In addition, if present in excessive quantities in the water, some substances may react with the chemicals contained in the detergent, altering its characteristics and preventing it from performing with full efficiency.

During the heating phase, calcium and manganese - if present in excessive quantities - react at temperatures in excess of 60°C, producing calcareous substances that, suspended in the washing solution, may adhere to the fabrics.

These calcareous substances may precipitate, forming a scale build-up on the internal components of the appliance (tub, heating element, filter body etc.).

3.6.1 Formation of lime scale and ferrous oxide

As rain falls through the atmosphere, it dissolves the gases that it contains: when it comes into contact with carbon dioxide, the rain absorbs the gas and transforms it into droplets of dilute carbonic acid ($H_2O + CO_2 = H_2CO_3$).

When the carbonic acid falls onto calcareous rocks, it reacts with the limestone to form a solution of Calcium bicarbonate ($Ca(HCO_3)_2$).

The problems of rust spots deposited on the washing are due mainly to the presence of ferrous oxide in the water. It is difficult to determine the quantity of ferrous oxide originally present in the water and the quantity that forms by reaction. If a filter with a very fine mesh is installed on the tap supplying the appliance, ferrous residue will be deposited after only a few days. This is one of the major obstacles to achieving a satisfactory washing result.

3.6.2 Hardness of the water

According to current conventions, the hardness of the water refers to the concentration of calcium and magnesium ions. In general, a distinction is made between total hardness, permanent hardness, temporary hardness, alkaline (carbonate) and non-alkaline hardness.

The total hardness indicates the concentration of calcium and magnesium, while the temporary hardness refers only to magnesium and calcium bicarbonate, which precipitate when the water boils.

Permanent hardness is caused by all the salts which, after boiling, do not precipitate in the same way as carbonates, but instead remain suspended in the solution (thus including sulphates, chlorides and calcium and magnesium nitrates).

The alkaline (or carbonate) hardness refers to soluble bicarbonates, hydroxides and carbonates. The excess hardness with respect to the alkaline hardness is referred to as the non-alkaline (non-carbonate) hardness.

The hardness of the water is caused by soluble calcium (Ca) and magnesium (Mg) salts, expressed as calcium carbonate, measured in "°F", and calcium oxide, which is measured in "°D".

From a toxicological viewpoint, hard water does not appear to be harmful to human beings. On the contrary, it has been observed that the presence of calcium and magnesium helps to prevent certain illnesses such as hypertension and cardiac arrest.

However, at an industrial level, hard water may cause scale to form on mechanical parts due to the presence of carbonates, sulphates and alkaline-ferrous metal silicates. This scale build-up can significantly reduce the efficiency of a machine. Especially at risk are components such as heat exchangers, boilers, domestic appliances (washing machines, dishwashers etc.), because the reaction is endothermic. In other words, the formation of carbonates is facilitated by an increase in temperature. In the dyeing industry, calcium and magnesium may cause certain colouring agents to precipitate, thus causing uneven distribution of the colour on the fabrics.

3.6.3 Total water hardness

Total hardness is the sum of the temporary hardness (caused by calcium and magnesium bicarbonates) and the permanent hardness (caused by sulphates, chlorides and calcium/magnesium nitrates).

- Hardness expressed in French degrees (°F) represents the quantity of calcium carbonate, in grammes, contained in 100 litres of water.
- Hardness expressed in German degrees (°D) represents the quantity of calcium oxide, again in grammes per 100 litres of water.

Conversion of °F - °D:

$$1\text{ °D} = 1,79\text{ °F}$$

$$1\text{ °F} = 0,56\text{ °D}$$

Classification of total water hardness expressed in °F and °D

	°F	°D
<i>SOFT</i>	0 – 14	0 - 7
<i>AVERAGE HARDNESS</i>	15 – 26	7 - 14
<i>HARD</i>	27 – 39	14 - 21
<i>VERY HARD</i>	> 40	> 21

Negative effects of hard water:

- Reduction in the effectiveness of anionic surface-active agents.
- Increase in the quantity of dirt re-deposited.
- Increase of residue deposited on the fabrics.
- Increase of scale formation on the heating elements.

Hard water may cause the formation of incrustation on mechanical parts, due to the presence of carbonates, sulphates and alkaline-terrous metal silicates. This may also lead to a considerable reduction in the efficiency of the appliance, since the reaction is endothermic; in other words, the increase in temperature favours the formation of carbonates.

The most important of the soluble salts present in water are calcium bicarbonate and magnesium bicarbonate. When the water is heated to over 60°C, these react and precipitate to form limescale (which deposits on the fabrics and causes stiffness).

Water softening mechanisms

Hard water can be softened in three ways:

SEQUESTRATION: soluble compounds such as TPF, polycarboxylics, citrates

PRECIPITATION: insoluble compounds such as soaps, sodium carbonate

ION EXCHANGE: insoluble compounds such as zeolites, lamellar silicates.

Water softeners are used only for washing temperatures in excess of 60°C, i.e. when the high temperature causes the calcium to precipitate.

3.7 Detergents

Modern detergents are less aggressive than those used in the past, partly for reasons of environmental protection and partly to prevent damaging the fibres. If used correctly, these offer an excellent protective treatment and a high level of washing power.

Detergents that contain no phosphates are far more sensitive to the reaction with calcium. When the door of a washing machine is opened, the user will immediately observe that the interior is clean and shiny if high-quality detergents have been used.

3.7.1 Composition of a detergent

- SURFACE-ACTIVE AGENTS (soap and active washing substances)
- ZEOLITES (water softeners)
- ALKALIS
- BLEACHING AGENTS
- OPTICAL WHITENERS
- OTHERS: Enzymes, stabilizing agents, CMC, colouring agents, perfumed essences, TAED, PVP, lipase, protease.



3.7.2 Functions of the principal components of a detergent

1. SOAP: A detergent that is soluble in water, composed of sodium or potassium salts, fatty acids (such as oleic or stearic). The main function of soap is to dissolve grease. During the washing cycle, the grease precipitates, creating insoluble calcium (Ca) and magnesium (Mg) salts which, if present in excessive quantities, tend to become attached to the fabrics (black balls).
2. SURFACE-ACTIVE AGENTS: synthetic substances with wetting and detergent properties, and able to reduce the surface tension thus facilitating the penetration of the washing solution into the fabrics to dissolve the dirt. These agents disperse and emulsify the dirt and grease, which are then held in suspension in the washing solution.
3. SILICATES: alkaline substances that improve the washing result, protecting the fabrics or dishes and the appliance itself from corrosion. Not aggressive to the skin.
4. ANTI-FOAM (regulator): the correct quantity of foam is necessary for the effectiveness of the mechanical action, and therefore influences the intensity of the wash (large quantities of foam reduce the mechanical action and vice versa). Anionic surface-active agents generally increase the quantity of foam.
5. ZEOLITES: Zeolite is an insoluble solid that absorbs or fixes calcium ions, replacing them with sodium ions (to reduce hardness), thus increasing the effectiveness of the detergent.
6. ALKALIS: alkalis make the washing solution alkaline, increasing the washing power and swelling the fibres so that the dirt is dissolved more easily. In addition, alkalis help to remove scale build-up from the appliance.
7. BLEACHES: bleaches are generally perborates (substances that generate active oxygen). Active oxygen is released during the washing phase between 60°C and 90°C, and requires the presence of stabilizers to ensure uniform action. The oxidizing power of the active oxygen released eliminates substances that stain the fibres.
8. OPTIC WHITENERS (also known as blueing agents): optic whiteners are organic chemical substances that can transform ultraviolet light into visible "BLUE" light (yellow + blue = white).

3.7.3 Functions of other components of a detergent

1. **ENZYMES:** Enzymes are proteins produced by living cells (animal and vegetable) and are able to transform organic materials with a high molecular weight, such as starches, proteins and fats, into more easily soluble products. These integrate with and facilitate the action of the detergent, eliminating protein-based dirt. Their direct action also facilitates the removal of other types of dirt. In order to give positive results, enzymatic products must be used at temperatures between 40°C and 60°C (maximum).

At higher temperatures, the proteins contained in the enzymes (which are temperature-labile) are vulnerable to denaturing. Denaturation causes irreversible alterations in the structure, leading to the loss of the enzymatic action.

Protease - which is present in enzymatic detergents - is equally active in the presence of fresh and old proteins alike.

Enzymatic detergents are especially active in both the pre-wash phase and in separate soak cycles.

In all soak processes, products containing enzymes able to dissociate the proteins improve the results of the wash considerably. In addition, enzymes vertically break down scale incrustations deposited on the appliance, thus helping to detach the alkalis present in the detergent.

2. **STABILIZING AGENTS:** These are chemical products designed to control the uniformity of the bleach by stabilizing the washing solution.
3. **CMC:** CMC is used to hold the dirt in suspension so that dirt particles are not re-deposited on the fabrics.
4. **COLOURING AGENTS:** These serve exclusively to make the product more attractive to the eye.
5. **PERFUMED ESSENCES:** Give the washing a pleasant fragrance.
6. **TAED:** TAED reacts with the perborate to form peracetic acid, which has strong bleaching and disinfectant properties even at low temperatures (reacting from a temperature of just 30°C). However, if the TAED content is excessive, coloured fabrics may fade. By itself, perborate reacts at temperatures in excess of 60°C, while perborate with TAED begins to react at 30°C.
7. **PVP:** An ingredient that prevents colour transfer.
8. **LIPASE:** Chemical substances (enzymes) that dissolve fats by hydrolyzation.
9. **PROTEASE:** Chemical substances that destroy proteins (casein, albumin, gelatin, blood protein, perspiration, food residue, fruit juice). These release albumin molecules, which become soluble in water.

3.7.4 Detergent quantities

- efficiency of the washing programme according to the load and the water hardness.

In order to perform its function completely and correctly, the appropriate quantity of detergent must be used, which depends on the quantity of water that is contained in the tub of the washing machine, the type of washing cycle, the type of fabrics, the type of soiling and the quantity of washing in the drum.

Small quantities of detergent will be insufficient for efficient washing. But excessive quantities of detergent will cause yellowing of the fabrics, since the final rinse will not be sufficient to remove all the excess detergent, traces of which will remain on the fabrics.

The detergent properties of the soap are considerably reduced when the water is hard. The harder the water, the greater is the possibility that calcareous soap will precipitate: **1 gramme of calcium bonds to 16 grammes of soap**, thus making the soap ineffective and reducing the washing power significantly.

The combination of calcareous soap forms lumps of fat which remain attached to the dirt. This fatty substance tends to deposit on the edges of the sink, on the bathtub and on the seals of the washing machine. It also deposits easily on the fabrics, turning them a greyish colour (stains); in addition, it considerably reduces the capacity of the fabrics for absorption.

The hardness of the water not only reduces the washing power of the detergent, but also reduces the softness, resistance and whiteness of the fabrics washed.

When hardening agents such as Ca (calcium) and Mg (magnesium) react with certain components of the detergent, the fabrics may become encrusted (calcium and detergent deposits) after a number of washes. These give the fabrics a greyish colour and make them rough to the touch, as well as reducing their capacity for absorption significantly. This phenomenon is especially noticeable in the case of terrycloth garments (shower robes, towels etc.), causing them to lose their particular properties and to wear out faster.

Quantities recommended by the producers

- Normal/concentrated detergent: 150 - 300 g. / 15 g. per 15l. H₂O
- *Obviously, appliances designed with reduced consumption in mind (energy label) and belonging to energy classes A, B, C and D are designed to wash using up to 50% less detergent than other appliances.*

Powder detergents	
PRE-WASH DETERGENTS:	→ WITH ENZYMES
COMPLETE DETERGENTS:	→ REDUCED-FOAM → EXTRA-FOAM (for hand washing)
SPECIAL DETERGENTS:	→ FOR DELICATE FABRICS AND WOOL → FOR COLOURED FABRICS

Liquid detergents
→ FOR HDLD COLOUR-FAST COLOURED
→ FOR SYNTHETIC FIBRES
→ LDLD FOR LOW-TEMPERATURE WASHING (DELICATES)
→ FOR WOOL AND DELICATE SYNTHETIC FIBRES
→ FOR HEAVY-DUTY HAND- OR MACHINE WASHING
→ FOR PRE-TREATMENT OF PERSISTENT STAINS

Compact detergents
→ EXCELLENT FOR ALL WASHES - THE QUANTITY DEPENDS ON THE BRAND

3.7.5 Washing additives

1. **SOFTENER:** (Cationic surface-active agent + fragrance): This additive is introduced automatically by the appliance during the final rinse. It softens the surface of the fabric, which thus remains soft to the touch and easier to iron. If used incorrectly before or during the wash, or if introduced too early into the tub by the water fill system, its action is rendered ineffective by the surface-active agents contained in the detergent.
2. **BLEACH:** (sodium hypochlorite) - Used for white fabrics, before the main wash cycle. 150 ml of bleach will be sufficient for a short, low-temperature wash. Care should be taken when bleaching: certain stains (blood, perspiration), if bleached before the enzyme-based function, may become permanently fixed to the fabric, giving an unsatisfactory washing result. In normal washes, the bleach must be introduced automatically by the washing machine during the first rinse, at the end of the washing phase and after the detergent has performed its functions, since it destroys the enzymes contained in the detergent. If the stains have already become permanent after a previous wash, they will be impossible to remove.
3. **DELICATE BLEACH** (hydrogen peroxide) - Oxygen is not as strong as chloride, especially if the water is very hard. It must always be used together with the detergent, both for hand washing and when using a washing machine. It may be used for pre-treatment, but always followed by a wash using detergent. It may be used at all temperatures and during the wash (together with detergent), or poured directly onto the fabrics.

3.7.6 Bleaching

Bleaching is generally performed after the wash (by hand or in a machine), except in the case of wine, tea or coffee stains etc.

Light-sensitive stains (tomato etc.), if appearing on the fabrics after the wash, may disappear when the fabric is exposed to sunlight for a time (action of the sun's rays).

If a white fabric is treated with a bleach and then exposed to sunlight, the optical effect may be cancelled, and yellowish stains may become noticeable. However, these will tend to disappear when the garment is no longer exposed to the sun.

Using bleaches

Various types of bleach exist to suit different conditions of use, since they remain active either within or in excess of certain temperatures.

- Hypochlorite: must always be used cold (during the 1st rinse)
- Peroxide: may be used above 60° during the washing phase
- Delicate bleach (solid): a teaspoonful should be added to the detergent. Suitable for all types of fabrics, including coloureds. Active at medium and high temperatures.
- Delicate bleach (liquid, i.e. hydrogen peroxide) should be introduced into the appropriate compartment.
- Active perborate: active at temperatures in excess of 60°C.

N.B. If hydrogen peroxide or sodium hypochlorite are used for bleaching, or in the presence of "activators" attached to the garments (ferrous accessories such as buttons, buckles, zips, hooks etc.), these may cause holes in the fabric or stiffness of the fibres due to re-deposited oxides which form the well-known "rust spots".

3.8 The function of the water temperature

The variety and quality of natural and synthetic fibres which comprise the fabrics, which are sometimes present in percentages that are not declared correctly on the labels, make it necessary in many cases to use a detergent whose washing action is effective at low temperatures. As a result, the consumer today tends to use washing programmes with a maximum temperature of about 60°C, partly due to increasing sensitivity to energy savings.

Manufacturers of detergents, in line with this trend, have modified the quality of their products to meet this need, and frequently emphasize these characteristics in their promotional activities.

- Temperature helps to dissolve the dirt (solvent effect)
- Temperature facilitates and accelerates the chemical reactions, especially when bleaching.

The "**CORRECT**" temperature in the various phases of the washing cycle:

- reduces the cohesion of the dirt
- facilitates the suspension of the dirt in the water
- facilitates the reaction of the alkalis (swelling the fabrics so that the dirt is dissolved more easily)

High temperatures do not facilitate the removal of all types of dirt; in fact, blood, egg-yolk, milk etc. are more easily removed if washed in cold water; if hot water is used, these stains adhere more strongly to the fibres and become more difficult to remove.

3.8.1 Using the correct temperature

The temperature of the washing solution is used to remove the dirt and to ensure hygiene.

HIGH TEMPERATURE = 80 - 90°C

Suitable for difficult soiling: cotton and linen (whites) with bleach, perborate and hydrogen peroxide.

AVERAGE TEMPERATURE = 50 - 60°C (most washing cycles)

Suitable for washing colour-fast fabrics: cotton and linen (coloured) with hypochlorite-Based bleaches.

LOW TEMPERATURE = 30 - 40°C

Suitable for washing wool, synthetic fabrics, other delicate fibres, and for soaking of fabrics soiled with blood or protein-based substances.

3.9 Washing machine programmes

<p>Pre-wash (not for wool and, in some cases, delicate fabrics)</p>	<ol style="list-style-type: none"> 1. Water fill with detergent introduced from the pre-wash compartment 2. Brief heating phase and hot wash (30 - 40°C) 3. Drain 4. (Brief spin)
<p>Wash</p>	<ol style="list-style-type: none"> 1. Water fill with detergent introduced from the wash compartment 2. Heating and hot wash <ul style="list-style-type: none"> - 30÷90°C for cotton and linen - 30÷60°C for synthetic fibres - 30÷40°C for wool, silk and delicate fabrics 3. Maintenance phase (mechanical action after the heating phase) 4. Cooling water fill (in cotton cycles, reduces the temperature of the drain water, in synthetic cycles as an anti-crease cycle) 5. Drain 6. Brief spin (cotton/linen only)
<p>1st rinse</p>	<ol style="list-style-type: none"> 1. Water fill (and, if selected, introduction of bleach for cotton/linen only) 2. Cold wash 3. Drain 4. Brief intermediate spin (if selected - cotton/linen only)
<p>2nd (3rd) rinse</p>	<ol style="list-style-type: none"> 1. Water fill 2. Cold wash 3. Drain 4. Brief intermediate spin (if selected - cotton/linen only)
<p>Final rinse (softener)</p>	<ol style="list-style-type: none"> 1. Water fill to softener compartment 2. Cold wash
<p>(Rinse-hold)</p>	<ol style="list-style-type: none"> 1. In cotton/linen cycles, the programme generally passes to the subsequent phase; it stops with water in the tub (rinse-hold) only if this function has been selected (certain models only) 2. The cycle generally stops with water in the tub (rinse-hold) for synthetic, delicates and wool cycles if there is no rinse-hold button or selector. If these are featured (rinse-hold, delicate spin, anti-crease etc.), the cycle may stop or pass to the subsequent phase according to the option selected.
<p>Final spin</p>	<ol style="list-style-type: none"> 1. Drain 2. Final spin <ul style="list-style-type: none"> - at maximum speed for cotton/linen - brief and at reduced speed for synthetics, delicates and wool (certain models only)
<p>STOP</p>	

3.10 Control panel

The plastic control panel is secured to the control panel support by anchor tabs and one or more screws. The shape of the control panel depends on the styling, with LCD display, with DISPLAY or without.

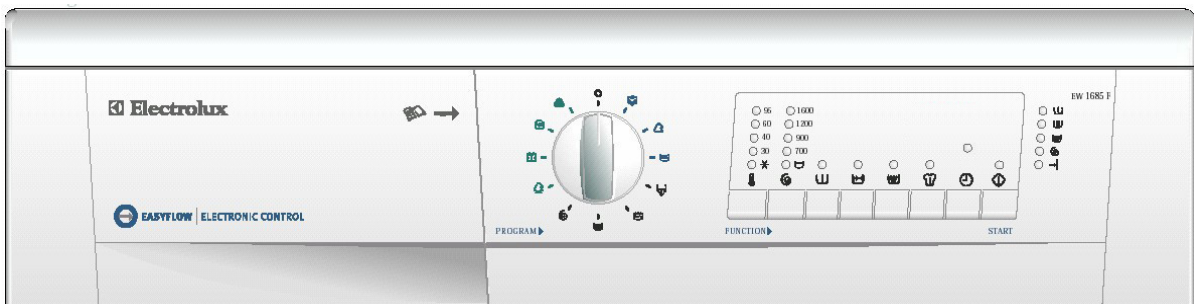
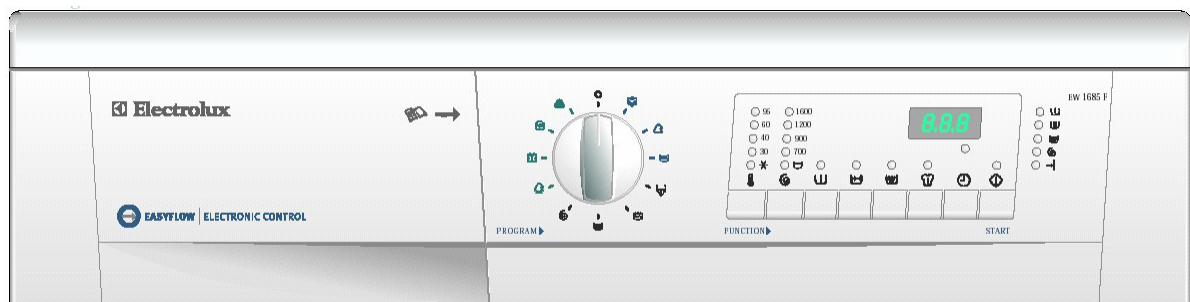
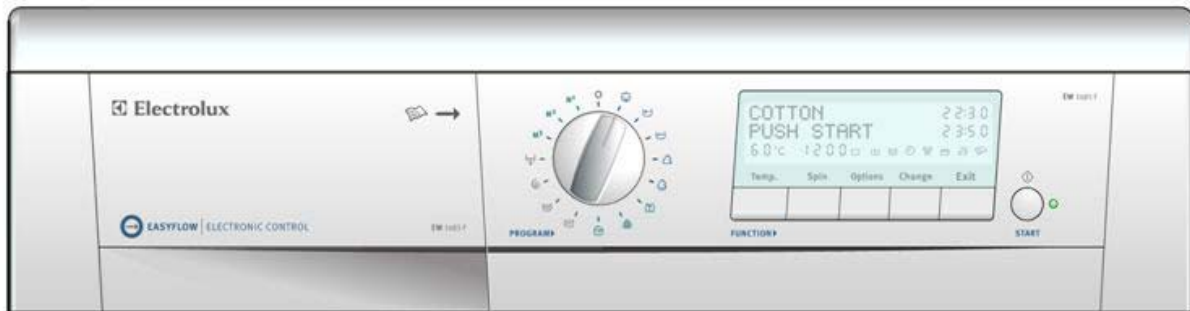

3.11 "JETSYSTEM" washing system

- In the "Jetsystem" washing system, considering that the removal of the dirt is performed solely by the water that passes through the fibres, the remaining part of the washing solution has been eliminated.
 - In other words, this system is based on the possibility of washing the fabrics using only the water used to wet them; the quantity of water introduced into the appliance is therefore proportional to the type and quantity of the fabrics in the drum.
 - The water is introduced by the solenoid valve; its level is controlled by a pressure switch.
 - The water present in the bottom of the tub is circulated by a pump, which ducts it to the fabrics through an aperture in the bellows seal.
- ↗ The mechanical action is provided by the bi-directional rotation of the drum at low speed; the wash load is continuously rotated inside the drum by three drum lifters.

3.11.1 Jetsystem "DIRECT SPRAY" washing system

1. Water fill solenoid
2. Detergent dispenser
3. Tube from detergent dispenser to tub
4. Tub
5. Drum
6. Drum lifter
7. Tube between tub and filter body
8. Filter body
9. Tube between filter body/circulation pump
10. Circulation pump
11. Circulation tube
12. Door seal
13. Heating element with NTC incorporated
15. Drain pump

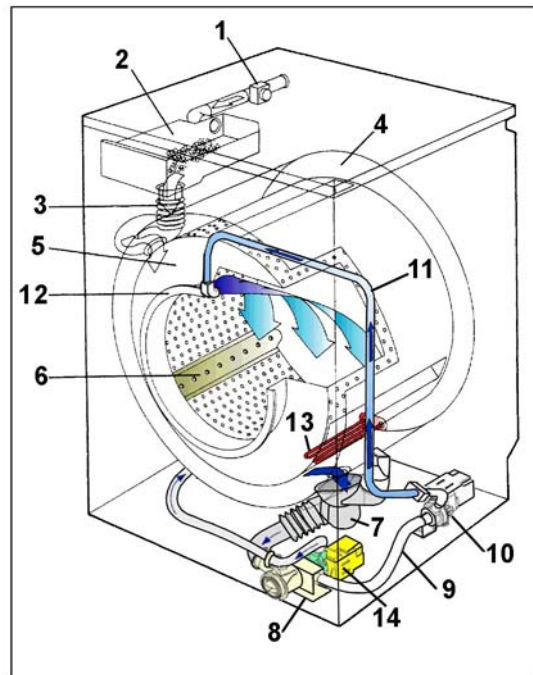

4 STRUCTURAL CHARACTERISTICS

4.1 "NEXUS" technology

These appliances are produced using the NEXUS technology, a patented system consisting of five sub-assemblies:

- Base
- Cabinet
- Control panel support
- Washing group
- Work-top

1. Base
2. Damper
3. Rear cabinet
4. Washing group
5. Suspension spring
6. Conveyor
7. Work-top
8. Control panel support
9. Front cabinet
10. Control panel
11. Detergent drawer
12. Door

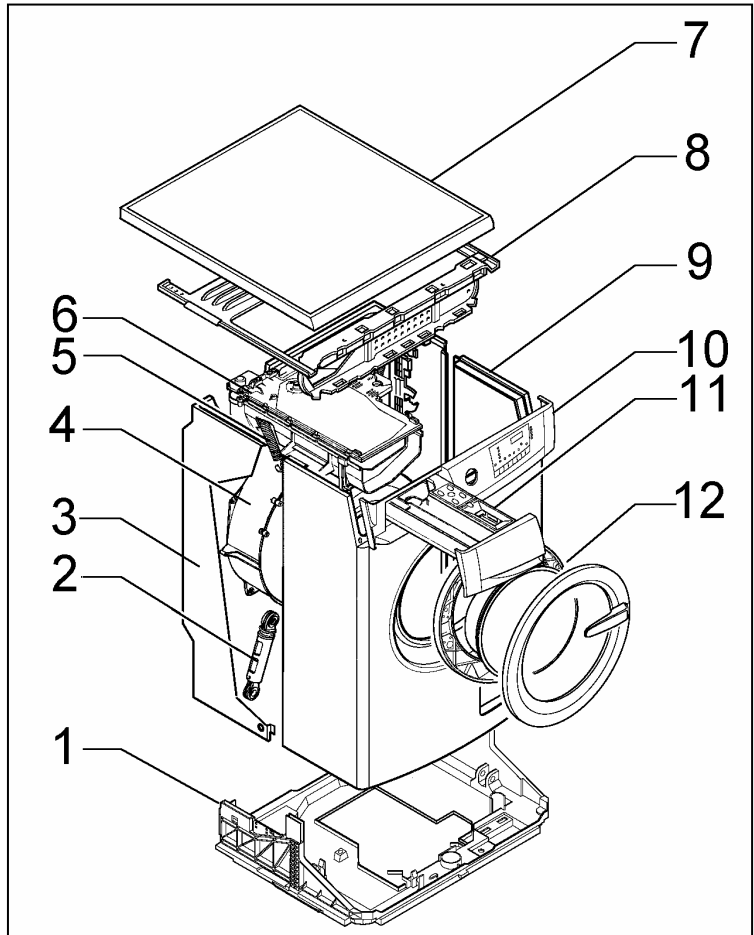

4.2 Base

1. Base
2. Filter body
3. Drain pump
4. Circulation pump
5. Dampers
6. Inverter (only some models)

The base is built in "CARBORAN", a specially-developed plastic.

As well as the two cabinet shells, the filter body, drain pump, dampers and (if featured) the circulation pump and motor control system are all housed in the base (inverter).

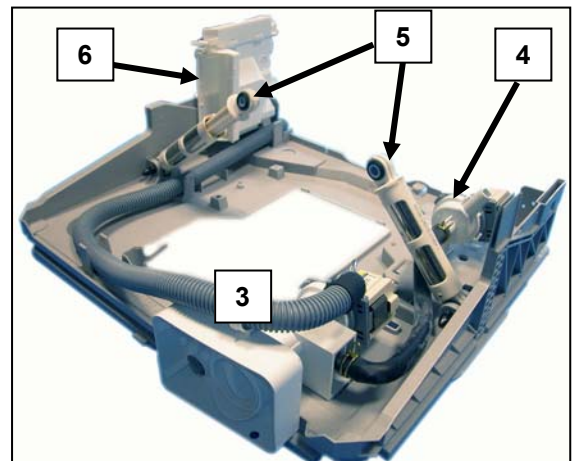

4.3 Control panel support

1. Selector
2. Electronic board
3. Pressure switches
4. Detergent dispenser

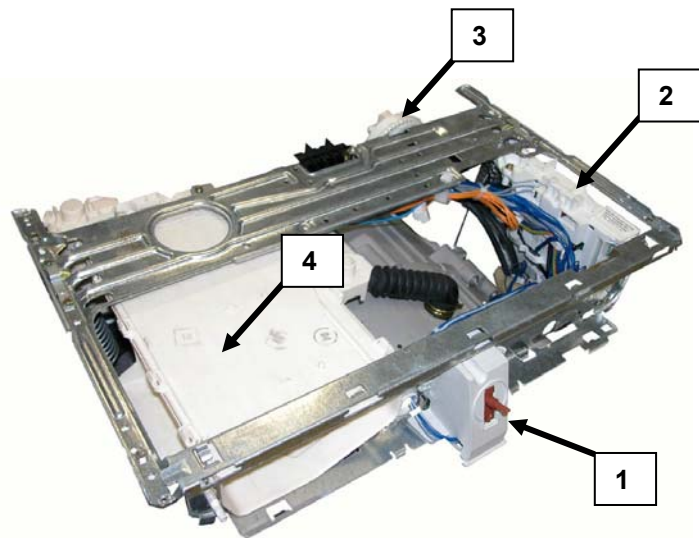

The control panel support (in galvanized sheet metal) is secured by a series of screws to the two cabinet shells.

Several components are fitted to the support: electronic board, pushbuttons, switch, capacitor, pressure switches, detergent dispenser and control panel.

Also secured to the support are the two suspension springs for the washing group.

RIM (dimensions 85x60x60)	
With or without DISPLAY	With LCD

4.4 Cabinet

The cabinet consists of two half-shells in enamelled sheet metal, which are secured to a Carboran base. The support cross-member (in galvanized sheet metal) is screwed to the upper section of the cabinet. The work-top is screwed to the rear section of the cabinet shell.

4.5 Door

Door characteristics:

- large 30 cm
- angle of aperture 160° and 180°
- alignment with front panel
- differently-styled surrounds
- type of aperture (various handles)



1. Front surround
2. Door glass
3. Rear surround
4. Hinge
5. Handle
6. Handle spring
7. Pin
8. Latch
9. Latch spring
10. Flange

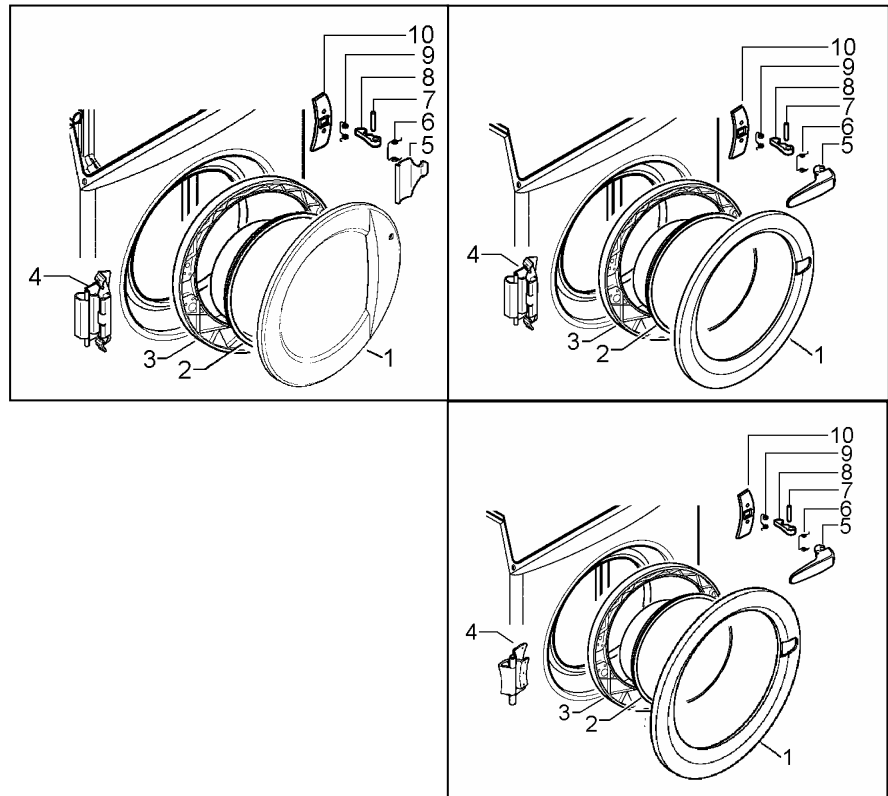

4.5.1.1 Handle assembly

1. Handle
2. Hinge pin
3. Latch
4. Latch spring
5. Handle spring (certain models only)

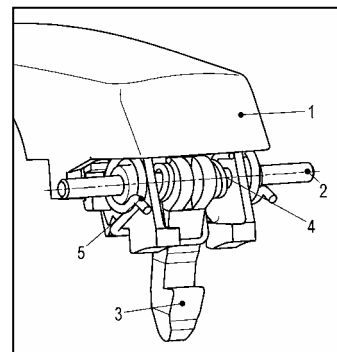

4.6 Washing groups

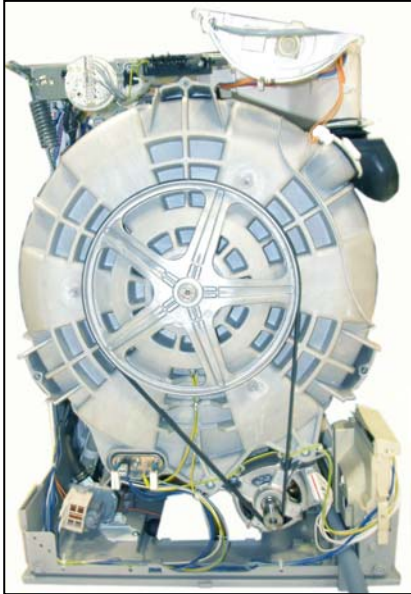

The washing group is suspended from the support cross-member by two helical springs. The oscillation of the washing group is absorbed by the two dampers attached to the base. Balancing of the washing group is provided by a front counterweight in cement.

4.6.1 Damper

1. *Rubber vibration damper*
2. *Shaft*
3. *Shaft seals*
4. *Cylinder*
5. *Rubber vibration damper*

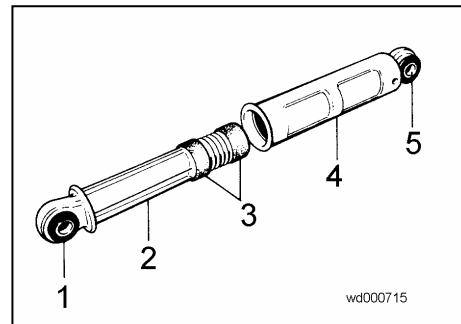

4.6.2 Washing group in Carboran

The tub consists of two half-shells in Carboran, secured together by a series of self-tapping screws. The two counterweights are screwed to the half-shells. The bellows seal is secured to the front half-shell by a metal elastic ring.



1. Front half-shell
 2. O-ring
 3. Rear half-shell
 4. Drum
 5. Front counterweight
 6. Counterweight anchor screw
 7. Bellows seal
 8. Ring securing the seal to the tub
 9. Ring securing the seal to the cabinet
 10. Rear counterweight
 11. Washing group suspension springs
 12. Damper
 13. Damper hinge pin
- Half-shell anchor screws

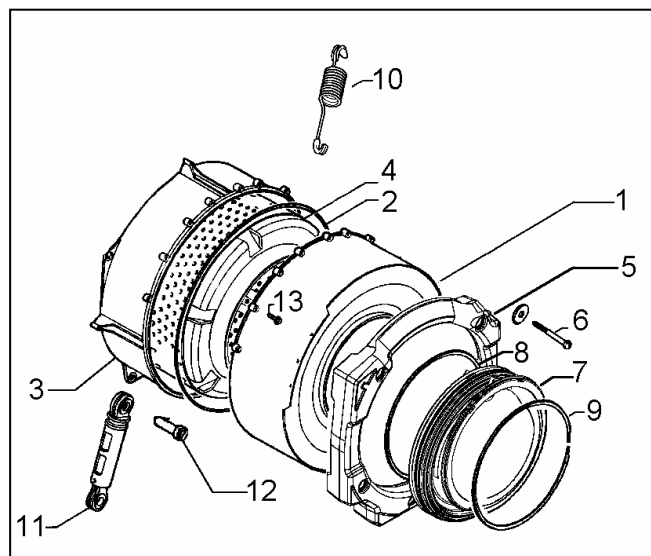

4.6.2.1 Support for bearings

1. Rear tub shell
2. Bearing support
3. Drum shaft
4. External bearing
5. Internal bearing
6. Drum shaft bushing
7. Drum shaft seal
8. Drum

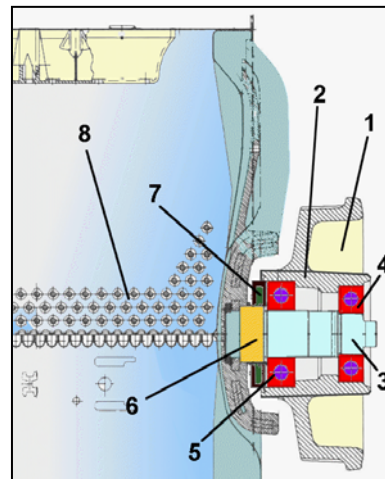

4.6.3 Drum

The drum consists of a stainless steel casing to which the two flanges are crimped. Three Carboran lifters are pressure-fitted to the internal face of the drum. The drum spider, in aluminium alloy, is secured to the edge of the drum by screws. A brass bushing is pressure-fitted to the drum shaft.



1. Drum casing
2. Flange
3. Drum lifter
4. Drum spider
5. Screws
6. Drum shaft
7. Drum shaft bushing

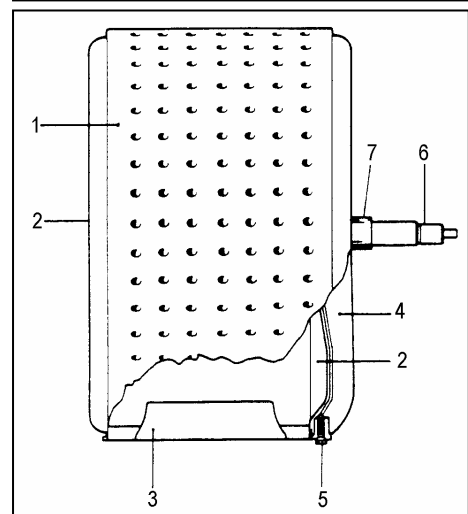

Drum spider



4.6.4 Drum rotation drive belt

These appliances are fitted with elastic drive belts. The motor is mounted in a fixed position, and no regulation is possible.

1. Motor pulley
2. Elastic drive belt
3. Drum pulley

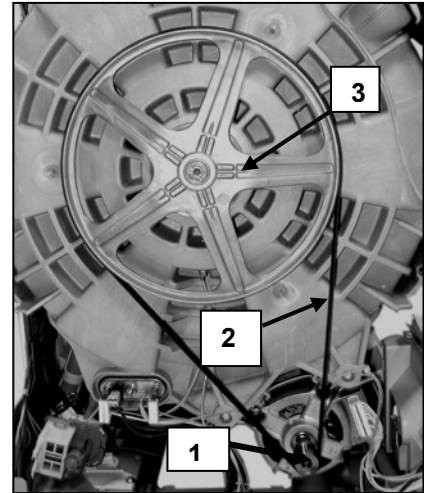

Different types of drive belts, produced by various manufacturers and with different characteristics, are used in production:

- rubber belts (black)
- plastic belts (yellow)

The length marked on the drive belt (1217, 1280 etc.) is the working length based on the belt mounted on the pulleys, which is calculated according to the following parameters:

- $\varnothing D$ = diameter of drum pulley
- $\varnothing de$ = diameter of motor pulley
- l = centre-line distance between the pulleys

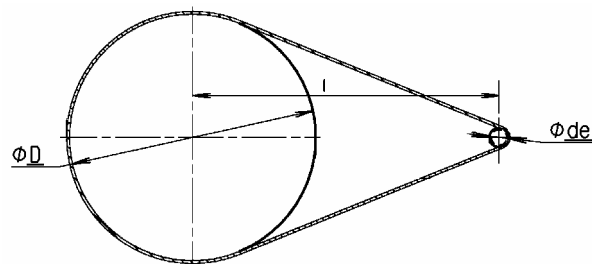

For a given working length, the belts - which consist of different materials - have a different degree of elasticity. This means that, when not fitted to the appliance, their lengths may be different. It is normal that the length of a plastic belt not fitted to the pulleys is three or four centimetres greater than that of a rubber belt.

The belts are of the poly-V type, and are marked with two further parameters:

- shape of the drive belt (J / H)
- number of teeth (4, 5, 6, 8)

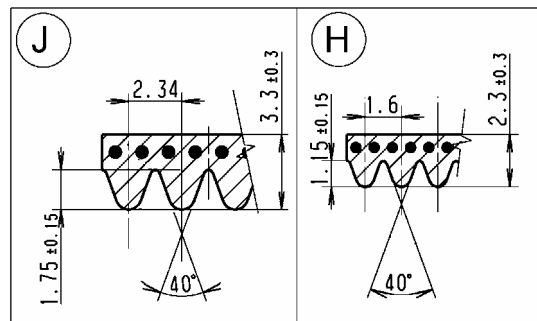

4.7 Detergent dispenser

4.7.1 Detergent dispenser with multiple-outlet solenoid valve

This type of detergent dispenser, in different dimensions, is used in models featuring:

- EWM1000 electronic control system
- EWM2000EVO electronic control system
- EWM3000NEW electronic control system

The water is ducted into the detergent compartment by a solenoid valve with one inlet and 2 or 3 outlets. The detergent drawer may consist of 3 or 4 compartments.

1. Fill hose
2. Seal
3. Solenoid valve support
4. Cable clamp
5. Water fill solenoid (cold)
6. Hose
7. Dispenser nozzle
8. Dispenser conveyor
9. Steam exhaust hose
10. Additive syphon
11. Detergent drawer
12. Clamp
13. Detergent fill hose

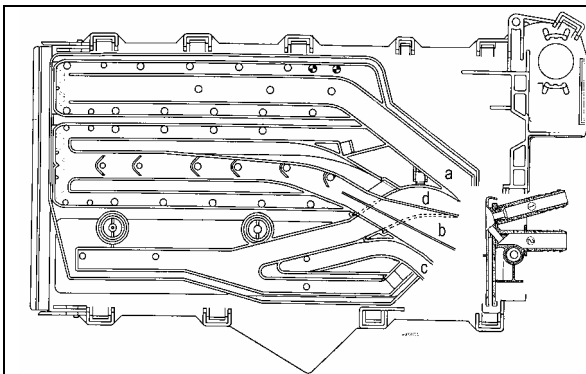
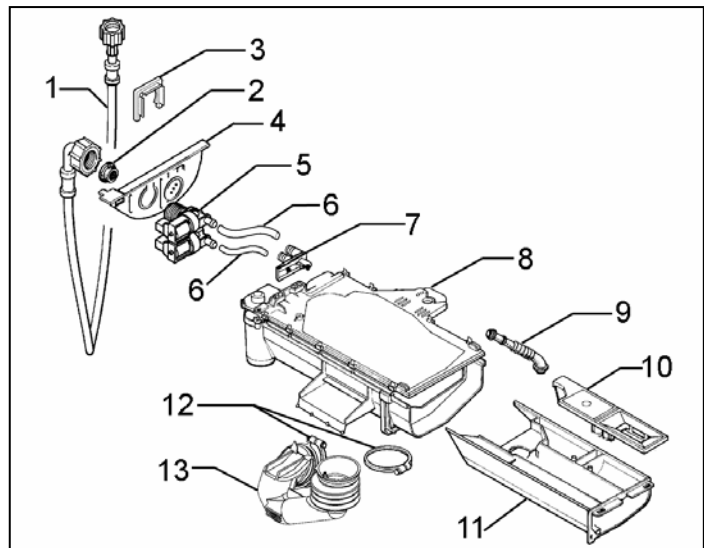

- Water duct with four compartments
- 2- or 3-way water inlet nozzle
- 3- or 4-compartment detergent drawer

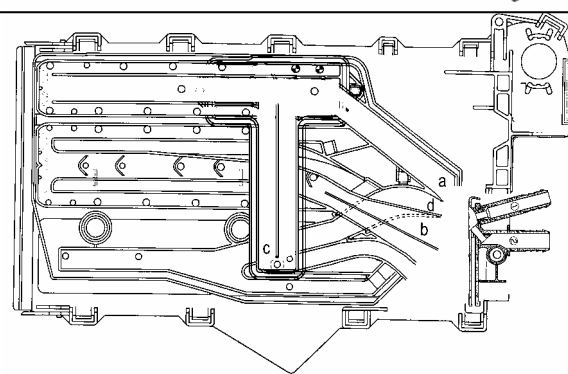

- Water duct with four compartments and flow deviator
- 2-way water inlet nozzle
- 4-compartment detergent drawer

Combinations of solenoid valves

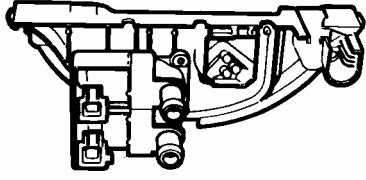
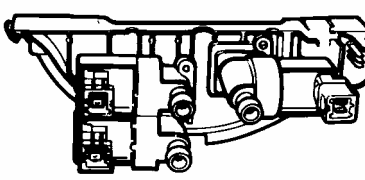
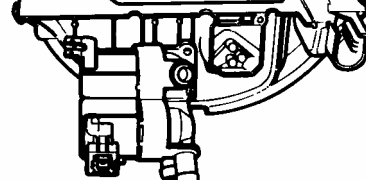
2-way solenoid valve	2-way solenoid valve + solenoid valve for introduction of hot water	3-way solenoid valve
		

4.7.1.1 Principles of operation

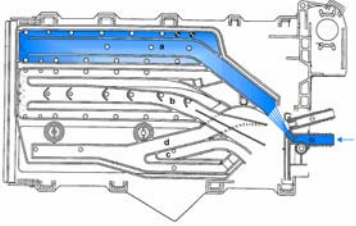
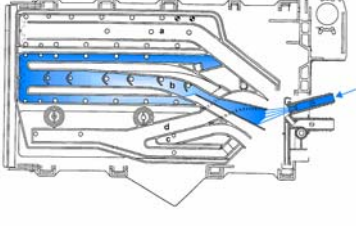
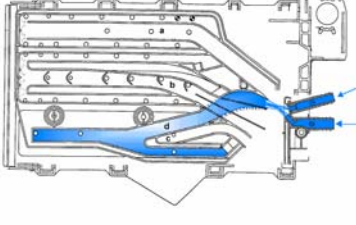
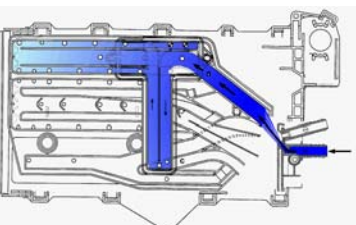
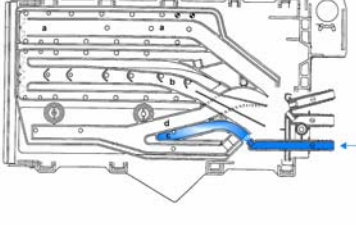
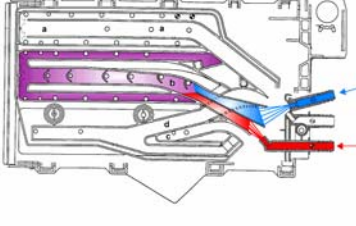
<p style="text-align: center;">Water fill to pre-wash compartment (Pre-wash solenoid valve)</p> <ul style="list-style-type: none"> This version is used in models with three compartments (EWM1000) and 3 or 4 compartments (EWM2000EVO/EWM3000NEW). The detergent contained in compartment "a" is introduced at the beginning of the pre-wash phase. In certain models featuring the "stains" option, compartment "a" may be used (as an alternative) to contain the stain-removal product, which is introduced during the wash phase. 	
<p style="text-align: center;">Water fill to wash compartment (Washing solenoid valve)</p> <ul style="list-style-type: none"> In all models, compartment "b" is used to contain the detergent, which is introduced at the beginning of the wash phase. 	
<p style="text-align: center;">Water fill to conditioner compartment (pre-wash and wash solenoid valves)</p> <ul style="list-style-type: none"> In all models, compartment "d" is used to contain the conditioner, which is introduced at the beginning of the final rinse. 	
<p style="text-align: center;">Water fill to pre-wash and bleach compartment (Pre-wash solenoid valve)</p> <ul style="list-style-type: none"> In EWM1000 models with 4-compartment detergent dispensers, water is ducted into compartments "a" and "c", though not at the same time. <p>1. If the user selects the pre-wash option, water is ducted through compartments "a" and "c" at the beginning of the pre-wash phase. If this option has not been selected, water is ducted through the compartments at the beginning of the first rinse.</p>	
<p style="text-align: center;">Water fill to bleach compartment (Bleach solenoid valve)</p> <ul style="list-style-type: none"> In EWM2000EVO/EWM3000NEW models with 4 compartments, water is ducted through compartment "c" at the beginning of the final rinse. 	
<p style="text-align: center;">Hot water fill (Wash + hot water solenoid valve)</p> <p>1. In models featuring the hot water solenoid valve (EWM2000EVO/EWM3000NEW only), the wash and hot water solenoid valves are actioned simultaneously to duct mixed water (hot and cold) through the wash compartment.</p>	

4.8 "NEW JET" circulation circuit

1. Tube between tub and filter body
2. Filter body
3. Drain filter
4. Washer
5. Filter knob
6. Drain pump
7. Pump cover
8. Circulation pump intake tube
9. Circulation pump
10. Pump cover
11. Circulation tube
12. Pressure chamber

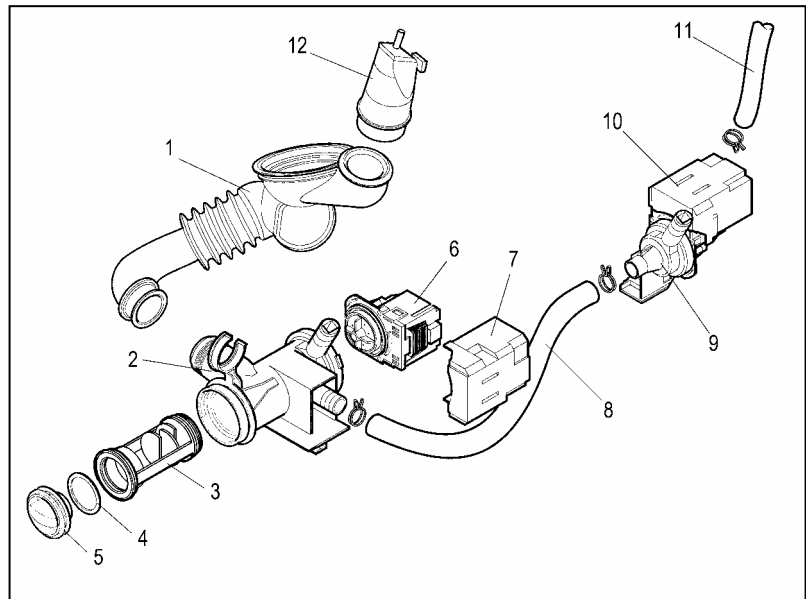

Drain filter

- This drain system is self-cleaning: the filter traps only objects of a certain size.
- The drain tube is used to empty the drain circuit.
- The pump impeller can be inspected after unscrewing the filter.

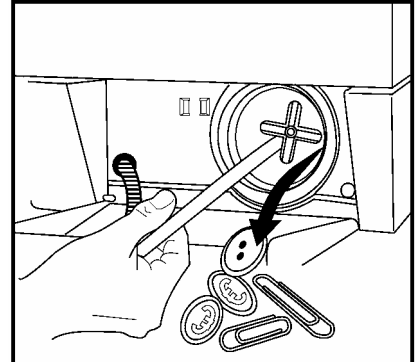
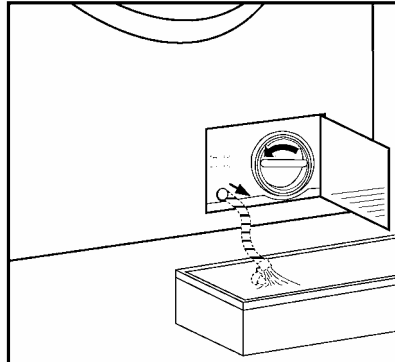
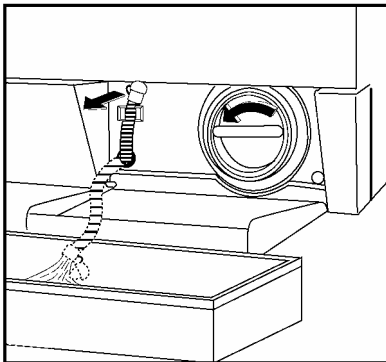

5 ELECTRICAL COMPONENTS

5.1 Suppressor

5.1.1 General characteristics

The suppressor is connected to the input of the appliances power line, and prevents radiofrequency disturbance from entering the power circuit.

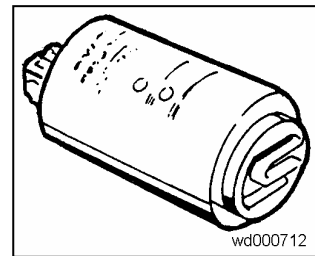

5.1.2 Electrical symbols

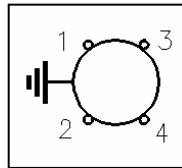
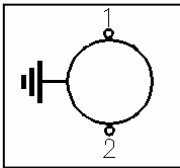

5.1.3 Circuit diagrams

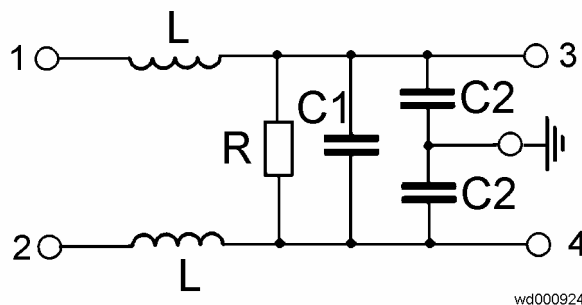
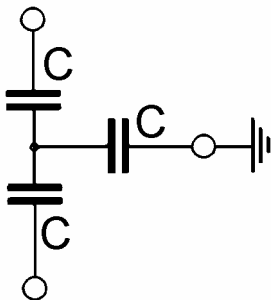

5.1.4 Checking for efficiency

THE APPLIANCE GENERATES RADIOFREQUENCY DISTURBANCE:

- check the efficiency of the earth circuit

THE APPLIANCE IS INOPERATIVE:

- Use an ohmmeter to check that the component is not faulty:
 - across 1 - 3 about 0Ω
 - across 2 - 4 about 0Ω

THE ELECTRICAL SAFETY CUT-OUTS INTERVENE:

- use an ohmmeter (capacitance meter) to check that the component is not short-circuited across 3 - 4 ($>500K\Omega$)
- check that there are no leaks to earth.

5.2 Push-button

5.2.1 General characteristics

Single-button versions are used.

These differ as regards the number and functionality of the contacts:

- switch
- deviator (single- or two-pole)

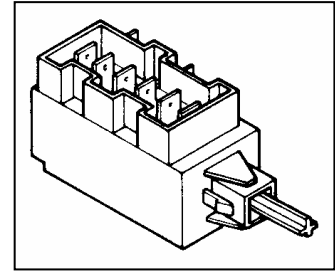

5.2.2 Electrical symbol

Normally-closed switch



Normally-open switch



Deviator



5.2.3 Checking for efficiency

DOES NOT POWER THE APPLIANCE OR DOES NOT PERFORM THE SPECIFIC FUNCTION:

- Use a tester to check for correct closure (or aperture) of the various contacts.
- Press the button and check for switching of the contacts.

IMPOSSIBLE TO ACTION THE BUTTON

- Check that the spindle is not broken and that there are no other mechanical problems (friction/breakage of couplings to cross-member).

5.3 Instantaneous door safety interlock

5.3.1 General characteristics

Certain models with electronic control systems feature an instantaneous door safety interlock. In this case, the door can be opened as soon as the drum comes to a stop.

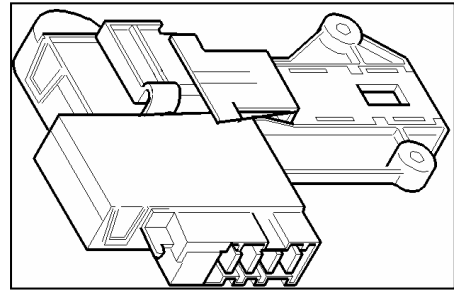

5.3.2 Operating principle

1. Solenoid protective PTC
2. Solenoid valve
3. Lever mechanism
4. Camme
5. Bi-metal PTC
6. Electrical contacts (main switch)
7. Locking latch

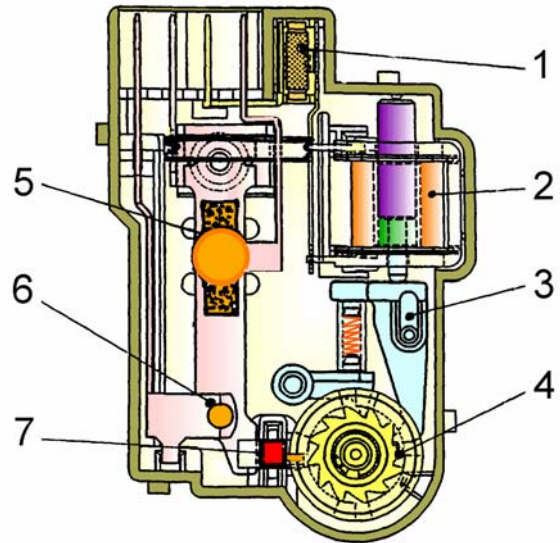

- When the appliance is switched on by pressing the ON/OFF button, the bi-metal PTC is powered; the camme is in a position that prevents the locking latch from moving outwards.
- When the programme is started by pressing START/PAUSE, the main PCB sends a signal (duration 20 msec) to the solenoid (at least 6 seconds after switching on), which causes the camme to rotate one position. The latch which locks the lever of the door safety interlock is raised and, at the same time, the contacts of the main switch are closed, thus powering all the electrical components.
- At the end of the programme, the PCB sends two signals (at an interval of 200 msec) (duration 20 msec):
 - the first signal moves the camme by another position, though the latch is not released.
 - the second signal (which is sent only if the system functions correctly) moves the camme by a further position, which causes the latch to retract, thus releasing the device; at the same time, the contacts of the main switch are opened.

5.3.2.1 "Door open" conditions

The main PCB, before sending the door aperture signals, checks for the following conditions:

- The drum must be stationary (no signal from the tachometric generator)
- The water level must not be higher than the lower edge of the door
- The temperature of the water must not be higher than 40° C.

5.3.2.2 Automatic release device

In the event of a power failure, or if the appliance is switched off using the ON/OFF switch, or if there is a fault in the solenoid valve, the bi-metal PTC cools within a period of between 55 seconds and about 4 minutes (at a temperature of 65°C), thus releasing the door.

5.3.2.3 Protective cut-out for solenoid valve

A PTC, connected in series to the solenoid valve, serves as a current limiter (i.e. overheating cut-out) in the following cases:

- If the triac on the main PCB is short-circuited
- If the START/PAUSE button is pressed repeatedly (more than 10 times)

5.3.3 Electrical symbol

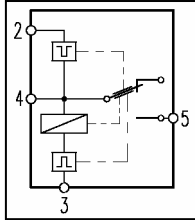

5.3.4 Circuit diagram

1. Main switch
2. Solenoid valve
3. PTC protective solenoid valve cut-out
4. Bi-metal PTC
5. Connector

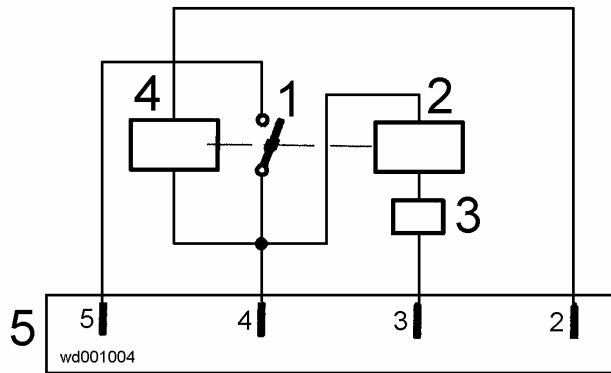

5.4 Solenoid valve

5.4.1 General characteristics

The solenoid valve ducts water through the detergent dispenser, and is controlled electrically by the pressure switch.

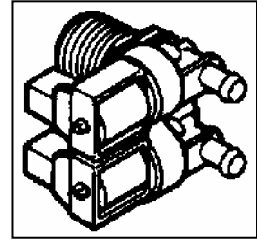

1. Water intake
2. Solenoid valve body
3. Filter
4. Flow reducer
5. Coil
6. Spring
7. Moving core
8. Rubber seal
9. Membrane
10. Water outlet

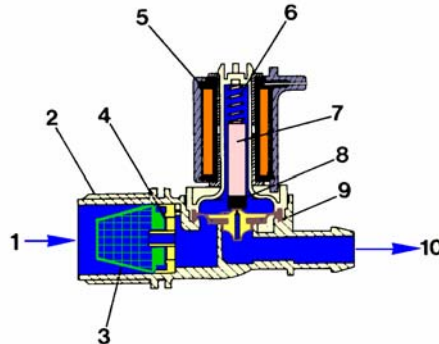

When at rest, the core, upon which pressure is exerted by a spring, holds the hole in the centre of the membrane closed; as a result, the membrane hermetically closes off access to the water intake duct. When the coil is powered, it attracts the core, which therefore opens the small hole in the centre of the membrane, and the valve opens.

Various types of solenoid valve may be fitted:

- solenoid valves with one inlet and one outlet
- solenoid valves with one inlet and two or three outlets. In this case, each section of the solenoid valve is controlled by a coil.

▪ Cold water solenoid valve

The cold water solenoid valve is fitted to all models, and has a nominal delivery of about 6.5 - 9.5 litres per minute. The water pressure must be between 3 and 100 N/cm².

5.4.2 Electrical symbol

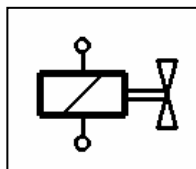

5.4.3 Checking for efficiency

WATER FILL CONTINUES WHEN THE APPLIANCE IS SWITCHED OFF:

- Solenoid valve jammed mechanically. Replace the solenoid valve

WATER FILL CONTINUES DURING THE WASHING CYCLE:

- Check the hydraulic circuit of the pressure switch and the pressure switch itself.

NO WATER FILL:

1. The solenoid valve vibrates (noise from the coil) but does not introduce water:
 - check the hydraulic circuit that supplies the solenoid valve (tap turned off, insufficient mains water pressure, fill hose kinked or obstructed).
 - Solenoid valve jammed mechanically. Replace the solenoid valve
2. The solenoid valve does not vibrate:
 - Check the coil winding (3500 - 4500 ohm); if faulty, replace the solenoid valve.
 - Solenoid valve jammed mechanically. Replace the solenoid valve
 - Check the hydraulic circuit of the pressure switch and the pressure switch itself
 - Check the timer and/or the main PCB for correct operation.

5.5 Pressure switch

5.5.1 General characteristics

The function of the pressure switch is to determine the quantity of water to be introduced into the tub. In other words:

- ⇒ It controls the water fill levels during the washing phases.
- ⇒ It acts as an anti-boiling safety device when connected in series to the heating element.
- ⇒ It can also act as an anti-overflow safety device if connected in series to the drain pump.
- ⇒ It can act as an anti-foam device during the spin phases.

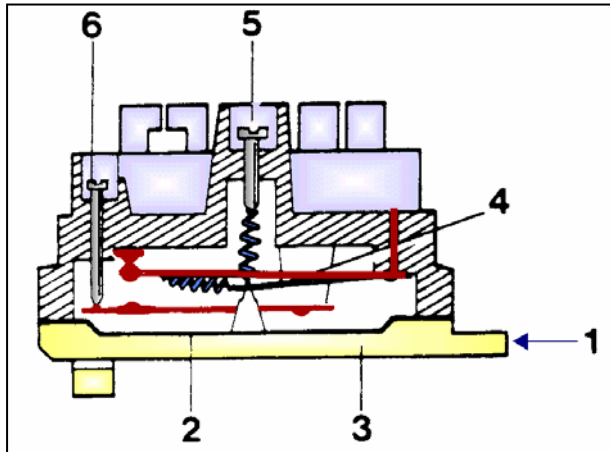
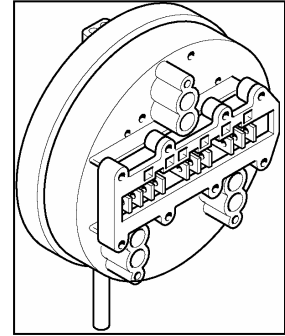

2. Air inlet aperture
3. Diaphragm
4. Internal chamber
5. Contact strip (rapid cut-in)
6. Level regulation screw
7. Differential regulation screw

The internal chamber is connected via a small tube to the pressure chamber. When water is introduced into the tub, the pressure in this chamber increases. When the pressure reaches a pre-determined level, the membrane causes the contact strip to trip (rapid-action), which switches the contact from "empty" to "full". Two regulation screws are fitted to the cover, one for the level, the other for the differential, i.e. the point at which the strip returns to the "empty" position when the level of water in the tub decreases.

5.5.2 Pressure switch hydraulic circuit

1. Pressure switches
2. Tub
3. Filter body
4. Pressure chamber on filter body
5. Pressure switch hoses

- Normally, all appliances are fitted with one or two pressure switches. Each pressure switch controls from one to three levels of water in the tub.
- The small tube from the pressure switches may be connected to the pressure chamber, which is located beneath the tub.

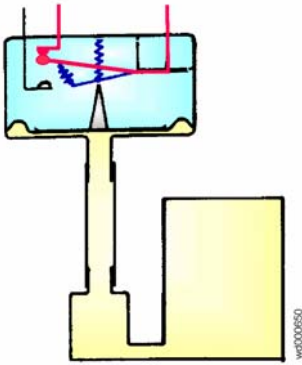
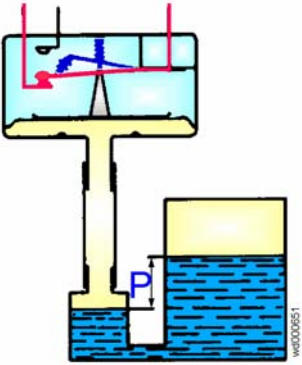
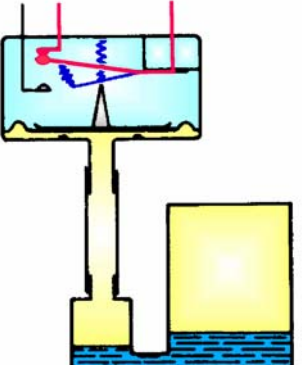

Operating principle

Tub empty	Water flows into the tub	Water is drained from the tub
<p>As there is no water in the tub, there is no pressure on the diaphragm, which thus remains in the lower position due to the counterforce exerted by the spring.</p> <p>In this position, the contact is closed on "empty".</p>	<p>When the connection between the tub and the pressure chamber is interrupted by the water, the pressure between the pressure chamber and the internal chamber of the pressure switch increases.</p> <p>This increase continues until the diaphragm is raised sufficiently to action the switch (rapid-action). In this position, the contact is closed on "full".</p>	<p>As the level of water in the tub diminishes, the pressure exerted on the diaphragm is reduced.</p> <p>The diaphragm is pushed downwards by the counterspring until the switch resets (i.e. returns to the "empty" position).</p>
		

5.5.3 Electrical symbol

1. Common contact
2. Contact closed on "empty"
4. Contact closed on "full"

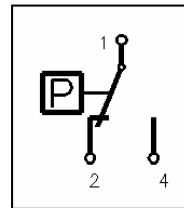

5.5.4 Circuit diagram

11-21-31: "Common" contact

12-22-32: "Empty" contact

14-24-34: "Full" contact

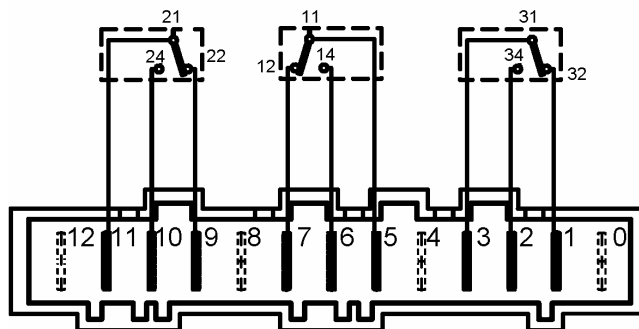

5.5.5 Checking for efficiency

Correct operation of the pressure switch depends on the correct operation of its hydraulic circuit (tube and pressure chamber):

- Check for leaks (in which case too much water would be introduced, as the switch would not close on "full" or, in the event of microleakage, would return to "empty").
- Check for obstruction (in which case the contacts may be jammed on "full" or "empty").

After checking the hydraulic circuit:

- Introduce water into the tub to the highest level and check that the contacts close correctly on "full".
- Drain the water from the tub and check that the contacts close correctly on "empty".

5.6 Analogue (electronic) pressure switch

5.6.1 General characteristics

The electronic pressure switch is an analogue device whose function is to control the level of water in the tub; it is used in certain models with electronic control systems (EWM2000EVO – EWM3000NEW). The electronic circuit is connected directly to the main PCB.

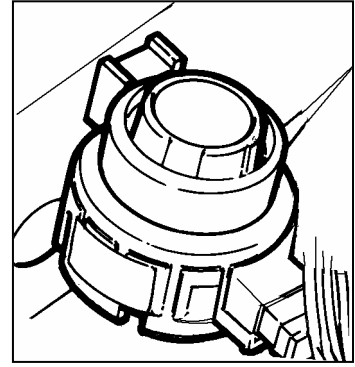

5.6.2 Operating principle

1. Air intake tube
2. Membrane
3. Coil
4. Electronic circuit (oscillator)
5. Core
6. Spring
7. Calibration spring
8. Connector

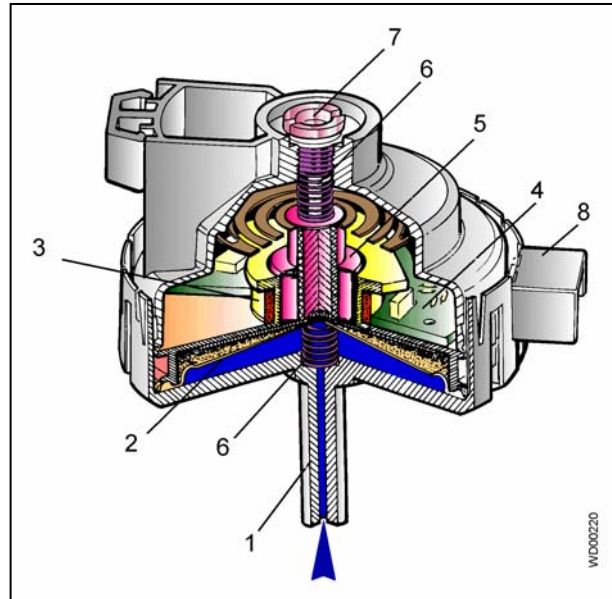

The pressure switch is connected via tube to the pressure chamber. When water is introduced into the tub, this creates a pressure inside the hydraulic circuit that causes the membrane to change position. This movement of the membrane modifies the position of the core inside the coil, varying its inductance and thus the frequency of the oscillating circuit. The PCB recognizes how much water has been introduced into the tub according to the frequency.

5.6.3 Electrical symbol

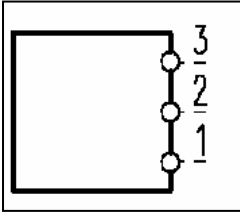

5.6.4 Circuit diagrams and operating frequency

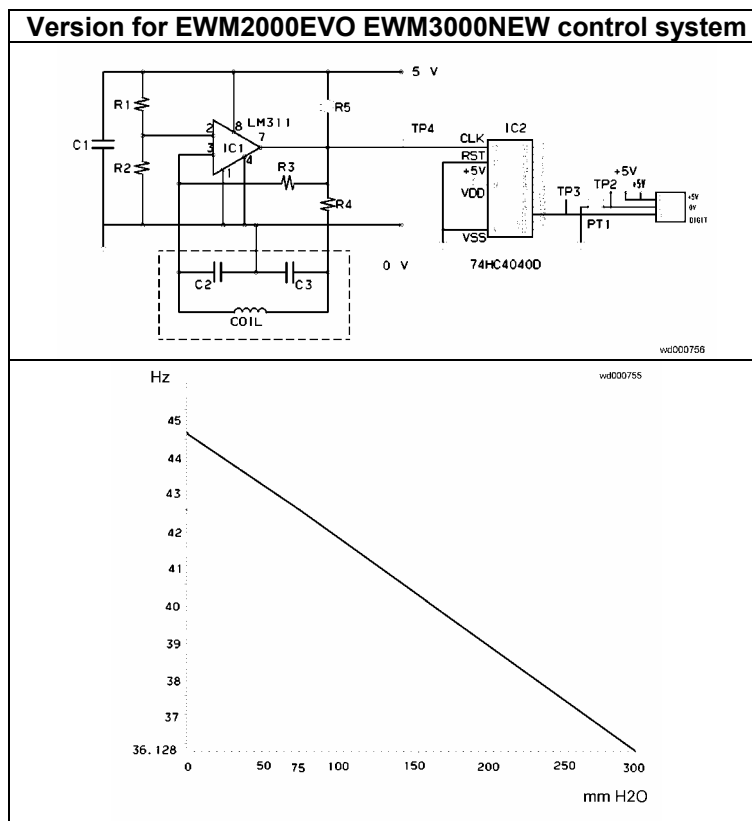

5.6.5 Checking for efficiency

In the event of a fault in the pressure switch, the operation of the appliance is immediately interrupted. Where possible, always read the alarm code.

Possible alarm codes caused by faults in the pressure switch:

- **EWM2000-EWM3000NEW:** E31, E32, E33, E34, E35

5.7 Induction (asynchronous) motors

5.7.1 General characteristics

The function of the motor is to rotate the drum at different speeds:

- ⇒ high speed for the spin phases
- ⇒ low speed for the wash phases

The primary characteristics of these motors is that they do not require a start-up current. Instead, the current in the rotor builds up by induction, hence the name "**induction**" motor. These motors are also termed "**asynchronous**" because the speed of rotation is not the same as the synchronization speed.



5.7.2 Operating principle

The three-phase asynchronous motors consist of a stator on which the solenoids are wound (windings impregnated with resins which guarantee an optimal water protection) which are the polar expansions. These are always a three-multiple number.

Inside the stator, there is an integral rotor to the shaft made up of a group of magnetic blades including also (normally die-cast aluminium) a circuit called *squirrel cage*, because it consists of a series of bars forming a cylinder between two rings.

When the stator generates a rotating magnetic field, electrical currents are induced into the cage. These, opposing to the generator field, produce a twisting movement to the rotor.

The maximum rotation per minute of an asynchronous motor depends on the power frequency and on the number of polar couples.

The three-phase motors are highly efficient due to the absence of brushes. They can be powered also with inverter circuits, starting from a direct current power source.

The stator windings can be connected by *star* or by *triangle*.

5.7.3 Checking the efficiency

It is possible to have an indication of the efficiency of the motor by measuring the windings resistances:

Winding y ohm 5,6 ~ ±7% (contacts 2-3)

Winding x ohm 5,6 ~ ±7% (contacts 2-1)

Winding z ohm 5,6 ~ ±7% (contacts 3-1)

Winding T (tachometric) ohm 120 ~ ±7% (contacts 4-5)

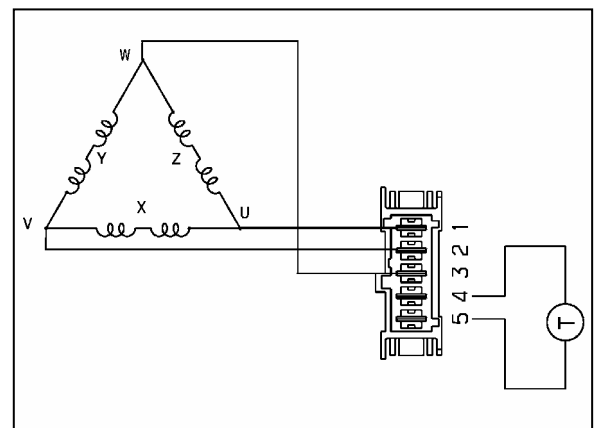

5.8 Commutator motor

5.8.1 General characteristics

Commutator motors are fitted to appliances with spin speeds of between 600 and 1,600 rpm.

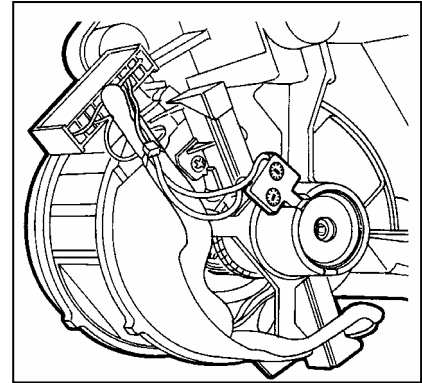

1. Stator
2. Terminal block
3. Commutator
4. Tachometric generator magnet
5. Tachometric generator coil
6. Brush

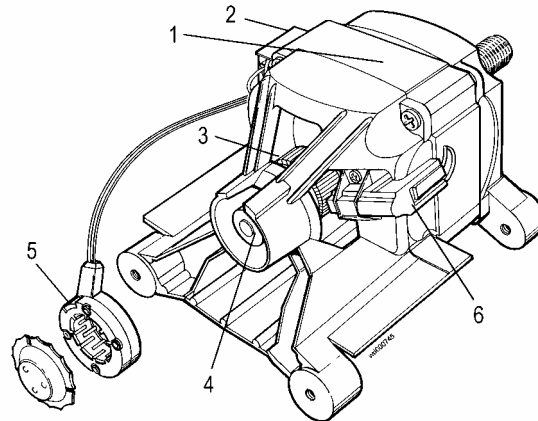

1. Stator
2. Stator winding
3. Brush
4. Commutator
5. Rotor winding
6. Motor drive shaft
7. Pulley
8. Bearing
9. Tachometric generator coil
10. Magnet
11. Spring

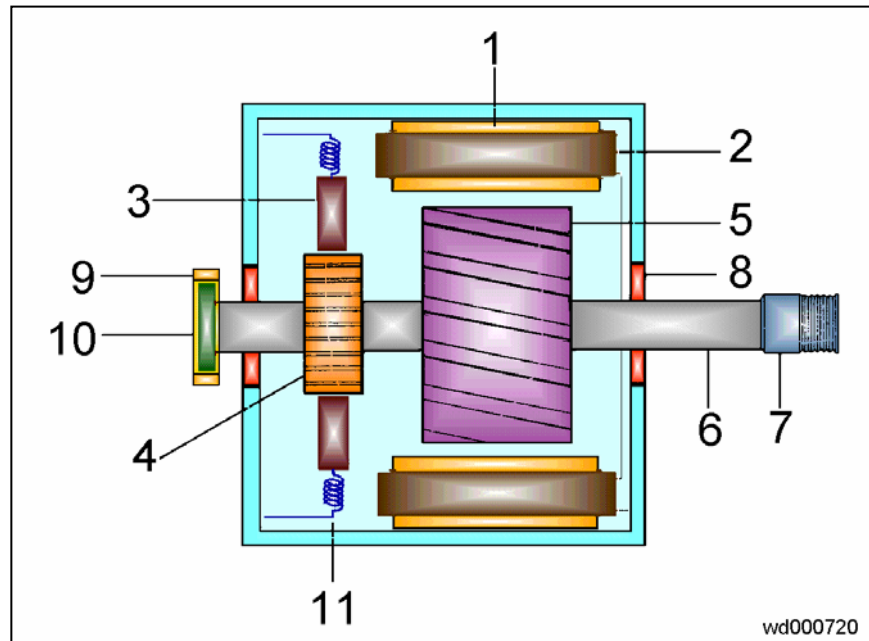

wd000720

5.8.2 Operating principle

The stator winding is connected in series to the rotor winding (i.e. they are energized in series). Each section of the rotor winding is connected to a pair of commutator plates (also called "commutators"). The electrical contact between the commutator and the fixed circuit is provided by two brushes which slide in contact with the commutator plates.

The speed of rotation of the motor is proportional to the power voltage supplied by an electronic control system.

This is also known as a "universal" motor, since it can be powered either by alternating or direct current.

5.8.2.1 Control of the speed of the motor

- Speed control is obtained by using an electronic control system to vary the voltage (V) applied to the motor.
- The technique used consists of a "phase division" performed by the Triac. A Triac is a bi-directional electronic switch. Closure of the circuit between A1 and A2 (anodes) takes place in the presence of the appropriate signals received by the gate (G).

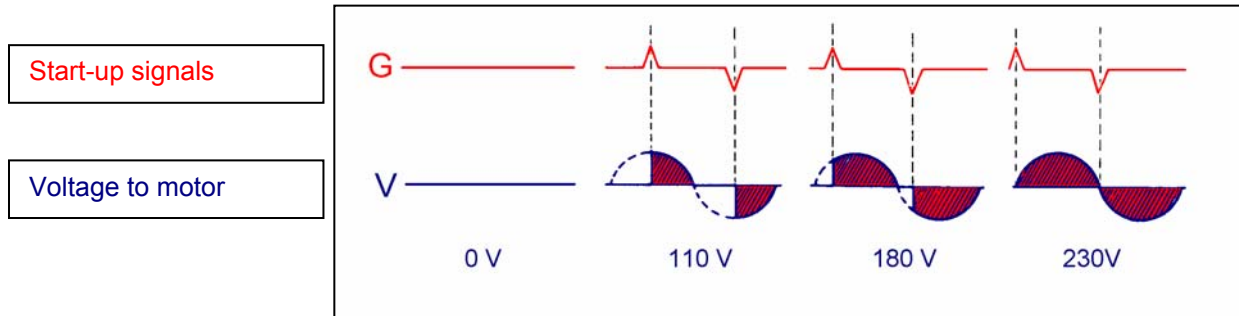
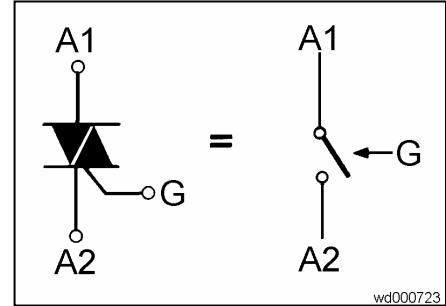
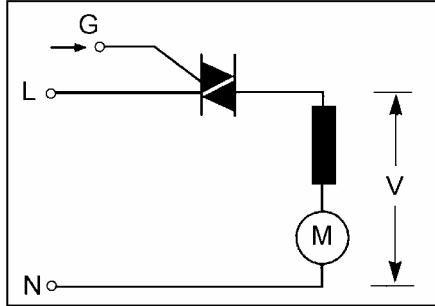

5.8.2.2 Direction of motor rotation

The direction of rotation of the motor depends on the way in which the rotor and stator are connected together. This connection is performed by two of the timer contacts or by the relays on the PCB.

Clockwise rotation

Counter-clockwise rotation

- EC Electronic control system
- P Motor overload cut-out
- S Stator
- R Rotor
- T Tachometric generator
- TY Triac
- R1,2 Reversal relay

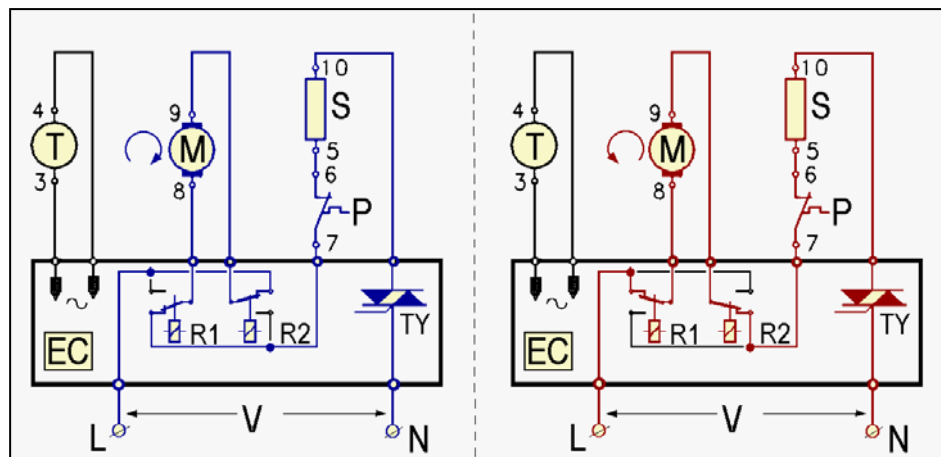

5.8.2.3 Tachometric generator

As in all motors powered in series, the speed of the commutator motor depends on the load. In other words, its speed diminishes as the load increases. This makes it necessary to ensure that the power voltage to the motor, and therefore its speed, be constantly controlled by an electronic speed control system.

A tachometric generator (consisting of a magnet fitted to the shaft and a coil) generates a voltage that depends on the speed of the rotor, which is transmitted to the electronic control system.

All electronic control systems feature a system of protection (which may be more or less refined) to prevent operation of the motor in the event of a fault in the tachometric generator.

- M Electronic control system
- P Motor overload cut-out
- S Stator
- R Rotor
- T Tachometric generator
- TY Triac
- R1,2 Reversal relay

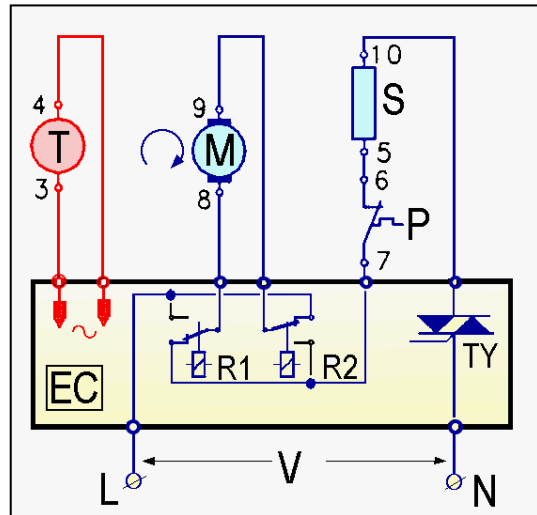

5.8.3 Electrical symbols

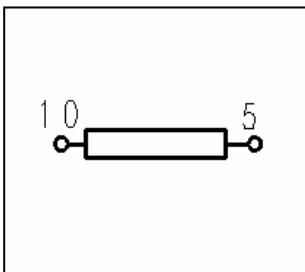

Stator

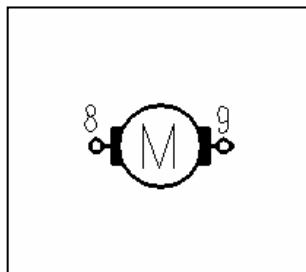

Rotor

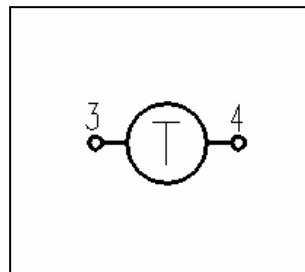

Tachometric generator

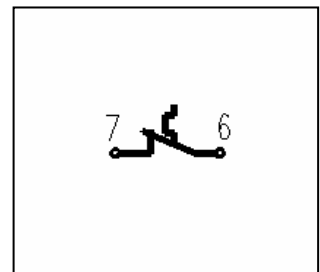

Overheating cut-out

5.8.4 Circuit diagram

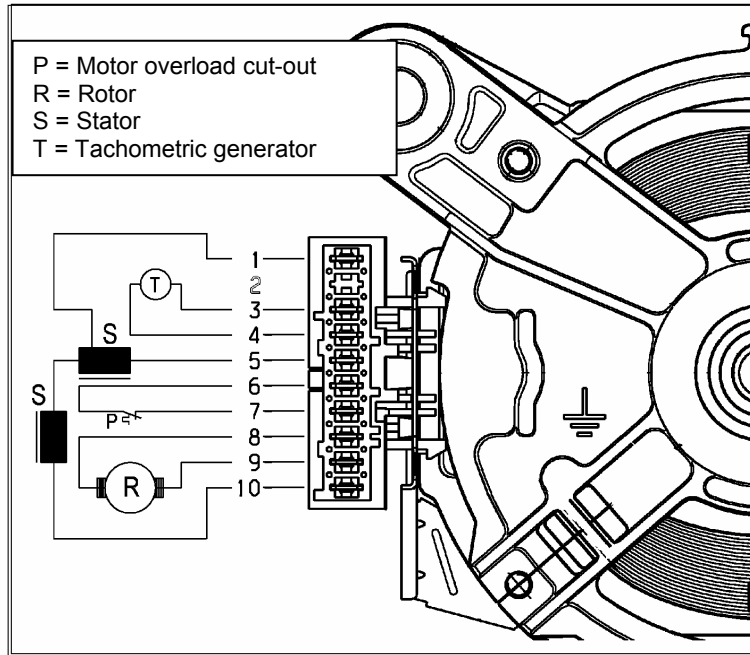

5.8.5 Checking for efficiency

1. Check the connector blocks (wiring) and check for any bent or detached terminals.
2. Check for traces / residue / deposits of water or detergent and identify their source.
3. Check for any windings / components connected to mass or inadequately earthed using a tester with a minimum scale of 40mW across each terminal and the casing (correct reading is ∞).
4. Check the individual windings against the values shown in the table below:

Terminals on motor connector block	Components to be checked	Motor [Ω]
3 - 4	Tachometric generator winding	184
5 - 10	Stator winding (full range)	1,23
6 - 7	Overload cut-out	0
8 - 9	Rotor winding (④)	1,72

(④) excluding the resistance of the brushes

Notes:

- When checking the rotor winding, measurement should be effected around the entire surface, turning the spindle very slowly and checking for any short-circuits between visible plates. Also check the carbon brushes for wear.
- If noise is generated (bearings-magnet-belt), detach the drive belt from the pulleys and locate the source.

5.9 Heating element

5.9.1 General characteristics

The heating element that heats the washing water is encapsulated, i.e. inserted into a watertight stainless steel tubular casing.

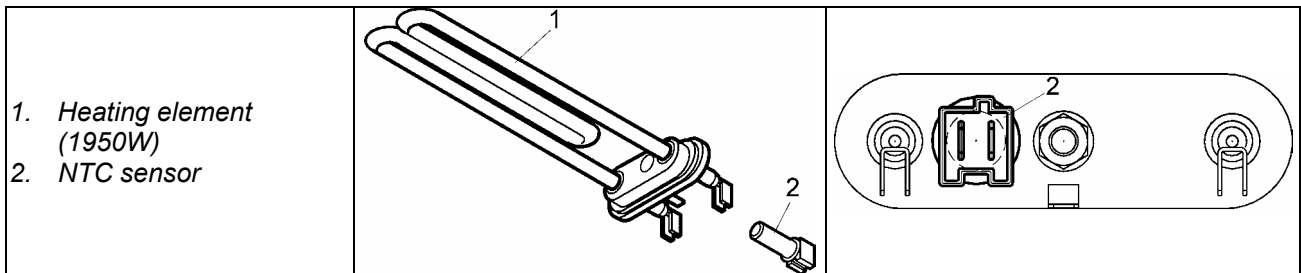

5.9.1.1 Seal

The seal between the tub and the heating element is provided by a seal which expands against the nut.

1. Fixed flange
2. Washer
3. Moving flange
4. Nut
5. Heating element terminals
6. NTC Sensor

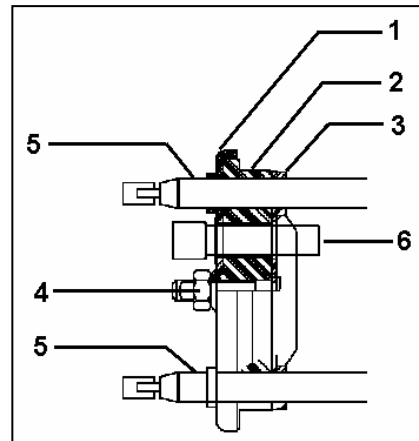

5.9.2 Electrical symbol

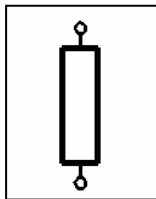

5.9.3 Checking for efficiency

DOES NOT HEAT:

- check that the heating element is not broken: measure the resistance across the two terminals.

INTERVENTION OF ELECTRICAL SAFETY CUT-OUTS:

- use an ohmmeter to check that the heating element is not connected to mass and check for current leakage (40 M Ω)

WATER LEAKS:

- check that the seal is correctly positioned and fitted.

VIBRATION OR METALLIC NOISE WHEN THE DRUM ROTATES:

- check that the heating element is correctly positioned inside the tub. If worn, replace the heating element.

5.10 NTC temperature sensor integrated in the heating element

5.10.1 General characteristics

In the electronic models an NTC sensor is used to control the washing temperature. In these sensors, the internal resistance decreases as the temperature increases. This reduction in resistance is detected by the electronic control system which, when the desired temperature is reached, disconnects the heating element.

1. NTC resistor
2. Metal capsule
3. Terminals
4. Plastic casing

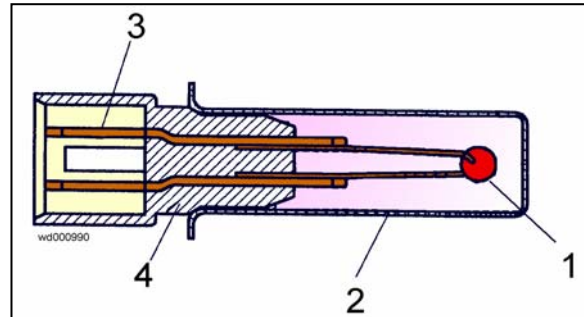

TEMPERATURE (°C)	RESISTANCE (Ω)		
	Rated value	Maximum value	Minimum value
20	6050	6335	5765
60	1250	1278	1222
80	640	620	660

5.10.2 Electrical symbol

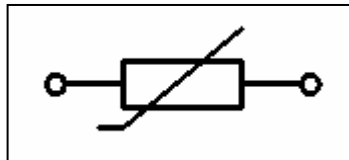

Checking for efficiency

Use a tester to check that the resistance of the sensor corresponds to the temperature.

5.11 Drain pump

5.11.1 General characteristics

The function of the drain pump is to discharge the water at the end of each phase of the washing cycle. These centrifugal pumps are actioned by a synchronous motor.

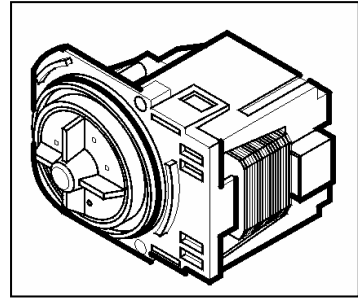

1. Impeller
2. Rotor
3. Stator

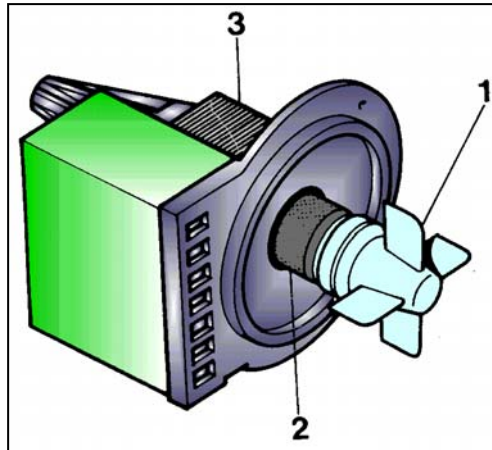

The rotor consists of a permanent magnet, and may rotate in either direction.

The rotor may rotate for approximately 15 minutes without actioning the impeller. As a result, if the impeller is jammed by a foreign body, the rotor may perform short clockwise and anti-clockwise movements until the blockage is removed.

These pumps have a delivery of about 22-25 litres per minute, and a maximum head of 90 cm.

5.11.2 Electrical symbol

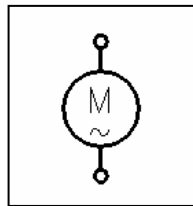

5.11.3 Checking for efficiency

1. Check that the impeller is not jammed and check for slippage.
2. Check the resistance of the stator winding, which should be approximately 150/200 Ω .

Important!

If caused to run empty (i.e. disconnected from the hydraulic circuit), synchronous pumps may fail to start up. This is because, due to their structural characteristics, they require a counter-torque on the impeller to allow the rotor to turn in one direction or the other.

For this reason, the pumps should be tested only when fitted to the appliance and after introducing a certain quantity of water.

5.12 Circulation pump

5.12.1 General characteristics

Jetsystem models are fitted with a synchronous circulation pump which continuously circulates the water from the filter body into the tub through the bellows seal.

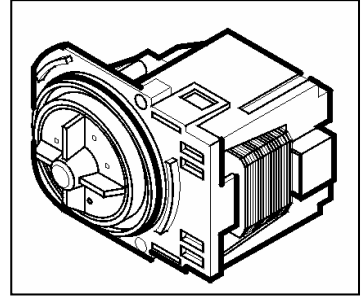

5.12.2 Electrical symbol

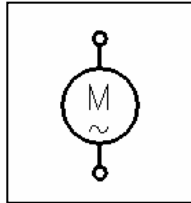

5.12.3 Checking for efficiency

NO RE-CIRCULATION - POOR WASHING RESULTS

1. Check that the impeller is not jammed and check for slippage.
2. Check the resistance of the stator winding, which should be approximately 150/200 Ω .

WATER IN THE BASE AND ON THE FLOOR
Check the seals on the duct/thermostat holes

Important!

If caused to run empty (i.e. disconnected from the hydraulic circuit), synchronous pumps may fail to start up. This is because, due to their structural characteristics, they require a counter-torque on the impeller to allow the rotor to turn in one direction or the other.

For this reason, the pumps should be tested only when fitted to the appliance and after introducing a certain quantity of water.

6 ACCESS TO COMPONENTS

6.1 Work-top

- a. Remove the two rear screws (1), push the work-top towards the rear of the appliance and detach.

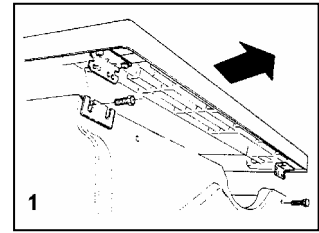

6.1.1 Pressure switch

- a. Remove the work-top.
- b. Detach the wiring connectors.
- c. Press the anchor tabs (2) and pull towards the rear.
- d. Detach the pressure switch tube.

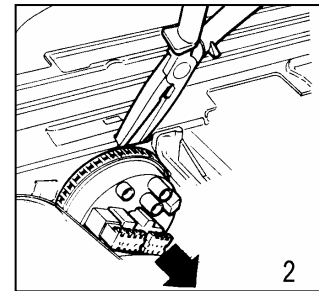

6.1.2 Suppressor

- a. Remove the work-top.
- b. Detach the wiring support from the crosspiece and move downwards (3).
- c. Remove the suppressor.
- d. Detach the wiring connectors.

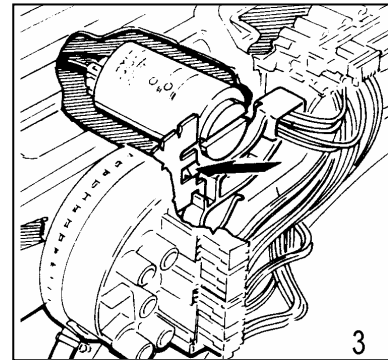

6.1.3 Solenoid valve

- a. Remove the work-top.
- b. Unscrew the water fill hose from the solenoid valve.
- c. Detach the wiring connector.
- d. Detach the solenoid valve from the support (4).
- e. Remove the hose clamp and detach the solenoid valve from the hose.

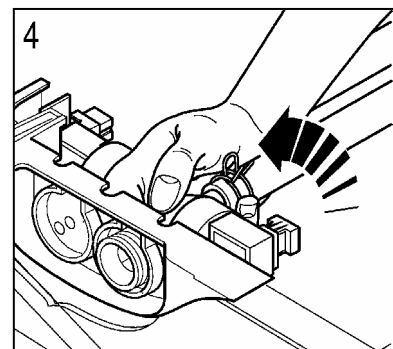

6.2 Control panel

- Remove the work-top.
- Extract the detergent drawer. (Fig.5)
- Remove the screws that secure the control panel to the control panel support. (Fig.6)
- Remove the lateral (b) screws which secure the control panel to the crosspiece and release the anchor tabs (a) from the support. (Fig.7)
- Release the control panel from the lower right-hand guide and remove. To facilitate its release, unscrew the screw which secures it to the cabinet and lift the control panel support slightly. (Fig.8).

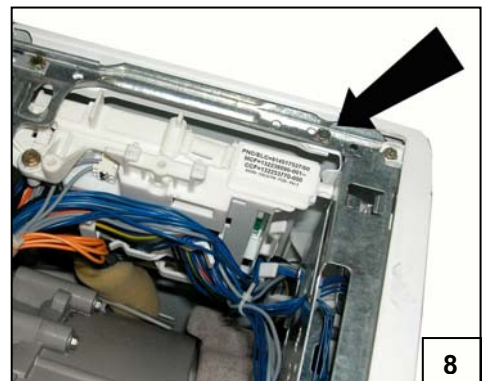
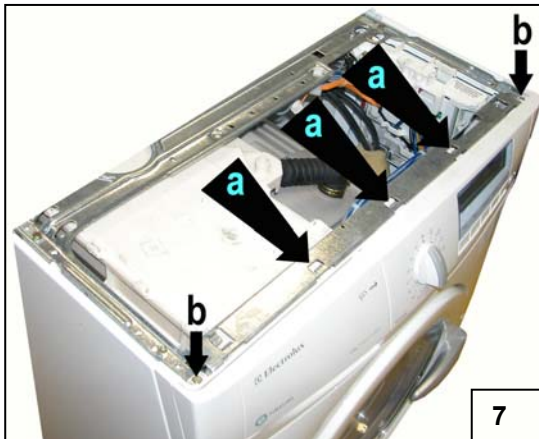
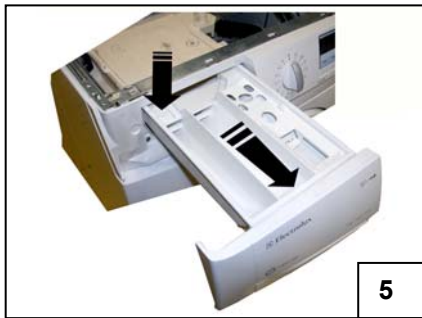

6.2.1 Push-button

- Remove the control panel.
- Using a screwdriver, widen the pushbutton anchor pin and remove the pushbutton.
- Remove the pushbutton. Using pliers, close the anchor tabs which secure the button to the cross-member and push towards the interior of the appliance.
- Detach the connector.

6.3 Electronic control

6.3.1 Main electronic control (EWM2000EVO-EWM3000NEW)

- Remove the top.
- Remove the screw (c) which secures the support to the board casing (Fig.9).
- Detach the wiring from the supports.
- Move the board towards the interior of the appliances.
- Extract the casing-PCB assembly.
- Detach the connectors.

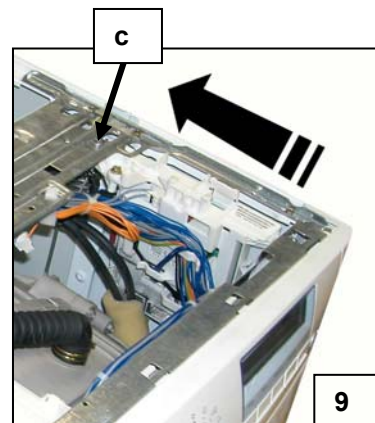

6.3.2 Control/display board

The way in which these boards are fastened depends on the styling version. To access the board:

- a. Remove the control panel
- b. Release the PCB casing from the control panel or remove the screws.

For further details, refer to the specific Service Manuals for the various types of electronic control systems.

6.3.3 Electronic pressure switch

- a. Remove the top.
- b. Press down the anchor tabs and release the pressure switch from the support. (Fig. 10)
- c. Detach the connector.
- d. Detach the tube.

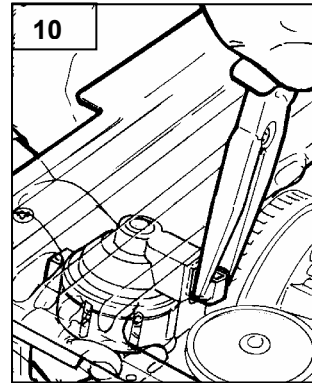

6.4 Access from the door

6.4.1 Door

- a. Remove the two screws which secure the door to the hinge. (Fig. 11)
- b. Remove the screws which secure the surround-flange (if present) and detach the flange from the surround.
- c. Remove the glass door panel.
- d. Remove the handle-latch assembly.

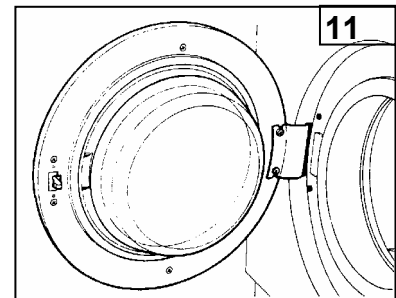

Re-assembly:

- e. Position the handle assembly in its housing in the flange so that the spring exerts pressure correctly.
- f. Refit the glass panel to the flange.
- g. Replace the surround and the screws.

6.4.2 Door hinge

- a. Remove the porthole door.
- b. Detach the seal front the front panel. (Fig. 12)
- c. Remove the screws which secure the hinge to the front panel.
- d. Remove the hinge.

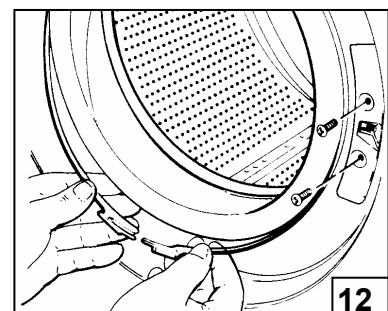

6.4.3 Door safety interlock

- a. Remove the seal from the front panel. (Fig. 12)
- b. Remove the two screws which secure the door delay device to the front panel.
- c. Remove the door delay device. (Fig. 13)
- d. Remove the cover from the door delay device.

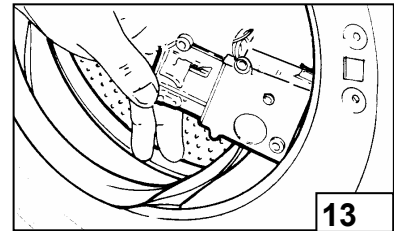

6.4.4 Bellow seal

- a. Detach the retaining ring and the seal from the front panel.
- b. Remove the clamp and pull out the circulation tube. (Fig. 14)
- c. Remove the seal and the ring by pulling downwards (it is held in position by an elastic ring).

Re-assembly:

- a. Use soap and water to lubricate the seat of the seal where it comes into contact with the flange and the metal ring.
- b. Fit the seal to the flange with the drainage hole at the bottom and the internal reference notch at the top (Fig. 15).
- c. Replace the metal retaining ring (check that the ring is in good condition, otherwise it should be replaced).
- d. Replace the circulation hose and the hose clamp (Fig. 16).
- e. Fit the seal to the front panel and replace the clamp.

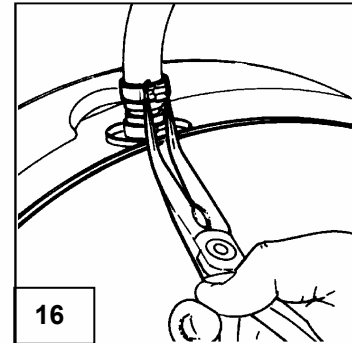
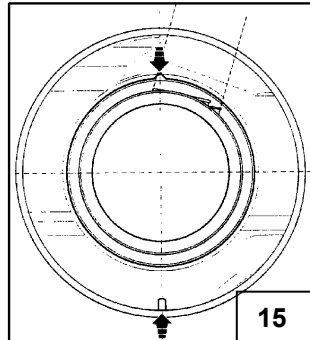
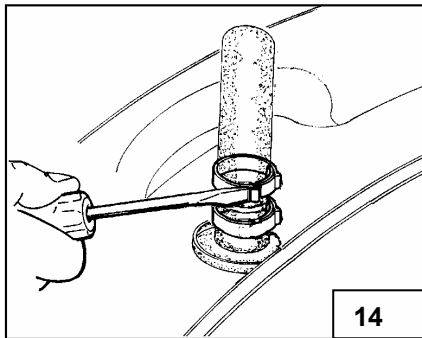

6.5 Rear cabinet shell

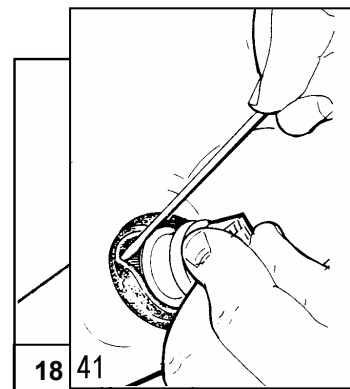
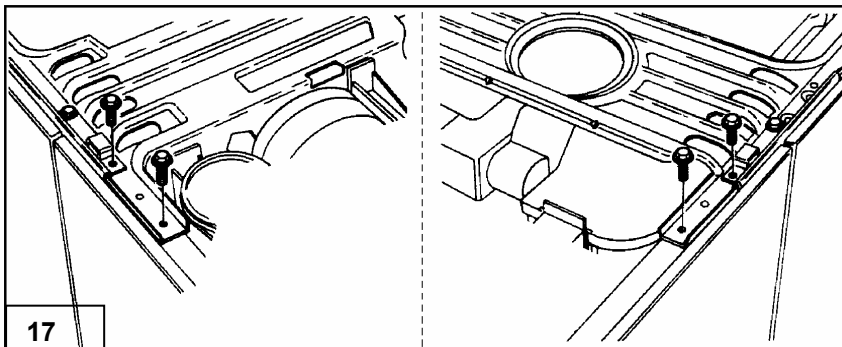

- Remove the top.
- Remove the screws which secure the cabinet shell to the upper crosspiece. (Fig.17)
- Remove the screw head masking caps and remove the lateral screws which secure the cabinet shell to the base. (Fig.18)
- Detach the wire clamp from the cabinet. (Fig.19)
- Remove the rear screws and slide the cabinet shell away from the base. (Fig.20)

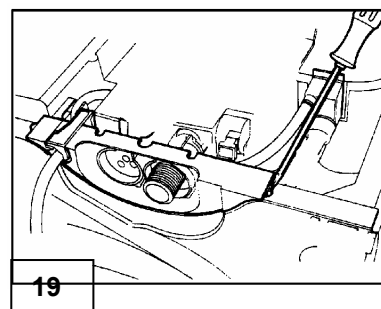

N.B.: After removing the rear cabinet shell, special care must be taken when moving the appliance. When the shell is removed, never lay the appliance on its sides or on its back, since this might damage the internal structure.

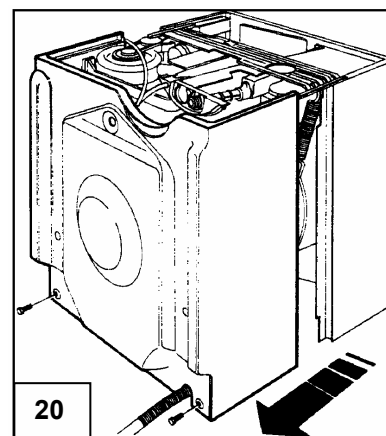

6.5.1 Motor

- Remove the rear cabinet shell.
- Detach the wiring connectors.
- Remove the rear screws which secure the motor and loosen the front screws. (Fig.21)
- Loosen the motor from the supports. (Fig.22)
- Remove the front screws and remove the motor.

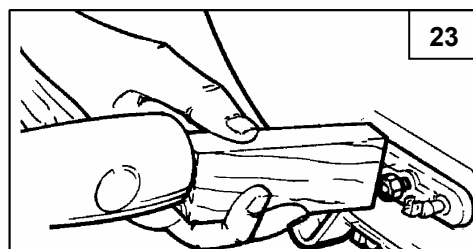
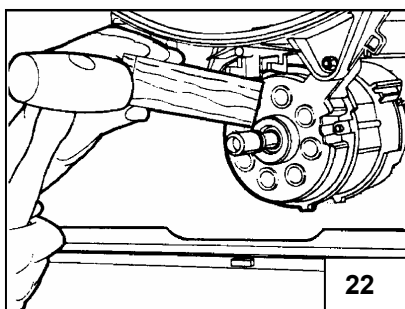
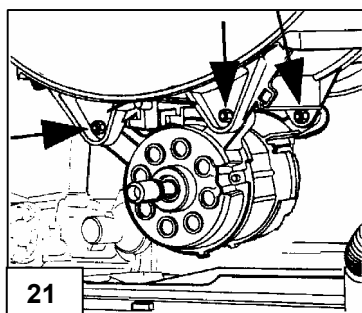

6.5.2 Heating element

- Remove the rear cabinet shell.
- Detach the drive belt from the pulleys.
- Detach the wiring connectors.
- Remove the screw which secures the heating element flange.
- Push the nut on the heating element flange towards the interior of the tub (Fig. 23).
- Remove the heating element (Fig.24)

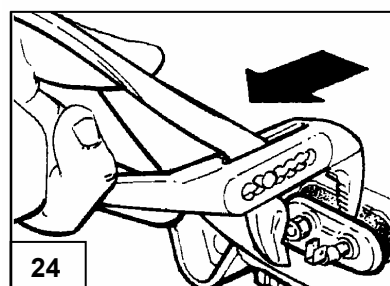

6.5.3 Detergent dispenser

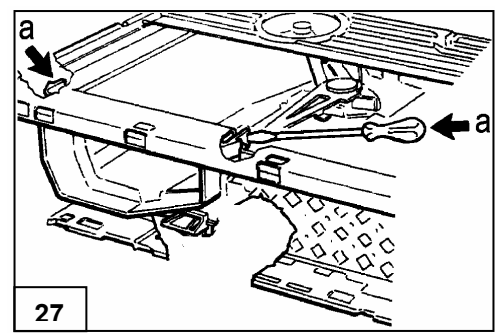
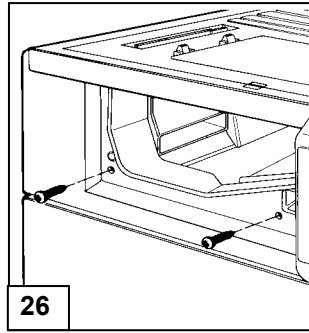
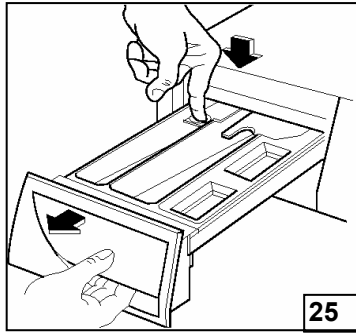

- Remove the rear cabinet shell.
- Unscrew the clamp and detach the tube from the detergent dispenser to the tub.
- Detach the steam venting tube from the tub (if present).
- Extract the detergent drawer. (Fig.25).
- Remove the screw which secures the control panel to the detergent dispenser. (Fig.26)
- Remove the screws which secure the detergent dispenser to the crosspiece.
- Detach the tube(s) from the dispenser to the solenoid valve.
- Release the two lateral anchor tabs (a) from the front crosspiece (Fig. 27) and, at the same time, push the detergent dispenser towards the rear.
- Lower the washing group and pull the dispenser out.

6.5.4 Removing the duct from the dispenser

- Remove the dispenser.
- Release the clamp and the anchor tabs for the duct from the lower part of the dispenser (Fig.28).

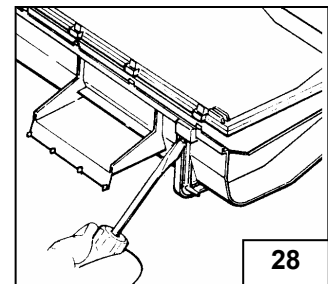

From inside the dispenser, the engineer can access:

- The water intake nozzle, which is removed by lifting from the dispenser.
- The steam venting hose.

6.5.5 Damper

- Remove the rear tub shell.
- Press the locking key and at the same time remove the pin using pliers. (29)
- Remove the damper from the support.

When re-assembling:

- ⇒ Check that the pin is not damaged; if so, replace it.
- ⇒ Check that the anchor tabs protrude correctly.

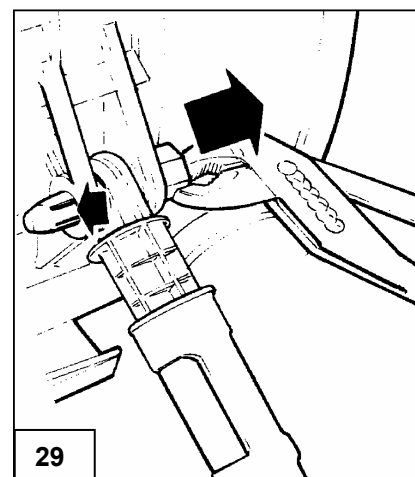

6.5.6 Drum pulley

- a. Remove the rear tub shell.
- b. Detach the drive belt from the pulley.
- c. Block the pulley in position and remove the screw.
- d. Remove the pulley.

6.5.7 Pressure chamber

- a. Remove the rear cabinet shell.
- b. Loosen the clamps and detach the pressure switch tubes from the pressure chamber.
- c. Remove the screw. (Fig. 30)
- d. Use pliers to widen the spring clip and detach the pressure chamber from the tub hose.

When re-assembling: Check that the pressure chamber is clean and secure the tubes and clips firmly in their original positions.

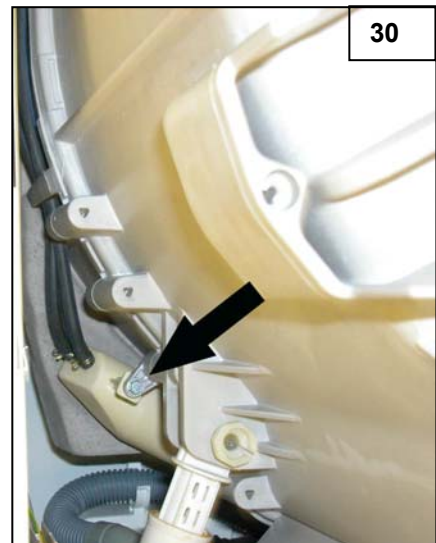

6.6 Washing group

- a. Remove the fixing ring and detach the bellows seal from the front panel.
- b. Remove the rear shell.
- c. Remove the clamps from the tub suspension springs. (Fig.31)
- d. Detach the various hoses from the tub (dispenser-tub, steam venting hose, tub-manifold etc.).
- e. Remove all the wiring connectors from the components fastened to the tub (motor, heating element, thermostats) and, if present, the bulb of the adjustable thermostat.
- f. Remove the motor to lighten the tub.
- g. Remove the fixing screws and remove the rear counterweight.
- h. Lay the appliance face down (on a sheet of polystyrene or cardboard to prevent scratching the cabinet).
- i. Use a piece of string or wire to detach the tub suspension springs from the crosspiece. (Fig.32)
- j. Remove the tub from the appliance.

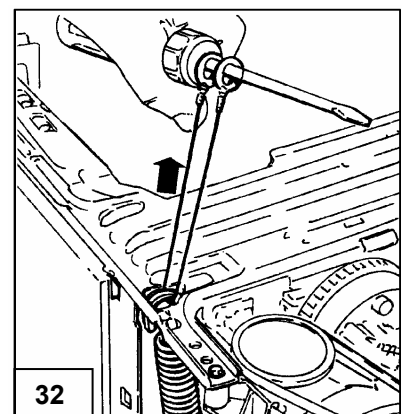
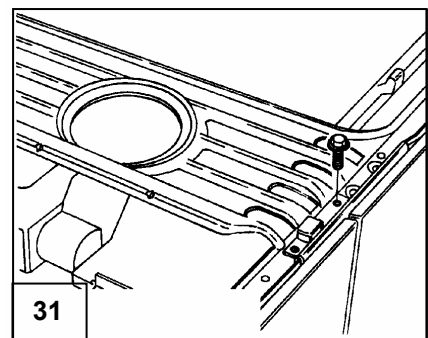

6.7 Drum and tub shells

- a. Remove the drum pulley and the motor.
- b. Remove the tub from the appliance.
- c. Remove the screws which secure the two shells together.
- d. Remove the drum.

Re-assembly: It is advisable to replace the sealing ring between the two tub shells whenever the tub is opened. Connect the hoses to the tub in the correct positions.

6.7.1 Drum shaft bearings

If it is necessary to replace the bearings, the engineer may:

- replace the rear tub shell complete with bearings and sealing ring.
- replace the bearings and the sealing ring only.

In the latter case:

- a. Remove the tub and the drum from the appliance.
- b. First remove the external bearing, then the internal bearing with its seal.

When re-assembling:

- *In order to prevent damage to the bearing and the seal during re-assembly, use spacers of the appropriate diameter*
- *Pack the bearings with the specific grease all around the sealing ring (Fig. 33).*
- *Check that the drum shaft bushing is undamaged, otherwise replace the drum spider or the drum itself.*

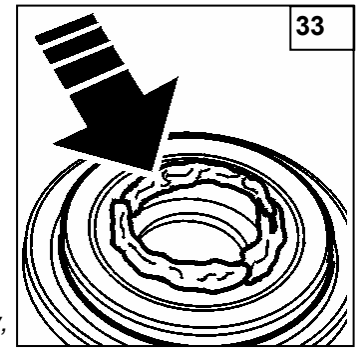

6.7.2 Drum spider

- a. Remove the screws which secure the spider to the drum.
- b. Use two narrow chisels to remove the spider from the drum band.

When re-assembling:

- a. *Replace the spider on the drum ensuring that the fixing holes are correctly aligned.*
- b. *Insert the spider into the seat in the drum band and, if necessary, rotate it until the holes are correctly aligned.*
- c. *If the same screws are used, clean and apply thread fixing paste.*
- d. *Tighten the screws securely.*

6.7.3 Front counterweight

⇒ **version with front-mounted fixing screws**

- a. Remove the tub.
- b. Replace both the shell and the front counterweight to prevent the possibility of breakage due to vibration.

6.8 Drum lifter

The drum lifter can be removed from the interior for tubs in Carboran of type G23.

▪ Removal

- a. Insert a screwdriver into the following holes:
 - ⇒ for G13 tubs, into the fourth hole in the lifter
 - ⇒ for G10-G11-G12-G18-G19 tubs, into the third hole in the lifter
 - ⇒ for G17 tubs, into the second hole of the lifter
- b. Bend the drum anchor tabs as shown in the figure (34)
- c. Pull the drum lifter towards the door of the appliance and detach from the drum (Fig.35)

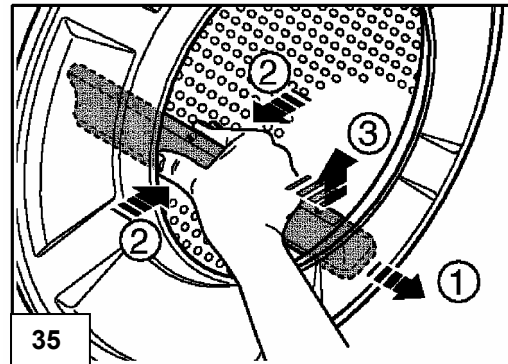
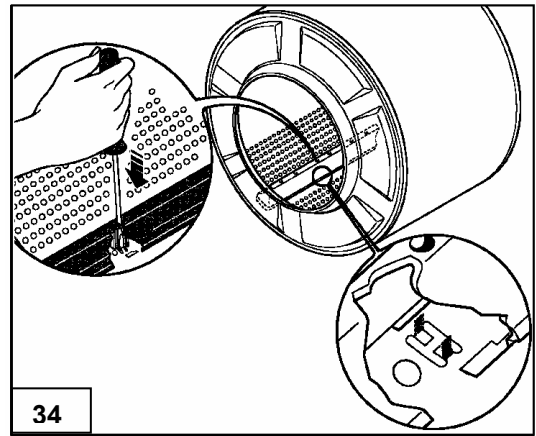

▪ Re-assembly

- a. Check that the anchor tabs are parallel with the drum band.
- b. Insert the new lifter into the drum and push towards the rear of the appliance.
- c. Detach the hose connecting the tub to the filter body
- d. Tighten the screw through the hole in the tub to secure the lifter to the drum (Fig.36)

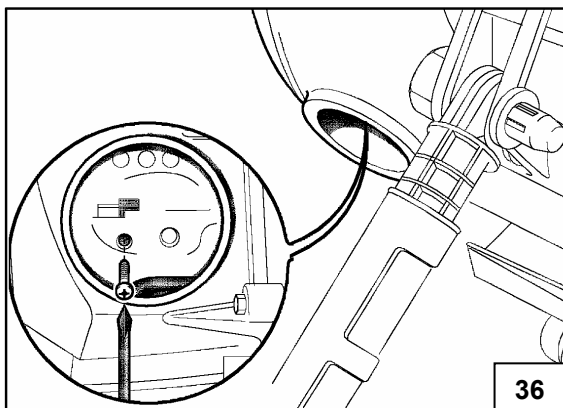

6.9 Access to the pumps/manifolds

Important!

Do not fit the circulation pump in place of the drain pump and vice versa!

6.9.1 Drain pump (standard version)

To access the drain pump, it is not necessary to remove the rear cabinet shell. The pump can be accessed from the base.

- Detach the clamps which secure the filter body to the base and raise slightly. (Fig. 37)
- Remove the drain pump.
- Detach the drain hose.
- Detach the wiring connectors.

When re-assembling, ensure that the OR seal is fitted to the pump. To facilitate insertion, lubricate with vaseline or silicone oil. Check that the pump is correctly housed in its seat in the filter body.

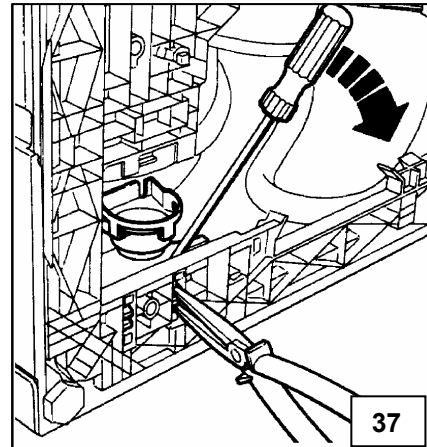

6.9.2 Drain pump

Access to the pump is from the base of the appliance:

- Remove the cover.
- Detach the connectors.
- Press down the anchor tab. (Fig. 38c)
- Turn the pump counter-clockwise. (Fig. 38d)
- Remove the pump. (Fig. 38e)

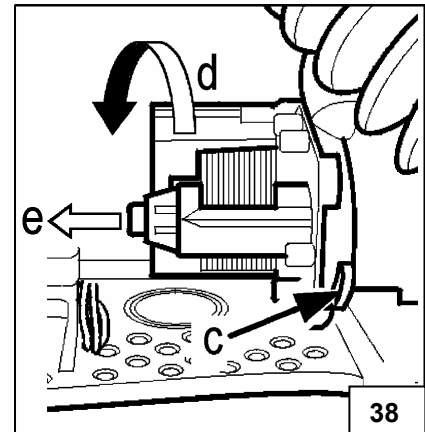

When re-assembling:

- Insert the pump fully into its seat in the filter body before rotating it.
- Check that the anchor tab is undamaged. If so, use a 3.5x19 mm screw to secure the pump (Fig.39).

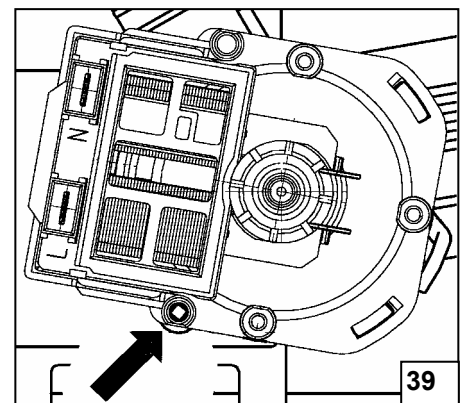

6.9.3 Circulation pump

Access to the pump is from the base of the appliance:

- a. Remove the two screws which secure the pump to the base.
- b. Detach the circulation pump assembly from the base.
- c. Loosen the clamps and detach the hoses from the pump (Fig. 40).
- d. Detach the cover.
- e. Detach the wiring connectors.
- f. Remove the circulation pump assembly.

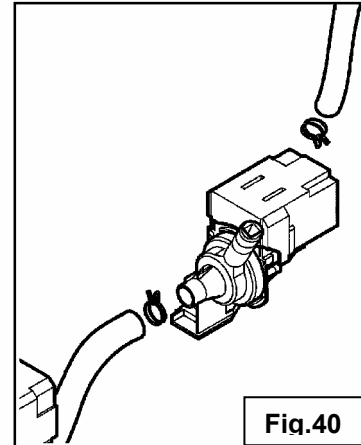

6.9.4 Drain filter body

- a. Remove the rear cabinet shell.
- b. Lay the appliance face-down.
- c. Remove the circulation pump (if present).
- d. Detach the hoses from the filter body.
- e. Remove the screws which secure the front shell to the base. (Fig.41)
- f. Raise the base in order to detach the filter body from the front shell.
- g. Release the tabs which anchor the filter body to the base. (Fig.37)
- h. Remove the drain pump.
- i. Remove the filter body.

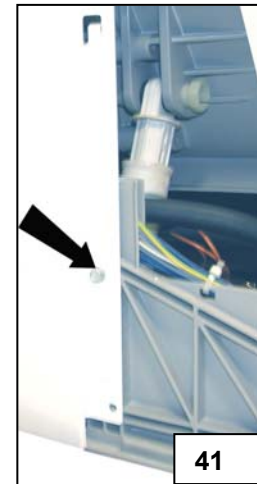

6.9.5 Base

- a. Remove the rear cabinet shell.
- b. Remove the pins which secure the dampers to the base.
- c. Cut the fixing ties and detach the wiring.
- d. Lay the appliance face-down.
- e. Detach the drain hose.
- f. Remove the lateral screws which secure the front shell to the base. (Fig.41)
- g. Remove the lateral screws which secure the front shell to the base. (Fig.42)
- h. Raise the base and remove the filter body.
- i. Remove the base.

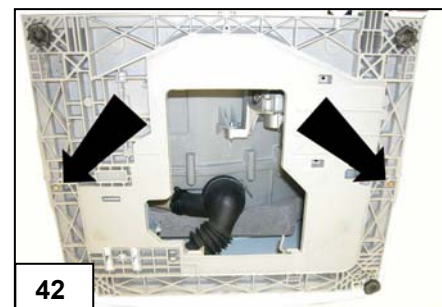

After re-assembly, connect the wiring correctly to the base and secure using new wiring ties.

6.10 Front cabinet shell

- a. Remove the top.
- b. Remove the control panel.
- c. Remove the door.
- d. Detach the bellows seal from the front panel.
- e. Remove the two screws which secure the door delay device to the front panel.
- f. Remove the rear shell
- g. Detach the circulation hose (if present) from the front shell. (Fig.43)
- h. Replace the rear shell, leaving a gap of 1-2 cm in order to remove the lateral screws which secure the front shell to the base. (Fig.44)
- i. Re-position the rear shell completely and re-tighten the screws which secure the upper cross-member to the rear cabinet shell.
- j. Re-tighten the screws which secure the rear shell to the base.
- k. Lay the appliance on its rear panel, preferably on a sheet of cardboard to protect the surface.
- l. Remove the screws which secure front shell to the base from the bottom of the appliance. (Fig.42)
- m. Remove the screws which secure the upper crosspiece to the front cabinet shell.
- n. Lift the crosspiece and slide the front cabinet shell from the base.

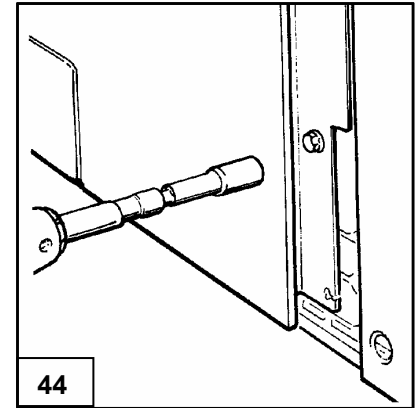
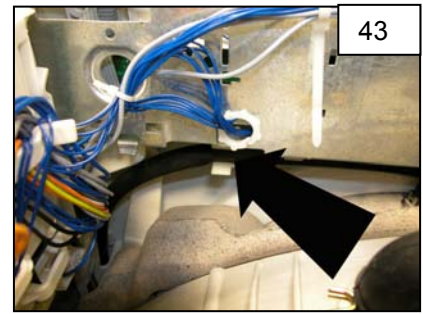

When re-assembling:

- Replace the front cabinet shell and check that it is correctly inserted into the guides in the base.
- Fix the screws of the base from the bottom of the appliance.
- Place the appliance in the upright position, taking care not to damage the structure.
- Replace the screws which secure the upper crosspiece to the front cabinet shell.
- Remove the screws which secure the upper crosspiece to the rear cabinet shell.
- Slide the rear cabinet shell outwards about two centimeters.
- Tighten the lateral screws which secure the front cabinet shell to the base.
- Remove the rear cabinet shell and replace the internal components removed in previous steps.
- Replace the rear shell.
- Replace the door, the door delay device, the bellows seal, the control panel and the top.

The following components are attached to the front cabinet shell:

- *the support brackets for the feet (using two screws)*
- *the drain filter access panel*

It is not necessary to remove the cabinet shell in order to access these components.