

This drawing contains confidential information and is the property of Electrolux, without whose permission it may not be copied, shown or handed to a third party or otherwise used and it is to be returned promptly upon request to the design owner, who is responsible for the drawing.

Items shown in this drawing must not contain substances that are banned according to Directive, 2002/95/EC, the RoHS Directive (Lead, Cadmium, Mercury, hexavalent Chromium, PBB and PBDE), or substances classified as "Banned" or "Restricted" according to the Electrolux Restricted Materials List.

230V

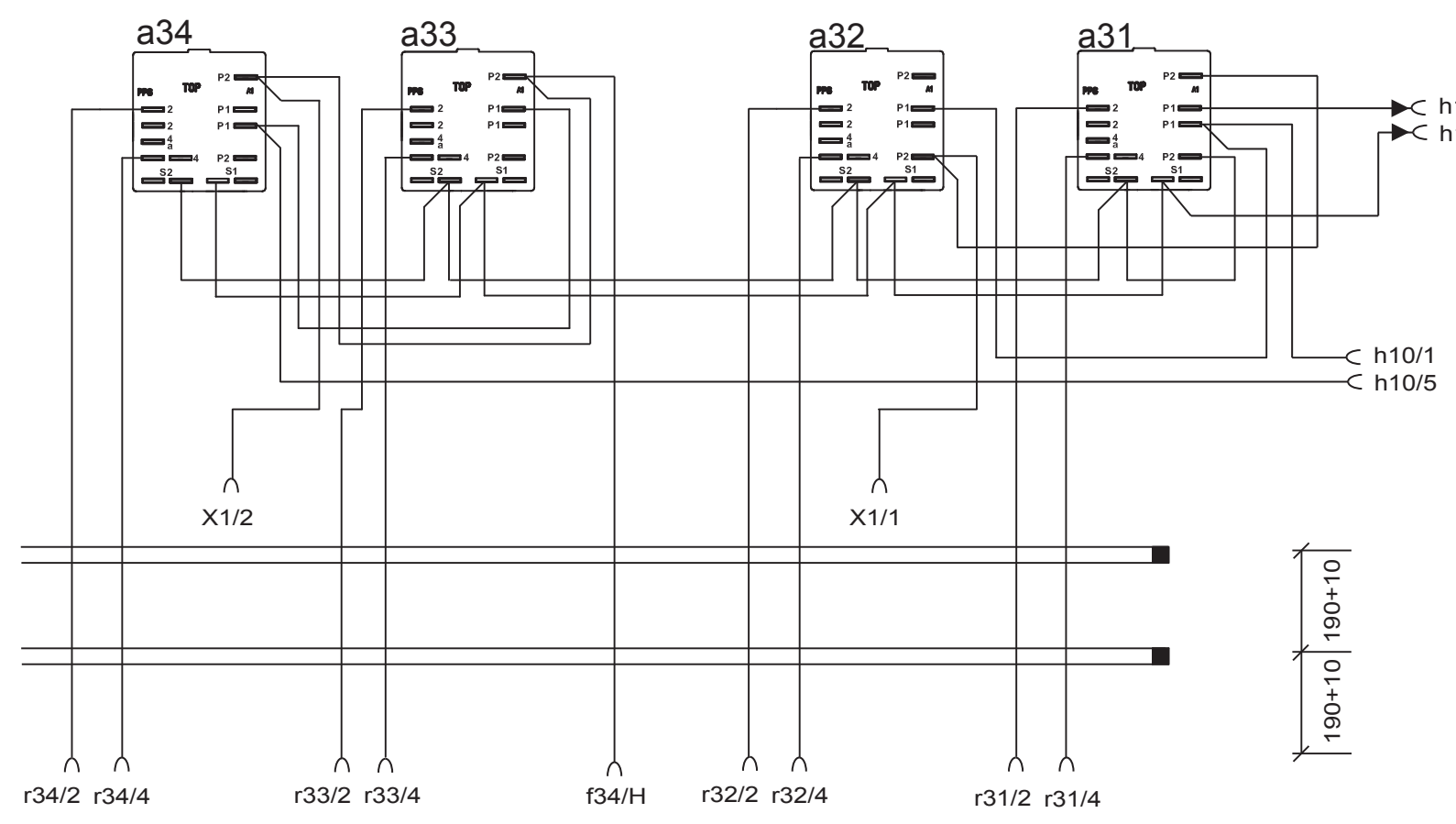

Pos.	contact	structure explanation	colour	cross-section
01	h10/1 - a31/P1 - a32/P1	194-140-195-140-194	blue	1,0-0,75
02	h10/5 - a34/P1 - a33/P1	194-500-195-140-194	blue	1,0-0,75
03	X1/1 - a32/P2 - a31/P2	194-600-195-140-194	black	1,0-0,75
04	X1/2 - a34/P2 - a33/P2 - f34/H	194-650-195-140-195-650-194	grey	1,0-0,75
05	a31/4 - (r31/4)	194-850-194	re	0,75
06	a31/2 - (r31/2)	194-850-194	re	0,75
07	a32/4 - (r32/4)	194-900-194	wh	0,75
08	a32/2 - (r32/2)	194-900-194	wh	0,75
09	a33/4 - (r33/4)	194-700-194	black	0,75
10	a33/2 - (r33/2)	194-700-194	black	0,75
11	a34/4 - (r34/4)	194-650-194	br	0,75
12	a34/2 - (r34/2)	194-650-194	br	0,75
13	a31-P2 - a32/S2 - a31/S2 - a33/S2 - a34/S2	194-140-195-140-195-400-195-140-194	blue	0,75
14	a34/S1 - a33/S1 - a32/S1 - a31/S1 - h1	194-140-195-400-195-140-195-140-194	blue-ye	0,75
15	a31/P1 - h1	194-140-194	ye	0,75

single wires

Pos.	contact	structure explanation	colour	min. cross-section	no.
01	h10/2 - X1/4	194-600-194	bl	1,0	
02	X1/4 - h10/4 - h30/N	194-600-195-750-175	bl - or	1,0 - 0,75	
03	f34/H - f33/H - f32/H - f31/H	184-300-195-350-195-300-194	grey	0,75	
04	X1/PE - PE Protection Box	194-600-182	greenyellow	1	

- f34/S > wire from h30 RH br
- f33/S > wire from h30 RH black
- f32/S > wire from h30 RH wh
- f31/S > wire from h30 RH re

designation	Elux part no.	
a31	energy regulator front left	389 0824 01
a32	energy regulator rear left	389 0824 01
a33	energy regulator rear right	389 0824 01
a34	energy regulator front right	389 0824 01
* ▶	insulation housing	330 1766 00
	list of crimp contacts	330 2222 00
	list of components	330 5273 00
	material of wire	

B	change of length of wire, add of an insulation housing	S.Holzinger	DGT 67757	2008-09-18
A	First edition	S.Holzinger	DGT 65196	2008-07-09
POS.	MODIFICATIONS	SIGNATURE	REQUEST	DATE
MATERIAL	MODEL	SCALE	EUROPEAN METHOD	
TREATMENT	WEIGHT	DESIGN USERS	REPLACES	
	- Kg.		DERIVED FROM	
DESIGN OWNER	DRN	CHD S.Holzinger	SUPPLY SPECIFICATIONS	
DGT	DATE	APPR S.Holzinger		
	2008-07-09		TITLE wiring switch panel	
		NUMBER	REV B	
		349 6016	SHEET 1/1	

349 6016 00	-	-	-	-	FS Hob, 230V, 4xSingle
VARIANT NUMBER	REPLACED NUMBER	POS.	MODEL	DESIGN USERS	CHANGES FROM THE BASE NUMBER

GENERAL TOLERANCES  
ANGLES  
LENGTHS AND DIAMETERS

A3 [DF04]