

220 - 240 VAC

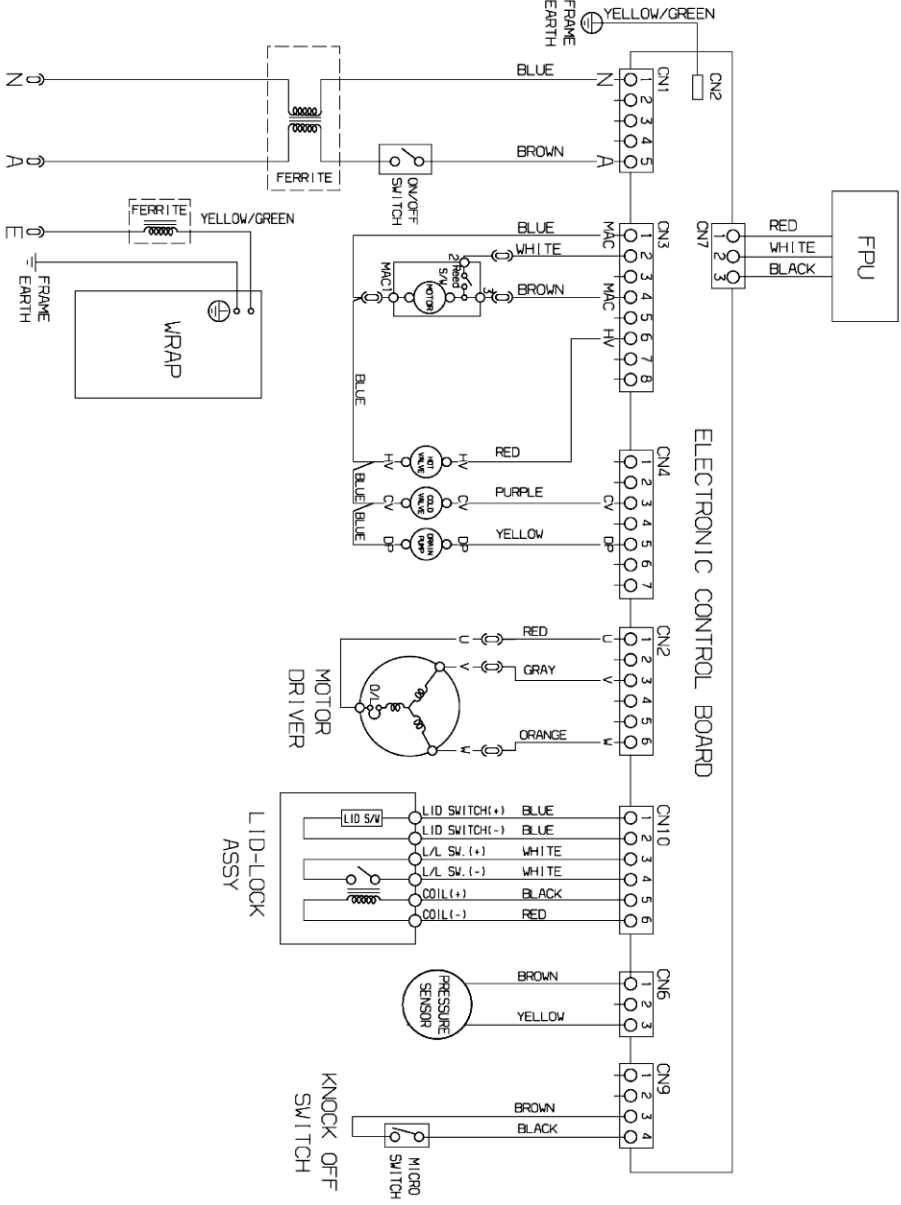

ELECTRONIC CONTROL BOARD

NOTES:  
 MAC = MOTOR BRAKE ACTUATOR CLUTCH  
 CV = COLD VALVE  
 HV = HOT VALVE  
 ECO = ECO VALVE  
 SV = SOFTENER VALVE  
 DP = DRAIN PUMP  
 RP = RECIFE PUMP

MODEL:  
 22S750M\* . FLT1105\*  
 KAT105\* . WLT1105\*  
 WAT105\* . GLT1115\*  
 FLT1115\* . WLT1115\*  
 22S950\* . KLT1105\*