



















APPARECCHIATURE					
V2	VENTOLA FORNO 1	BPn	BLOCCO PORTAFASTON	C5	COMMUTATORE TERMOSTATO 2
V3	VENT. TANGENZIALE FORNO 1	T1	TERMOSTATO DI SICUREZZA FORNO 1	L10	LUCE FORNO 2
R1	RESISTENZA GRILL FORNO 1	T3	TERMOSTATO FORNO 1	L11	SPIA TERMOSTATO COMMUTATORE T4
R2	RESISTENZA CIELO FORNO 1	L1	LUCE FORNO 1	T2	TERMOSTATO DI SICUREZZA FORNO 2
R3	RESISTENZA SUOLA FORNO 1	L12	SPIA BISTECCHIERA 2	T4	TERMOSTATO FORNO 2
R4	RESISTENZA VENTOLA FORNO 1	L11	SPIA BISTECCHIERA 1	V5	VENT. TANGENZIALE FORNO 2
R11	RESISTENZA BISTECCHIERA 1	L7	SPIA ROSSA COMMUTATORE FORNO 1	V6	MOTORE GRILL FORNO 2
R12	RESISTENZA BISTECCHIERA 2	L8	SPIA GIALLA TERMOSTATO FORNO 1	R8	RESISTENZA GRILL FORNO 2
C1	COMMUTATORE FORNO 1	EP	OROLOGIO A DISPLAY	R9	RESISTENZA CIELO FORNO 2
C2	COMMUTATORE TERMOSTATO FORNO 1	ACn	ACCENDITORI GAS FUOCHI	R7	RESISTENZA SUOLA FORNO 2
C12	COMMUTATORE BISTECCHIERA 2	M1	MICRO INTERRUTTORE PORTA FORNO 1		
C11	COMMUTATORE BISTECCHIERA 1	Pn	CONSENSO ACCENSIONE FUOCHI		

COLORI			
WH	BIANCO <i>White</i>	YE	GIALLO <i>Yellow</i>
GY	GRIGIO <i>Grey</i>	GY	VERDE <i>Green</i>
BU	BLU <i>Blue</i>	OG	ARANCIO <i>Orange</i>
VT	VIOLA <i>Violet</i>	BN	MARRONE <i>Brown</i>
BK	NERO <i>Black</i>	GNYE	GIALLO / VERDE <i>Yellow/Green</i>
RD	ROSSO <i>Red</i>	WHRD	BANCO/ROSSO <i>White/Red</i>

SIMBOLOGIA			
	CONTATTO AUSILIARIO (NA)		CONDENSATORE
	CONTATTO AUSILIARIO (NC)		RESISTENZA ELETTRICA
	CONTATTO POTENZA		MOTORE ELETTRICO
	FINECORSA		BOBINA TIMER
	TERMOSTATO (NA)		CONTATTO TIMER
	TERMOSTATO (NC)		AVVISATORE ACUSTICO
	COMMUTATORE ROTATIVO		BOBINA CONTATTORE
	PRESA A SPINA TIPO FASTON		LAMPADA
	PULSANTE DI ACCENSIONE GAS		MORSETTO TERRA

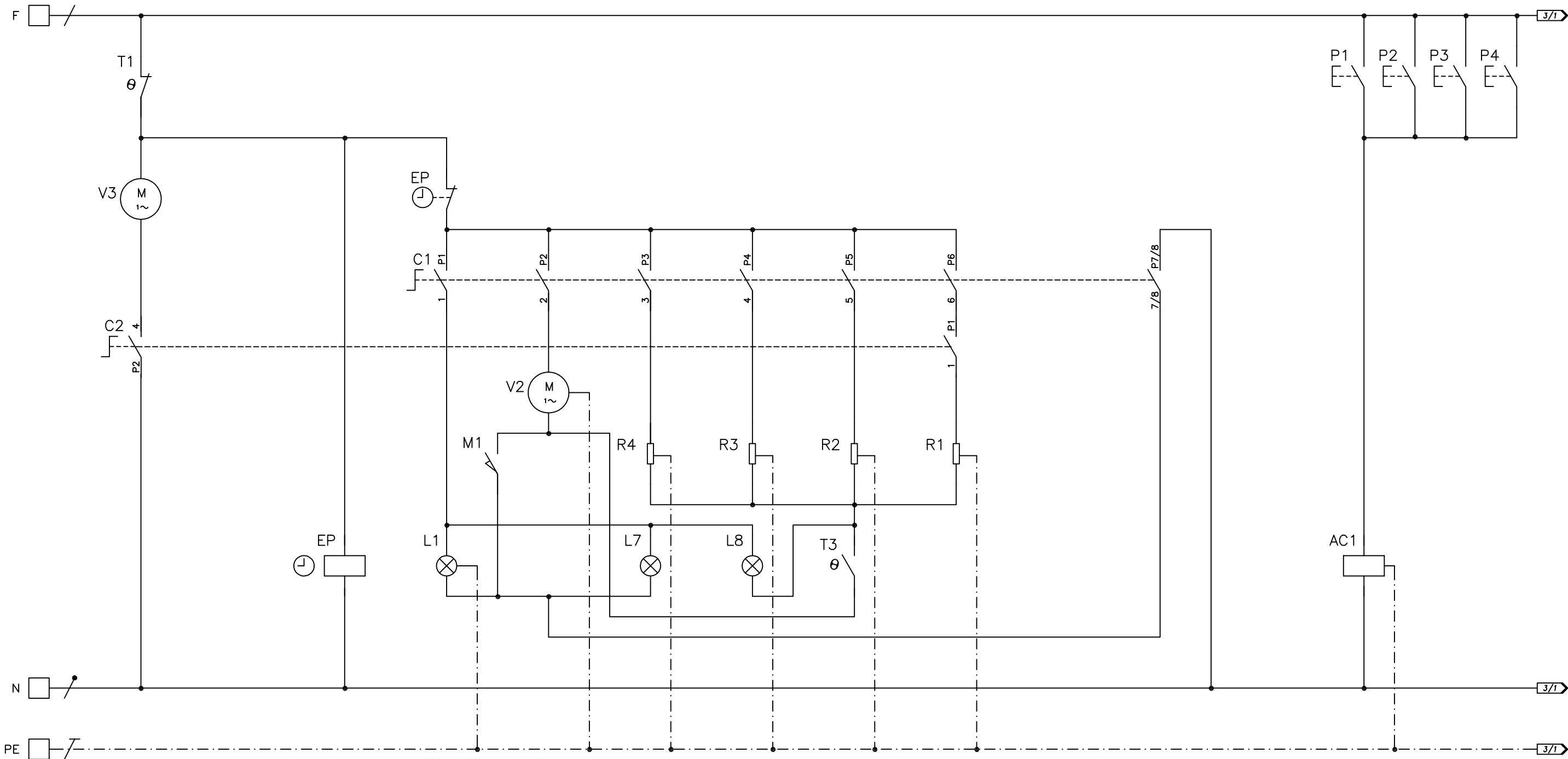

M1 = Micro aperto a sportello forno aperto.

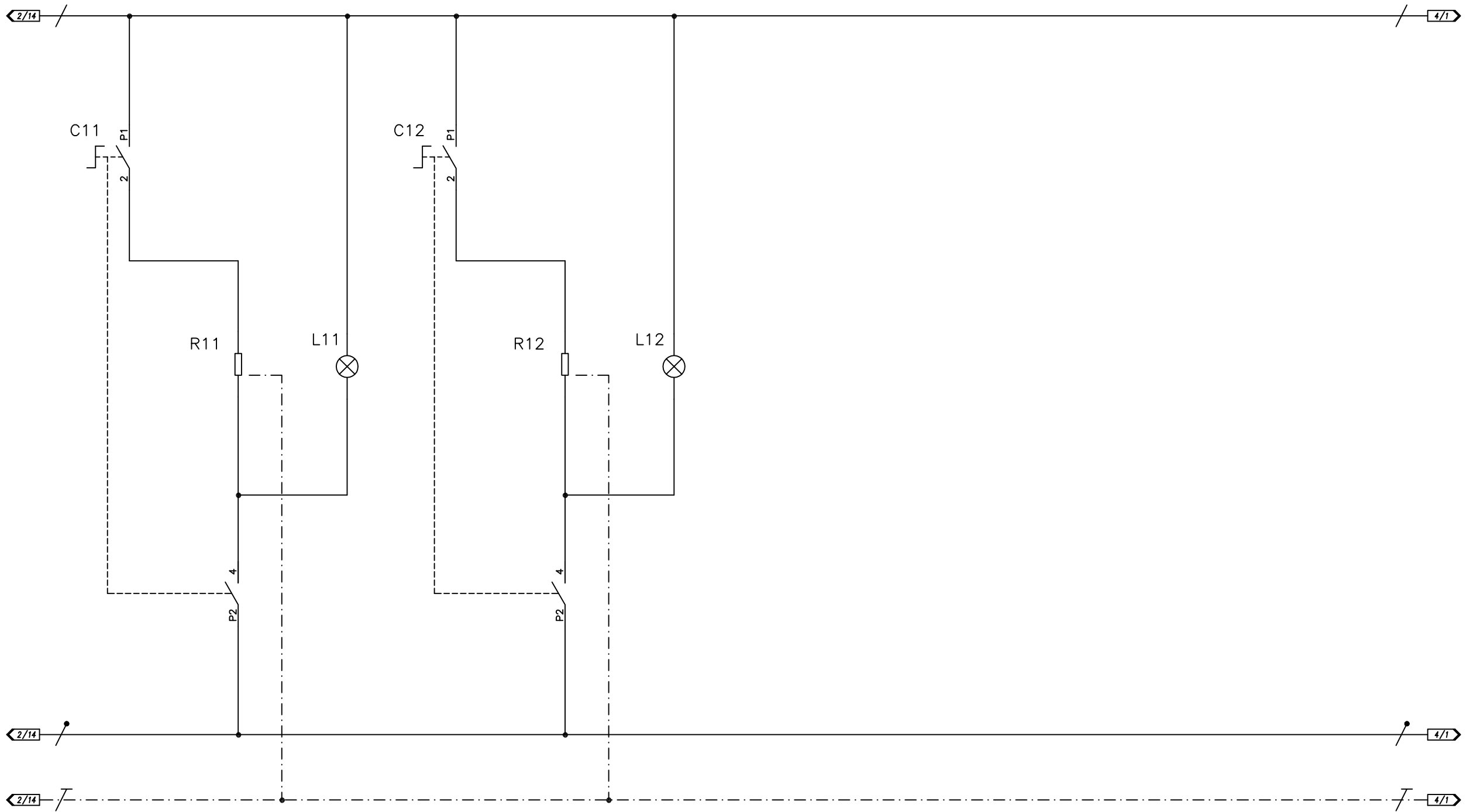

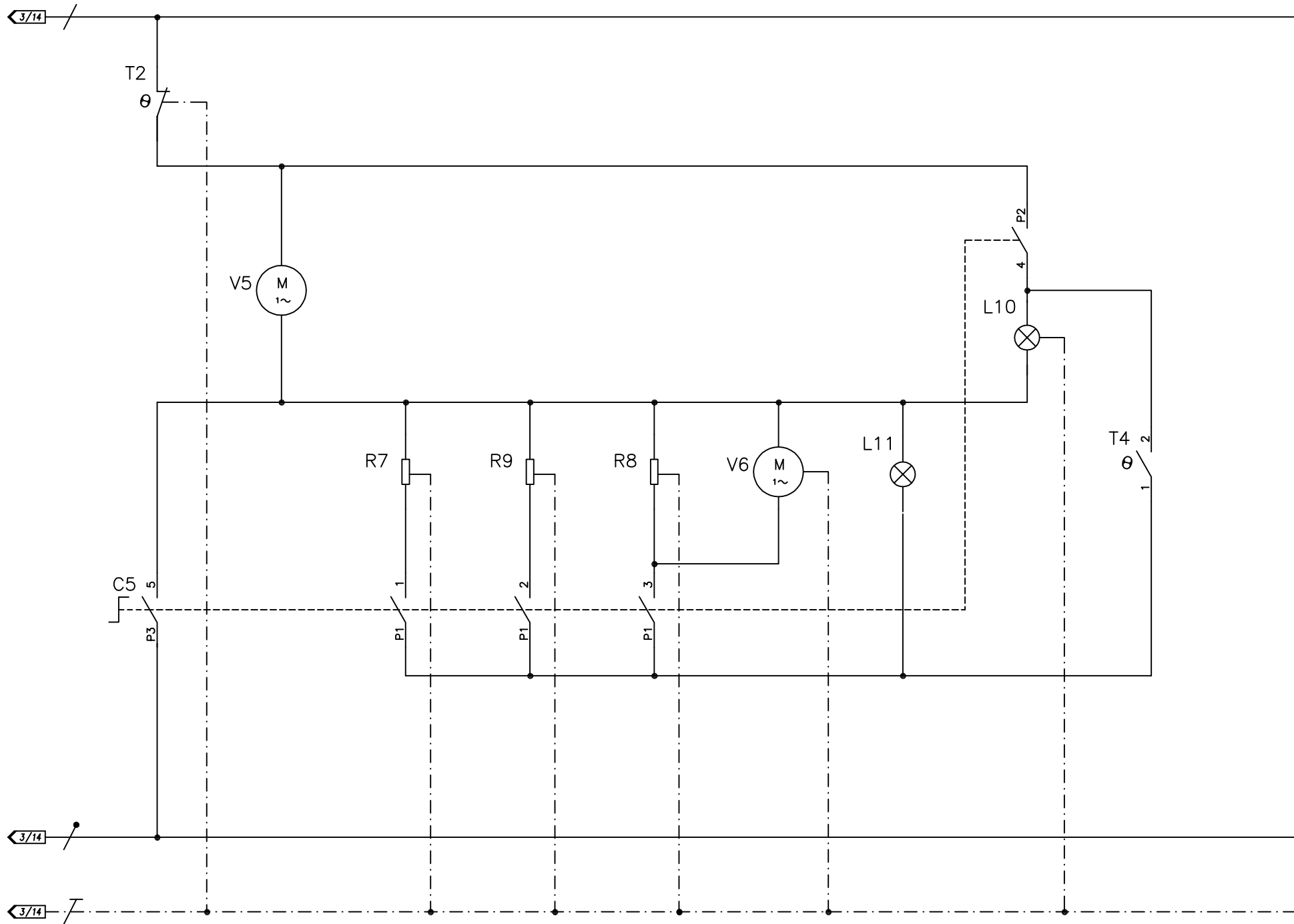

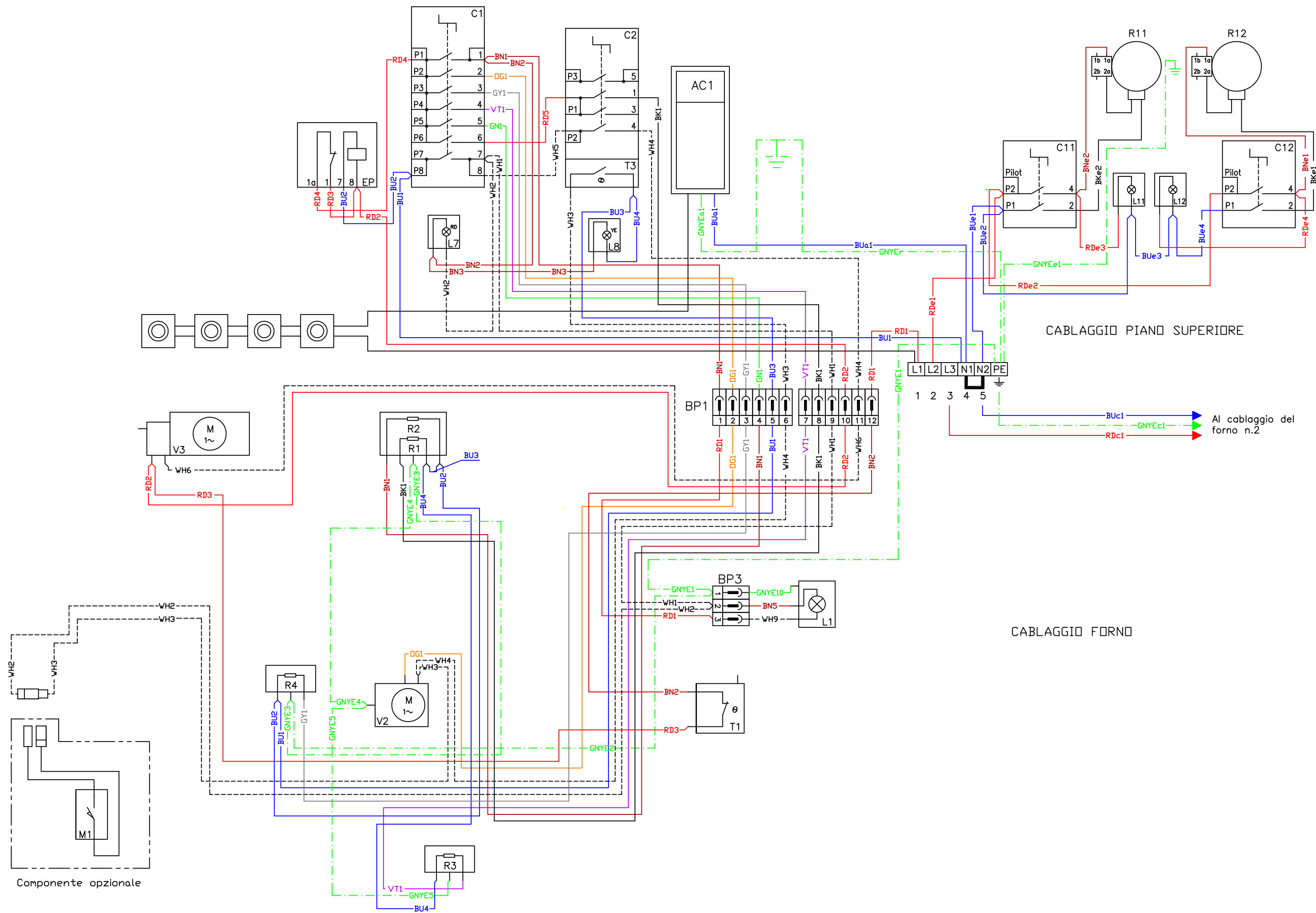

CABLAGGIO PIANO SUPERIORE

CABLAGGIO FORNO

Al cablaggio del
forno n.2

Componente opzionale

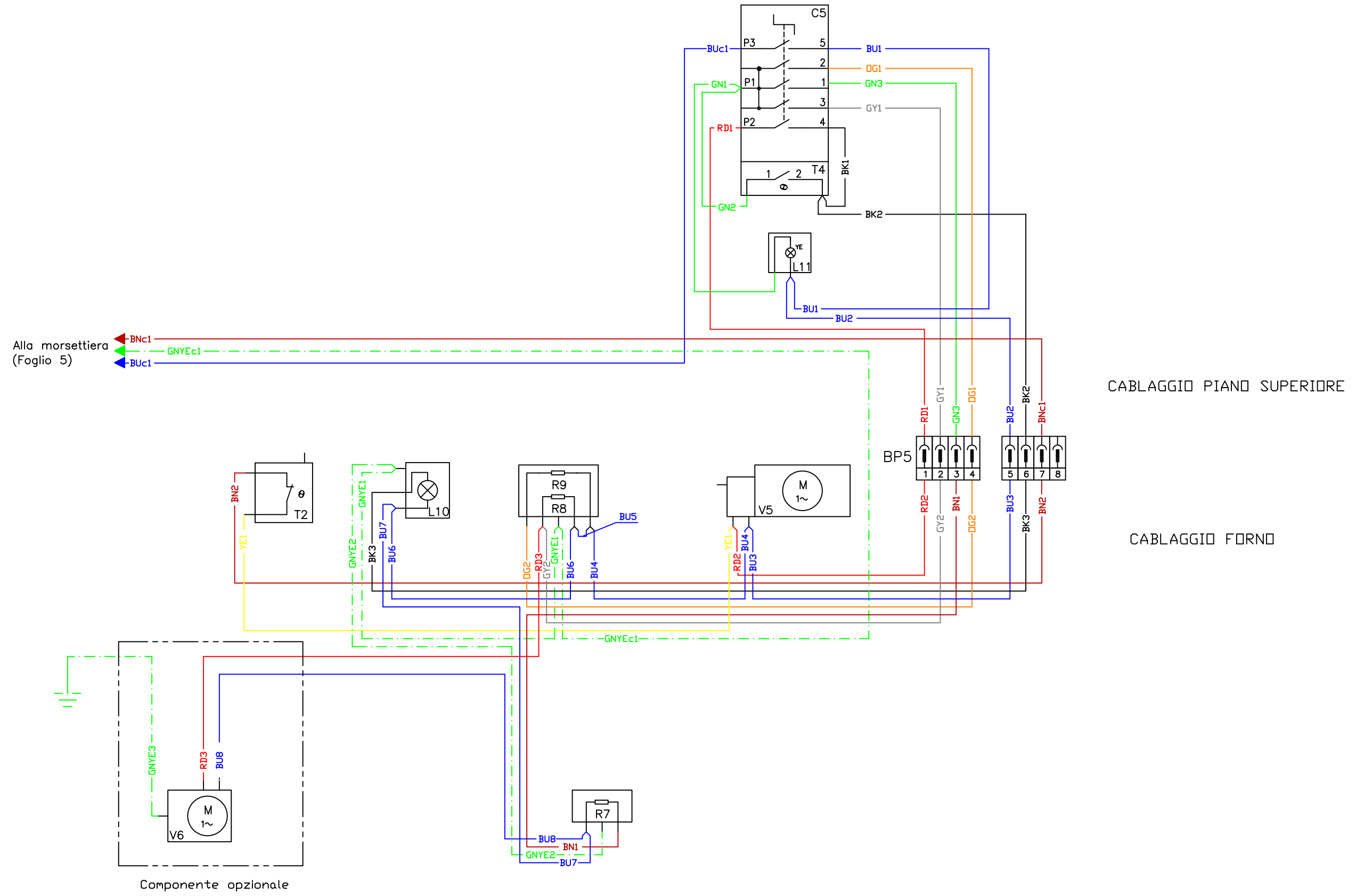

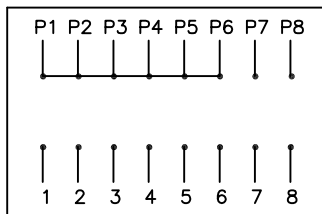
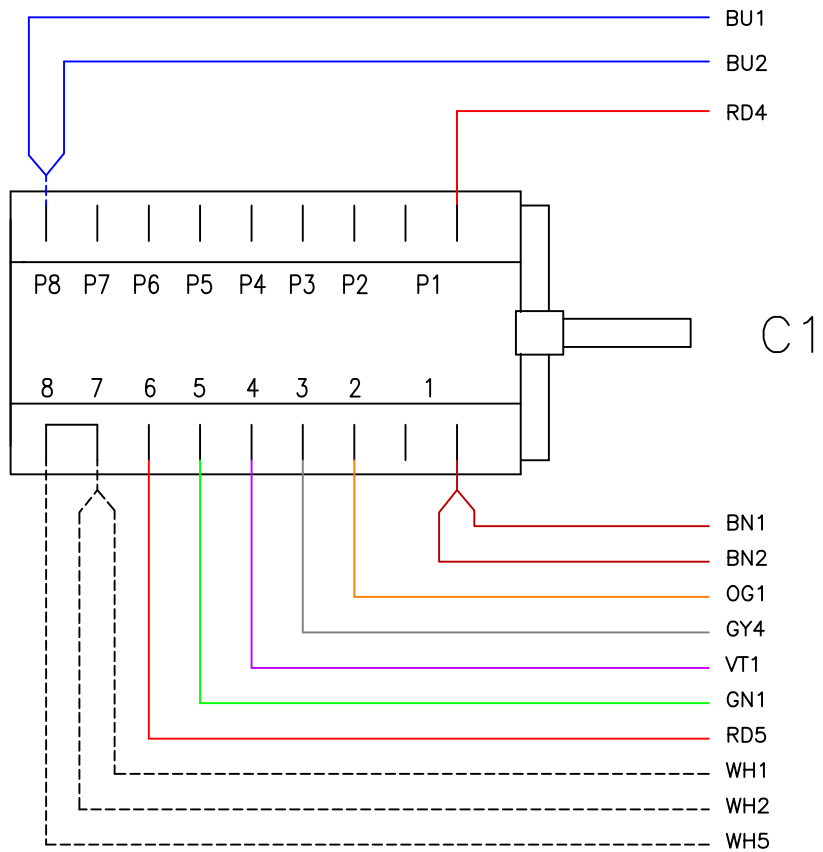

POS 0

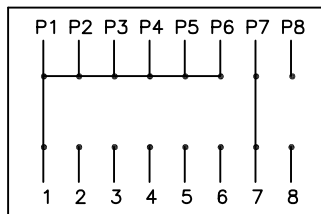

POS 1

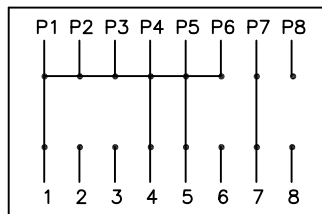

POS 2

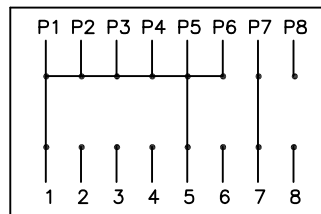

POS 3

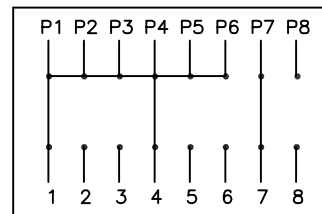

POS 4

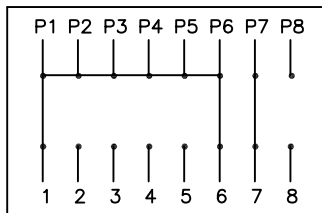

POS 5

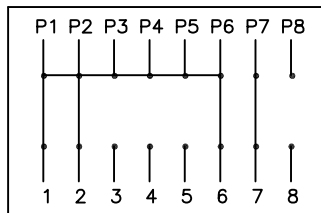

POS 6

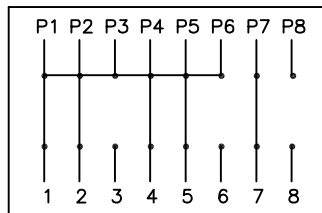

POS 7

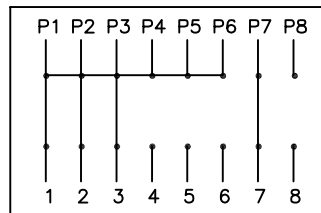

POS 8

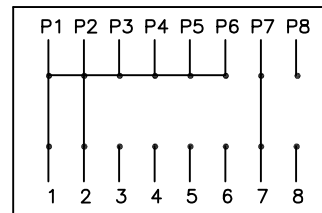

POS 9

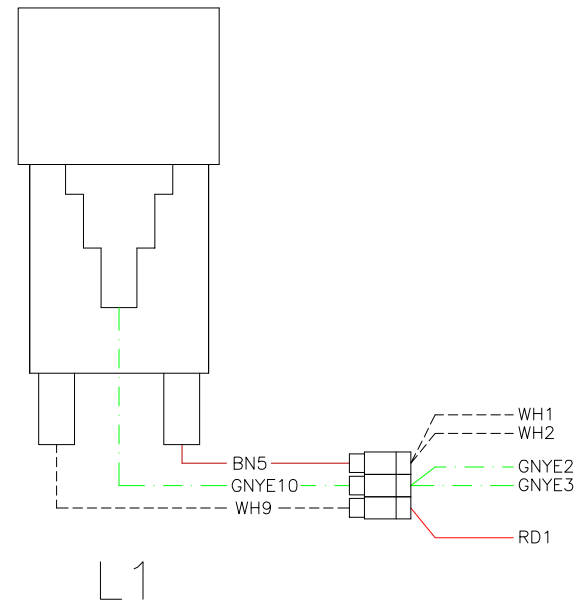
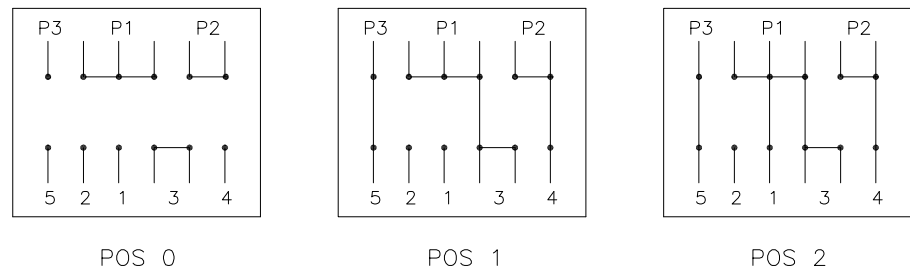
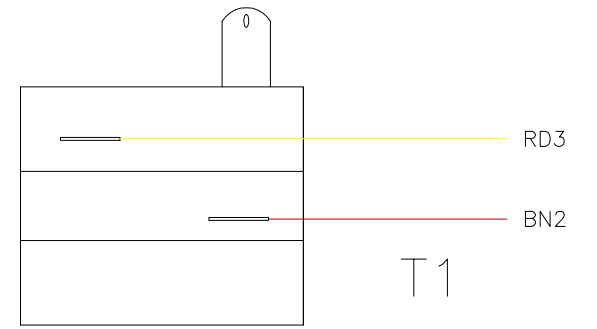
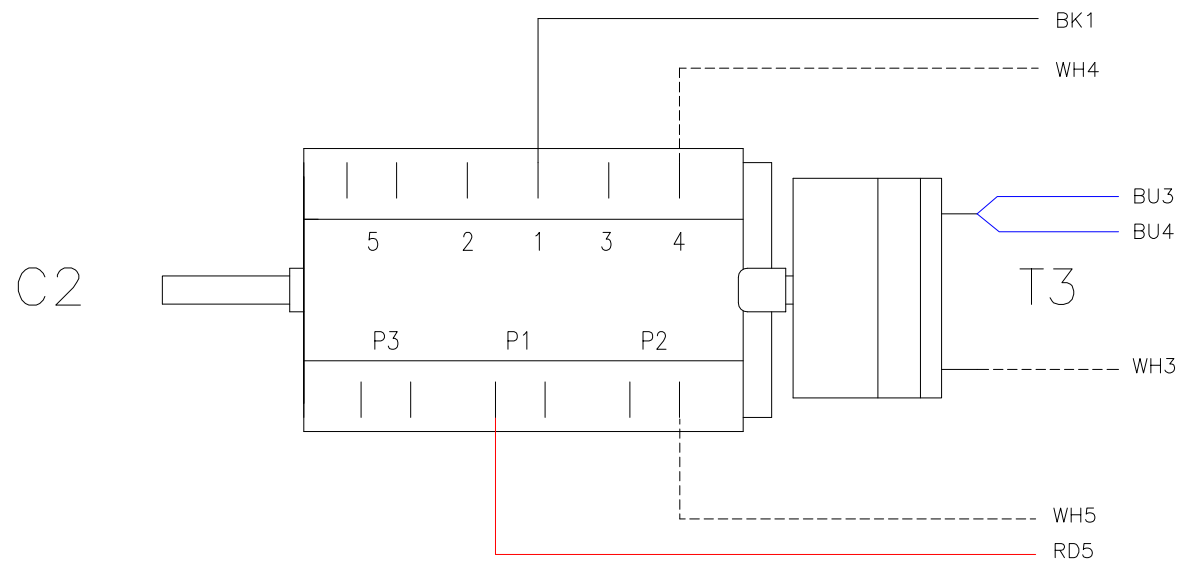

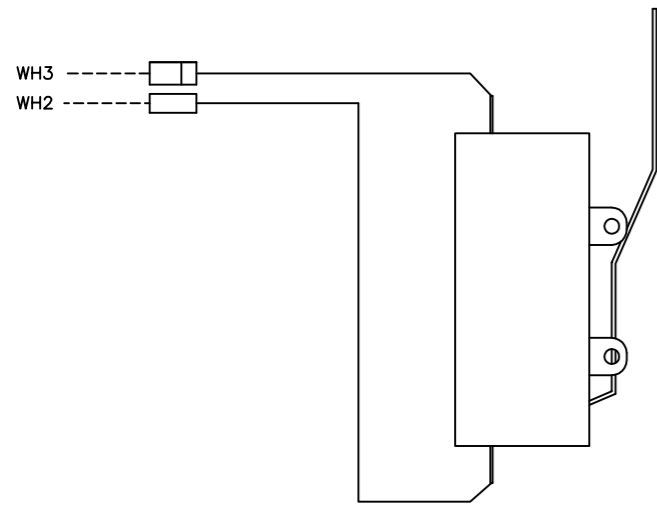

M1 (componente opzionale)

MORSETTIERA

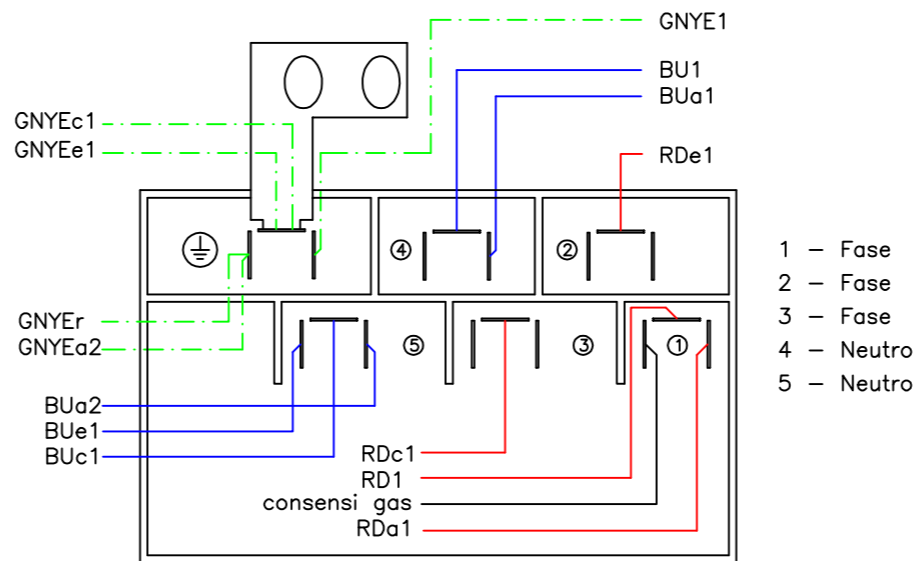

Nota:

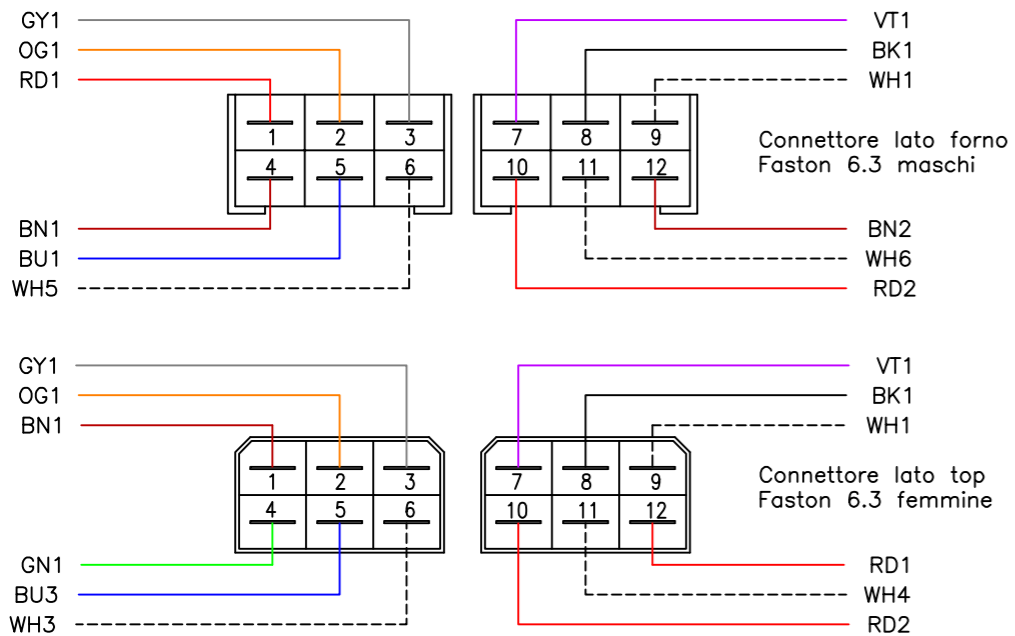
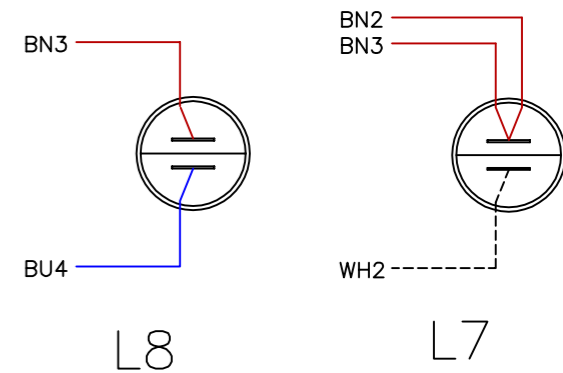

BP1

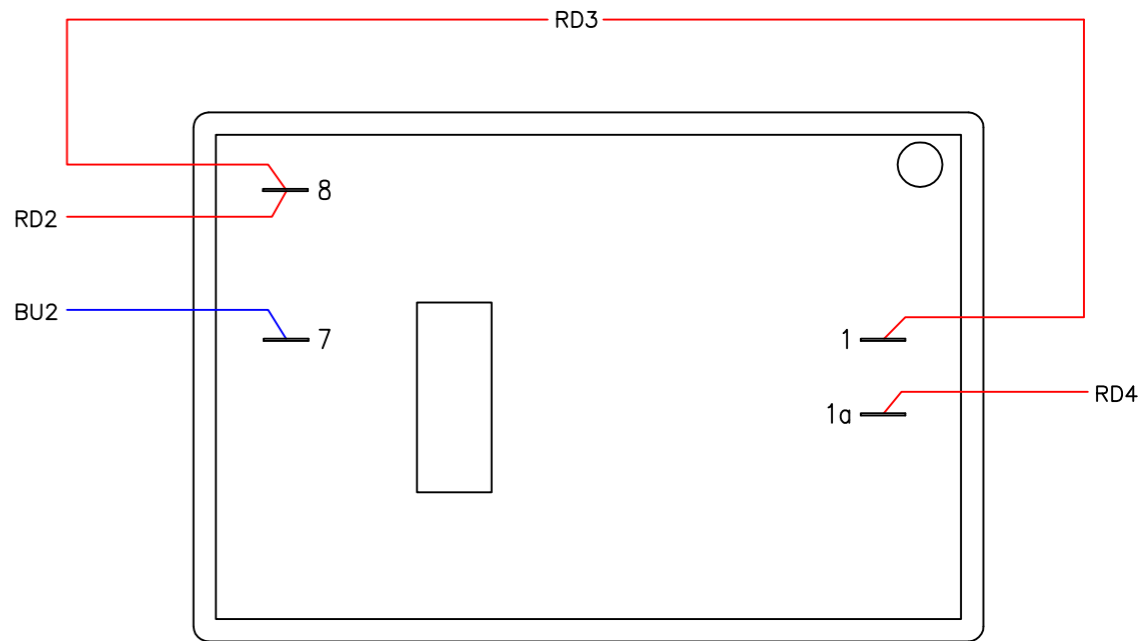

EP

R1 - R2

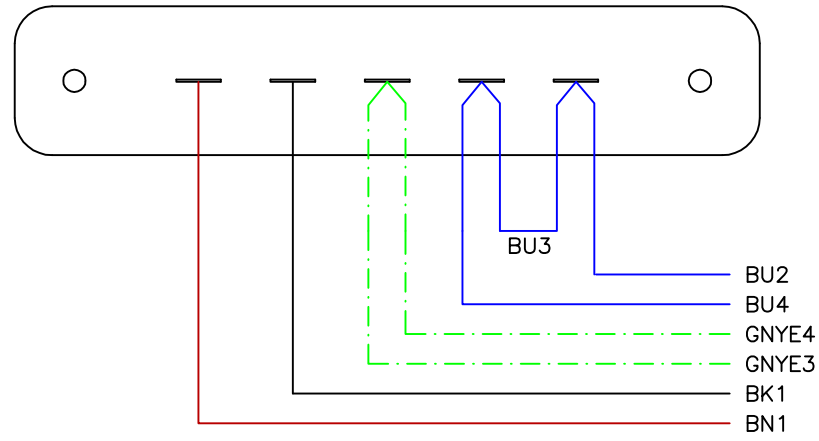

R3

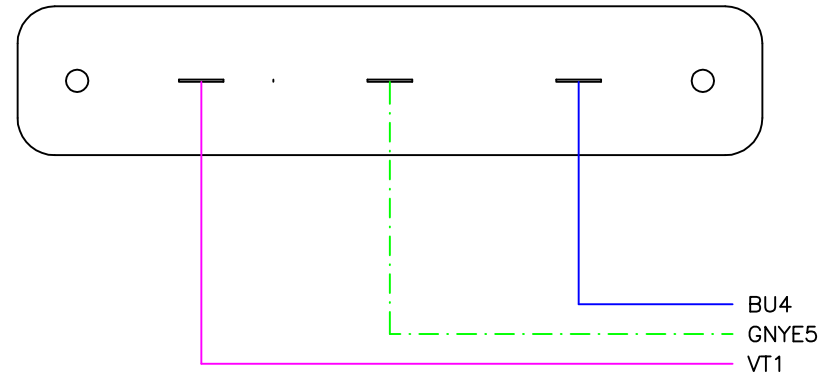

R4

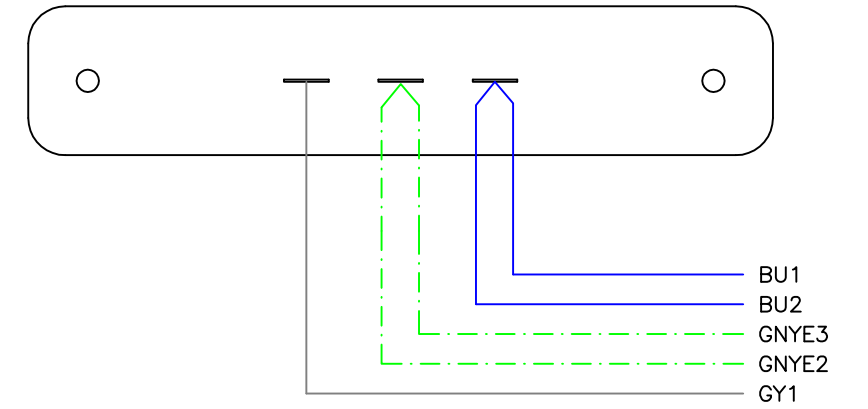

V2

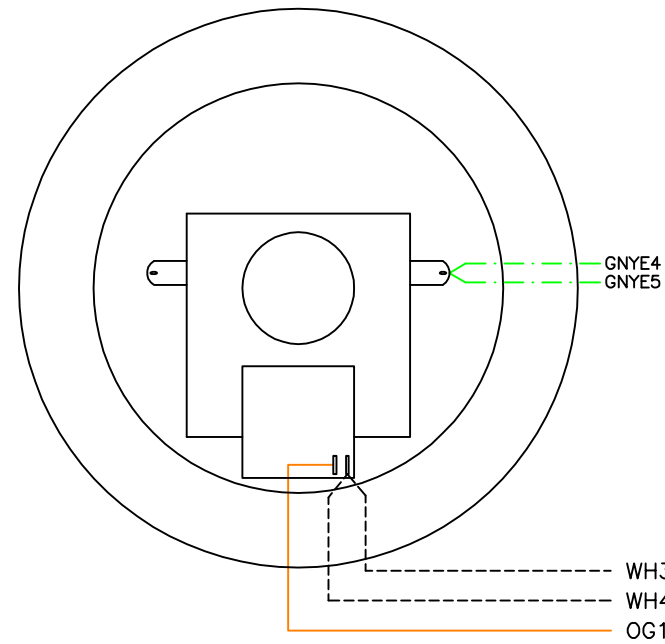

V3

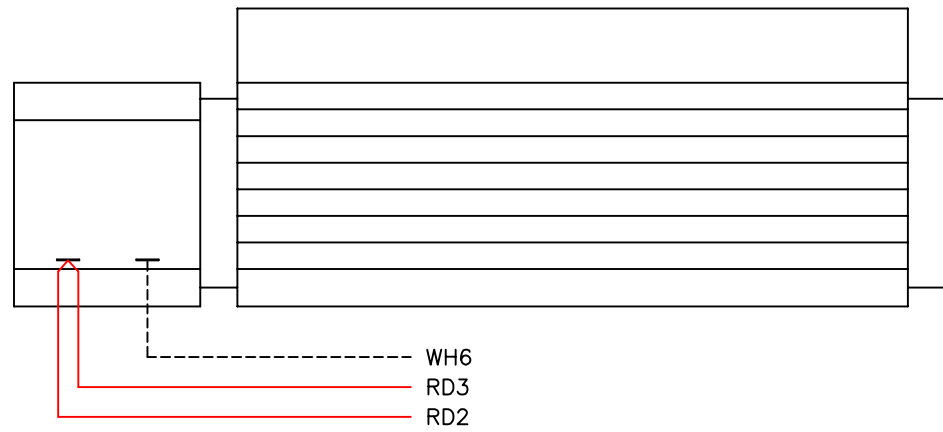

R11

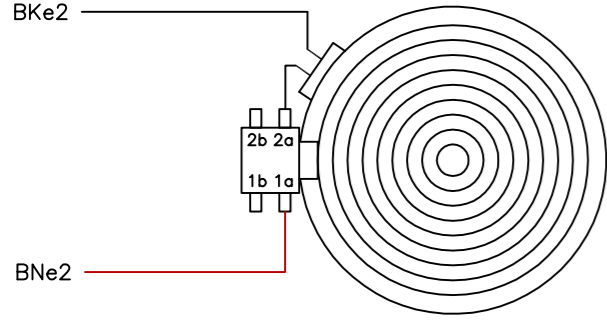

R12

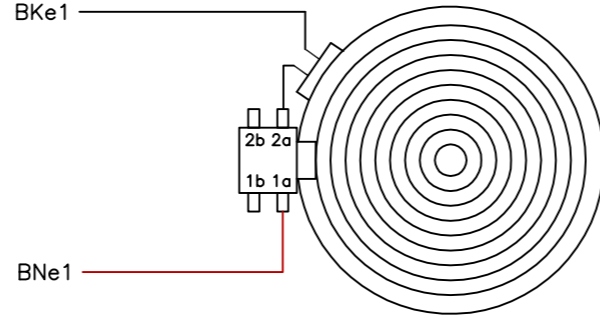

C11

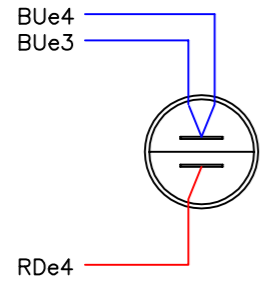
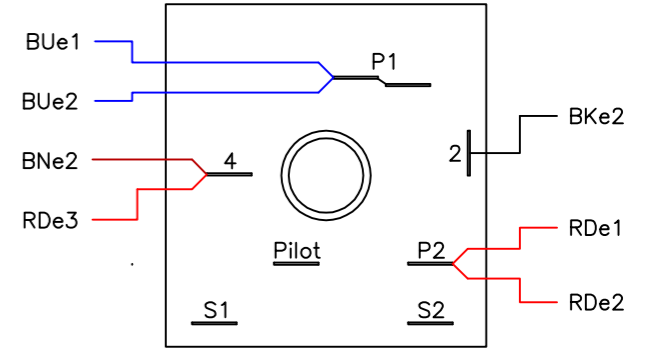

L12

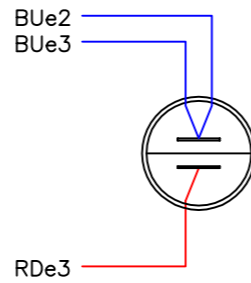

L11

C12

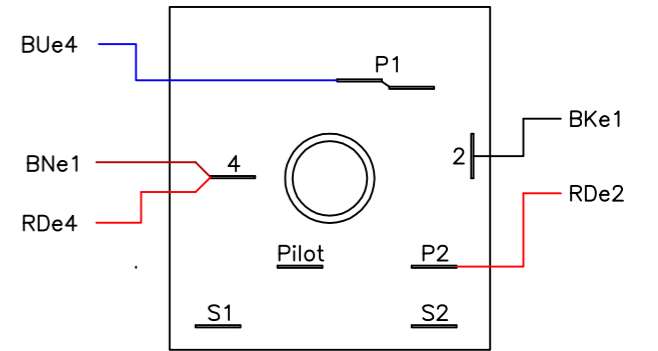

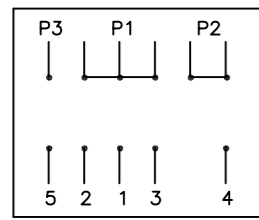
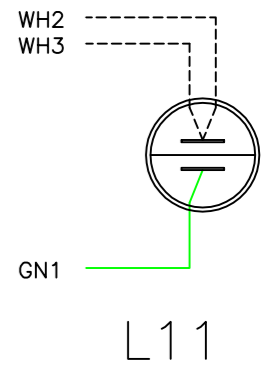
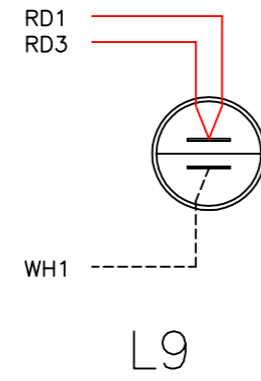
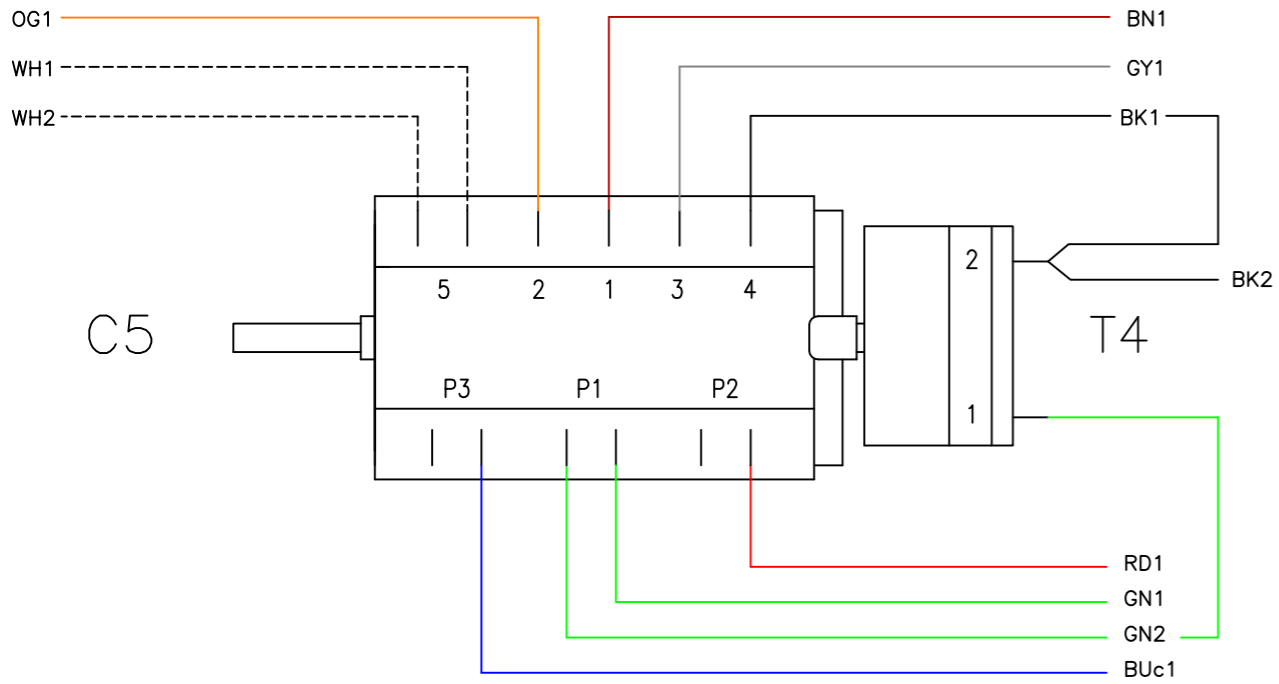

POS 0

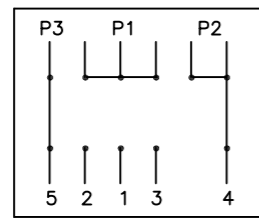

POS 1

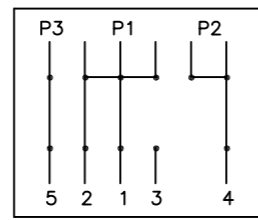

POS 2

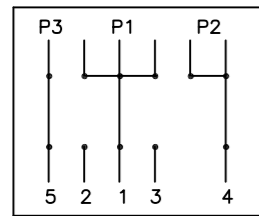

POS 3

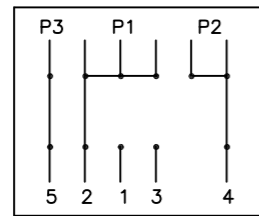

POS 4

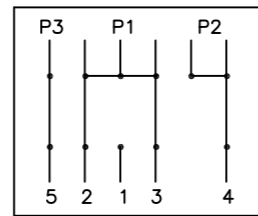

POS 5

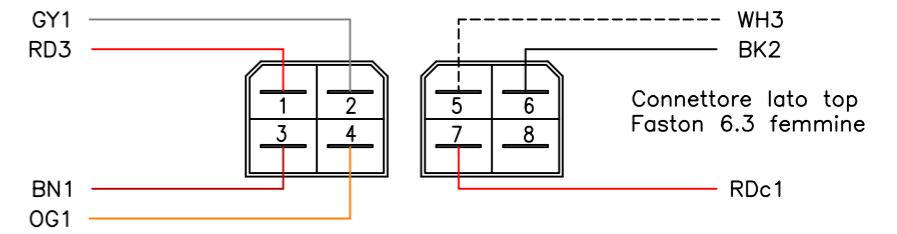
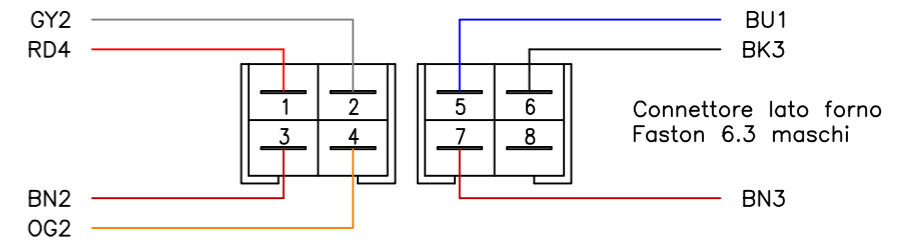

BP5

R8 - R9

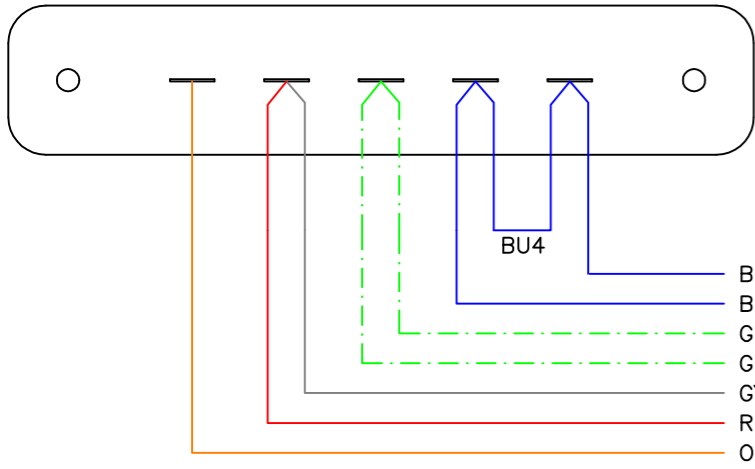

R7

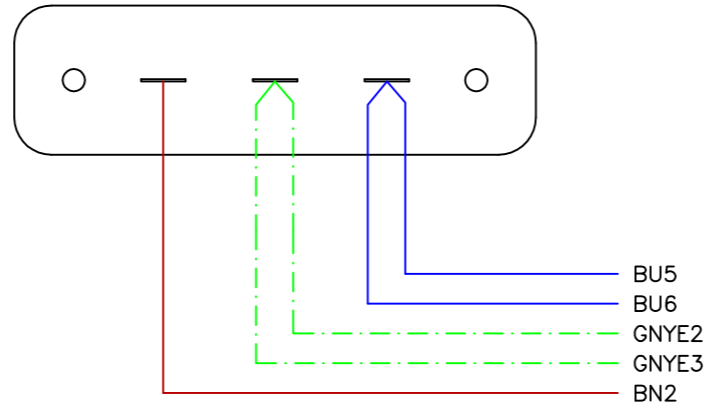

V5

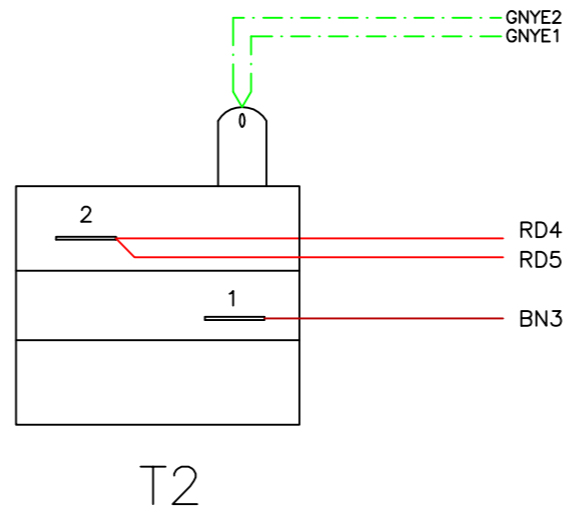
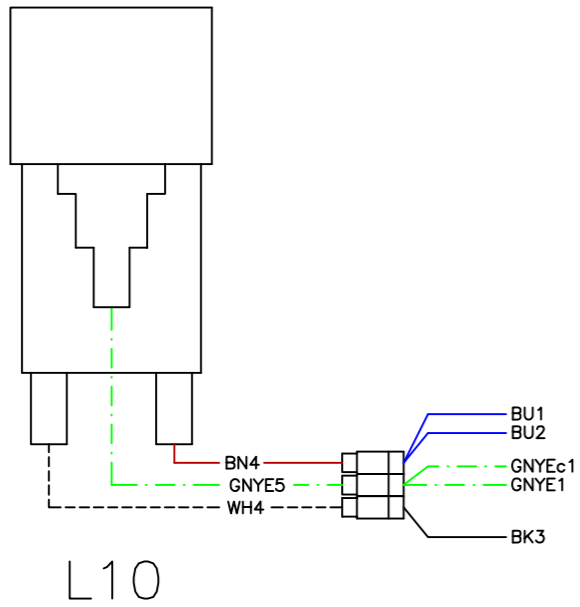
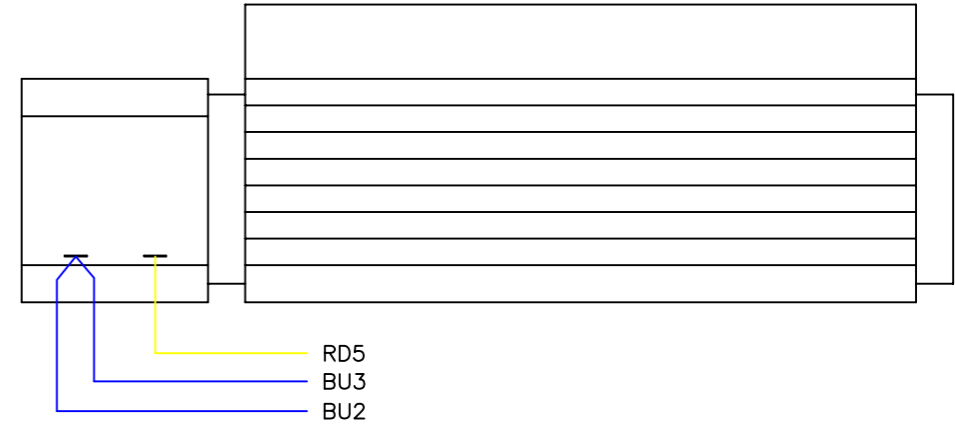

V6

