

--- PILOT LAMP
 --- VIOLET
 --- GREY
 --- WHITE
 --- RED
 --- LIGHT BLUE
 --- BLUE
 --- BROWN
 --- BLACK
 --- TIMER

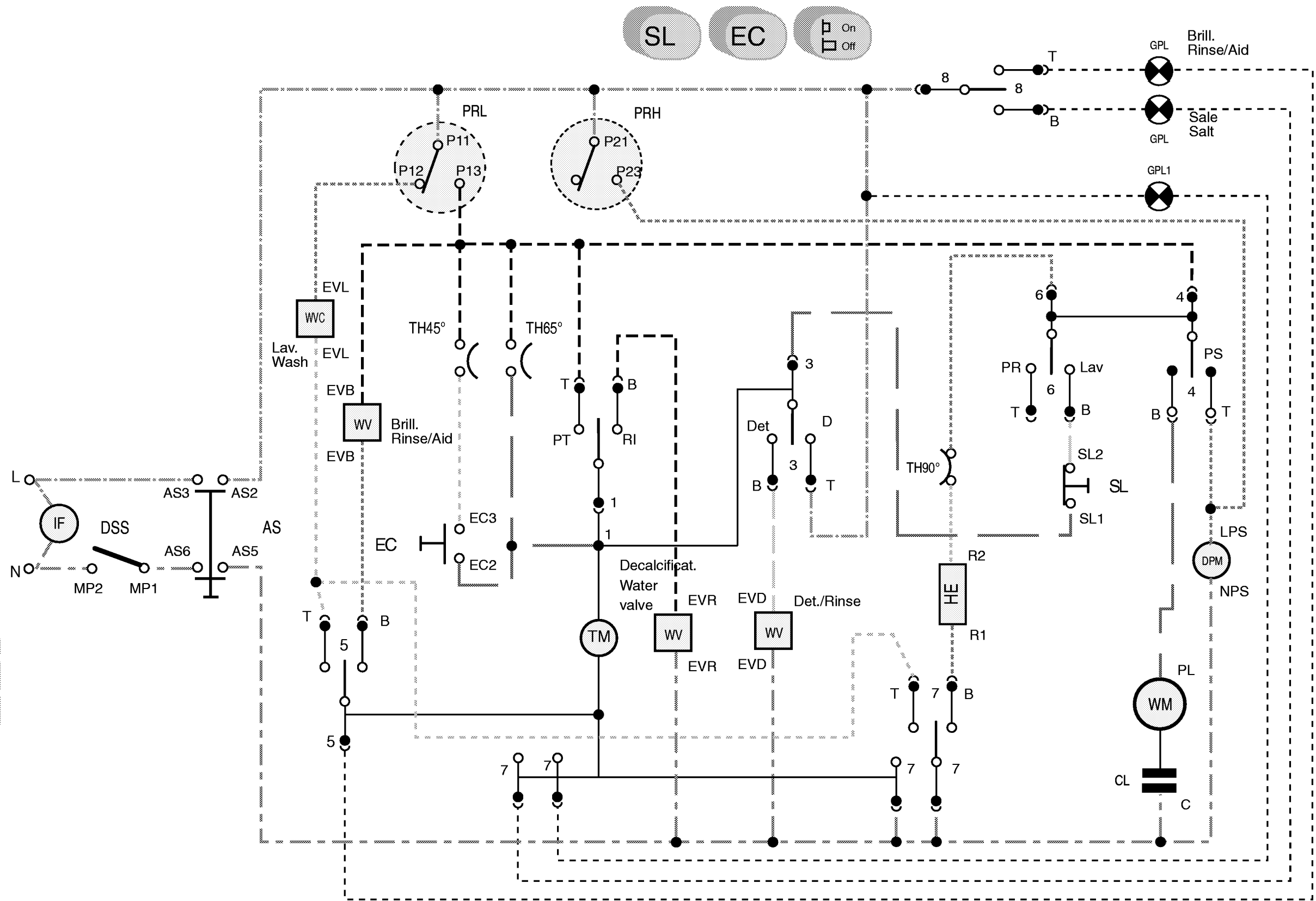

SL EC On Off

P09MO30000021

- | | | | | | |
|------|-----------------------|-------------------------|--------------|-------------------------|-----------------------|
| TM | Motorino timer | Timer motor | WV | Elettrovalvola | Water valve |
| EM | Termostop | Thermostop | CC | Condensatore centrifuga | Spin capacitor |
| IF | Filtro antisturbo | Interference filter | CL | Condensatore lavaggio | Wash capacitor |
| RSS | Stop acqua in vasca | Spin delay button | HE | Resistenza lavaggio | Heating element |
| SDE | Esclusione centrifuga | No spin button | RE | Relè | Relay |
| LWS | Mezzo carico | Half load button | AS | Pulsante On - Off | ON - OFF button |
| e | Energy saving | Eco button | ER | Pulsante 4° Risciacquo | Extra rinse button |
| CWS | Lavaggio a freddo | Cold wash button | TH(10°-90°C) | Termostato regolabile | Adjustable thermostat |
| PRL | Pressostato liv.basso | Low level pressostat | TH | Termostato fisso | Klixon |
| PRH | Pressostato liv.alto | High level pressostat | M | Motore | Main motor |
| WVC | Elettrovalvola fredda | Water valve (cold fill) | SM | Motore centrifuga | Spin-dry motor |
| WVW | Elettrovalvola calda | Water valve (hot fill) | WM | Motore lavaggio | Wash motor |
| PREH | Pressostato | Pressostat | CU | Modulo elettronico | Control unit |
| DSS | Bloccoporta | Micro delay switch | Z | Temporizzatore | Drying timer |
| DPM | Elettropompa | Drain pump motor | GPL1 | Lampada spia | Pilot lamp |
| SL | Super lavaggio | Extra Washing Button | GPL2 | Lampada oblò | Door pilot lamp |
| EC | Energy saving | | | | |

- MS: SALT MICRO SWITCH
 MB: RINSE AID MICRO SWITCH
 EVD: DETERGENT MAGN. VALVE
 EVB: RINSE AID MAGN. VALVE
 EVR: RESIN MAGN. VALVE
 EVA: WATER MAGN. VALVE
 PL: WASH MOTOR
 PS: DRAIN PUMP
 R: HEATING ELEMENT
 TR: THERMISTOR
 MP: DOOR MICRO-SWITCH
 FL= FLUSSOMETER
 P= PRESSURE SWITCH
 Z: RFI FILTER
 C: CAPACITOR