

bk	black
bn	brown
bu	blue
gd	gold
gn	green
gnye	green/yellow
gy	grey
og	orange
pk	pink
rd	red
sr	silver
tq	turquoise
vt	lilac
wh	white
ye	yellow
B1	PTC/relay
B2	Air sensor - refrigerator
B3	Evaporator sensor - refrigerator
C1	Operating capacitor (if provided)
E19E2	LED
E20	
F1	Clixon (external or internal)
K1	Board
M1	C-S-R motor
S3	Door switch - refrigerator compartment
T3	Compressor

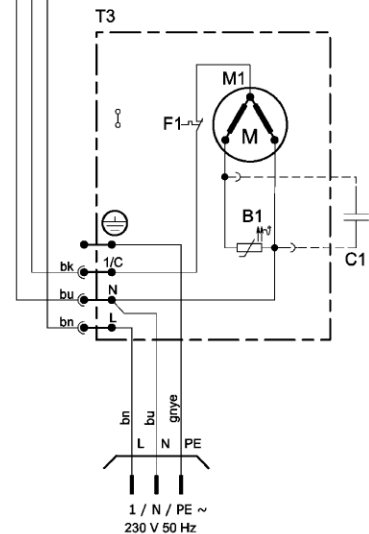

P09LH30000000