

Rotary Sensing Air Vented Dryer - Wiring Diagram

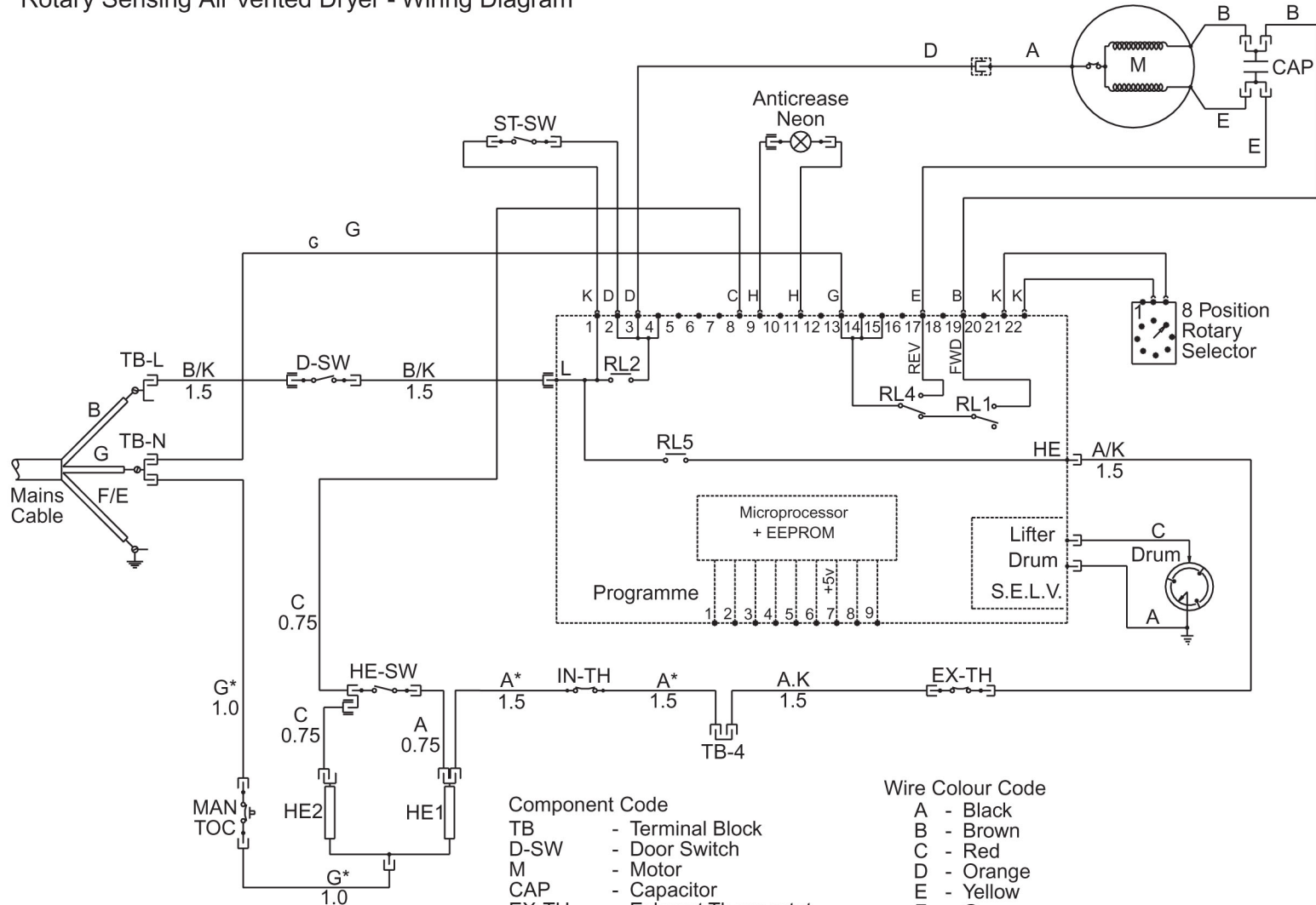

Component Code

TB	- Terminal Block
D-SW	- Door Switch
M	- Motor
CAP	- Capacitor
EX-TH	- Exhaust Thermostat
IN-TH	- Inlet Thermostat
HE	- Heater
ST-SW	- Start Switch
MAN TOC	- Manual Reset Cut-out
HE-SW	- Heat Switch

Wire Colour Code

A	- Black
B	- Brown
C	- Red
D	- Orange
E	- Yellow
F	- Green
G	- Blue
H	- Violet
J	- Grey
K	- White
N/A	- Pink