

E?? (TSK-M8206REQM) TSANN KUEN

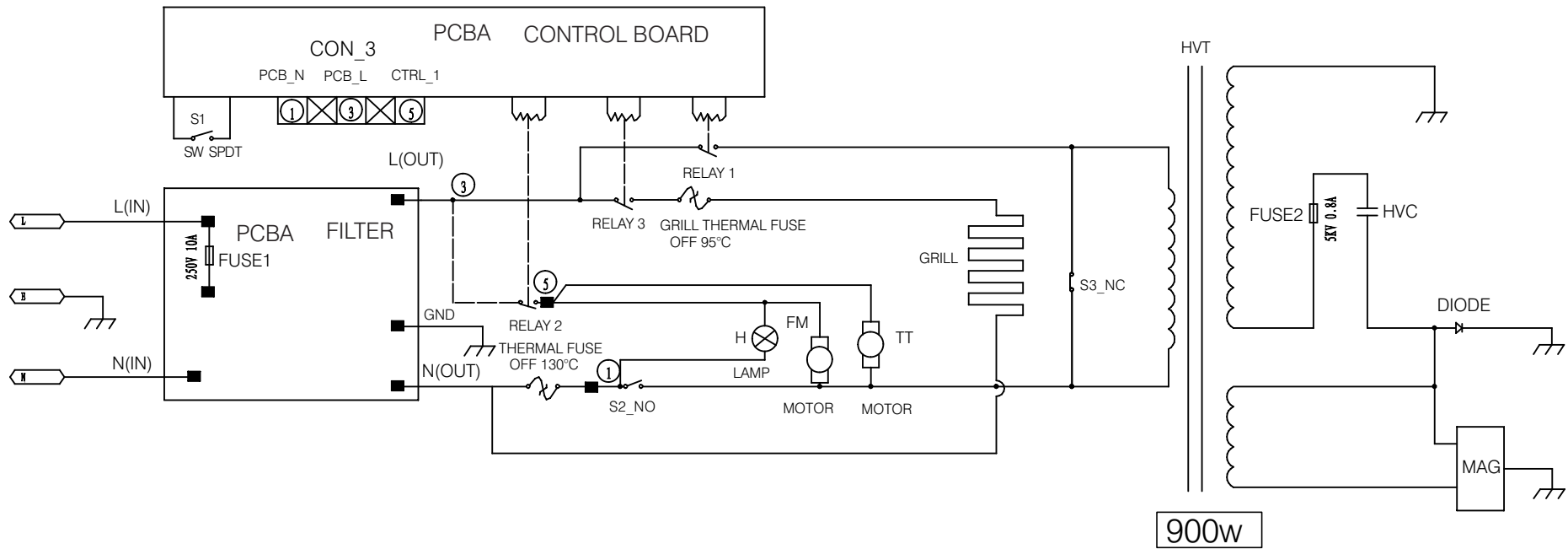

CONTROL BOARD = ELECTRONIC CONTROL PCB
 DIODE = HIGH VOLTAGE DIODE
 FILTER = NOISE FILTER
 FM = FAN MOTOR
 GRILL = GRILL HEATER ELEMENT
 GRILL THERMAL FUSE = GRILL THERMAL PROTECTOR
 GND = EARTH
 FUSE1 = MAIN FUSE
 FUSE2 = HIGH VOLTAGE FUSE
 HVC = HIGH VOLTAGE CAPACITOR

H = OVEN LAMP
 HVT = HIGH VOLTAGE TRANSFORMER
 L(IN) = MAIN PHASE
 MAG = MAGNETRON
 N(IN) = MAIN NEUTRAL
 RELAY1 = POWER RELAY
 RELAY2 = FAN/LAMP RELAY
 RELAY3 = GRILL RELAY
 S1 = LOGICAL SWITCH
 S2 = PRIMARY SWITCH
 S3 = MONITOR SWITCH
 THERMAL FUSE = OVEN THERMAL PROTECTOR