

E4 (M2801MEQ/CEQ) TSANN KUEN

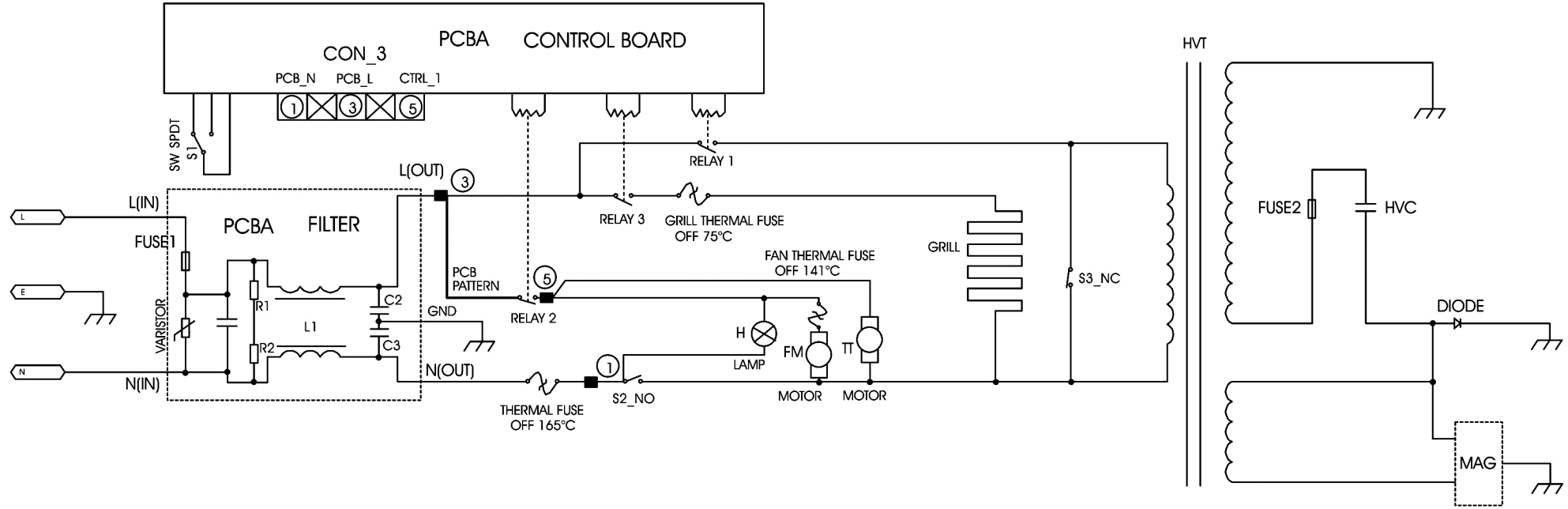

900w

CONTROL BOARD = ELECTRONIC CONTROL PCB  
 DIODE = HIGH VOLTAGE DIODE  
 FAN THERMAL FUSE = FAN MOTOR THERMAL PROTECTOR  
 FILTER = NOISE FILTER  
 FM = FAN MOTOR  
 GRILL = GRILL HEATER ELEMENT  
 GRILL THERMAL FUSE = GRILL THERMAL PROTECTOR  
 GND = EARTH  
 FUSE1 = MAIN FUSE  
 FUSE2 = HIGH VOLTAGE FUSE  
 HVC = HIGH VOLTAGE CAPACITOR

H = OVEN LAMP  
 HVT = HIGH VOLTAGE TRANSFORMER  
 L(IN) = MAIN PHASE  
 MAG = MAGNETRON  
 N(IN) = MAIN NEUTRAL  
 RELAY1 = POWER RELAY  
 RELAY2 = FAN/LAMP RELAY  
 RELAY3 = GRILL RELAY  
 S1 = LOGICAL SWITCH  
 S2 = PRIMARY SWITCH  
 S3 = MONITOR SWITCH  
 THERMAL FUSE = OVEN THERMAL PROTECTOR