

SCHEMATIC

NOTE: CONDITION OF OVEN

1. DOOR CLOSED.
2. PLUGGED IN OVEN.
3. NOTHING APPEARS ON DISPLAY.

Note:

AC CORD CONNECTION

BRN : BROWN

BLU : BLUE

G-Y : GREEN AND YELLOW STRIPE

/15 : SECTIONAL AREA OF 1.5mm² MIN.

★ Indicates components with potential above 250 V.

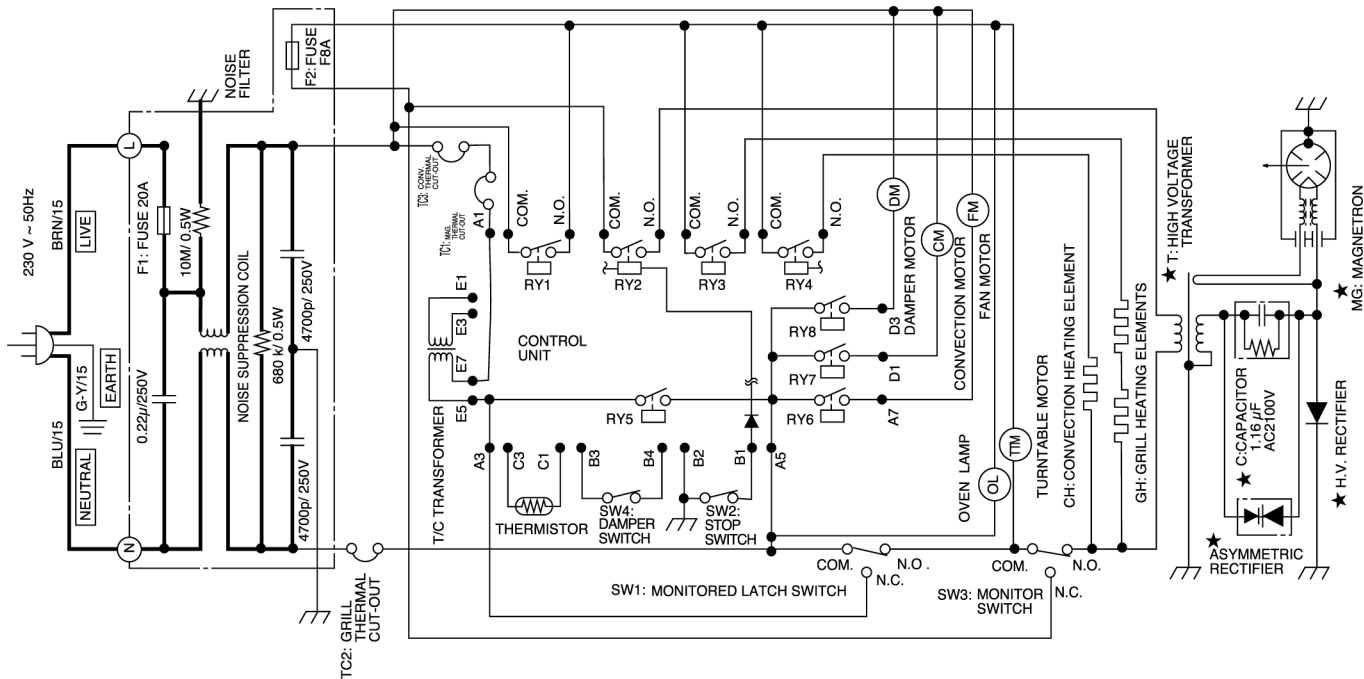

Oven Schematic-OFF Condition right after the oven is plugged in.