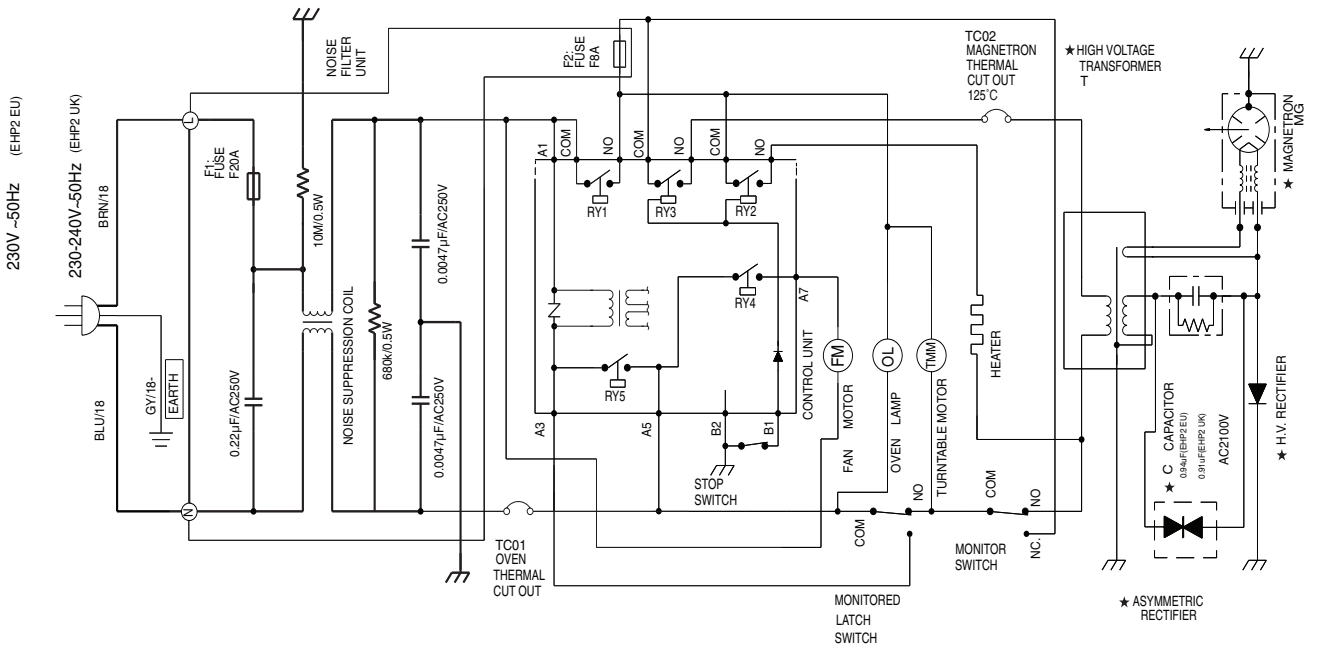
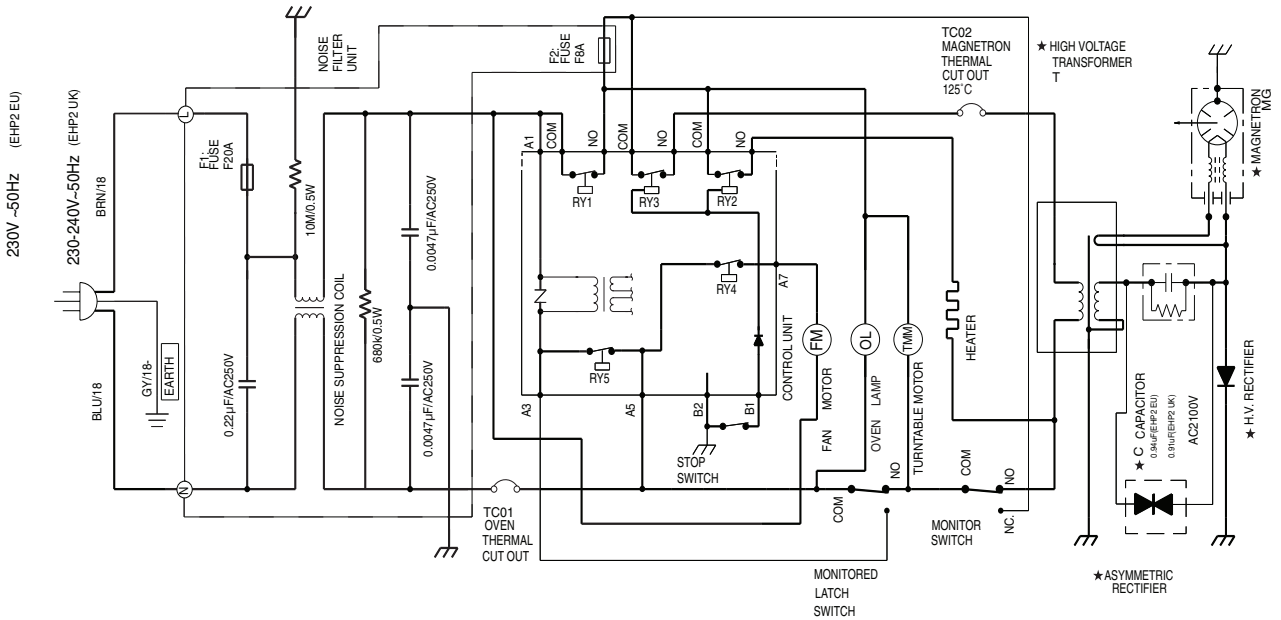


# SCHEMATIC DIAGRAMS



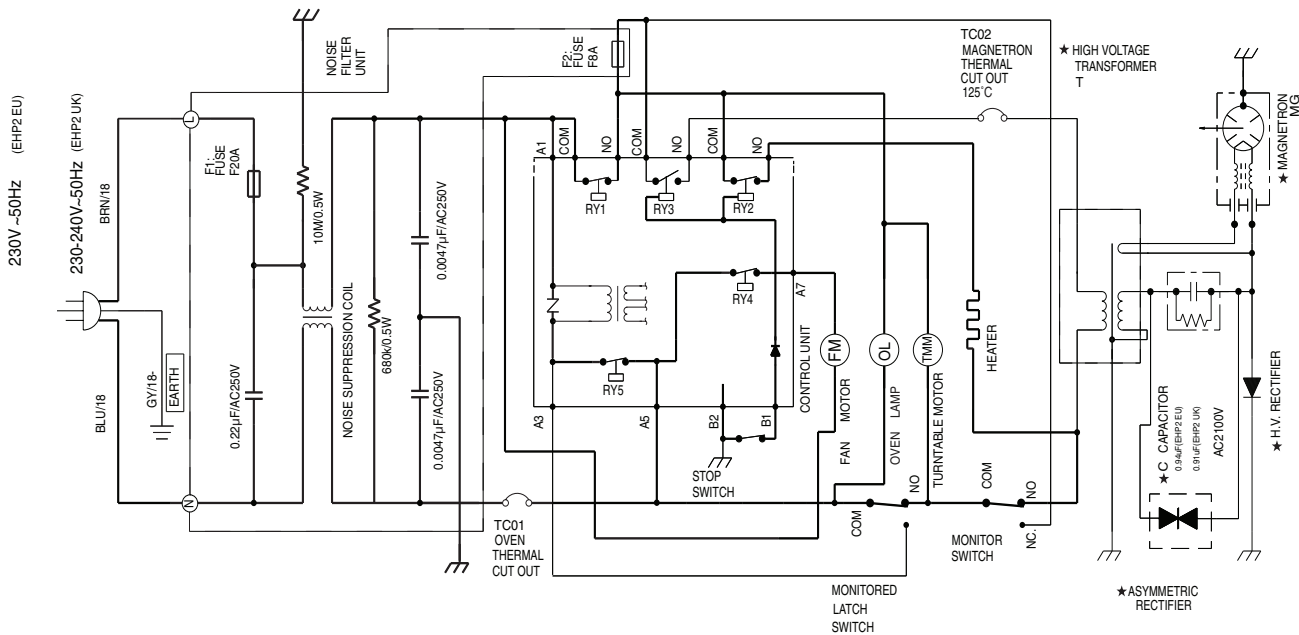
**Figure 0-1 Oven Schematic-OFF Condition, Door Closed.**

\*INDICATES COMPONENTS WITH POTENTIAL ABOVE 250V

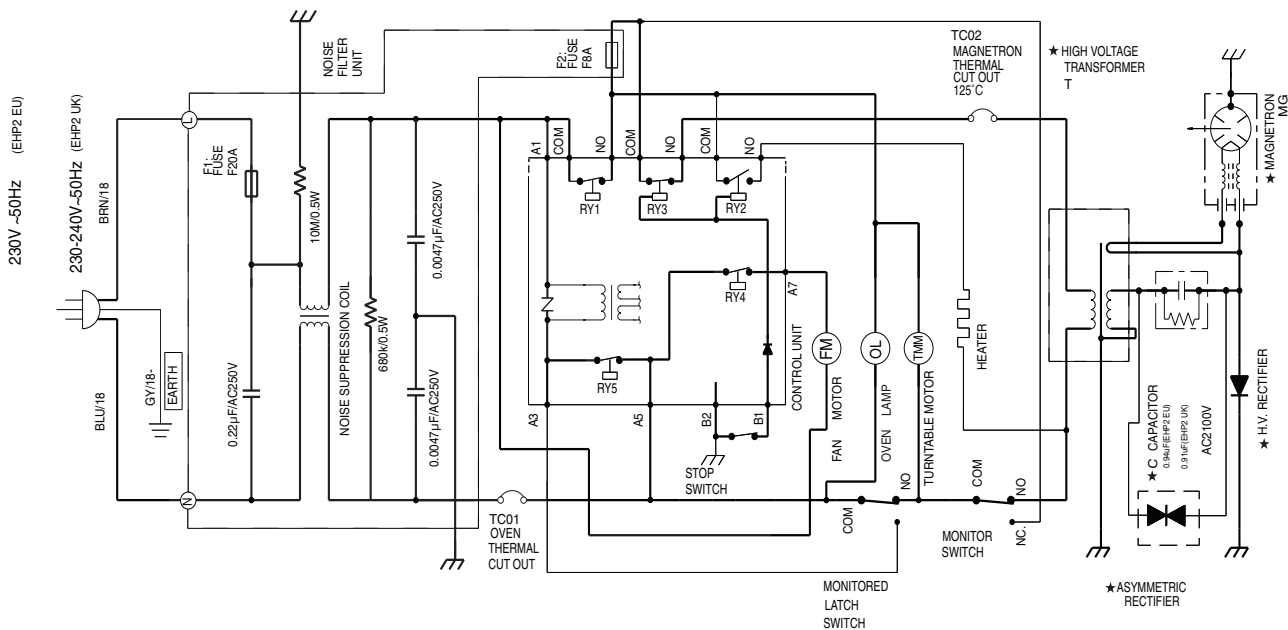


**Figure 0-2 Oven Schematic-ON Dual Cooking Condition, (Microwave and Grill mode).**

# SCHEMATIC DIAGRAMS



**Figure 0-3 Oven Schematic-ON Cooking Condition, (Grill only mode).**



**Figure 0-4 Oven Schematic-ON Cooking Condition, (Microwave only mode).**