

# SCHEMATICS

SCHEMATIC  
NOTE: CONDITION OF OVEN  
1. DOOR CLOSED.  
2. PLUGGED IN OVEN.  
3. NOTHING APPEARS ON DISPLAY.

Note:  
AC CORD CONNECTION  
BRN : BROWN  
BLU : BLUE  
G-Y : GREEN AND YELLOW STRIPE  
/15 : SECTIONAL AREA OF 1.5mm<sup>2</sup> MIN.  
"★" Indicates components with potential above 250 V.

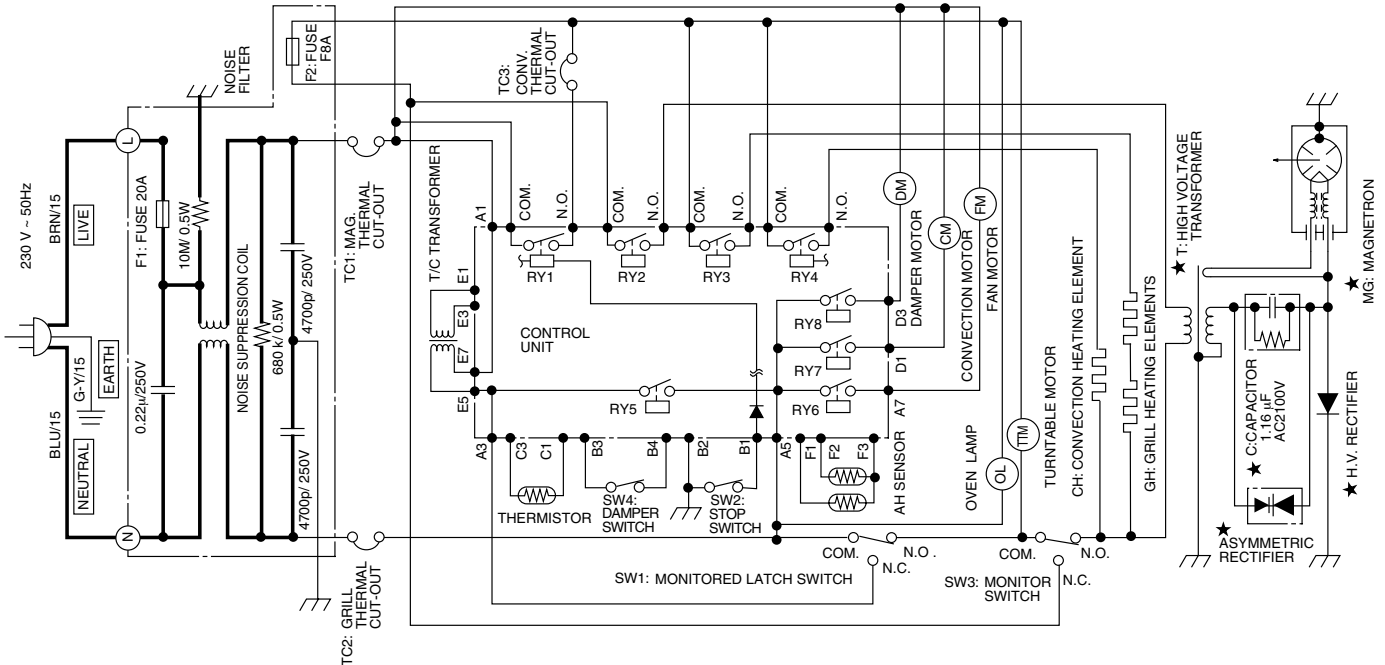

**Oven Schematic-Off Condition right after the oven is plugged in.**

SCHEMATIC  
NOTE: CONDITION OF OVEN  
1. DOOR CLOSED.  
2. "SELECTED LANGUAGE APPEARS ON DISPLAY."

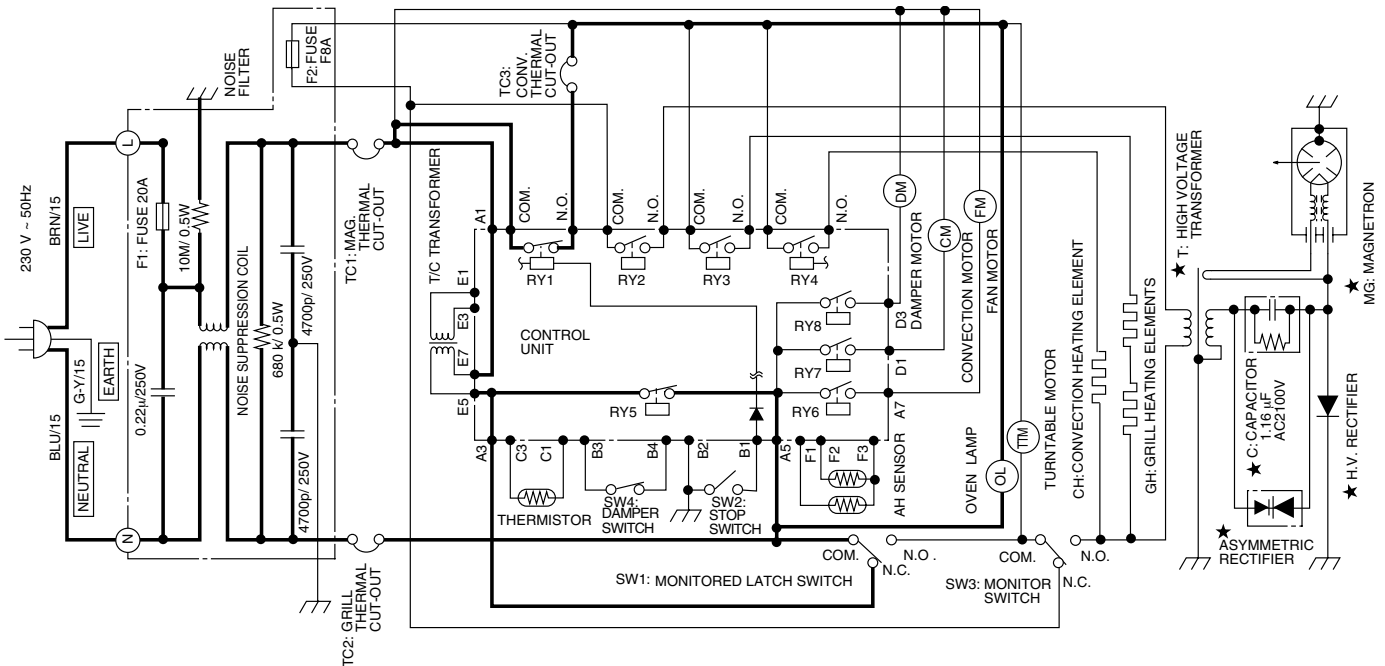

**Oven Schematic-Off Condition when the oven door is opened.**