

ESQUEMA

L-1

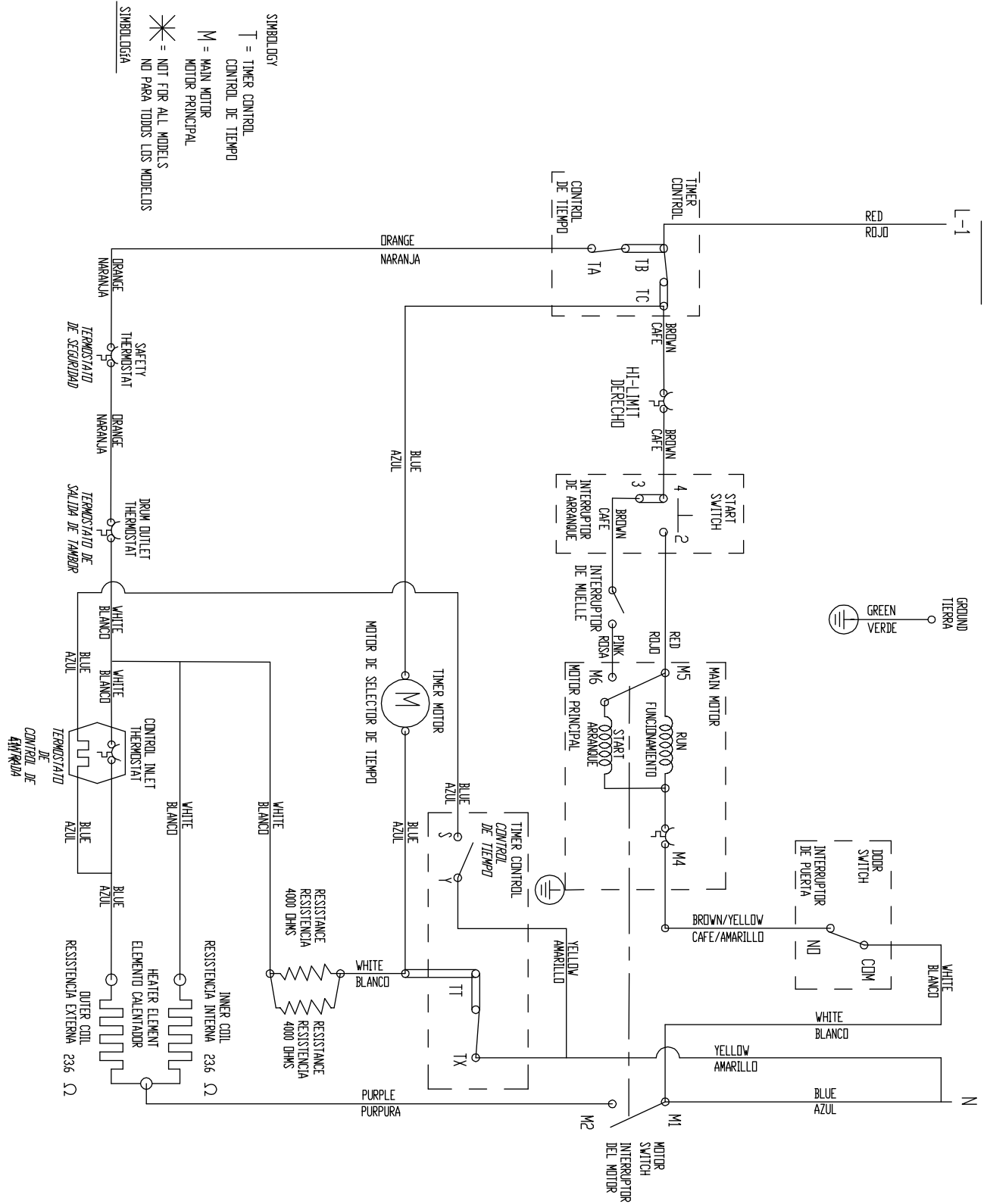

SYMBOLS

- T = TIMER CONTROL CONTROL DE TIEMPO
- M = MAIN MOTOR MOTOR PRINCIPAL
- * = NOT FOR ALL MODELS NO PARA TODOS LOS MODELOS

SYMBOLS