

Anti-interference filter

ON-OFF button

Door safety interlock

Pressure switch

Temperature probe

Motor

Motor overload cut-out

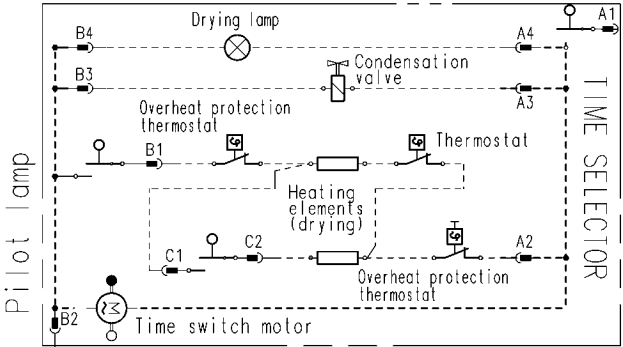

Pilot lamp

Pressure switch

Heating elements (washing)

Drain pump

Fan motor

Cold water inlet valve

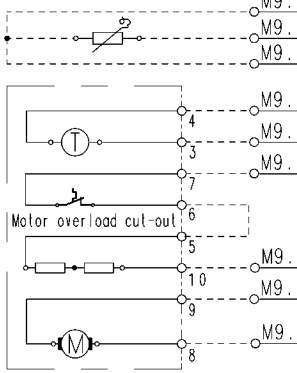

Timer & Electronic module

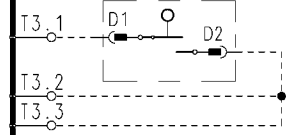
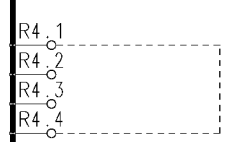

N4.3

N4.1

N4.2

N4.4

G6.4

G6.2

H3.2

H3.1

H3.3

G6.6

L2.2

L2.1

V7.4

V7.3

V7.2

V7.5

V7.6

V7.1

V7.7

G6.3

G6.1

L

N

S5.1

S5.2

S5.3

S5.4

S5.5

P6.1

P6.2

P6.3

P6.4

P6.5

P6.6

Short cycle button

Time selector

Adjustable thermostat