

Ai.f = Anti-interference filter
 b0 = Line switch
 b2 = Door switch
 b7 = Floater switch
 b9 = Salt switch
 b10 = Rinse aid switch
 f3.1 = Overheating protector-
 = (boiling protector)

f3.2 = Overheating thermostat
 f3.3 = Overheating protector
 f5.1 = Level pressostat
 H1 = Heater
 K1 = Start capacitor
 m2 = Main pump

m3 = Drain pump
 Nt = Net terminal
 Ta = Tachometer, inside motor
 Te = Termistor NTC
 S1 = Inlet valve
 S2/4 = Detergent/Rinse aid coil
 S3 = Regeneration valve

= 6.3mm on component
 = 6.3mm electronic
 = PCB
 = Internal connection on electronic- or component
 = Connection with wire

El. circuit diagram MIDI integrated

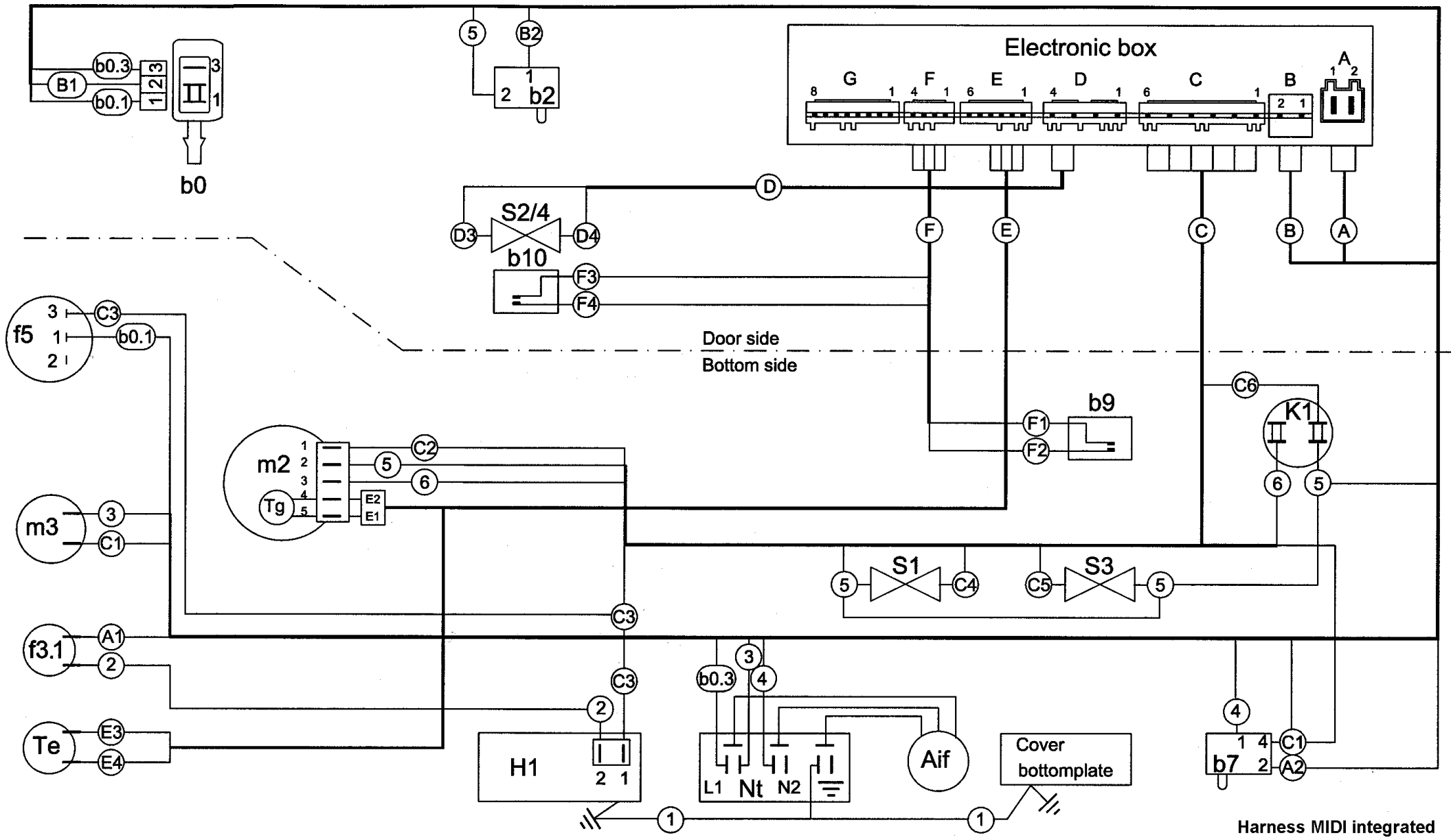

Harness MIDI integrated