

This drawing contains confidential information and is the property of Electrolux. Without whose permission it may not be copied, shown or handed to a third party or otherwise used and it is to be returned promptly upon request to the design owner, who is responsible for the drawing.

Items shown in this drawing must not contain substances that are banned according to Directive, 2002/95/EC, the RoHS Directive (Lead, Cadmium, Mercury, hexavalent Chromium, PBB and PBDE), or substances classified as "Banned" or "Restricted", according to the Electrolux Restricted Materials List.

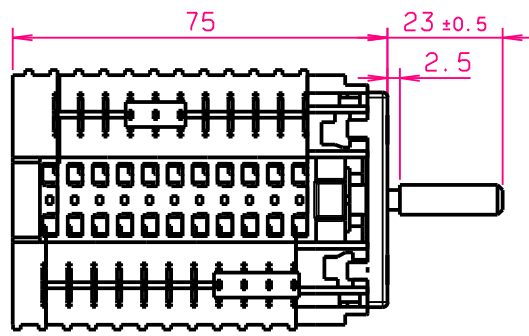

T-marked: T150
 Current/Voltage: 16(6)A/250V
 10(2)A/400V
 Operating torque: Min 20Ncm
 Max 45Ncm
 Type designation: 11HE/133

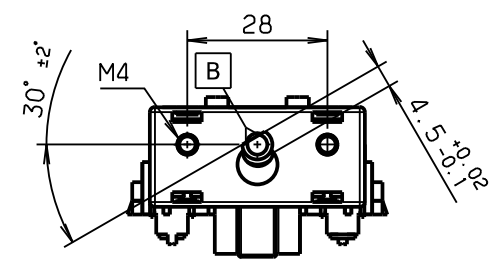
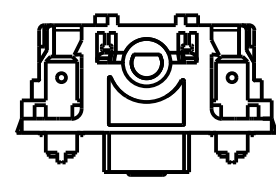

Ⓓ NOTE:
 Detent spring Fe 621

Shaft in 0-position
 Angle deviation Max ±2° for plane
 in relation to c for 2 hole M4

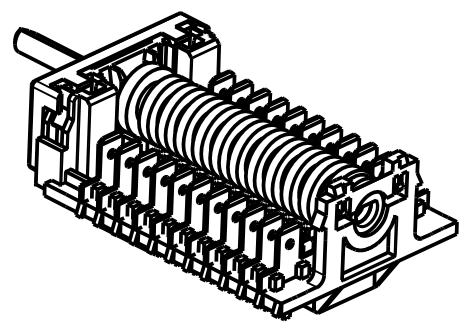
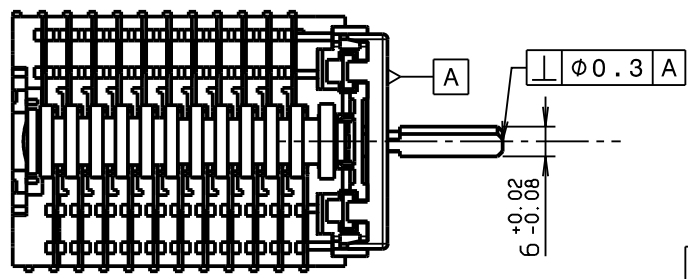

Function	1a	2a	3a	4a	5a	6a	7a	8a	9a	10a	11a	Angle
	Connected to each other											
0 Off	0	0	0	0	0	0	0	0	0	0	0	0
1 Off	0	0	0	0	0	0	0	0	X	X	X	30°
2 Hot Air	X	0	0	0	X	X	X	X	X	X	0	67°
3 Top & Bottom	0	X	0	X	0	X	X	X	X	X	X	104°
4 Pie/Pizza	X	0	0	X	X	X	X	X	X	X	0	141°
5 Browning	0	X	X	0	X	X	X	X	X	X	0	178°
6 Max Grill	0	X	X	0	0	X	X	X	X	X	0	215°
7 Drying	0	0	0	X	X	X	X	X	X	X	X	252°
8 Defrost/Drying	0	0	0	0	X	X	X	0	X	X	X	289°
9 Oven Light	0	0	0	0	0	X	X	0	X	X	X	326°
	1	2	3	4	5	6	7	8	9	10	11	

D Insert NOTE: Detent spring Fe 621				IAN	ABS 5223	2007-04-11
POS.	MODIFICATIONS			SIGNATURE	REQUEST	DATE
MATERIAL	MODEL 3D			SCALE 1:1	EUROPEAN METHOD	
TREATMENT	WEIGHT - Kg.			DESIGN USERS	REPLACES	
DESIGN OWNER	DRM IAN	CHD -	2D ONLY -	DERIVED FROM		
DATE 2006-02-09	APPR -	CONCEPT 3D -	EXACT 3D X	SUPPLY SPECIFICATIONS		
TITLE Oven switch				REV D		
9 pos				SHEET - / -		
Electrolux				NUMBER 349 4661		

349 4661-01	-	-	-	-	-
VARIANT NUMBER	REPLACED NUMBER	POS.	MODEL	DESIGN USERS	CHANGES FROM THE BASE NUMBER