

This drawing contains confidential information and is the property of Electrolux. Without whose permission it may not be copied, shown or handed to a third party or otherwise used and it is to be returned promptly upon request to the design owner, who is responsible for the drawing.

Items shown in this drawing must not contain substances that are banned according to Directive, 2002/95/EC, the RoHS Directive (Lead, Cadmium, Mercury, hexavalent Chromium, PBB and PBDE), or substances classified as "banned" or "Restricted" according to the Electrolux Restricted Materials List.

GENERAL TOLERANCES  
ANGLES  
LENGTHS AND DIAMETERS

Pos. No.

Induction unit  
BC1/BC1

supplier: Stocko  
Part-No.: MFMP 7320-003-000  
Elux-No.:



wire:AWG 24 (0,22 mm2)  
temperature:180 °C, PVC - and halogen free  
length: 180mm  
supplier: Coroplast Li2G SN F21 S9, Typ-No :9-1125

supplier: Stocko  
Part-No.: MFMP 7234-003-000-450  
Elux-No.:

Input rotary

connector  
supplier: Stocko  
Part-No MFMP 7238-004-060-450  
Elux-No 330 6621 02



wire  
AWG 24 (0,22 mm2)  
temperature 180 °C  
PVC - and halogen free  
length : 140 mm  
supplier : Coroplast Li2G SN S9  
Typ-No : 9-1125

connector  
supplier: Stocko  
Part-No MFMP 7238-003-070-450  
Elux-No 330 6621 06

7-segment-rotary

connector  
supplier: Stocko  
Part-No MFMP 7238-004-060-450  
Elux-No 330 6621 02



wire  
AWG 24 (0,22 mm2)  
temperature 180 °C  
PVC - and halogen free  
length : 300 mm  
supplier : Coroplast Li2G SN S9  
Typ-No : 9-1125

connector  
supplier: Stocko  
Part-No MFMP 7238-004-060-450  
Elux-No 330 6621 02

7-segment-Oven UI  
BC1-BI6

connector  
supplier: Stocko  
Part-No MFMP 7238-003-060-450  
Elux-No 330 6621 00



wire  
AWG 24 (0,22 mm2)  
temperature 180 °C  
PVC - and halogen free  
length : 300 mm  
supplier : Coroplast Li2G SN S9  
Typ-No : 9-1125

connector  
supplier: Stocko  
Part-No MFMP 7238-003-060-450  
Elux-No 330 6621 00

Induction unit-OVC2000  
BC1/BC2

connector  
supplier: Stocko  
Part-No MFMP 7234-003-014-450  
Elux-No 330 6617 07



wire  
AWG 24 (0,22 mm2)  
temperature 180 °C  
PVC - and halogen free  
length : 2000 mm  
supplier: Coroplast Li2G SN S9  
Typ-No : 9-1125

connector  
supplier: Stocko  
Part-No MFMP 7234-003-014-450  
Elux-No 330 6617 07

UI/OVC2000  
BI3/BC1

connector  
supplier: Stocko  
Part-No MFMP 7234-004-009-450  
Elux-No 330 661 708



wire  
AWG 24 (0,22 mm2)  
temperature 180 °C  
PVC - and halogen free  
length : 1400 mm  
supplier : Coroplast Li2G SN S9  
Typ-No : 9-1125

4 x cable ties evenly spaced

connector  
supplier: Stocko  
Part-No MFMP 7238-004-060-450  
Elux-No 330 662 102

3 x cable ties evenly spaced

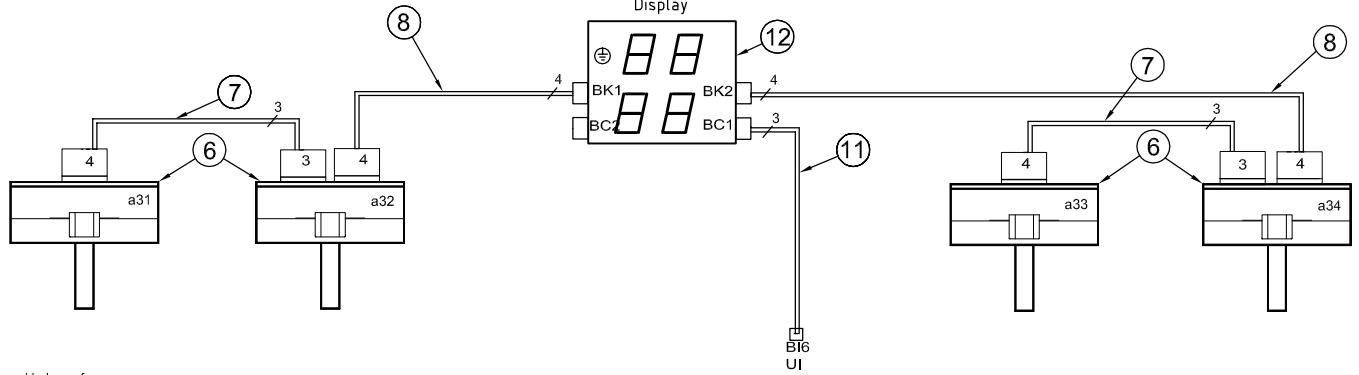

POS	NO	DESCRIPTION
12	1	Display
11	1	Wire set UI-Display 3 pin MACS
10	-	
9		
8	2	Wire set rotary - 7-segment display
7	2	Wire set rotary-rotary
6	4	Input module
5		
4		
3		
2		
1		

COMPONENT LIST

G	Change connector on pos 9	S.Ahl	ABS 3001	2006.03.17
F	Wire pos 5, wire 3 take away	IAN	ABS 2829	2006.02.06
E	Add wire pos 5, change wire length	S.Ahl	ABS 1138	2005.07.19
POS.	MODIFICATIONS	SIGNATURE	REQUEST	DATE
MATERIAL		MODEL	SCALE	EUROPEAN METHOD
TREATMENT		DESIGN USERS	REPLACES	
WEIGHT		DERIVED FROM		
DESIGN OWNER		SUPPLY SPECIFICATIONS		
DRN	S.Ahl	CHD	S.Ahl	2D ONLY
DATE	2004-10-21	APPR	S.Ahl	CONCEPT 3D
				EXACT 3D
TITLE Wiring hob harness				

**Electrolux**

NUMBER 349 4568  
REV G  
SHEET

VARIANT NUMBER	REPLACED NUMBER	POS.	MODEL	DESIGN USERS	CHANGES FROM THE BASE NUMBER
349 4568-04					