

- (M) 230V lamp
- (K) Compressor
- (H) Starting device
- (L) Lamp
- (F) Flexible cord
- (E) Earth cabinet
- (C1) Run capacitor

○ = Sheated cable

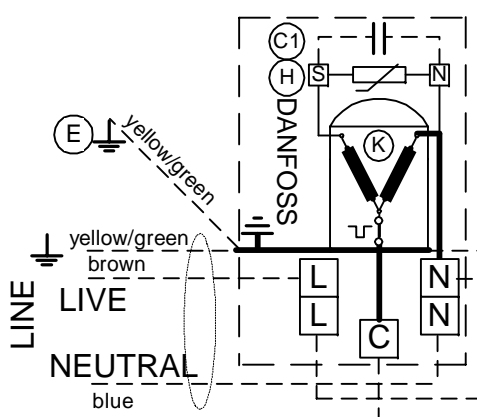
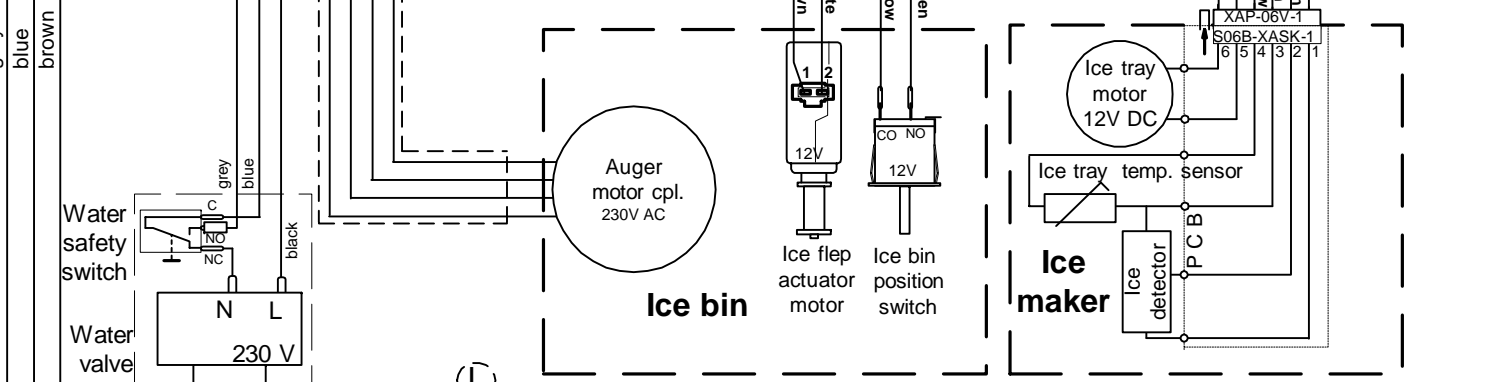
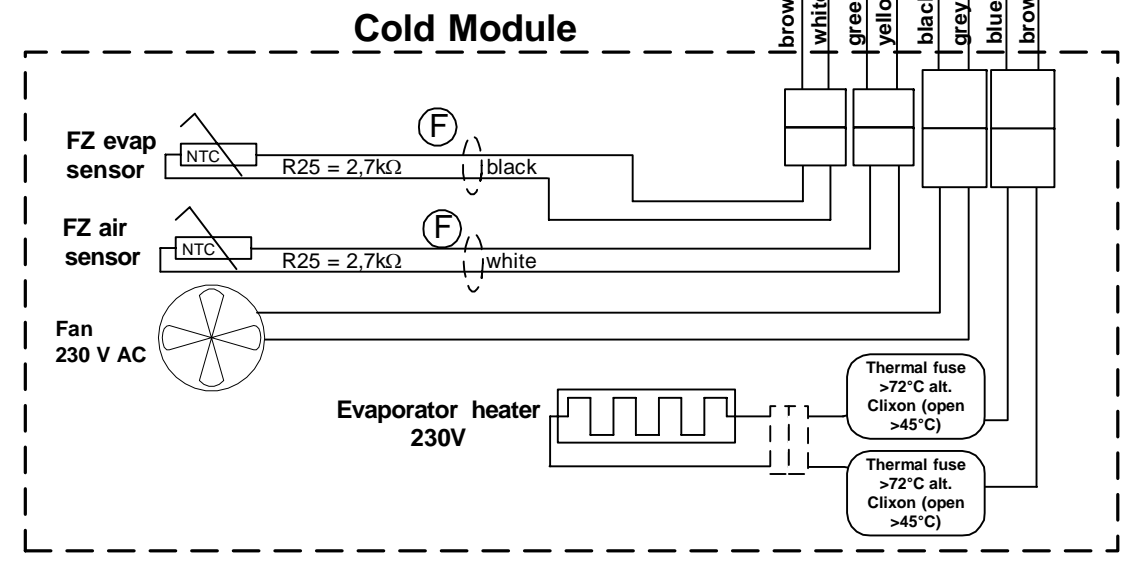
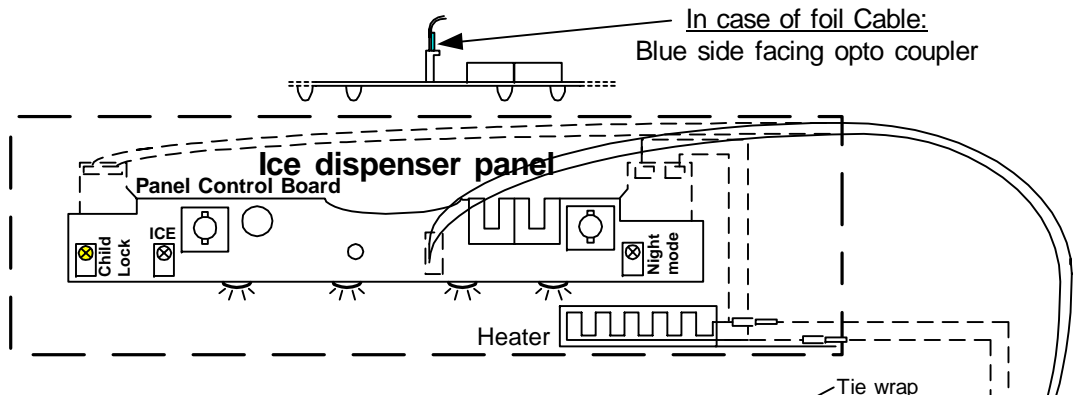
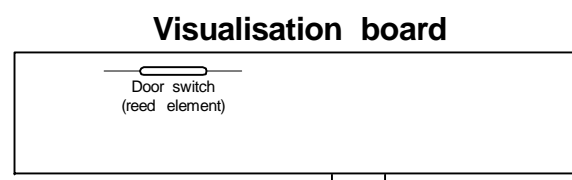
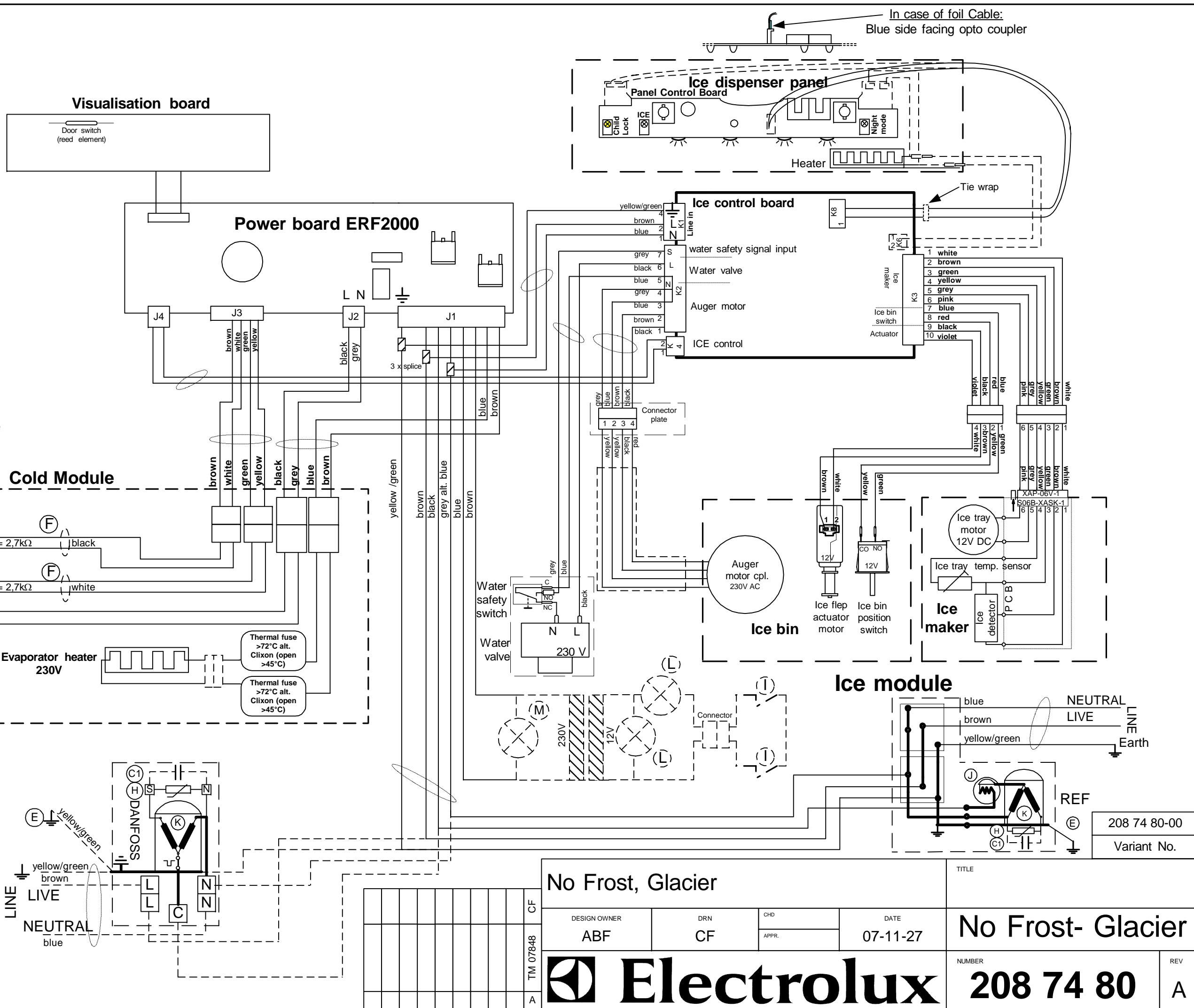

No Frost, Glacier			TITLE	
DESIGN OWNER	DRN	CHD	DATE	
ABF	CF	APPR.	07-11-27	
Electrolux			No Frost- Glacier	
208 74 80			NUMBER	REV
208 74 80			208 74 80	A

208 74 80-00
Variant No.