

- |    |   |    |                        |
|----|---|----|------------------------|
| b2 | Door switch                                   | k2 | RFI capacitor          |
| b3 | Timer contact                                 | m1 | Timer motor            |
| b5 | Temp. selector                                | m2 | Main pump              |
| b7 | Floater switch                                | m3 | Drain pump             |
| b9 | Salt switch                                   | R1 | Heater with protectors |
| f1 | Thermostat 65°C                               | S1 | Inlet valve            |
| f2 | " 55°C  | S3 | Regeneration valve     |
| f3 | Overheating protector-<br>(boiling protector) | S4 | Rinse aid-coil         |
| f5 | Pressure level switch                         |    |                        |
| h2 | Lamp washing                                  |    |                        |
| h4 | Lamp salt                                     |    |                        |
| kp | Terminal block                                |    |                        |
| k1 | Start capacitor                               |    |                        |
- 
- |         |                                |
|---------|--------------------------------|
| ---●--- | Connection 6.6 mm on component |
| —○—     | Connection 6.3 mm on timer     |
| —       | Internal connection on timer   |
| ----    | Connection with wire           |

El. circuit diagram.  
1503989

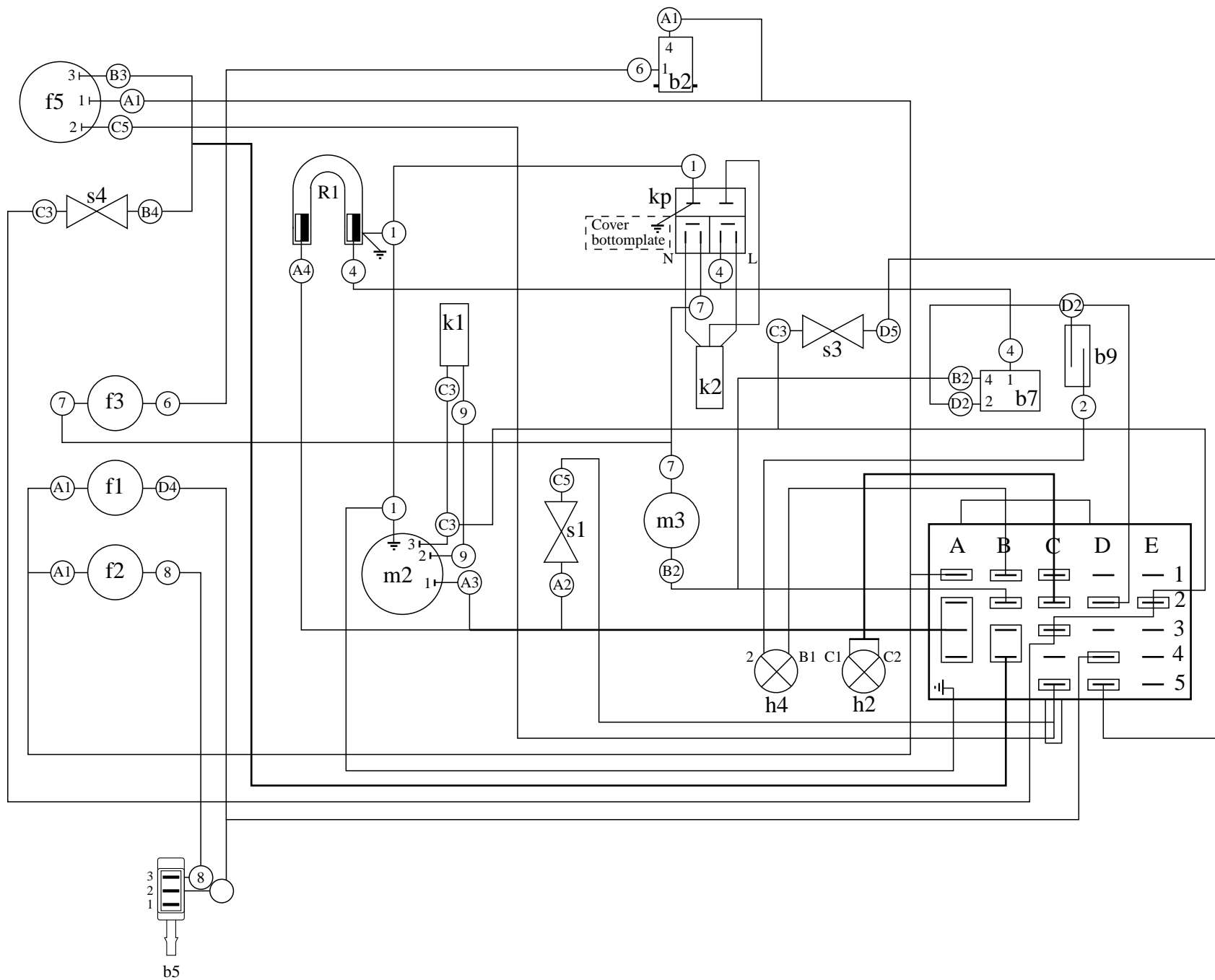

9	White	150 33 27-01
8	Grey	150 42 48-06
7	Blue	150 37 08-24
6	Red/white	150 37 09-19
4	Black	150 37 08-23
1	Yellow/green	150 29 74-05
D5	Violet	150 37 09-12
D4	Black	150 37 08-06
D2	Orange	150 37 08-25
C5	Pink	150 37 08-20
C3	Brown	150 33 64-07
B4	Violet	150 39 93-00
B2	White	150 37 08-19
B1	Orange	150 39 97-00
2	Orange	150 39 96-00
C2	Red	150 39 96-00
C1	Red	
A4	Grey	150 39 85-00
A3	Orange	
A2	Pink	
A1	Brown/white	150 33 28-14
Don	Colour	Kabel no.

**HARNISS**  
150 39 90