

This drawing contains confidential information and is the property of Electrolux, without whose permission it may not be copied, shown or handed to a third party or otherwise used and it is to be returned promptly upon request to the design owner, who is responsible for the drawing.

Items shown in this drawing must not contain substances that are banned according to Directive, 2002/95/EC, the RoHS Directive (Lead, Cadmium, Mercury, hexavalent Chromium, PBB and PBDE), or substances classified as "Banned" or "Restricted" according to the Electrolux Restricted Materials List.

### Einzellitzen / single wires

Pos	Kontaktfolge / contact	Auflösung / structure explanation	min Ø	colour	no
1	x50/L1/Platine - X1/1 - x50/L1/Platine	175 - 420 - 175 - 420 - 175	1,5 - 1,0	or	h131
2	X1/2 - x51/L2/Platine	175 - 500 - 175	1,5	gr	h70
3	x52/N1/Platine - X1/4 - x52/N1/Platine	175 - 460 - 175 - 460 - 175	1,0 - 1,0	bl - bl	h122
4	x53/N2/Platine - X1/4 - x53/N2/Platine	175 - 460 - 175 - 460 - 175	1,0 - 1,0	bl - bl	h122
5	X1/PE - x54/PE/Platine - PE/Blech	175 - 500 - 196 - 220 - 158	1,5 - 0,75	gng - bl	h115
6	X1/PE - PE/Mulde	175 - 250 - 182	1,5	gng	h64
7	x66/Platine - r32/2	175 - 340 - 194	0,75	ws	h101
8	x66/Platine - r33/2	175 - 620 - 194	0,75	sw	h26
9	x62/Platine - r33/4	175 - 600 - 194	0,75	gn	h73
10	x63/Platine - r32/4	175 - 340 - 194	0,75	ws	h101
11	x64/Platine - r33/4a	175 - 520 - 194	0,75	vio	h28

<b>Steuerleitung / control line</b>		(separate Lieferung)
Kontaktfolge / contact	Sachnummer / article number code	
filter board (X67) - user interface	330 637 402	

### Ansicht von oben!

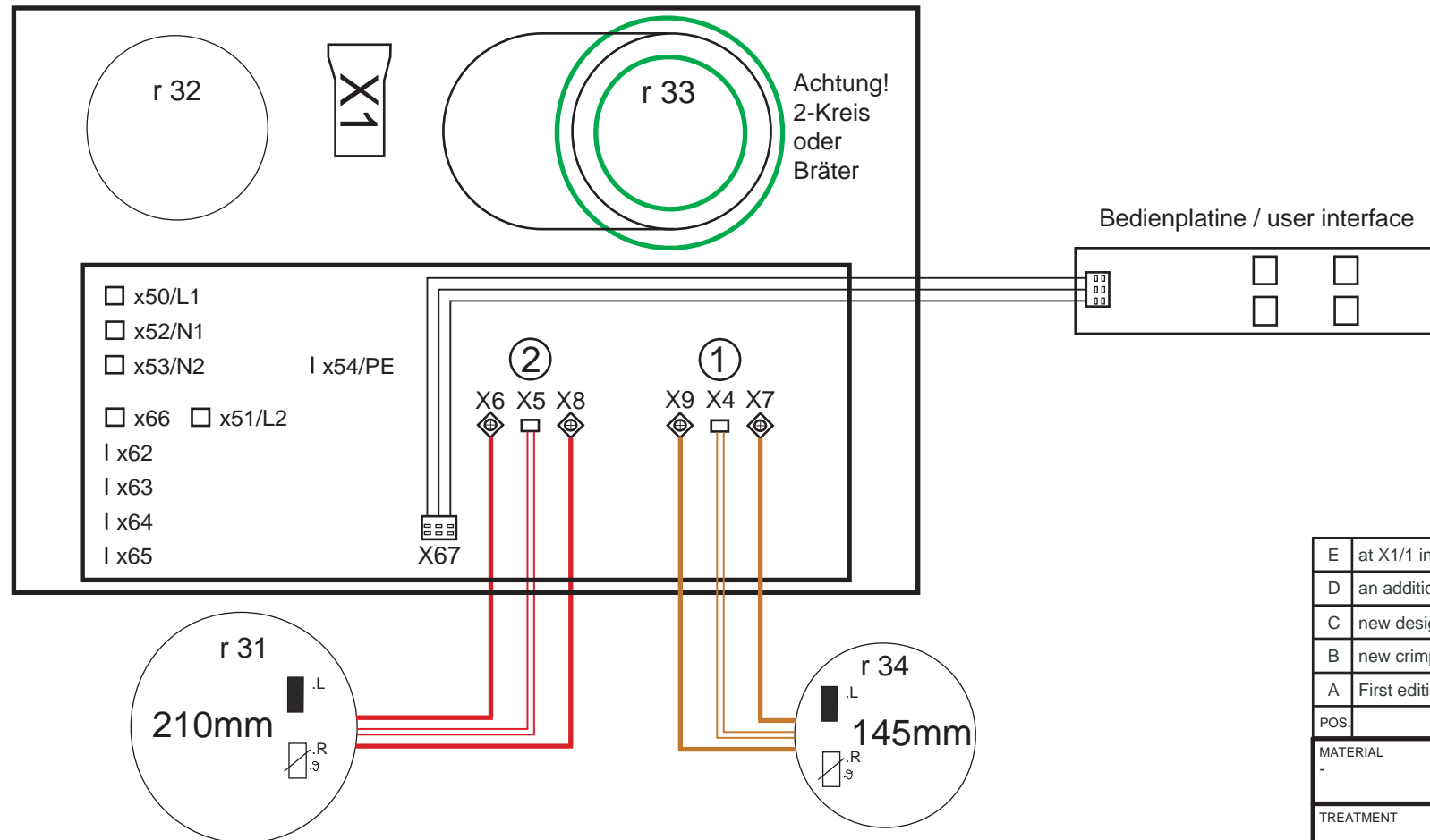

Bezeichnung	designation	Elux Sachnummer	Elux part no
Liste Anschlagteile	list of crimp contacts	330 1766 00	
Betriebsmittelliste	list of components	330 2222 00	
Liste Einzellitzen	list of single wires	330 5347 00	
Anschlußbezeichnungen	Port identification	330 6406 00	
Leitungsmaterial	wire material	330 5273 00 / 330 5274 00	

E	at X1/1 instead of 2x h13 now the new wire figure h131	Weiß	DGT36751	2005-11-24
D	an additional wire (orange) at X1/1 and two new wires (blue) with double crimp at X1/4	Weiß	DGT26761	2004-10-26
C	new designations and new crimping contact at pos. 5 (instead of 175 now 158)	Weiß	DGT23914	2004-08-27
B	new crimping contact at pos. 5 (instead of 182 now 175)	Weiß	DGT23556	2004-06-08
A	First edition	Weiß	DGT22713	2004-04-14

MATERIAL		MODEL		SCALE		EUROPEAN METHOD	
TREATMENT		WEIGHT		DESIGN USERS		REPLACES	
DESIGN OWNER		DATE		SIGNATURE		REQUEST	
DGT		2004-04-14		DATE		DATE	
pd_hot kitchen high		2004-04-14		TITLE		wiring hob cpl.	
CHD Weiß		2004-04-14		Verdrahtung Mulde kpl.		REV	
2D ONLY		2004-04-14		NUMBER		330 7056	
CONCEPT 3D		2004-04-14		REV		E	
EXACT 3D		2004-04-14		1/1			

GENERAL TOLERANCES  
ANGLES  
LENGTHS AND DIAMETERS

330 7056 00			wiring hob cpl., independent G4 (mixed-hob 60 cm / 2xinduction 1x2 1x1 circle)
VARIANT NUMBER	REPLACED NUMBER	POS.	CHANGES FROM THE BASE NUMBER