

m1	motor
g1	tacho
m22	rec. pump
h10	door locked lamp
s15	bl_hot
s2	wash
s1	pre wash
fS	safety pressure switch
fN	pressure switch
fTR	level for dry protection
f16.	floating switch
m3	drain pump

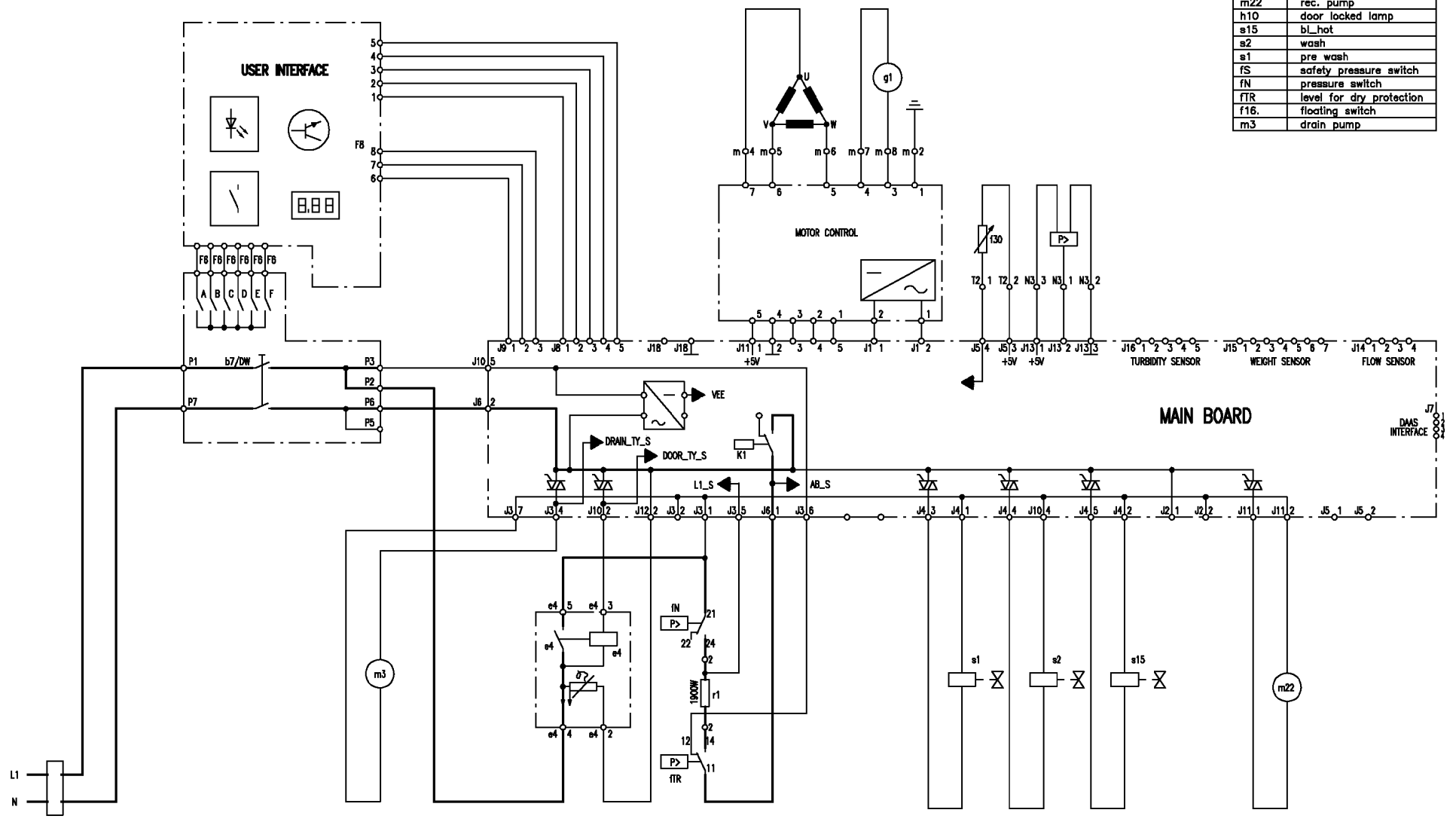

L1  
N