

m1	motor
g1	tacho
m22	rec. pump
h10	door locked lamp
s15	bl_hot
s2	wash
s1	pre wash
fS	safety pressure switch
fN	pressure switch
fTR	level for dry protection
f16.	floating switch
m3	drain pump

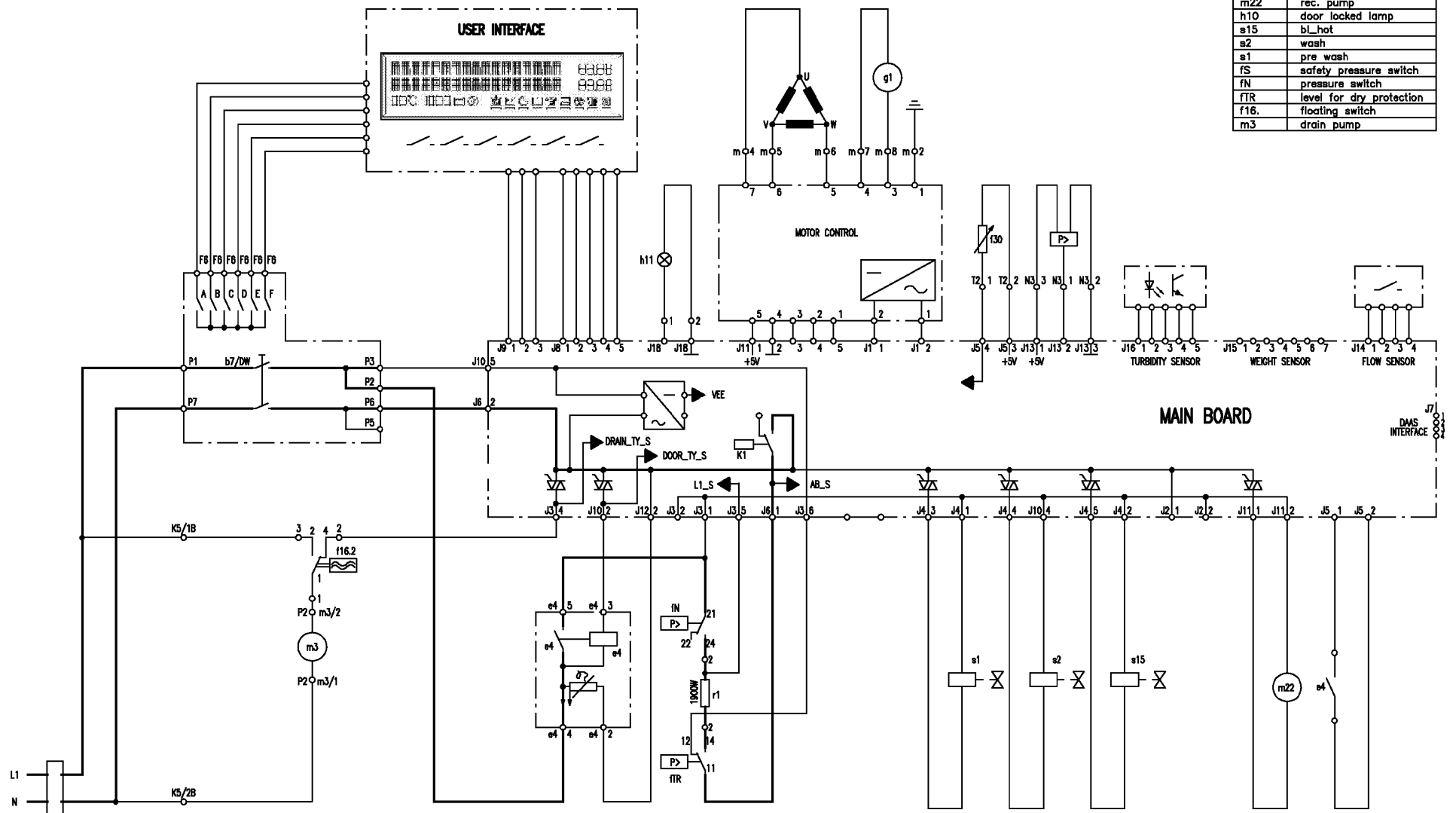

MAIN BOARD

USER INTERFACE

MOTOR CONTROL

DAS
INTERFACE